



# DOORS BOISERIE

ALUMINIUM CHIC COLLECTION

TRUE LUXURY  
IS THE PLEASURE  
OF CHOICE.

# ABSOLUTE *quality*



Grande tradizione artigianale, utilizzo di materiali nobili e pregiati, ricerca costante in continua evoluzione: sono questi i valori che da sempre contraddistinguono le creazioni Longhi. L'attenzione al dettaglio si coniuga con l'uso di materiali esclusivi: le essenze lignee lavorate affidandosi all'abilità e alla cultura di operatori altamente preparati, i marmi e le pietre provvisti di certificati d'Autenticità e Garanzia insieme alle pelli, accuratamente selezionate e lavorate con procedimenti naturali rispettando l'ambiente, armonizzano semplicemente passione ed eleganza.

*An outstanding tradition of craftsmanship, the use of precious materials, and on-going research to ensure continuous evolution: these values always stand out in a creation by Longhi. Attention to detail works in concert with the use of exclusive materials: woodworking is entrusted to the skill and expertise of highly trained craftsmen. All marbles and stone have Certificates of Authenticity and Guarantees, as do our leathers - which are specifically selected and processed with natural environmentally friendly procedures. All these materials harmonise simply to convey passion and elegance.*

Многолетние ремесленные традиции, применение благородных и ценных материалов, непрерывные и постоянно развивающиеся исследования: именно эти ценности всегда отличали творения Longhi. Внимание к деталям сочетается с использованием эксклюзивных материалов: древесные породы, обработанные искусными и высококвалифицированными работниками, мрамор и камень, имеющие сертификаты подлинности и гарантийные сертификаты, и кожа, тщательно отобранная и обработанная натуральными методами, не причиняющими вреда окружающей среде, создают гармонию увлеченности и элегантности.

优秀的传统手工艺、采用贵重材料、不懈研究并持续发展，这些正是使Longhi作品始终非凡的价值。注重细节加上使用独特材料：精华木质的加工，就交付给受过高度训练大师的技能与专长。所有大理石与石材皆具备真品证书和质保书，而皮革，同样经过精选并采用注重环保的天然程序进行处理，简单地将激情与优雅融入其中。





# MADE *in* ITALY



Il Made In Italy è la caratteristica che contraddistingue ogni aspetto dell'attività e della produzione Longhi. Ogni processo di lavorazione ha un'elevatissima componente manuale, consentendo un accurato controllo di ogni minimo dettaglio. La produzione, totalmente interna, utilizza solo materie prime di origine italiana ed è altamente customizzata in quanto tiene conto delle particolari esigenze del cliente.

*"Made in Italy" represents the characteristic that permeates every aspect of Longhi's business and production. Every production process is largely manual, which allows for precision and control of each detail. We only use raw materials of Italian origin, and our in-house production process is highly customised in order to accommodate particular needs specified by clients.*

*Made In Italy - это характеристика, отличающая все аспекты деятельности и производства Longhi. Каждый процесс обработки содержит высокую долю ручной работы, что обеспечивает тщательный контроль даже самых мельчайших деталей. Производство, в котором используется только итальянское сырье, осуществляется полностью на внутреннем уровне и обладает высокой степенью персонализации благодаря учету особых требований заказчиков.*

意大利制造是Longhi制品与各种业务的主要特质。手工组件在每个加工流程中都占极高的比例，因此允许了对每处微小细节进行细心控管。生产，完全由内部执行，并仅采用意大利原产的原料制造。此外也具有高度可客制化特性，因为我们重视客户的独特需求。

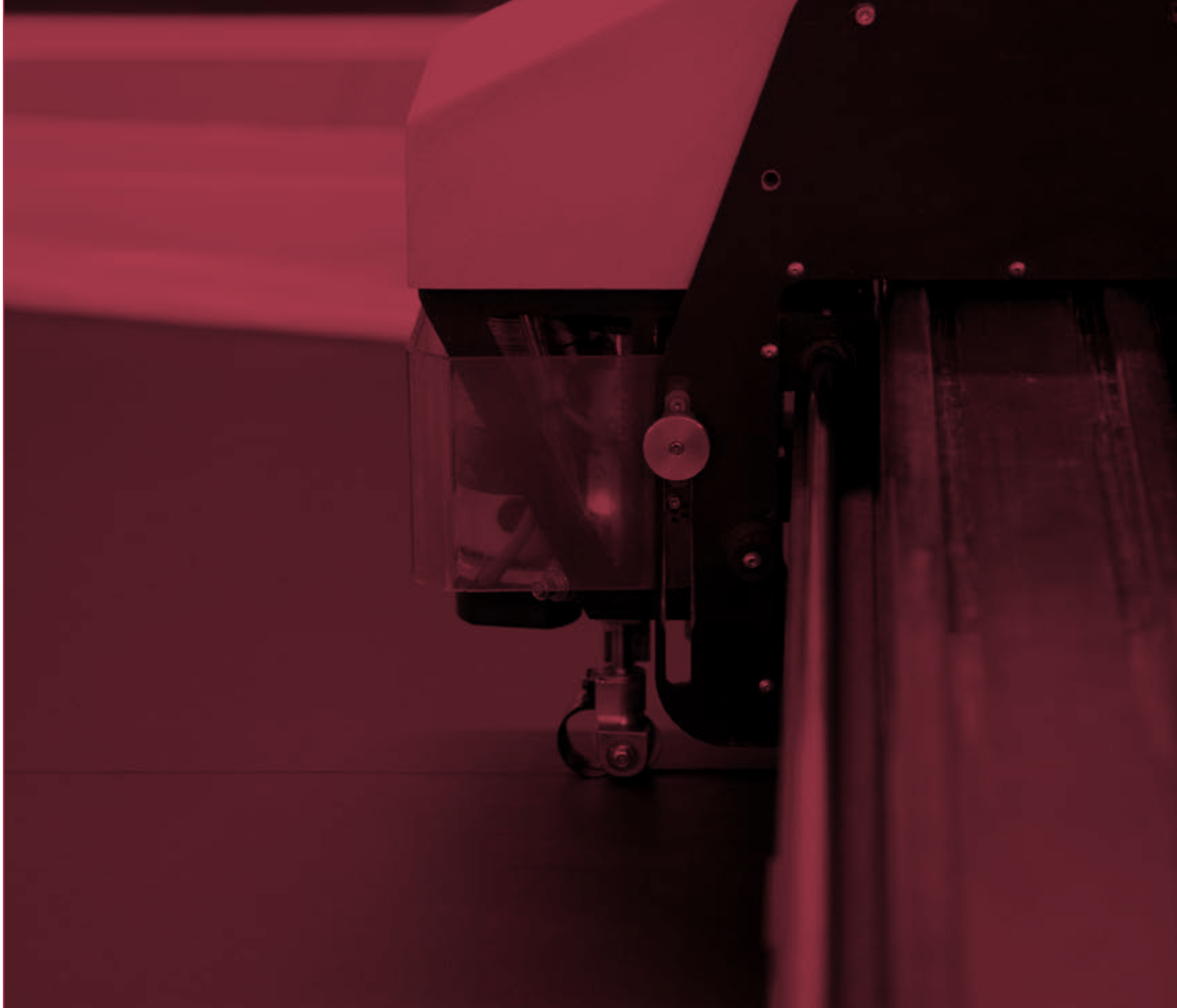

INIMITABLE PIECE,  
100% MADE IN ITALY.

# MADE *for you*



Ogni pezzo è fatto a mano, spesso su misura, e sottoposto a controlli per offrire il massimo della qualità, conferendogli un valore unico, esclusivo e dalle caratteristiche eccellenti totalmente Made in Italy. Personalizza il tuo divano, scegli i tuoi colori preferiti, realizza la misura che meglio si adatta al tuo arredamento e firmalo; noi lo realizzeremo esclusivamente per te in edizione limitata ad un solo esemplare: il tuo.

*Each piece is hand made, and often also made-to-measure. Moreover, each item undergoes inspections to ensure the highest quality standard and give it unique and exclusive value, enhancing its exceptional features: completely Made in Italy. Customize your sofa, choose your favourite colours, figure out the best size to fit with your furnishings, and put your signature on it. We will make it just for you, in a limited edition one piece only: yours.*

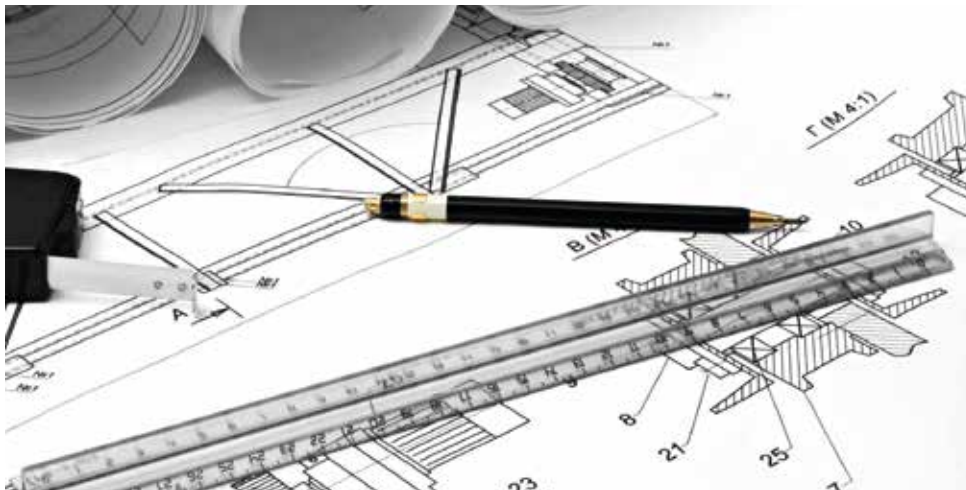

Каждое изделие изготавливается вручную, часто на заказ, и подвергается контролю для обеспечения максимального качества, что придает ему уникальную, эксклюзивную ценность с превосходными характеристиками полностью Made in Italy. Придайте своему дивану индивидуальность, выберите свои любимые цвета, определите размер, наилучшим образом подходящий к вашему интерьеру, и направьте запрос нам. Мы изготовим его эксклюзивно для вас в единственном экземпляре - вашем.

每件作品皆由手工制作，通常是量身定制的作品；所有品项皆经过严格控管，旨在提供最高质量，并赋予每件产品专属与独特的价值，以及完全意大利制造的卓越特性。客制化你专属的沙发，选择你偏爱的颜色，以最适合你装潢的尺寸制作并签名：我们将特别为你制作这独一无二的限量版款式：你的款式。





# TAILOR *made*



Nata dalla lavorazione di preziose mani artigiane, la collezione Loveluxe rispecchia quel gusto elegante e raffinato dove la creatività dei designers si fonde con la naturalezza delle materie prime utilizzate, lavorate manualmente con la cura per ogni dettaglio, così da trasformare la materia in un oggetto unico ed inimitabile, prodotto al 100% in Italia. Ogni anno maturano concetti e tendenze distinte dove stile e senso estetico si uniscono alla collezione Loveluxe.

*A tradition of precious craftsmanship is behind the Loveluxe collection, which displays the elegant and refined taste generated when a designer's creativity merges with the natural features of the raw materials. Skilfully handworked with attention to detail, the simple materials are transformed into unique pieces that are 100% made in Italy. Every year new concepts and trends develop, bringing style and aesthetic excellence into the Loveluxe collection.*

*Созданная умелыми руками мастеров-ремесленников, коллекция Loveluxe отражает элегантный и изысканный вкус, в котором творчество дизайнеров сливается с натуральностью используемого сырья. Обработанные вручную с внимательным отношением к каждой детали, эти материалы становятся уникальным, неподражаемым изделием, на 100% произведенным в Италии. С каждым годом возникают новые концепции и тенденции, где особый стиль и эстетическое чувство объединяются с коллекцией Loveluxe.*

出自精湛手工艺大师之手，Loveluxe系列反映出优雅与精致的品味，于其中，设计师的创意与所使用的原料自然融合。以手工制作并结合呵护与细节关注所加工的珍贵材料，也因此得以转变成独特、无可仿制、100%于意大利制造的精品。概念和不同趋势每年增长成熟，其中风格与美感完全地结合在Loveluxe系列之中。



A photograph of a modern interior space, possibly a living or dining area, with a strong red color overlay. The scene is divided by a central glass partition. In the background, there's a dining table with chairs and a sofa. The lighting is dramatic, with some starburst effects from ceiling lights. The overall aesthetic is contemporary and sophisticated.

COORDINATED  
LIVING IN THE NAME  
OF A UNIQUE AND  
DISTINCTIVE DESIGN  
LANGUAGE.

# company SHOWROOM



Sorge all'interno del complesso industriale di Meda, sede dell'azienda. Una superficie di ben 1200 mq distribuiti su due piani ampi e luminosi. Uno spazio in continua evoluzione destinato a ospitare le collezioni più recenti per offrire al visitatore originalità e ampia scelta. Al piano terra vengono collocati porte e piccoli complementi d'arredo; mentre il primo piano è completamente e interamente di gusto Loveluxe, collezione di punta dell'azienda che opera nel mondo del "Luxury Living".

*Our showroom is located within the industrial facility in Meda, at the company's headquarters. Set on two spacious and bright floors, a continuously updated 1200 square meter space is aimed to display the most recent collections and offer the visitor a wide and original selection. On the ground floor, doors and small pieces of furniture are on display, while the first floor is entirely devoted to the Loveluxe mood, a flagship collection for the company operating on the "Luxury Living" scene.*



Головной офис компании расположен в промышленном комплексе города Меды и занимает два просторных и светлых этажа общей площадью 1200 квадратных метров. Постоянно изменяющееся пространство предназначено для демонстрации самых последних коллекций Longhi и предоставления заказчикам оригинального и большого выбора. На первом этаже представлены двери и небольшие мебельные аксессуары, а второй этаж полностью посвящен Loveluxe, главной коллекции компании, работающей в секторе «Luxury Living».



它位于梅达 (Meda) 工业园区, 该公司的总部所在地。一个位于宽敞明亮的两层楼, 面积约 1200 平方米的区域。一个不断更新的空间, 旨在展示最新的设计集, 并向访客提供一个广泛的和独创的选择。地面层容纳了门和小件家具, 而楼上层完全是 Loveluxe 品位, 这家运营在“奢华生活”世界的公司的一个旗舰设计集。



# TOTAL *home* DESIGN



Lo studio degli interni è da sempre un campo di sperimentazione e ricerca. Longhi è un'azienda legata ai temi dell'abitare contemporaneo, attenta all'evoluzione del gusto ma con solide radici nella realtà produttiva. La varietà dei temi affrontati è il risultato di un progetto d'impresa globale e coerente che investe ogni aspetto del processo produttivo. Dallo sviluppo dei prototipi, alle tecnologie applicate, al servizio clienti, alla comunicazione fino alla scelta dei materiali.

*Interior design has always been a field of experimentation and research. Longhi is a company whose core focus is contemporary living. While mindful of changes in taste, its manufacturing roots run deep. The variety of items it offers is the result of a consistent global, corporate strategy that influences every aspect of the production process from prototypes development, to applied technologies, to customer service and communication till choice of material.*

*Дизайн интерьера - это область, для которой характерно экспериментирование и поиски. Longhi - это компания, специализирующаяся на современном интерьере, которая внимательно следит за развитием вкуса, опираясь при этом на многолетние производственные традиции. Разнообразие продукции является результатом комплексного и последовательного подхода к производству, который характеризует все этапы производственного процесса: от разработки прототипов до применяемых технологий, сервисного обслуживания покупателей, коммуникации и выбора материалов.*

室内设计始终是一个实验与研发的领域。Longhi是一间与当代居住主题有密切关联的企业，在注重品味演化的同时，也重视现实生产的稳固根基。涉及的各种主题是一间全球性企业项目的成果，并与投资在生产流程的各处环节一致。从开发到原型制品，从所运用的科技到客户服务，从沟通到选择物料。

# ALUMINIUM CHIC COLLECTION

# DOORS PORTE



LAND  
pg 16



IANUS  
pg 70



FOREVER  
pg 176



BEMINE  
pg 224



SPARK  
pg 248

# LAND

designed by Alessandro La Spada | 341

Land è un sistema costituito da moduli scorrevoli, porte battenti e boiserie abbinati a elementi di servizio che creano la possibilità di articolarsi nello spazio unendo distinto gusto e efficace funzionalità. Una vera e propria architettura domestica fatta da una progettazione su misura grazie a una ricerca minuziosa e capillare. Infinite possibilità compositive, tecnologie innovative tra accessori e luci, originali rivestimenti come per esempio la carta da sughero impreziosita da piccole schegge d'oro.

*Land is a system of sliding modules, hinged doors and boiserie panels matched with accessories that create the possibility of development in space by combining distinct taste and effective functionality. This is an authentic domestic architecture made up of made-to-measure design based on careful and thorough research. Infinite composition options, innovative technologies that include accessories and lighting, original coverings - such as paper made from cork embellished with tiny golden flakes.*

*Land - это система, состоящая из раздвижных модулей, распашных дверей и панелей буазери, которые сочетаются со вспомогательными элементами и создают возможность развития в пространстве, объединяя изысканный вкус и эффективную функциональность. Это настоящая домашняя архитектура, представляющая собой проект «на заказ» благодаря тщательным и детальным исследованиям. Бесконечные композиционные возможности, инновационные технологии для аксессуаров и светильников, оригинальные покрытия, такие как бумага из коры пробкового дуба, украшенная мелкой золотой крошкой.*

Land系统由推拉滑动模块、平开门与护壁板搭配服务性元素所组成，通过结合独特品味与有效的功能性，创造规划空间的各种可能。是一种真正以量身定制项目特制的居家建筑结构，是经过细致与深入研究的成果。无限的组合可能性，配件与照明间的创新科技，原创的面饰，例如，添加小金片的软木纸。







SLIDING PANELS | LAND  
STRUCTURE | MATT SATINED BRONZE  
PANELS | P.3 TECSUEDE 5604  
HANDLE INSERT | ROSSO LEVANTO MARBLE

# TECHNICAL NOTES

## *Sliding door*

---

### DOOR SECTION



---

### DESIGN OPTIONS

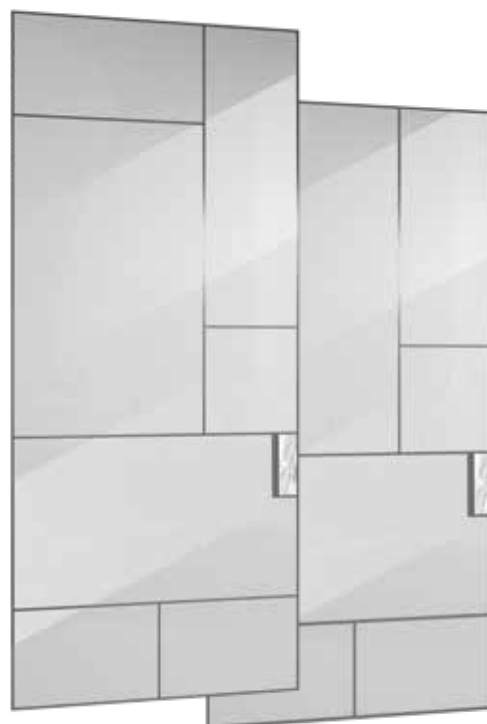

---

SLIDING DOOR WITH RAIL



WALL SLIDING



CEILING SLIDING



CEILING BUILT-IN SLIDING

---

POCKET SINGLE DOOR



TRIPLE JAMB



FREE JAMB

---

POCKET DOUBLE DOOR



TRIPLE JAMB



FREE JAMB

# TECHNICAL NOTES

## *sliding systems*

TRAVI DI SCORRIMENTO A SOFFITTO CON MASCHERINA 1 VIA  
*One way ceiling sliding rails with visible closing cover*



TRAVI DI SCORRIMENTO AD INCASSO A SOFFITTO A 1 VIA  
*One way ceiling built-in sliding rails*

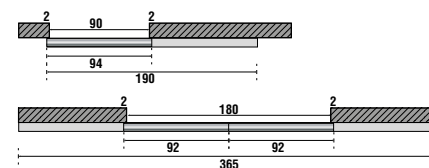

TRAVI DI SCORRIMENTO A SOFFITTO CON MASCHERINA 2 VIE  
*Two way ceiling sliding rails with visible closing cover*



TRAVI DI SCORRIMENTO AD INCASSO A SOFFITTO A 2 VIE  
*Two way ceiling built-in sliding rails*

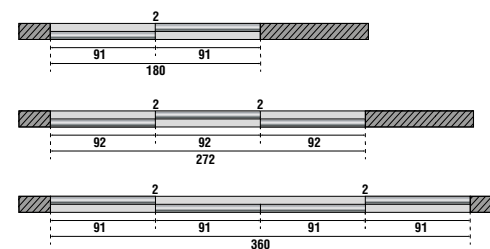

TRAVI DI SCORRIMENTO A SOFFITTO CON MASCHERINA 3 VIE  
*Three way ceiling sliding rails with visible closing cover*



TRAVI DI SCORRIMENTO AD INCASSO A SOFFITTO A 3 VIE  
*Three way ceiling built-in sliding rails*

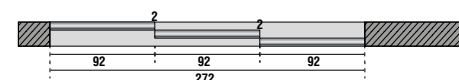

TRAVI DI SCORRIMENTO A PARETE CON MASCHERINA 1 VIA  
*One way wall sliding rails with visible closing cover*



TRAVI DI SCORRIMENTO A PARETE AD INCASSO 1 VIA  
*One way wall built-in sliding rails*

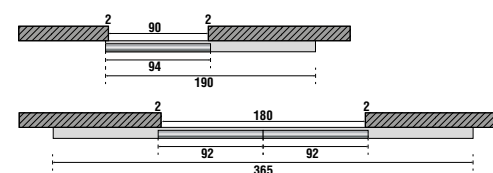

TRAVI DI SCORRIMENTO A PARETE CON MASCHERINA 2 VIE  
*Two way wall sliding rails with visible closing cover*



TRAVI DI SCORRIMENTO A PARETE AD INCASSO 2 VIE  
*Two way wall built-in sliding rails*

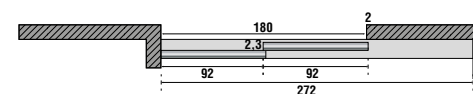

## *Soft opening / Soft close*

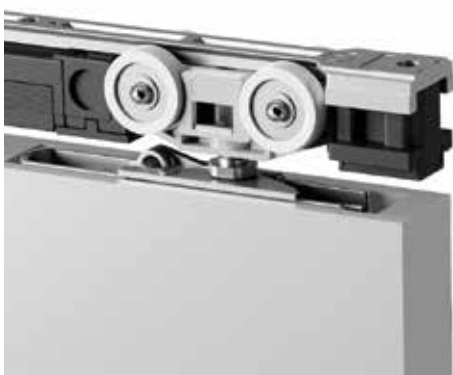

Gli ammortizzatori in apertura e chiusura consentono una ottimale frenatura e silenziosità. Per porte min. 70 cm

*The soft closing / opening dampers are available for an optimal braking motion and noiseless sliding quality. For doors 70 cm min.*

# TECHNICAL NOTES

## *Swing door*

DOOR SECTION



OPENING



STANDARD

DESIGN OPTIONS



---

SINGLE SWING DOOR



TRIPLE JAMB

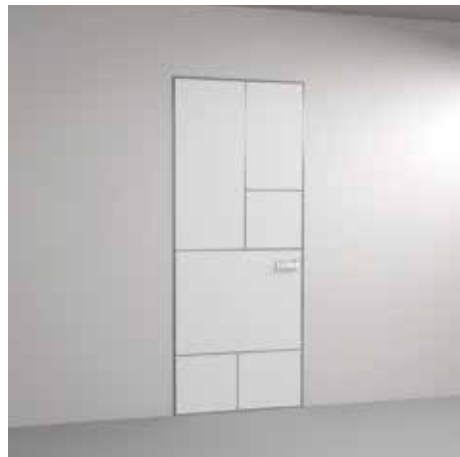

FILOMURO JAMB

---

DOUBLE SWING DOOR



TRIPLE JAMB



FILOMURO JAMB

---

LAND BOISERIE PANEL - ONE FINISH

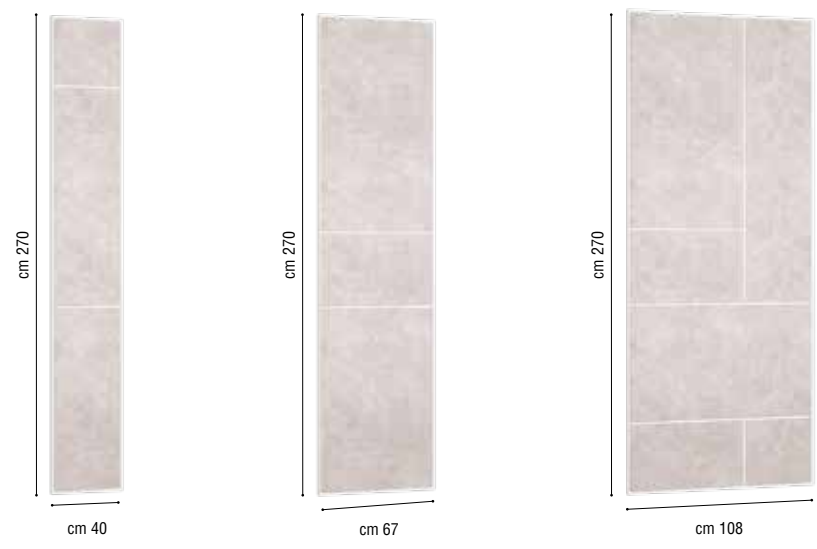

---

LAND BOISERIE PANEL - TWO FINISHES



# LAND BOISERIE

## *design options*

THE SERIES INCLUDES MANY  
COMBINATIONS AND DIFFERENT  
SIZED MODULES, FOR AN ALMOST  
PERSONALISED RESULT.

(for more details see page 348)

*La serie comprende molteplici abbinamenti e modularità dalle dimensioni personalizzate.  
(per approfondimenti vedere pag. 348)*

*Серия включает многочисленные сочетания и модульные решения с практически индивидуальными размерами.  
(более подробно см. на стр. 348)*

此系统以模块区分，可有不同宽度的搭配并可当作可开的面板使用。  
(详见第348页)









SLIDING PANELS | LAND  
STRUCTURE | BRIGHT ALUMINIUM  
PANELS | P.3 TECSUEDE 1043 + STOP SOL BRONZE  
HANDLE INSERT | BARDIGLIO NUVOLATO MARBLE



SLIDING PANELS | LAND  
STRUCTURE | BRIGHT CHAMPAGNE GOLD  
PANELS | P.3 TECSUEDE 5311 + STOP-SOL BRONZE  
HANDLE INSERT | CALACATTA MARBLE  
BOISERIE LAND | P.3 TECSUEDE 5311

ONE FINISH



TWO FINISHES







SLIDING PANELS | LAND  
STRUCTURE | BRIGHT CHAMPAGNE GOLD  
PANELS | MATT DARK CANALETTO WALNUT  
HANDLE INSERT | CALACATTA MARBLE  
BOISERIE LAND | P.3 TECSUEDE 5311



SLIDING PANELS | LAND  
STRUCTURE | BRIGHT CHAMPAGNE GOLD  
PANELS | GLOSSY LACQUERED TEMPERED COFFEE GLASS  
HANDLE INSERT | GLOSSY EBONY  
BOISERIE | P.3 TECSUEDE 1043





HANDLE WITH LEATHER INSERT

SLIDING PANEL | LAND  
STRUCTURE | BRIGHT ALUMINIUM  
PANELS | GLOSSY LACQUERED TEMPERED WHITE GLASS  
HANDLE INSERT | P.3 TECSUEDE 5311





# TRIPLE *jamb*

LAND DOOR USHERS IN A NEW TYPE OF JAMB: “TRIPLE”, BOTH LINEAR AND ELEGANT, WHICH CAN PERFECTLY ADAPT TO MINIMAL, MODERN SPACES. THREE CLEAR-CUT “STEPS” GIVE THE DOOR A GEOMETRIC FRAME.

Con la porta Land nasce anche un nuovo stipite: “Triple” che risulta essere lineare quanto elegante, riuscendo così ad adattarsi perfettamente a spazi minimal e moderni. Tre gradini netti che sporgono dal vano disegnando geometricamente la porta.

Вместе с дверью Land рождается и новая дверная коробка - «Triple». Она отличается линейностью и элегантностью и является прекрасным решением для минималистичных и современных помещений. Три чистые ступеньки выступают из проема, геометрически очерчивая дверь.

偕同Land门，诞生了一款新门框：「Triple」，简洁线型却极度优雅，如此得以完美适应极简风格或当代时尚的空间。三阶的层次从空间中突出，用几何绘制出门的轮廓。





POCKET SLIDING PANEL | LAND  
JAMB | TRIPLE  
STRUCTURE | MATT SATINED BRONZE ALUMINIUM  
PANELS | GLOSSY LACQUERED TEMPERED ROPE GLASS  
HANDLE INSERT | P.9 NABUCK 8028

# TECHNICAL NOTES

## *TRIPLE jamb*

SWING DOOR WITH TRIPLE JAMB



POCKET SLIDING DOOR WITH TRIPLE JAMB



SWING DOOR | LAND  
JAMB | TRIPLE  
STRUCTURE | BRIGHT CHAMPAGNE GOLD  
PANELS | STOP-SOL BRONZE  
HANDLE INSERT | SILVER WAVE MARBLE







SWING DOOR | LAND  
JAMB | TRIPLE  
STRUCTURE | BRIGHT DARK BROWN ELECTROCOLOUR  
PANELS | P.3 TECSUEDE 5311  
HANDLE INSERT | P.3 TECSUEDE 5311



# CORK *natural waves*

LUXURY COMBINES WITH NATURAL MATERIALS. CORK IS MADE INTERESTING WITH METAL BASES AND REFLECTIONS, WITH SOPHISTICATED AND UNEXPECTED IRRIDESCENT EFFECTS, THAT UNFOLD MASTERFULLY ON THE WALLS: A GLITTERING FINISH RESULTING FROM A HANDCRAFTED PROCESS.

Il lusso si unisce a materiali naturali. Il sughero viene animato da fondi e riflessi metallizzati, dagli effetti cangianti, sofisticati ed imprevedibili e si dispiega con maestria sulle pareti: una finitura scintillante tessuta manualmente.

Роскошь объединяется с натуральными материалами. Пробка оживляется металлизированными фонами и отблесками, переливчатыми, утонченными и непредсказуемыми эффектами и искусно располагается на стенах: сверкающая отделка, сотканная вручную.

奢侈与天然材料结合。软木，由底色与金属反光，由虹彩、讲究与无可预期的效果展现亮眼特色，以优雅的气度在墙面中延展：一种以手工编织，闪闪发光的面饰。

BROWN ON GOLD BASE CORK



BRONZE ON SILVER BASE CORK



BROWN ON SILVER BASE CORK







SWING DOOR | LAND  
JAMB | TRIPLE  
STRUCTURE | MATT SATINED BRONZE  
PANELS | BRONZE ON SILVER BASE CORK  
HANDLE INSERT | BRASS FUSION



SWING DOOR | LAND  
JAMB | TRIPLE  
STRUCTURE | BRIGHT CHAMPAGNE GOLD  
PANELS | MATT ERABLE  
HANDLE INSERT | P.3 TECSUEDE 5119

# WOOD *stylish veneer*

ATTENTION TO DETAIL COMBINES WITH THE USE OF EXCLUSIVE MATERIALS: IN-DEPTH KNOWLEDGE IS NEEDED TO USE THE RIGHT WOODWORKING TECHNIQUE TO FOLLOW ITS GRAIN IN A NATURAL WAY.

L'attenzione al dettaglio si coniuga con l'uso di materiali esclusivi: è la conoscenza dei materiali che richiede la giusta tecnica nel trattamento di un legno che sa seguire con naturalezza le sue venature.

Внимание к деталям сочетается с использованием эксклюзивных материалов: глубокое знание материалов позволяет использовать правильные методы обработки дерева, естественным образом повторяющие его текстуру.

关注所有细节与使用独特材料相互结合。是清楚了解木材并自然地循着木材纹路，以正确技术进行处理的成果。

ERABLE



LIGHT CANALETTO WALNUT



NEWOOD EBONY



MEDIUM CANALETTO WALNUT



EUCALYPTUS



DARK CANALETTO WALNUT







SWING DOOR | LAND  
JAMB | TRIPLE  
STRUCTURE | MATT SATINED BRONZE  
PANELS | GLOSSY NEWOOD EBONY  
HANDLE INSERT | P.3 TECSUEDE 5311

# TECHNICAL NOTES

*full-height door*

FULL-HEIGHT DOOR WITH UPPER JAMB

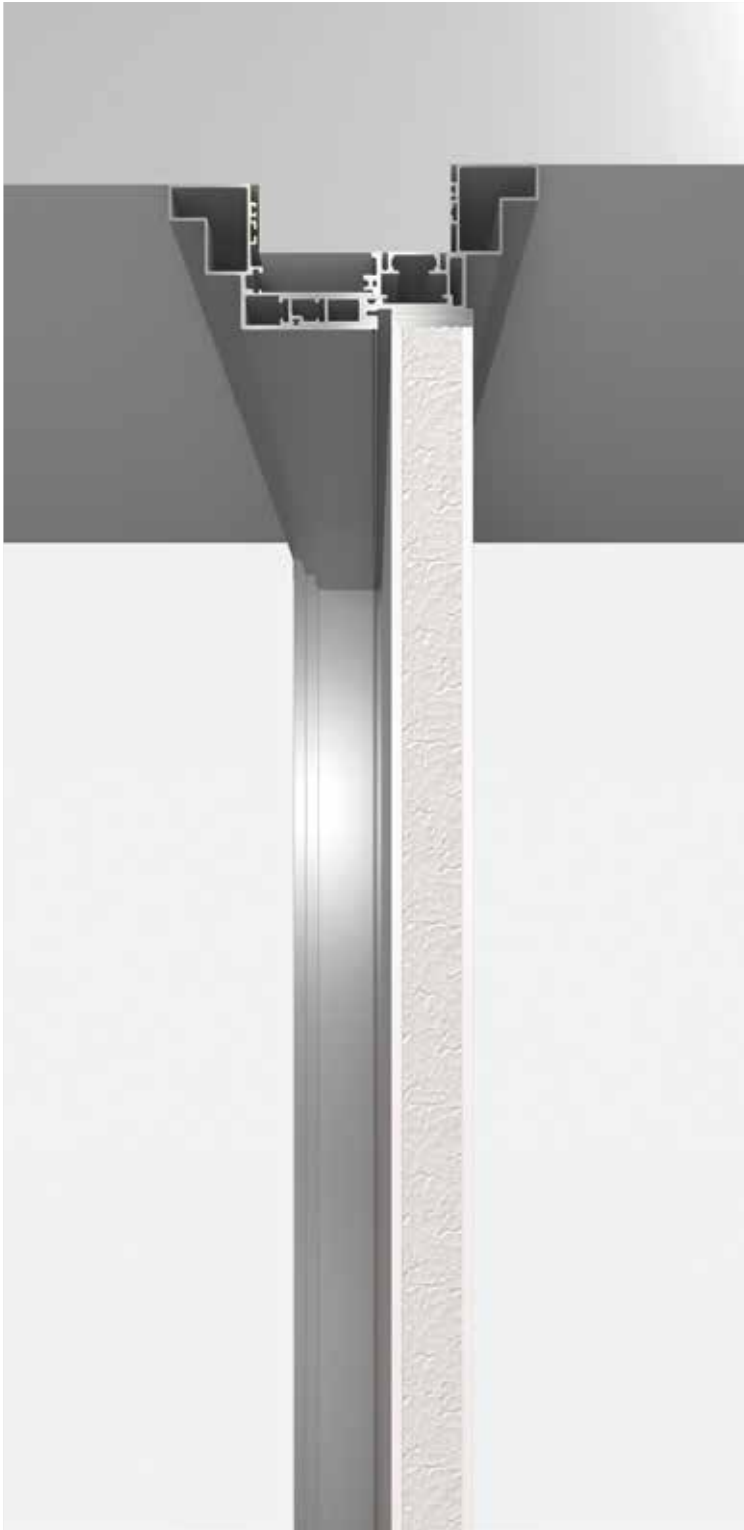

FULL-HEIGHT DOOR WITHOUT UPPER JAMB



FULL-HEIGHT DOOR VERSION APPLICABLE TO ALL LONGHI JAMBS



A dark red, monochromatic photograph of a modern interior wall. The wall features a door handle and paneling. The text is overlaid on the left side of the image.

LUXURY COMBINES  
WITH NATURAL  
MATERIALS.



SWING DOOR | LAND  
JAMB | TRIPLE  
STRUCTURE | MATT SATINED BRONZE  
PANELS | GLOSSY LACQUERED TEMPERED TURTLE DOVE GLASS  
HANDLE INSERT | P.3 TECSUEDE 1043

# TECHNICAL NOTES

## *FILOMURO jamb / FREE jamb*

SWING DOOR WITH FILOMURO JAMB

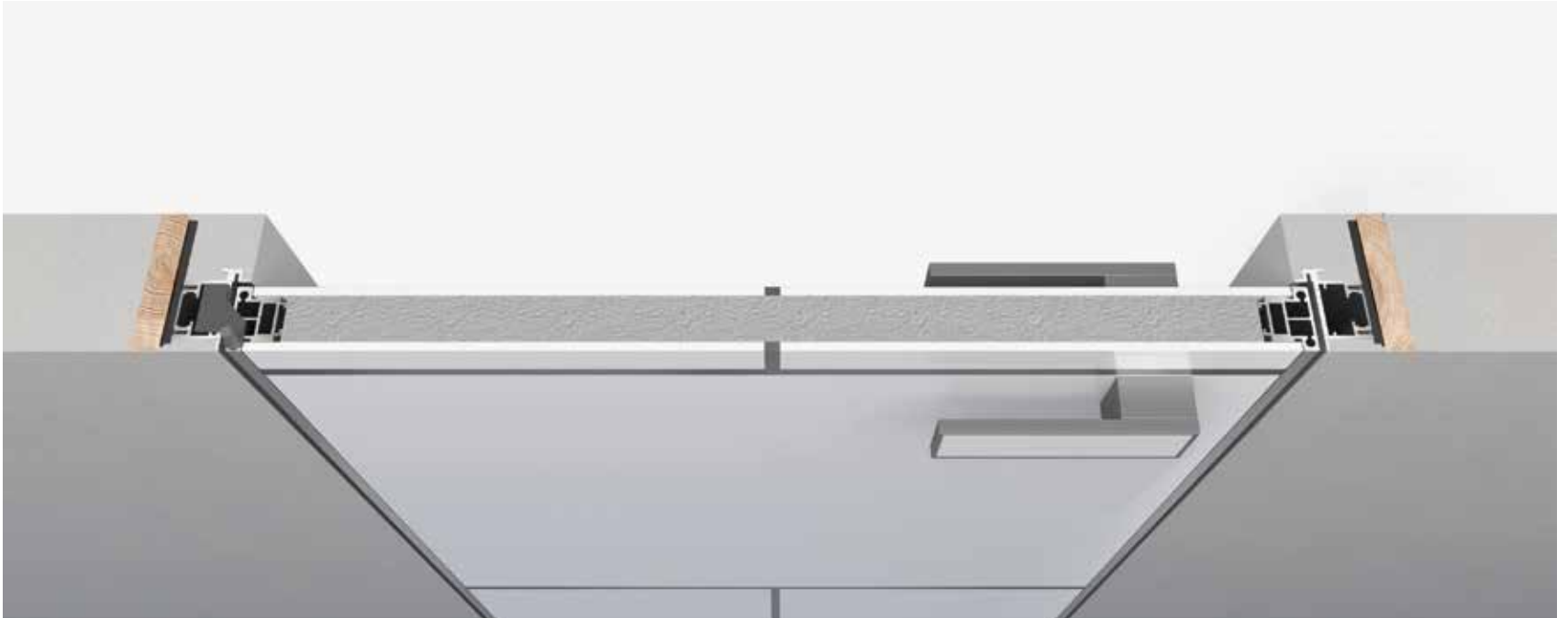

POCKET SLIDING DOOR WITH FREE JAMB



SWING DOOR | LAND  
JAMB | FILOMURO  
STRUCTURE | BRIGHT ALUMINIUM  
PANELS | GLOSSY LACQUERED TEMPERED WHITE GLASS  
HANDLE INSERT | GLOSSY LACQUERED TEMPERED WHITE GLASS

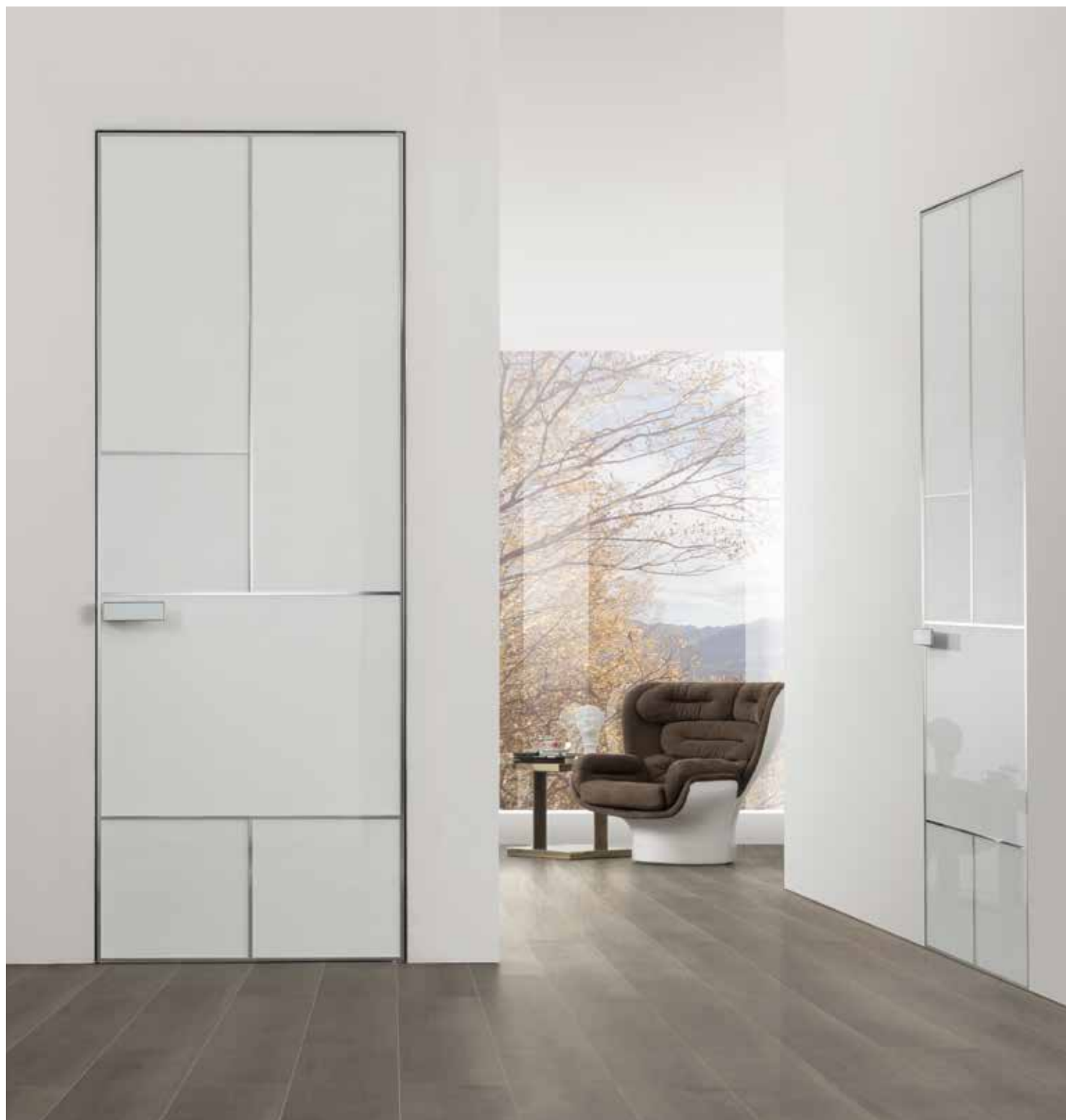



SWING DOOR | LAND  
JAMB | FILOMURO  
STRUCTURE | BRIGHT ALUMINIUM  
PANELS | P.3 TECSUEDE 5311  
HANDLE INSERT | BARDIGLIO NUVOLATO MARBLE





NEVER-ENDING  
COMPOSITION OPTIONS  
AND INNOVATIVE  
TECHNOLOGIES.

# TECHNICAL NOTES

## *Aluminium enlargement pads on TRIPLE jamb* FOR GLOSSY FINISHES

CM 10 - CM 12,7

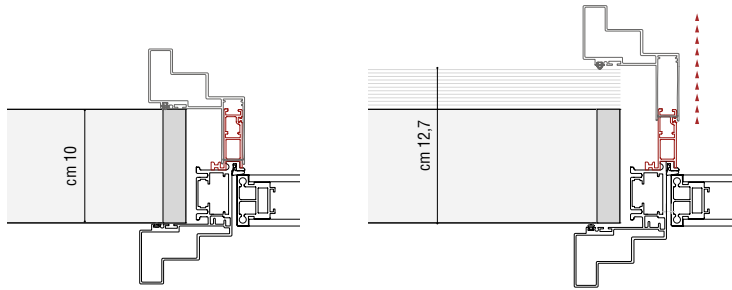

CM 12,8 - CM 17,5

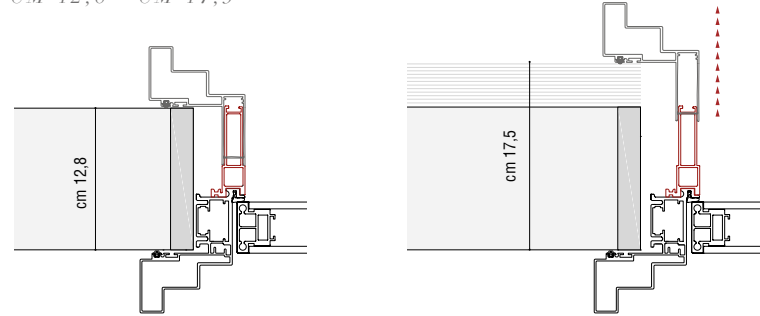

CM 17,6 - CM 20

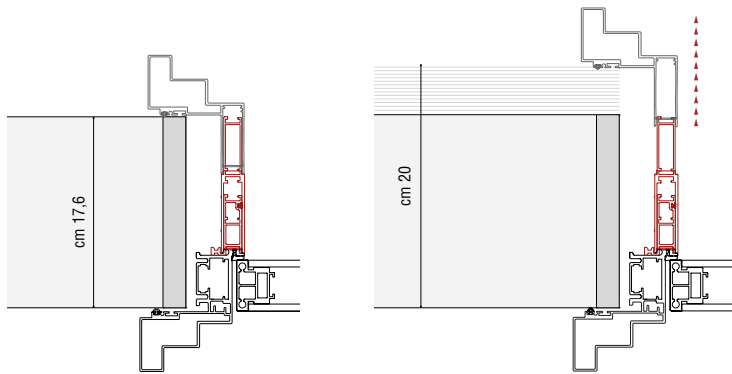

CM 20,1 - CM 24

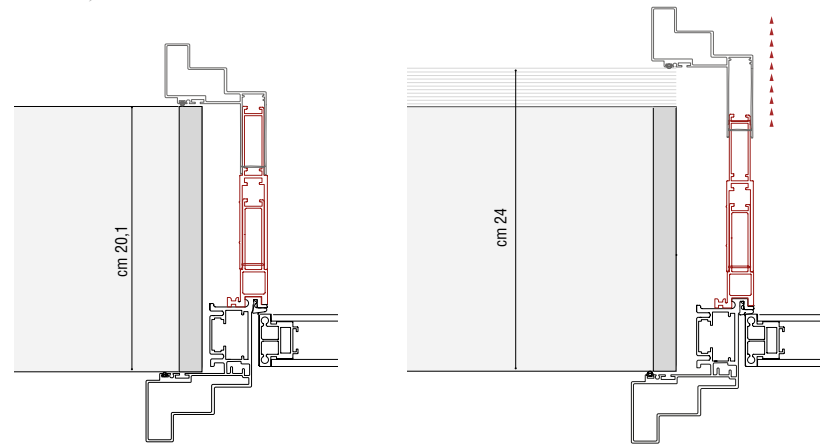

## *Wooden enlargement pads on TRIPLE jamb* FOR MATT FINISHES

CM 10 - ONWARDS

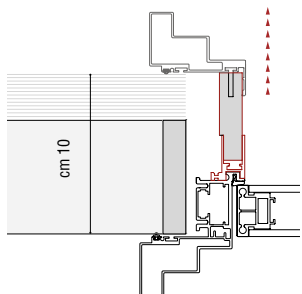

# TECHNICAL NOTES

## *Land finishes*

---

### STRUCTURE AND JAMB

#### *Aluminium*



MATT SATINED BRONZE    BRIGHT CHAMPAGNE GOLD    BRIGHT DARK BROWN ELECTROCOLOUR    BRIGHT ALUMINIUM    MATT DARK BROWN ELECTROCOLOUR

#### *Matt lacquered aluminium*



WHITE    CANAPA    ROPE    TURTLE DOVE    COFFEE    MOKA    PRUN    CEMENT GREY



LEAD GREY    GRANITE    SLATE GREY    NIGHT BLUE    BLACK

---

### PANEL

#### *Semi-reflective glass*



STOP-SOL BRONZE    STOP-SOL GREY

#### *Transparent glass*



TEMPERED DARK FUMÉ

#### *Mirrors*



MIRROR    BRONZE MIRROR    SMOKY MIRROR    FROSTED BRONZE MIRROR    FROSTED SMOKY MIRROR

#### *Cork*



BROWN ON GOLD BASE    BROWN ON SILVER BASE    BRONZE ON SILVER BASE

---

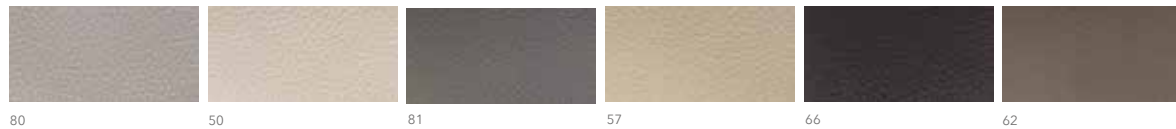
**PANEL AND INSERTS**
*Glossy lacquered tempered glass**Glossy-matt wood**Tecsuede Cat. P3**Eco-leather Cat. P3*

# TECHNICAL NOTES

## handle

### HANDLE FOR SWING DOOR



### HANDLE FOR SLIDING DOOR



Inserts can be in the same finish of the panel or as per the special finishes listed on the right page.  
*Gli inserti possono essere nella medesima finitura dell'anta o nelle finiture speciali elencate a destra.*

### MAGNETIC LOCK



SIMPLE LOCK



LOCK WITH LATCH

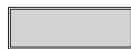

LOCK WITH KEY

### HANDLE STRUCTURE FINISH

#### Aluminium

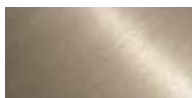

MATT SATINED BRONZE



BRIGHT CHAMPAGNE GOLD



BRIGHT DARK BROWN  
ELECTROCOLOUR



BRIGHT ALUMINIUM



MATT DARK BROWN  
ELECTROCOLOUR

#### Matt lacquered finish

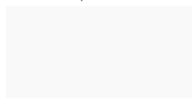

WHITE



CANAPA



ROPE



TURTLE DOVE



COFFEE



MOKA



PRUN



CEMENT GREY



LEAD GREY



GRANITE



SLATE GREY



NIGHT BLUE



BLACK

---

## SPECIAL HANDLE INSERT

### Onyx and marbles insert



RED ONYX



HONEY ONYX



IVORY ONYX



WHITE ONYX



GREEN ONYX

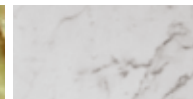

WHITE CARRARA MARBLE



IMPERIAL BROWN MARBLE



BARDIGLIO NUVOLATO MARBLE



VERDE GUATEMALA MARBLE



EMPERADOR DARK MARBLE



SILVER WAVE MARBLE



AGATHA BLACK MARBLE



ROSSO LEVANTO MARBLE



DOVER WHITE MARBLE



CALACATTA MARBLE



FRAPPUCCINO MARBLE



FUSION MULTICOLOR MARBLE

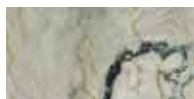

FUSION LIGHT MARBLE



PORTORO MARBLE



PATAGONIA MARBLE



JULIET PINK QUARTZ



BEOLA

### Hand engraved insert



HAND ENGRAVED CAST BRASS



HAND ENGRAVED SILVER ALUMINIUM

# IANUS

designed by Alessandro La Spada | Serie 340

Ianus è un programma mutevole, riflette i luoghi e le atmosfere, cambia natura, raccoglie le suggestioni di tanti mondi possibili, ne accetta i contrasti e li trasforma in un insieme elegante e calibrato. Ha, alla propria origine, un concept forte e determinato che lo porta ad essere essenziale ed al tempo stesso, per complessità e sicurezza di linguaggio, esuberante, ricco, sontuoso. Ianus decodifica il gusto contemporaneo e cosmopolita e lo ricompono, senza mezzi termini o indecisioni, in un insieme di colori e materiali preziosi in un'unica, esclusiva, inimitabile idea di lifestyle.

*Ianus is a versatile system that reflects the places and atmospheres it occupies, then changes its character, taking its cues from many possible worlds, accepts their differences and blends them into an elegant and balanced whole. It springs from a bold, original concept that lends it an essential and, at the same time exuberant, opulent, and sumptuous feel - thanks to the complexity and confidence of its architectural language. Ianus translates contemporary, cosmopolitan taste in unequivocal and well-defined terms through a combination of colors and precious materials, producing a unique, exclusive, unrivalled lifestyle concept.*

*Ianus - это изменчивый проект, который отражает места и окружение, меняет свой характер, объединяет очарование множества возможных миров, принимает их контрасты и преобразует их в элегантный и гармоничный ансамбль. В основе проекта лежит сильная и четкая концепция, придающая ему строгость, но в то же время пышность, богатство и великолепие, достигаемые благодаря сложной и уверенной форме выражения. Ianus расшифровывает современный космополитический вкус и решительно и уверенно преобразует его в ансамбль из оттенков и ценных материалов, создавая уникальную, эксклюзивную, неподражаемую идею стиля жизни.*

Ianus是一套可变的系列产品，反映出场地与气氛，变化其自然性质，集取众多世界的建议，而后接受反差并将之转变成优雅与均衡的集成。它源自强烈且明确的概念，在拥有实质性本质的同时，也因其繁复与足以自傲的建筑结构，展现丰富、华丽与阔气的特质。Ianus将当代与都会品味破解后再将之重新组合，果断且毫不迟疑地，以配色与珍贵材料，组合出独一无二、专属的、无可仿效的生活风尚理念。







SLIDING PANELS | IANUS  
STRUCTURE | MATT SATINED BRONZE  
PANELS | STOP-SOL BRONZE  
HANDLE INSERT | WHITE ONYX  
ENDLESS BOISERIE | P.3 TECSUEDE 5311

# TECHNICAL NOTES

## *sliding door*

### DOOR SECTION



### DESIGN OPTIONS



---

SLIDING DOOR WITH RAIL



WALL SLIDING

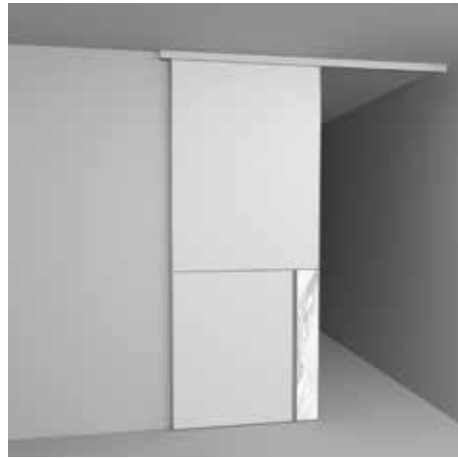

CEILING SLIDING

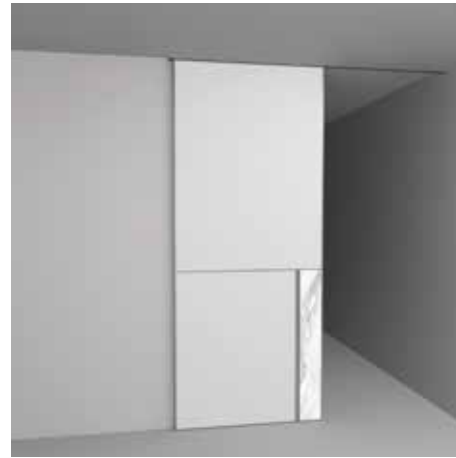

CEILING BUILT-IN SLIDING

---

POCKET SINGLE DOOR



LOTO JAMB



RELIEF JAMB



FREE JAMB

---

POCKET DOUBLE DOOR



LOTO JAMB



RELIEF JAMB



FREE JAMB

# TECHNICAL NOTES

## *modular system*

TRAVI DI SCORRIMENTO A SOFFITTO CON MASCHERINA 1 VIA  
*One way ceiling sliding rails with visible closing cover*



TRAVI DI SCORRIMENTO AD INCASSO A SOFFITTO A 1 VIA  
*One way ceiling built-in sliding rails*

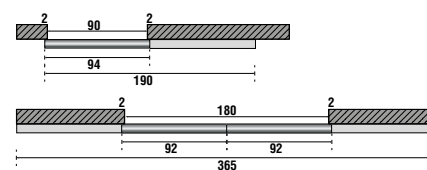

TRAVI DI SCORRIMENTO A SOFFITTO CON MASCHERINA 2 VIE  
*Two way ceiling sliding rails with visible closing cover*



TRAVI DI SCORRIMENTO AD INCASSO A SOFFITTO A 2 VIE  
*Two way ceiling built-in sliding rails*

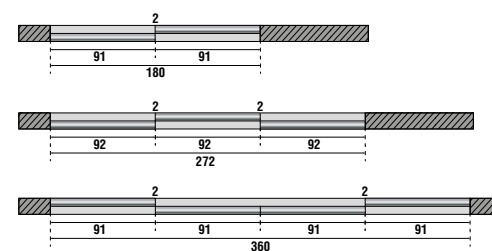

TRAVI DI SCORRIMENTO A SOFFITTO CON MASCHERINA 3 VIE  
*Three way ceiling sliding rails with visible closing cover*



TRAVI DI SCORRIMENTO AD INCASSO A SOFFITTO A 3 VIE  
*Three way ceiling built-in sliding rails*

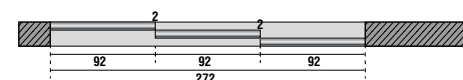

TRAVI DI SCORRIMENTO A PARETE CON MASCHERINA 1 VIA  
*One way wall sliding rails with visible closing cover*



TRAVI DI SCORRIMENTO A PARETE AD INCASSO 1 VIA  
*One way wall built-in sliding rails*

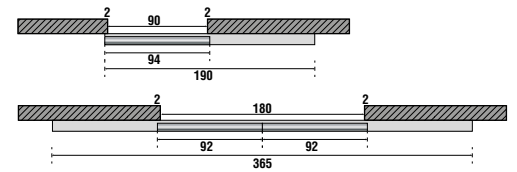

TRAVI DI SCORRIMENTO A PARETE CON MASCHERINA 2 VIE  
*Two way wall sliding rails with visible closing cover*



TRAVI DI SCORRIMENTO A PARETE AD INCASSO 2 VIE  
*Two way wall built-in sliding rails*

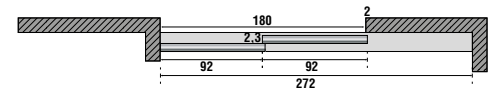

## *Soft opening / Soft close*

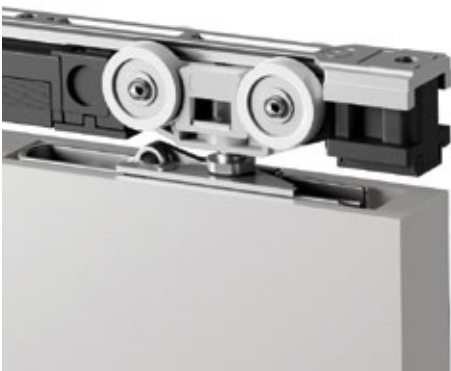

Gli ammortizzatori in apertura e chiusura consentono una ottimale frenatura e silenziosità. Per porte min. 70 cm

*The soft closing / opening dampers are available for an optimal braking motion and noiseless sliding quality. For doors 70 cm min.*

# TECHNICAL NOTES

## *Swing door*

### DOOR SECTION



### OPENING



STANDARD



BI-DIRECTIONAL

### DESIGN OPTIONS



FULL PANEL



PANEL WITH  
ALUMINIUM PROFILE



COVERED BEVELLED PANEL



COVERED STITCHED PANEL

---

SINGLE SWING DOOR



LOTO JAMB



RELIEF JAMB



FILOMURO JAMB

---

DOUBLE SWING DOOR



LOTO JAMB



RELIEF JAMB



FILOMURO JAMB

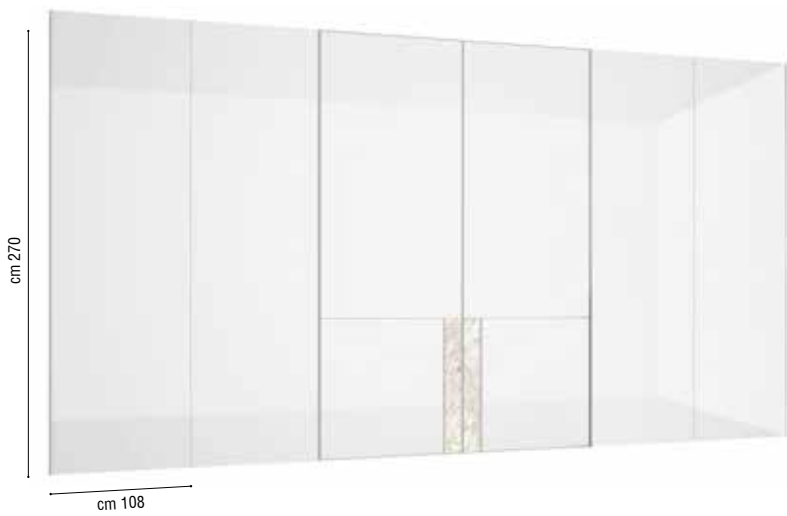
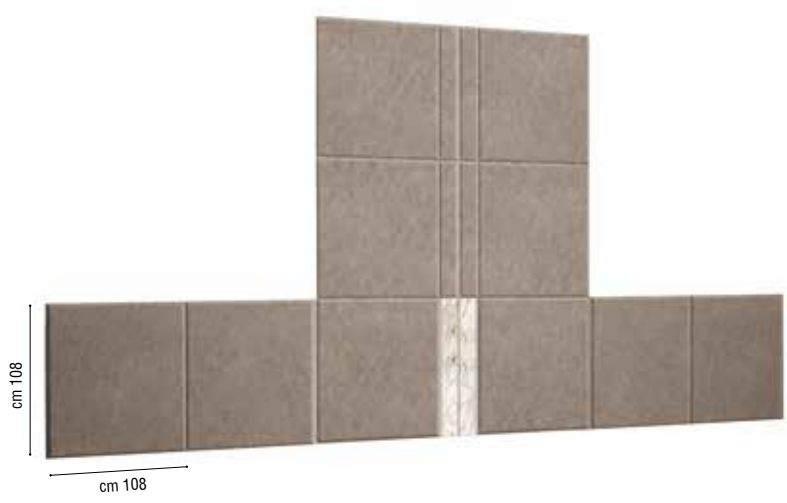

# ENDLESS BOISERIE

*design options*

MAXIMUM ADAPTABILITY, EXPRESSED  
IN THREE TYPES OF CONFIGURATIONS.  
A WALL COVERING COMBINABLE WITH  
ALL LONGHI DOORS.

(for more details see page 366)

La boiserie Endless ha plurimi aspetti di adattabilità, espressi in tre tipologie estetiche.  
Posizionata come rivestimento di pareti e abbinabile a tutte le porte Longhi impreziosisce  
l'ambiente.  
(per approfondimenti vedere pag. 366)

Буазери "Endless" отличается высокой адаптируемостью благодаря трем вариантам  
отделки.  
При использовании для облицовки стен и в сочетании со всеми дверями Longhi придает  
особую ценность помещению.  
(более подробно см. на стр. 366)

Endless 墙面镶板有多重适应的特性，共有三种类型。  
可以作为墙面的覆面材料与所有 Longhi 门组合，点缀环境。  
(详见第366页)



SLIDING PANELS | IANUS  
STRUCTURE | BRIGHT CHAMPAGNE GOLD  
PANELS | MATT SLATTED ERABLE  
HANDLE INSERT | PEARL SATIN EMBROIDERY  
ENDLESS BOISERIE | MATT SLATTED ERABLE







SLIDING PANELS | LAND  
STRUCTURE | BRIGHT CHAMPAGNE GOLD  
PANELS | P.3 TECSUEDE 5120  
HANDLE INSERT | CALACATTA MARBLE  
BOISERIE LAND | P.3 TECSUEDE 5120



# SLATTED *version*

THIS SYSTEM FEATURES EXCLUSIVE  
45-DEGREE OBLIQUE CRAFTSMANSHIP  
ON MATT WOOD FINISHES.

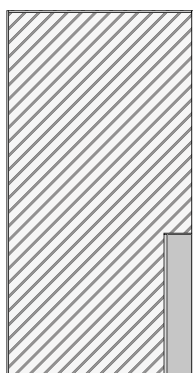

FULL PANEL

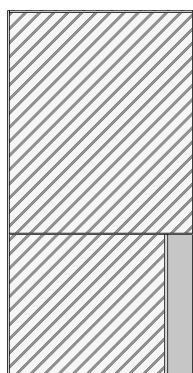

PANEL WITH  
ALUMINIUM PROFILE

Il sistema prevede un'esclusiva lavorazione obliqua a 45 gradi su finitura lignea opaca.

Система предусматривает эксклюзивную обработку с наклоном под 45 градусов на матовой отделке из дерева.

系统采用独特的 45 度倾斜加工，哑光木质饰面。

ERABLE

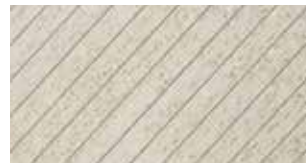

LIGHT CANALETTO WALNUT



MEDIUM CANALETTO WALNUT



DARK CANALETTO WALNUT

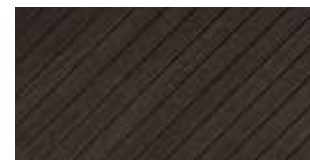



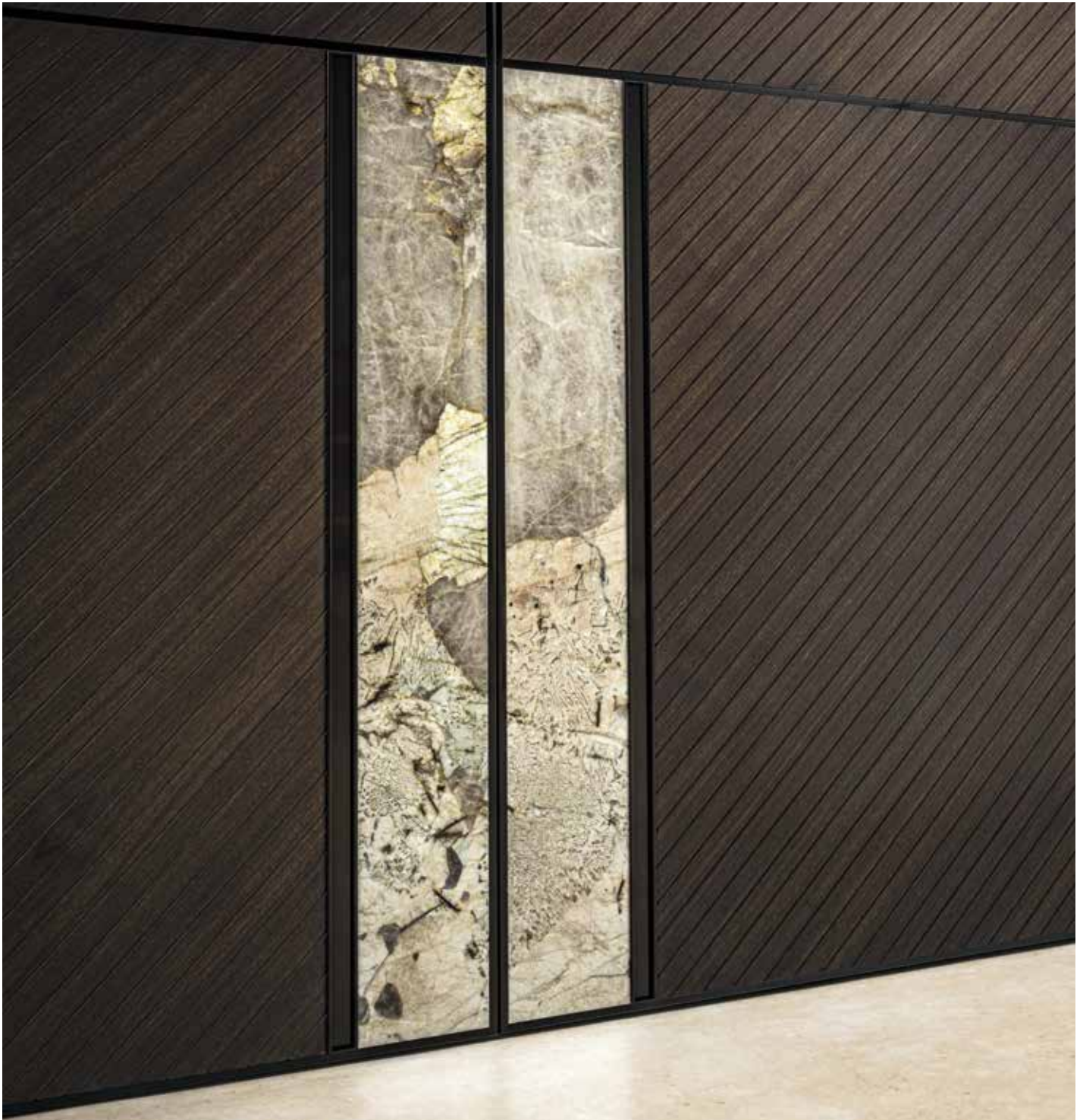

SLIDING PANELS | IANUS  
STRUCTURE | BRIGHT DARK BROWN ELECTROCOLOUR  
PANELS | MATT SLATTED DARK CANALETTO WALNUT  
HANDLE INSERT | PATAGONIA MARBLE



SLIDING PANELS | IANUS  
STRUCTURE | BRIGHT CHAMPAGNE GOLD  
PANELS | MATT SLATTED ERABLE  
HANDLE INSERT | PEARL SATIN EMBROIDERY





# *exclusive* GLASSES

EXCLUSIVE CRAFTSMANSHIP  
AND NEW COLOURS THAT COMBINE  
PERFECTLY FOR AN EXTREMELY  
ELEGANT EFFECT.

Esclusive lavorazioni e nuove colorazioni che si combinano perfettamente per un effetto estremamente elegante.

Эксклюзивные виды обработки и новые цветовые оттенки, идеально сочетающиеся с материалами вставок для получения эффекта невероятной элегантности.

独家工艺和新颜色与嵌件材料完美结合，营造出极其优雅的效果。

TAUPE "ASTRAKAN" GLASS



DOVE GREY "BARK" GLASS



PEWTER "LIZARD" GLASS

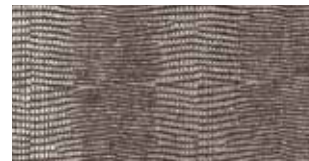

TEXTURED GLASS  
FOR MAXIMUM  
DESIGN FREEDOM.



SLIDING PANELS | IANUS  
STRUCTURE | MATT SATINED BRONZE  
PANELS | PEWTER "LIZARD" GLASS  
HANDLE INSERT | SILVER WAVE MARBLE



SLIDING PANELS | IANUS  
STRUCTURE | MATT SATINED BRONZE  
PANELS | TAUPE "ASTRAKAN" GLASS  
HANDLE INSERT | WHITE ONYX





SLIDING PANELS | IANUS  
STRUCTURE | BRIGHT CHAMPAGNE GOLD  
PANELS | P.3 TECSUEDE 5120  
HANDLE INSERT | PEARL SATIN EMBROIDERY

# SPECIAL SATIN *handle insert*

SILK THREAD EMBROIDERY ON A SATIN BASE FOR AN IRIDESCENT AND LUMINOUS EFFECT.

"SAND"  
SATIN  
EMBROIDERY



"LIGHT BLUE"  
SATIN  
EMBROIDERY



"GREY"  
SATIN  
EMBROIDERY



"PEARL"  
SATIN  
EMBROIDERY



Ricamo eseguito con filo di seta su base di raso per un effetto cangiante e luminoso.

Вышивка шелковой нитью по атласу, создающая переливчатый сияющий эффект.

在缎面底布上用丝线制成刺绣，呈现虹彩和发光效果。





SLIDING PANELS | IANUS  
STRUCTURE | BRIGHT DARK BROWN ELECTROCOLOUR  
PANELS | MATT SLATTED DARK CANALETTO WALNUT  
HANDLE INSERT | LIGHT BLUE SATIN EMBROIDERY



# “PALMA” *decoration*

EXCLUSIVE DECORATION BY  
ALESSANDRO LA SPADA,  
HAND-MADE WITH SATIN VARNISH  
ON STOP-SOL GLASS.



AVAILABLE DESIGN  
ON FULL PANEL ONLY

Esclusiva decorazione di Alessandro La Spada realizzata a mano con vernice satinata su vetro stop-sol.

Эксклюзивный декор по проекту Алессандро Ла Спада, выполненный вручную сатинированным лаком на стекле StopSol.

独家装饰由 Alessandro La Spada 手工制作，于 stop-sol 玻璃上涂以缎面清漆。

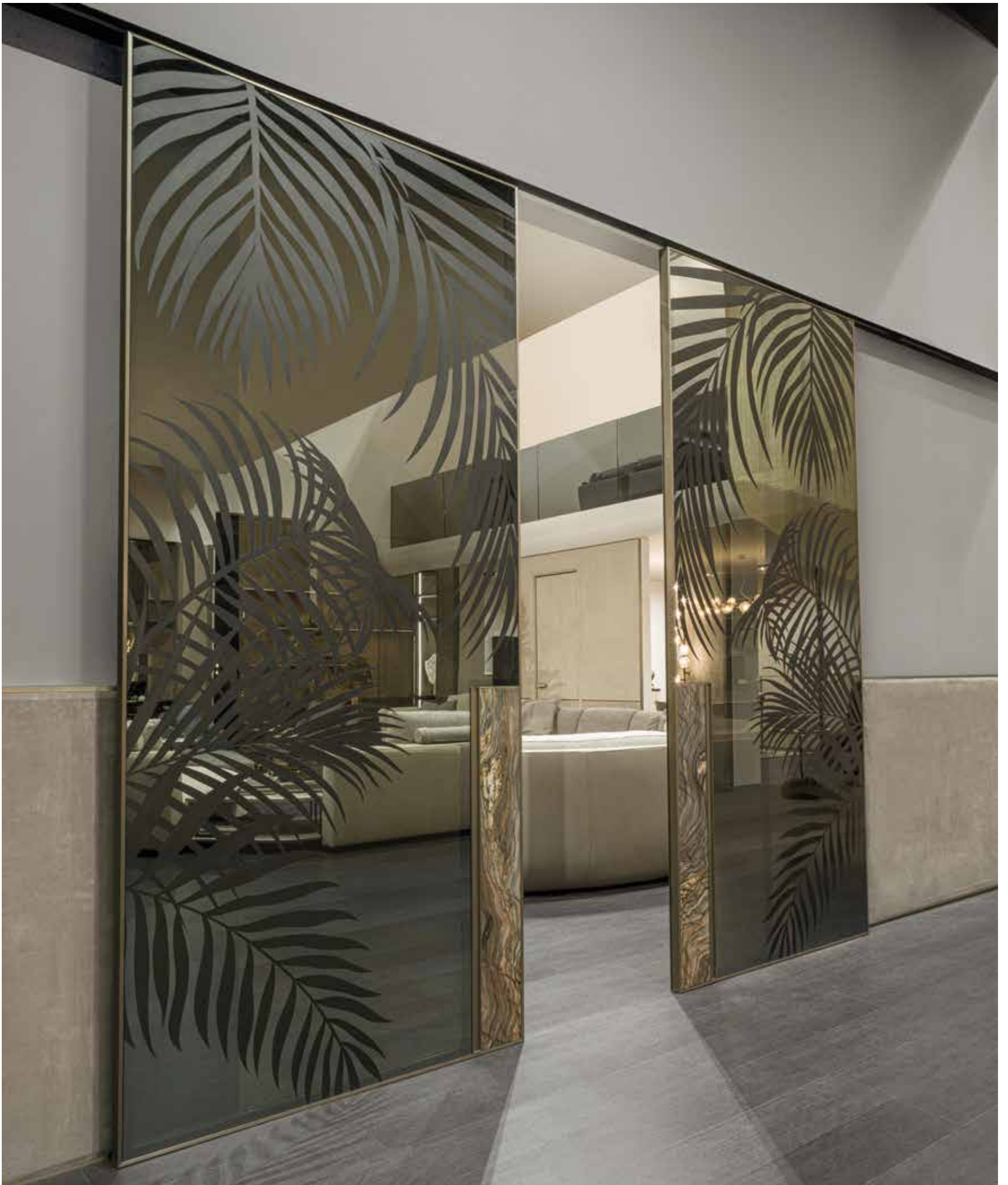



SLIDING PANELS | IANUS  
STRUCTURE | MATT SATINED BRONZE  
PANELS | BRONZE STOP-SOL GLASS WITH "PALM" DECORATION  
HANDLE INSERT | FUSION MULTICOLOR MARBLE



SLIDING PANELS | IANUS  
STRUCTURE | BRIGHT DARK BROWN ELECTROCOLOUR  
PANELS | "CRISTAL RAIN" BRONZE MIRROR  
HANDLE INSERT | CALACATTA MARBLE

# CRISTAL RAIN *exclusive design*

AN EXCLUSIVE DECORATIVE PATTERN  
CREATED FOR IANUS SYSTEM:  
A UNIQUE DESIGN TAKING  
DECORATION TO A NEW LEVEL.

Ianus

Per il sistema Ianus è stata sviluppata una decorazione esclusiva: "Cristal Rain". Una creazione unica, che amplia l'alto contenuto decorativo e crea un valore aggiunto.

Для системы Ianus был разработан эксклюзивный декор «Cristal Rain». Это уникальное творение усиливает высокодекоративный характер системы Ianus и подчеркивает ее красоту.

专为Ianus系统，特别开发了专属的「Cristal Rain」装饰。是一种独特的创作，为Ianus系统延伸了装饰内容的高度并创造出一种附加价值。

CRISTAL RAIN  
ON SMOKY MIRROR



CRISTAL RAIN  
ON BRONZE MIRROR





LIGHTNESS AND  
FORMAL ELEGANCE.



SLIDING PANELS | IANUS  
STRUCTURE | BRIGHT ALUMINIUM  
PANELS | "CRISTAL RAIN" SMOKY MIRROR  
HANDLE INSERT | FROSTED SMOKY MIRROR



SLIDING PANELS | IANUS  
STRUCTURE | GLOSSY WHITE ALUMINIUM  
PANELS | MATT LACQUERED TEMPERED WHITE GLASS  
HANDLE INSERT | GREEN ONYX





SLIDING PANELS | IANUS  
STRUCTURE | BRIGHT ALUMINIUM  
PANELS | STOP-SOL GREY  
HANDLE INSERT | BEOLA STONE



SLIDING PANELS | IANUS  
STRUCTURE | BRIGHT DARK BROWN ELECTROCOLOUR  
PANELS | P.3 TECSUEDE 1043  
HANDLE INSERT | CALACATTA MARBLE

# CLADDING

A SELECTION OF MATERIALS  
OFFERING MAXIMUM VERSATILITY.  
THE CHOSEN SHADES PERFECTLY  
MATCH WITH ALL THE EXCLUSIVE  
FINISHES OF THE COLLECTION.

ECO-LEATHER



TECSUEDE

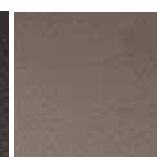
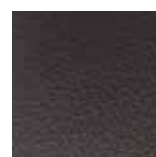
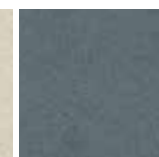
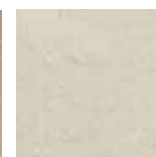
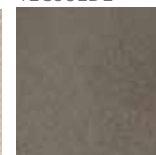

Selezione di materiali dalla massima versatilità. I toni scelti si abbinano perfettamente con tutti i materiali esclusivi della collezione.

Подборка в высшей степени универсальных материалов. Подобранные оттенки идеально сочетаются со всеми эксклюзивными материалами, выбранными для этой коллекции.

选用多功能材料。所选色调与为该系列精选的所有独家材料完美呼应。





SWING DOOR | IANUS  
JAMB | RELIEF  
STRUCTURE | MATT SATINED BRONZE  
PANELS | STOP-SOL BRONZE  
HANDLE INSERT | P.3 TECSUEDE 5311



# LOTO *jamb*

THE WAVY SHAPE OF “LOTO” JAMB WRAPS AROUND THE WALLS AND CHARACTERISES THE SYSTEM WITH ITS DISTINCTIVE IMPRINT.

Lo stipite Loto con la sua forma ondulata avvolge le pareti e caratterizza il sistema con la sua impronta distintiva.

Косяк “Loto” своей волнистой формой окутывает стены и обеспечивает неповторимость этой системы.

波浪形的莲花门框环绕着墙壁，以其独特的印记为系统赋予特色。

# TECHNICAL NOTES

## *LOTO jamb*

SWING DOOR WITH LOTO JAMB



POCKET SLIDING DOOR WITH LOTO JAMB





SWING PANEL | IANUS  
JAMB | LOTO  
STRUCTURE AND HANDLE | MATT DARK BROWN ELECTROCOLOUR  
PANEL | DOVE GREY "BARK" GLASS



BE UNIQUE IN THE  
MOST EXCLUSIVE WAY.



SWING PANEL | IANUS  
JAMB | LOTO  
STRUCTURE AND HANDLE | MATT SATINED BRONZE  
PANEL | STOP-SOL BRONZE



MATT SLATTED ERABLE

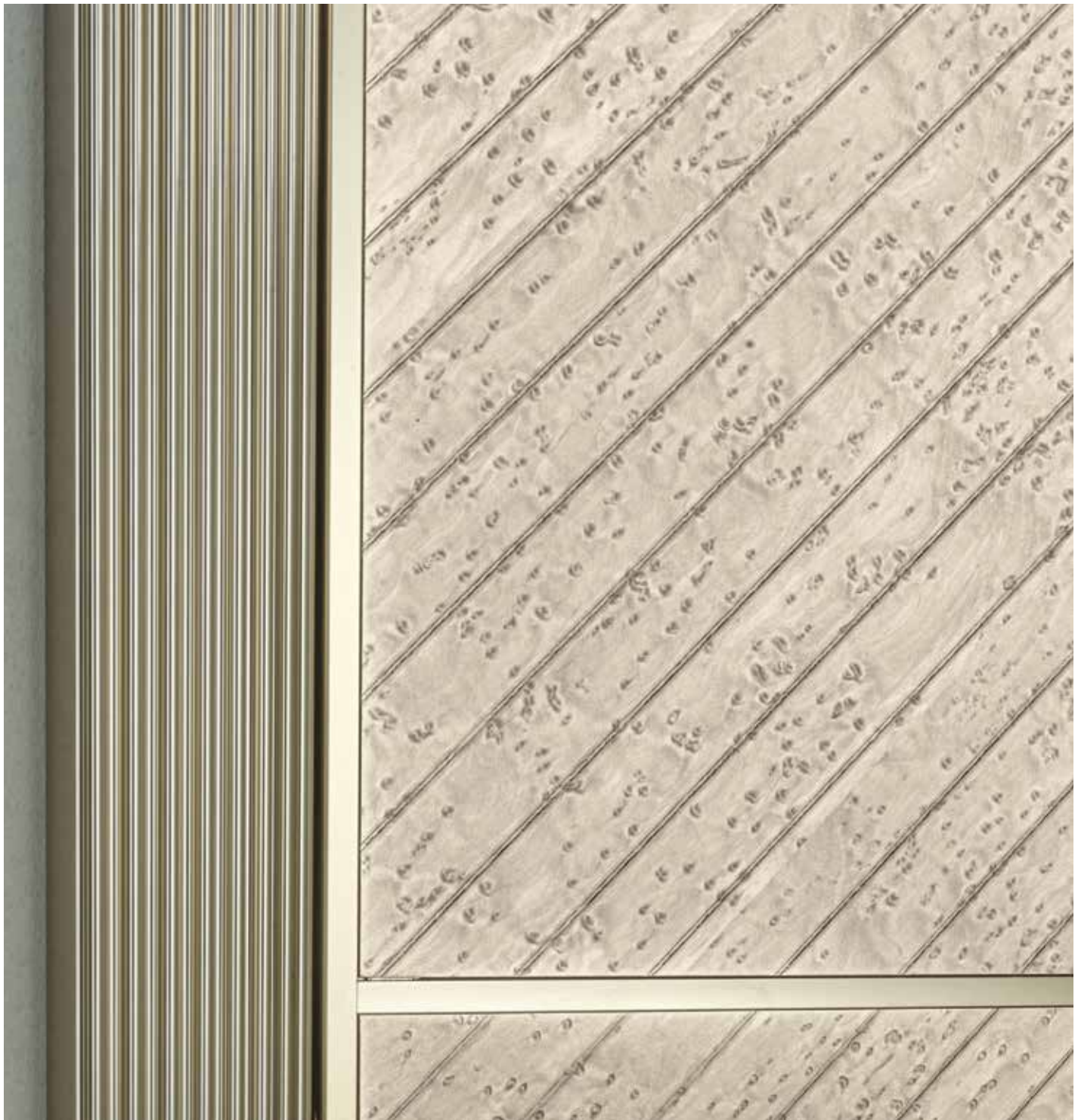

SWING DOOR | IANUS  
JAMB | LOTO  
STRUCTURE AND HANDLE | BRIGHT CHAMPAGNE GOLD  
PANEL | MATT SLATTED ERABLE



PLAIN GLOSSY ERABLE

SWING DOOR | IANUS  
JAMB | LOTO  
STRUCTURE AND HANDLE | BRIGHT CHAMPAGNE GOLD  
PANEL | GLOSSY ERABLE







SLIDING PANELS | IANUS  
STRUCTURE | BRIGHT CHAMPAGNE GOLD  
PANELS | MATT EUCALYPTUS  
HANDLE INSERT | BRASS FUSION

SWING PANEL | IANUS  
STRUCTURE AND HANDLE | BRIGHT CHAMPAGNE GOLD  
PANEL | MATT EUCALYPTUS  
BOISERIE ENDLESS | MATT EUCALYPTUS



# LOTO *handle*

A DISTINCTIVE, STRONG DESIGN  
DEVELOPED BY  
ALESSANDRO LA SPADA  
EXCLUSIVELY FOR LONGHI,  
IN LINE WITH LOTO JAMB.

La maniglia, in continuità con lo stipite, sottolinea il design deciso e caratteristico del sistema Loto firmato da Alessandro La Spada in esclusiva per Longhi.

*Ручка, выполненная в одном стиле с косяком, подчеркивает своеобразный решительный дизайн системы "Loto", разработанный Александром Ла Спада эксклюзивно для Longhi.*

把手与门框相连，突出了由 Alessandro Laspada 设计的莲花系统的果敢且特色的设计  
专为 longhi



# RELIEF *jamb*

THE CLASSIC DISTINCTIVE LINES  
OF RELIEF JAMB ARE A PERFECT  
FRAME FOR IANUS COLLECTION.

Le linee classiche e distintive dello stipite Relief sono una perfetta cornice per le porte della collezione Ianus.

Классические характерные очертания косяка "Relief" служат прекрасным обрамлением для дверей коллекции Longhi.

浮雕门框经典而独特的线条是 Longhi 系列门的完美框架。

# TECHNICAL NOTES

## *RELIEF jamb*

SWING DOOR WITH RELIEF JAMB



POCKET SLIDING DOOR WITH RELIEF JAMB









SWING DOOR IANUS + ENDLESS BOISERIE  
JAMB | RELIEF  
STRUCTURE | BRIGHT CHAMPAGNE GOLD  
PANELS | P.3 TECSUEDE 5105  
HANDLE INSERT | FRAPPUCCINO MARBLE  
ENDLESS BOISERIE | P.3 TECSUEDE 5105



# COVERED panels

IANUS DOOR CAN BE COVERED IN ECO-LEATHER OR TECSUEDE. THE PANEL CAN BE FLAT WITH CLASSIC STITCHING OR WITH THE TYPICAL DIAMOND-CUT BEVELLING.

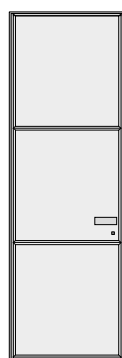

COVERED BEVELLED PANEL

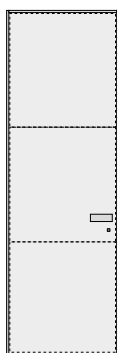

COVERED STITCHED PANEL



La porta Ianus può essere rivestita in Ecopelle o Tecsuede. Il pannello può essere piatto con classiche cuciture, oppure con tipica bisellatura taglio a diamante.

Дверь "Ianus" может обтягиваться экокожей или замшей. Панель может быть плоской с классическими стежками или же выполняться с традиционным скосом с алмазной гранью, характеризующим большую часть коллекции.

Ianus 门可以用生态皮革或 tecsuede 覆盖。面板可以采用经典缝线，也可以采用典型的钻石切割磨斜边，这体现在该系列的大部分产品中。



SWING DOOR | IANUS  
JAMB | RELIEF  
STRUCTURE | WHITE MATT LACQUERED  
PANELS | GLOSSY LACQUERED TEMPERED WHITE GLASS  
HANDLE INSERT | GREEN ONYX

# *Handle INSERT*

IANUS HANDLE IS AN EXCLUSIVE LONGHI DESIGN EMBELLISHED WITH AN INSERT MADE OF SPECIAL MATERIALS.

LEATHER



ONYX



STONE



MARBLE



GLASS



La maniglia Ianus è un design esclusivo Longhi ed è impreziosita da un inserto composto da materiali speciali.

ручка "Ianus" имеет эксклюзивный дизайн Longhi и украшена вставкой из особых материалов.

Ianus 把手是 Longhi 的独家设计，配以特殊材料制成的嵌饰。

FUSION



WOOD VENEER





SWING DOOR | IANUS  
JAMB | RELIEF  
STRUCTURE | BRIGHT ALUMINIUM  
PANELS | STOP-SOL GREY  
HANDLE INSERT | P.3 TECSUEDE 1012



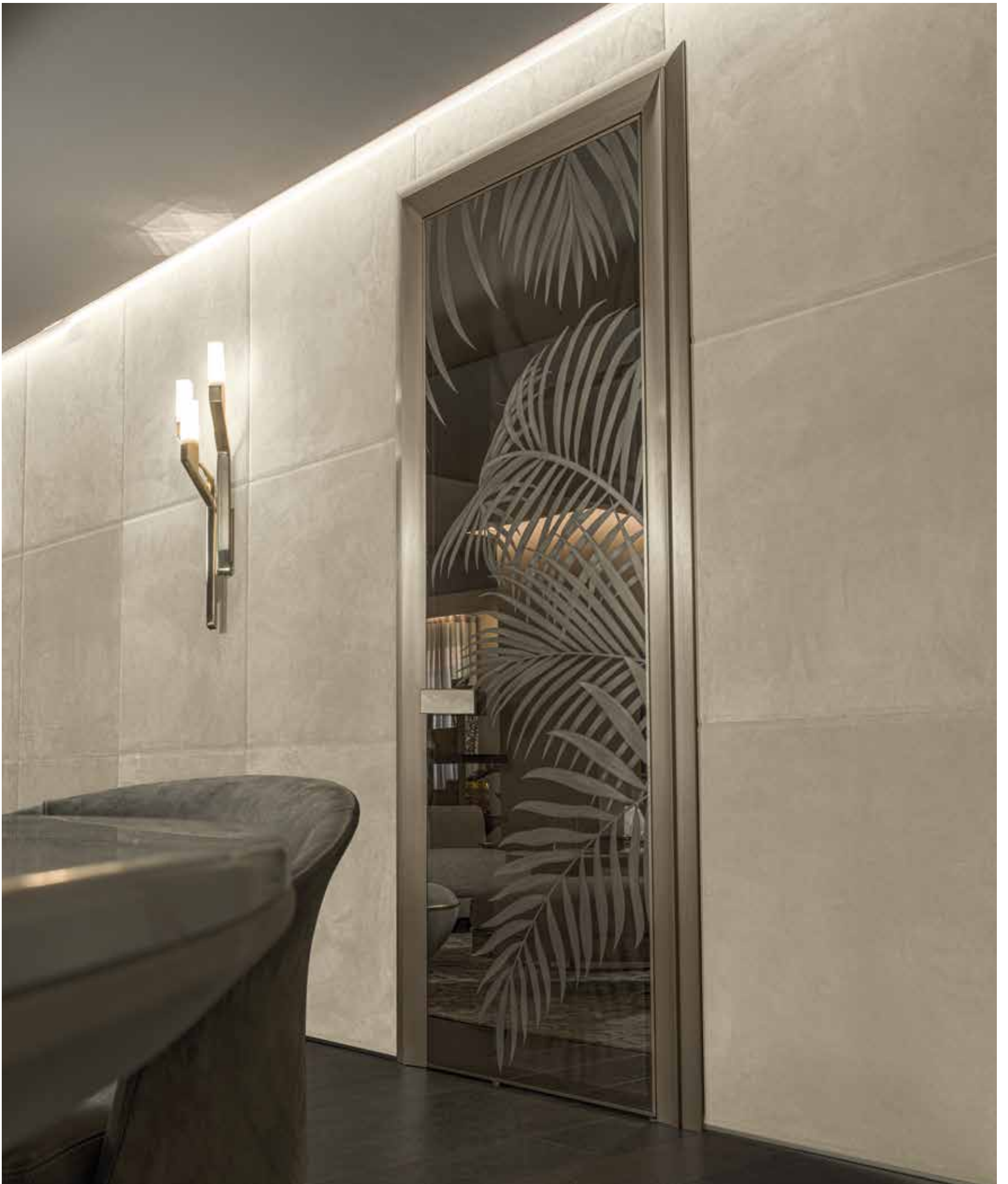

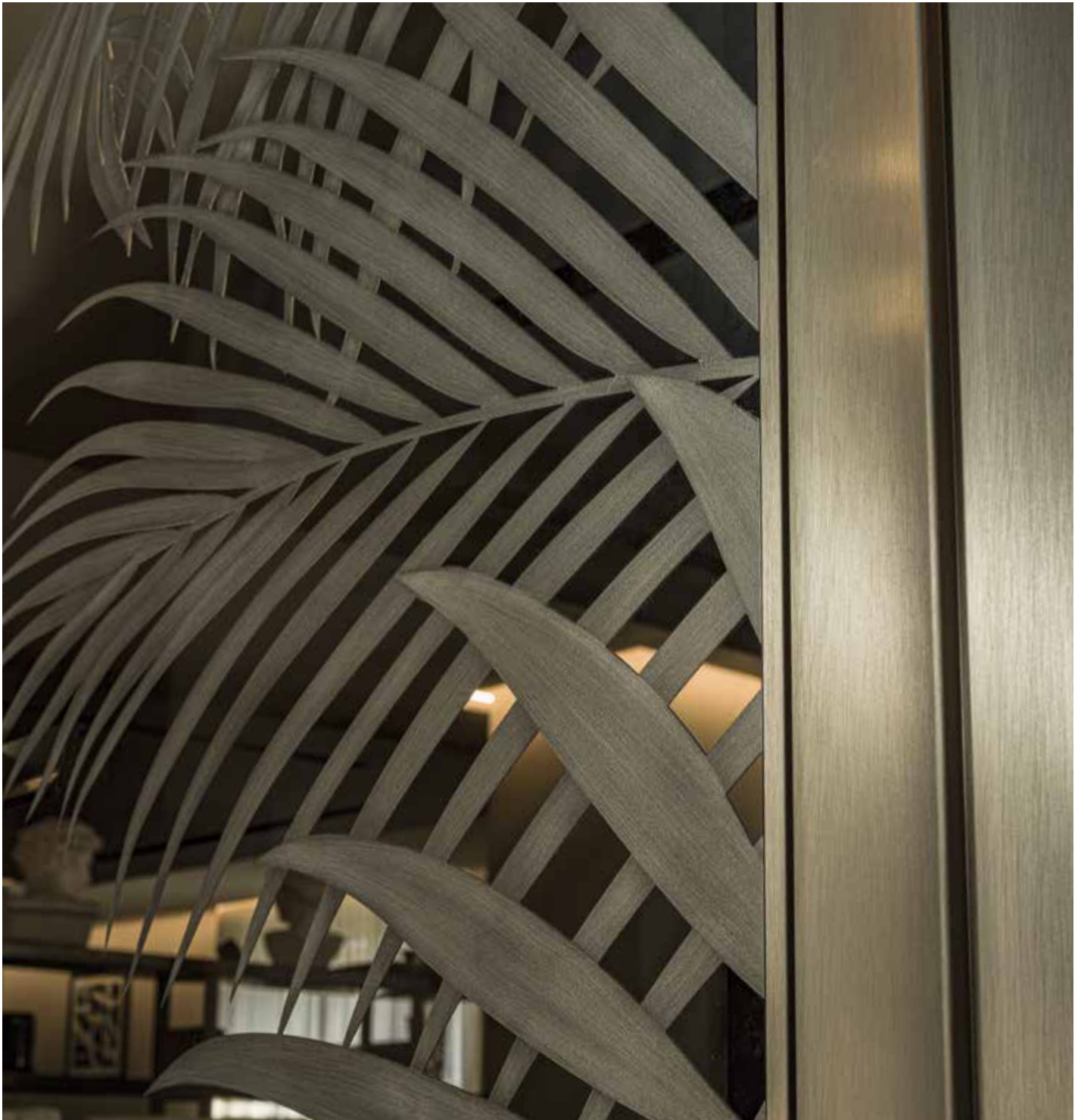

SWING PANEL | IANUS  
JAMB | RELIEF  
PANEL | STOP-SOL BRONZE WITH "PALMA" DECORATION  
STRUCTURE | MATT SATINED BRONZE  
HANDLE INSERT | P.3 TECSUEDE 5120  
ENDLESS BOISERIE | P.3 TECSUEDE 5120

*Land*

*Ianus*

*Forever*

*BeMine*

*Spark*

*Boiserie*



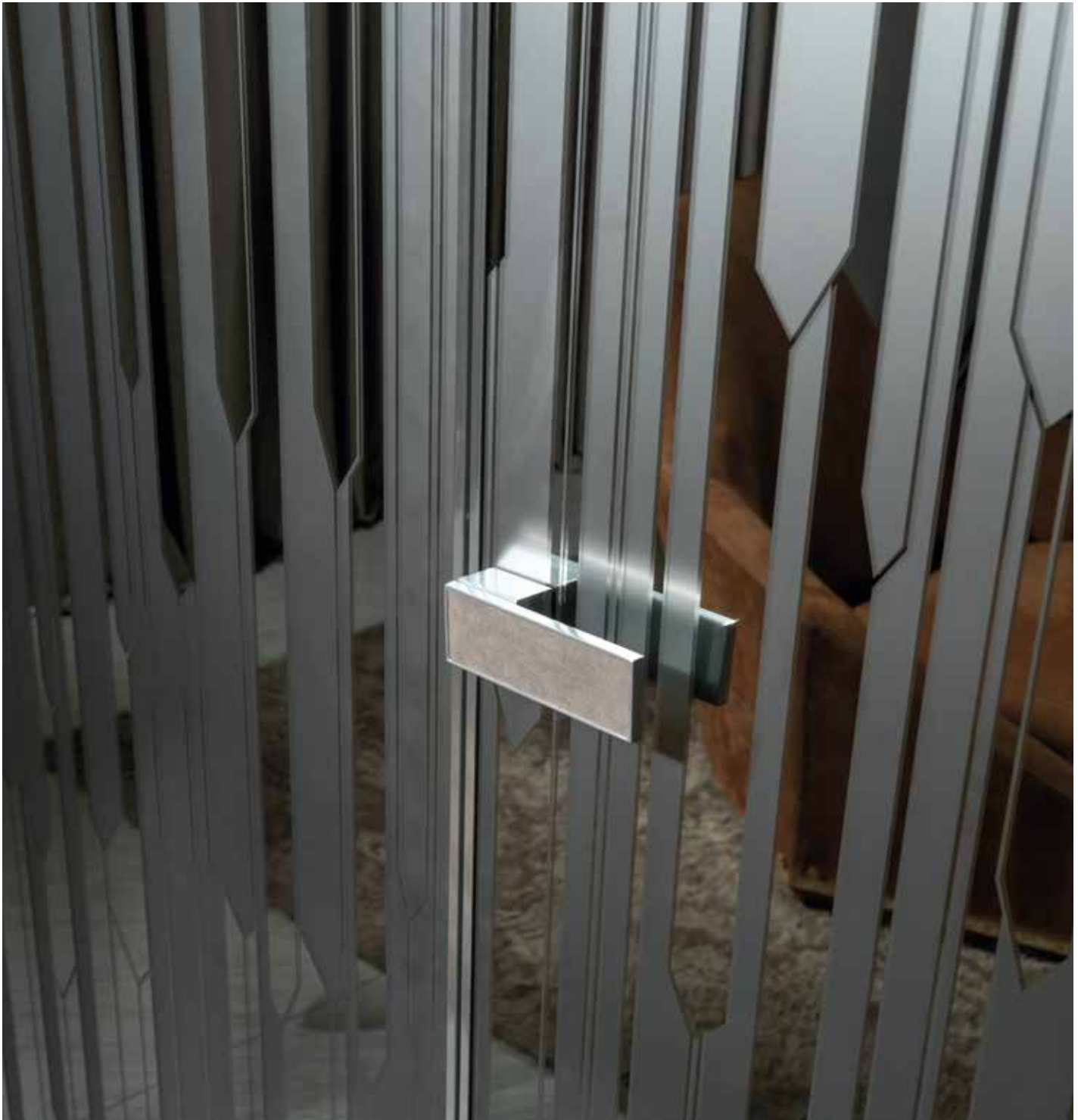

DOUBLE SWING DOOR | IANUS  
JAMB | RELIEF  
STRUCTURE | BRIGHT ALUMINIUM  
PANELS | CRISTAL RAIN SMOKY MIRROR  
HANDLE INSERT | P.3 TECSUEDE 1043

# TECHNICAL NOTES

## *FILOMURO jamb / FREE jamb*

SWING DOOR WITH FILOMURO JAMB



POCKET SLIDING DOOR WITH FREE JAMB







HANDLE WITH WHITE ONYX INSERT



SWING DOOR | IANUS  
JAMB | FILOMURO  
STRUCTURE | BRIGHT DARK BROWN ELECTROCOLOUR  
PANELS | STOP-SOL BRONZE  
HANDLE INSERT | WHITE ONYX





DOUBLE SWING DOORS | IANUS  
JAMB | FILOMURO  
STRUCTURE | BRIGHT ALUMINIUM  
PANELS | GLOSSY LACQUERED TEMPERED CANAPA GLASS  
HANDLE INSERT | P.3 TECSUEDE 3103





SLIDING PANEL | IANUS  
JAMB | FILOMURO  
STRUCTURE | BRIGHT CHAMPAGNE GOLD  
PANELS | P.3 TECSUEDE 5311  
HANDLE INSERT | FRAPPUCCINO MARBLE  
ENDLESS BOISERIE | P.3 TECSUEDE 5311





POCKET SLIDING PANEL | IANUS  
JAMB | FREE  
STRUCTURE | BRIGHT ALUMINIUM  
PANEL | P.3 TECSUEDE 5311  
HANDLE INSERT | AGATHA BLACK MARBLE  
ENDLESS BOISERIE | P.3 TECSUEDE 5311

# TECHNICAL NOTES

## *Bi-directional swing door*

BI-DIRECTIONAL OPENING







BI-DIRECTIONAL SWING DOOR | IANUS  
STRUCTURE | BRIGHT ALUMINIUM  
PANELS | GLOSSY LACQUERED TEMPERED TURTLE DOVE GLASS  
HANDLE INSERT | P.3 TECSUEDE 3103







BI-DIRECTIONAL SWING DOOR | IANUS  
STRUCTURE | BRIGHT ALUMINIUM  
PANEL | P.3 ECO-LEATHER 50  
HANDLE INSERT | P.3 ECO-LEATHER 50  
BOISERIE LAND | BRIGHT ALUMINIUM + P.3 ECO-LEATHER 50





# TECHNICAL NOTES

## *Aluminium enlargement pads on LOTO jamb* **FOR GLOSSY FINISHES**

CM 10 - CM 12,7

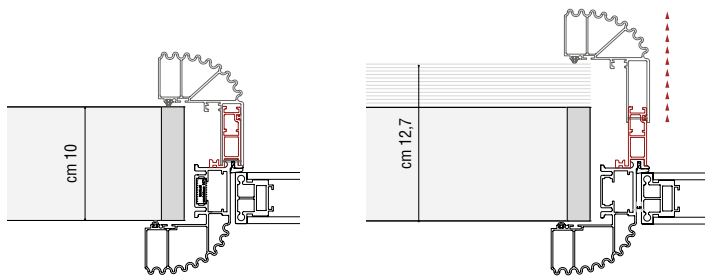

CM 12,8 - CM 17,5

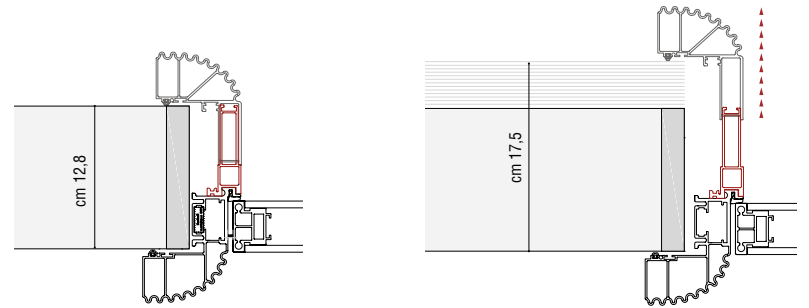

CM 17,6 - CM 20

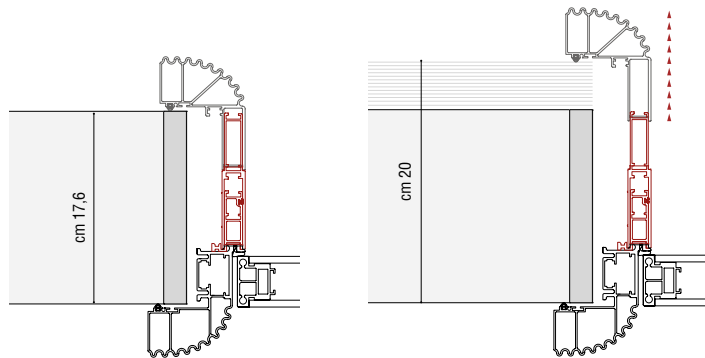

CM 20,1 - CM 24

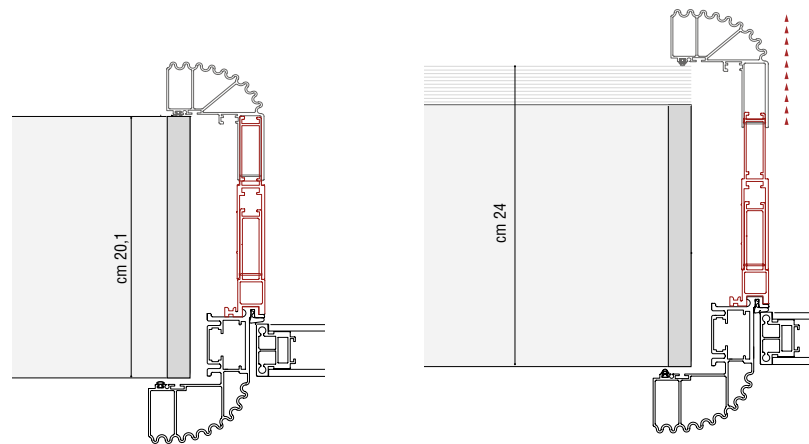

## *Wooden enlargement pads on LOTO jamb* **FOR MATT FINISHES**

CM 10 - ONWARDS

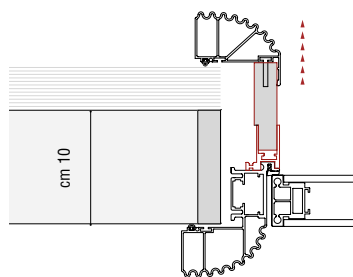

# TECHNICAL NOTES

## *Aluminium enlargement pads on RELIEF jamb*

### FOR GLOSSY FINISHES

CM 10 - CM 12,7

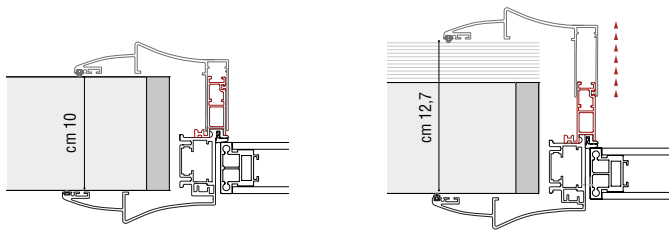

CM 12,8 - CM 17,5

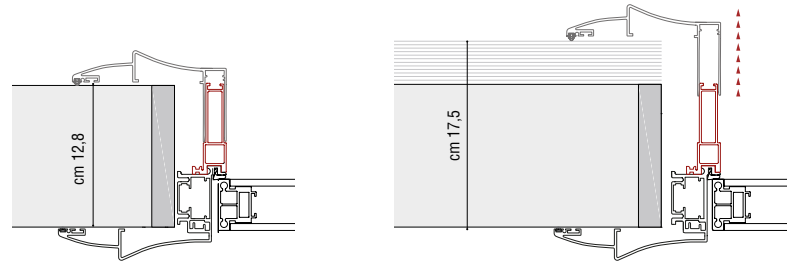

CM 17,6 - CM 20

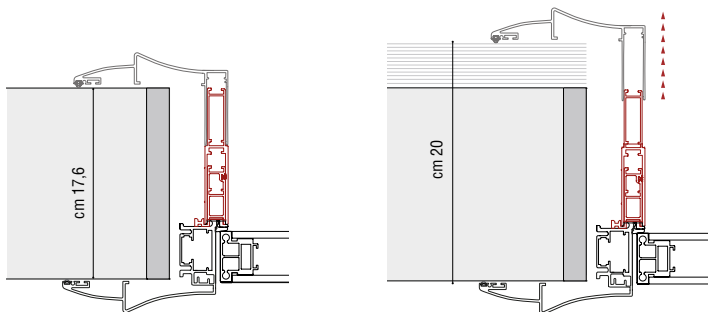

CM 20,1 - CM 24

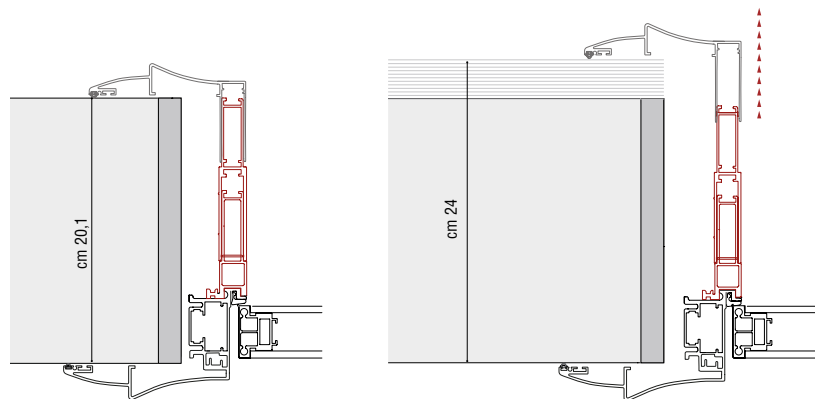

## *Wooden enlargement pads on RELIEF jamb*

### FOR MATT FINISHES

CM 10 - ONWARDS

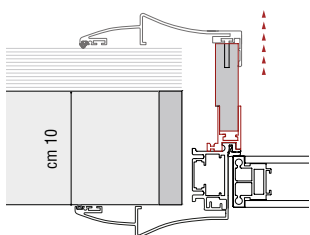

# TECHNICAL NOTES

## *Ianus finishes*

### STRUCTURE AND JAMB

#### Aluminium



MATT SATINED BRONZE    BRIGHT CHAMPAGNE GOLD    BRIGHT DARK BROWN ELECTROCOLOUR    BRIGHT ALUMINIUM    MATT DARK BROWN ELECTROCOLOUR

#### Matt lacquered (LOTO JAMB EXCLUDED)



WHITE    CANAPA    ROPE    TURTLE DOVE    COFFEE    MOKA    PRUN    CEMENT GREY



LEAD GREY    GRANITE    SLATE GREY    NIGHT BLUE    BLACK

### PANEL

#### Reflective glass



STOP-SOL BRONZE    STOP-SOL GREY

#### Stop-sol with Decoration (only for full panel)

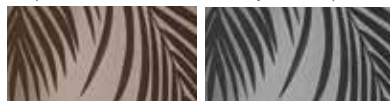

BRONZE STOP-SOL WITH "PALMA" DECORATION    GREY STOP-SOL WITH "PALMA" DECORATION

#### Transparent glass



TEMPERED DARK SMOKY

#### Decorated mirrors



CRISTAL RAIN BRONZE    CRISTAL RAIN SMOKY

#### Mirrors



MIRROR    BRONZE MIRROR    SMOKY MIRROR    FROSTED BRONZE MIRROR    FROSTED SMOKY MIRROR

#### Textured glass



DOVE GREY "ASTRAKAN"    DOVE GREY "BARK"    PEWTER "LIZARD"

#### Cristal Rain" decorated lacquered glass



WHITE    CANAPA    ROPE    TURTLE DOVE    COFFEE    MOKA    PRUNE    CEMENT GREY



LEAD GREY    GRANITE    SLATE GREY    NIGHT BLUE    BLACK

PANEL

*Matt/glossy wood (GLOSSY FINISH ONLY FOR SWING DOOR)*

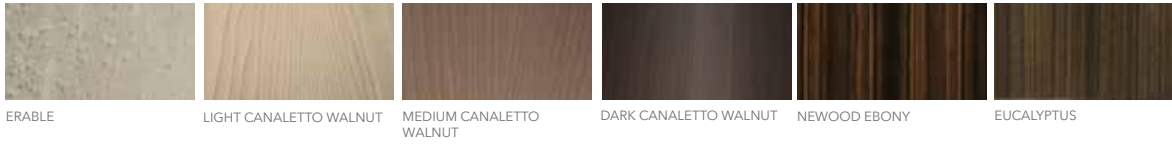

*Matt Slatted wood*

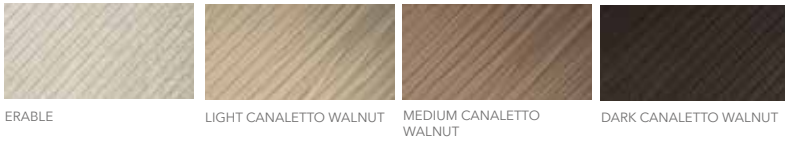

PANEL AND HANDLE INSERT

*Glossy lacquered tempered glass*



*Tecsuede Cat. P3*



*Eco-leather Cat. P3*

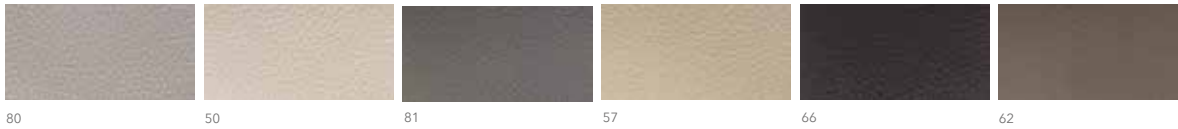

# TECHNICAL NOTES

## *handle*

---

### HANDLE FOR SWING DOOR



Inserts can be in the same finish of the panel or as per the special finishes listed on the right page.

*Gli inserti possono essere nella medesima finitura dell'anta o nelle finiture speciali elencate a destra.*

---

### MAGNETIC LOCK



SIMPLE LOCK



LOCK WITH LATCH



LOCK WITH KEY

---

### HANDLE STRUCTURE FINISH

#### *Aluminium*



MATT SATINED BRONZE



BRIGHT CHAMPAGNE GOLD



BRIGHT DARK BROWN  
ELECTROCOLOUR



BRIGHT ALUMINIUM



MATT DARK BROWN  
ELECTROCOLOUR

#### *Matt lacquered finish*

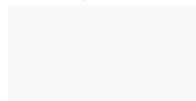

WHITE

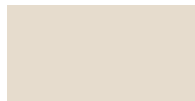

CANAPA



ROPE

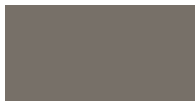

TURTLE DOVE



COFFEE

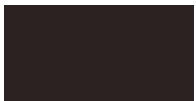

MOKA



PRUN



CEMENT GREY



LEAD GREY



GRANITE



SLATE GREY



NIGHT BLUE



BLACK

---

## SPECIAL HANDLE INSERT

### Onyx and marbles insert



RED ONYX



HONEY ONYX



IVORY ONYX



WHITE ONYX



GREEN ONYX

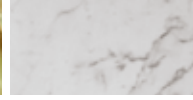

WHITE CARRARA MARBLE



IMPERIAL BROWN MARBLE



BARDIGLIO NUVOLATO MARBLE



VERDE GUATEMALA MARBLE



EMPERADOR DARK MARBLE



SILVER WAVE MARBLE

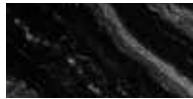

AGATHA BLACK MARBLE



ROSSO LEVANTO MARBLE



DOVER WHITE MARBLE



CALACATTA MARBLE



FRAPPUCCINO MARBLE



FUSION MULTICOLOR  
MARBLE



FUSION LIGHT MARBLE



PORTORO MARBLE



PATAGONIA MARBLE



JULIET PINK QUARTZ



BEOLA

### Hand engraved insert



HAND ENGRAVED  
CAST BRASS



HAND ENGRAVED  
SILVER ALUMINIUM

# TECHNICAL NOTES

## *handle*

---

### HANDLE FOR SLIDING DOOR



Inserts can be in the same finish of the panel or as per the special finishes listed on the right page.

*Gli inserti possono essere nella medesima finitura dell'anta o nelle finiture speciali elencate a destra.*

---

### HANDLE STRUCTURE FINISH

#### *Aluminium*



MATT SATINED BRONZE

BRIGHT CHAMPAGNE GOLD

BRIGHT DARK BROWN  
ELECTROCOLOUR

BRIGHT ALUMINIUM

MATT DARK BROWN  
ELECTROCOLOUR

#### *Matt lacquered finish*



WHITE

CANAPA

ROPE

TURTLE DOVE

COFFEE

MOKA

PRUN

CEMENT GREY



LEAD GREY



GRANITE



SLATE GREY



NIGHT BLUE



BLACK

---

## SPECIAL HANDLE INSERT

### Onyx and marbles insert



RED ONYX



HONEY ONYX



IVORY ONYX



WHITE ONYX



GREEN ONYX



WHITE CARRARA MARBLE



IMPERIAL BROWN MARBLE



BARDIGLIO NUVOLATO MARBLE



VERDE GUATEMALA MARBLE



EMPERADOR DARK MARBLE



SILVER WAVE MARBLE

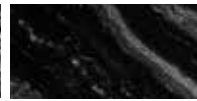

AGATHA BLACK MARBLE



ROSSO LEVANTO MARBLE



DOVER WHITE MARBLE



CALACATTA MARBLE



FRAPPUCCINO MARBLE



FUSION MULTICOLOR  
MARBLE



FUSION LIGHT MARBLE



PORTORO MARBLE



PATAGONIA MARBLE



JULIET PINK QUARTZ



BEOLA

### Hand engraved insert



HAND ENGRAVED  
CAST BRASS



HAND ENGRAVED  
SILVER ALUMINIUM

---

### Satin embroidered insert



# TECHNICAL NOTES

## *Loto handle*

---

### HANDLE FOR SWING DOOR



---

### MAGNETIC LOCK



SIMPLE LOCK



LOCK WITH LATCH



LOCK WITH KEY

---

### HANDLE STRUCTURE FINISH

#### *Aluminium*



MATT SATINED BRONZE



BRIGHT CHAMPAGNE GOLD



BRIGHT DARK BROWN  
ELECTROCOLOUR



BRIGHT ALUMINIUM



MATT DARK BROWN  
ELECTROCOLOUR



# FOREVER

designed by Anna & Enrico Cattaneo | Serie\_343

Forever system è una nuova visione di arredo, capace di trasformare lo spazio, esaltando l'architettura d'interni. Il sistema si veste con finiture innovative e ricercate che impreziosiscono ogni ambiente. Forever system si compone di molteplici elementi integrati tra loro ed è facilmente riconoscibile grazie ai suoi elementi morbidi, che identificano questo sistema, come i raccordi delle pareti, le nicchie decorative e gli stipiti delle porte.

La luce a led, soffusa e delicata, dona atmosfera a tutto l'ambiente e caratterizza le attrezzature a parete, come le mensole e i vani. Questi ultimi hanno dimensioni e funzioni differenti: da piccole librerie fino ad ampie consolle o scrittoi. Forever system può anche spogliarsi della sua morbidezza e trasformarsi in una boiserie rigorosa, con porte a battente complanari, sia a tirare che a spingere.

*Forever system is a new furnishing vision able to transform the space, enhancing the architectural interiors. It is dressed in innovative and refined finishes which embellish every space.*

*Forever system is made up of several integrated elements and it is easily distinctive due to its supple elements like the wall joints, the decorative niche and the doors' jambs.*

*The LED light, soft and delicate, gives a special atmosphere to the surrounding environment and defines the wall elements like shelves and niches. The latter have different dimensions and functionalities: from small bookcase to wider console or writing desk. Forever system can divest itself from its smoothness and become a more rigorous wall cladding with flush hinged doors, both push or pull.*

*Forever system - это новое видение обстановки, преобразующей пространство, подчеркивая особенности архитектурных решений интерьеров. Система используется с инновационными изысканными видами отделки, повышающими ценность любого помещения. Forever system состоит из многочисленных интегрированных между собой компонентов и легко узнаваема благодаря характеризующим ее мягким элементам: соединителям стен, декоративным нишам и дверным косякам.*

*Мягкий приглушенный свет от светодиодной подсветки создает атмосферность во всем помещении и выделяет настенные элементы: полки и ниши. Ниши имеют разные размеры и выполняют различные функции: от маленьких книжных шкафов до больших консолей или письменных столов. Forever system может быть также представлена без мягкой отделки, превращаясь в стеновую панель как таковую, с дверями с компланарными створками, открывающимися на и от себя.*

Forever system 是家装的新视野，能够改变空间，提升室内建筑。该系统凭其创新而精巧的面饰，轻松驾驭任何环境。Forever system 由多种元素相互集合而成，其中最具标志性的便是柔软元素，例如墙壁连接处、装饰壁龛和门框。

柔和精致的 LED 灯光打造整体氛围并刻画壁挂设备，如隔板 and 隔间。后者有多种尺寸和功能可供选择：从小书柜到大控制台或书桌。Forever system 也可从柔软转化成硬朗的墙面镶板，配以可推拉的共面铰链门。







SWING DOOR | FOREVER  
ROUND JAMB | P.3 TECSUEDE 5105  
STRUCTURE AND PROFILE | MATT SATINED BRONZE  
PANEL AND HANDLE INSERT | P.3 TECSUEDE 5105  
BOISERIE FOREVER | P.3 TECSUEDE 5105 + GLOSSY ERABLE





# TECHNICAL NOTES

## *FOREVER system*

SYSTEM ELEMENTS



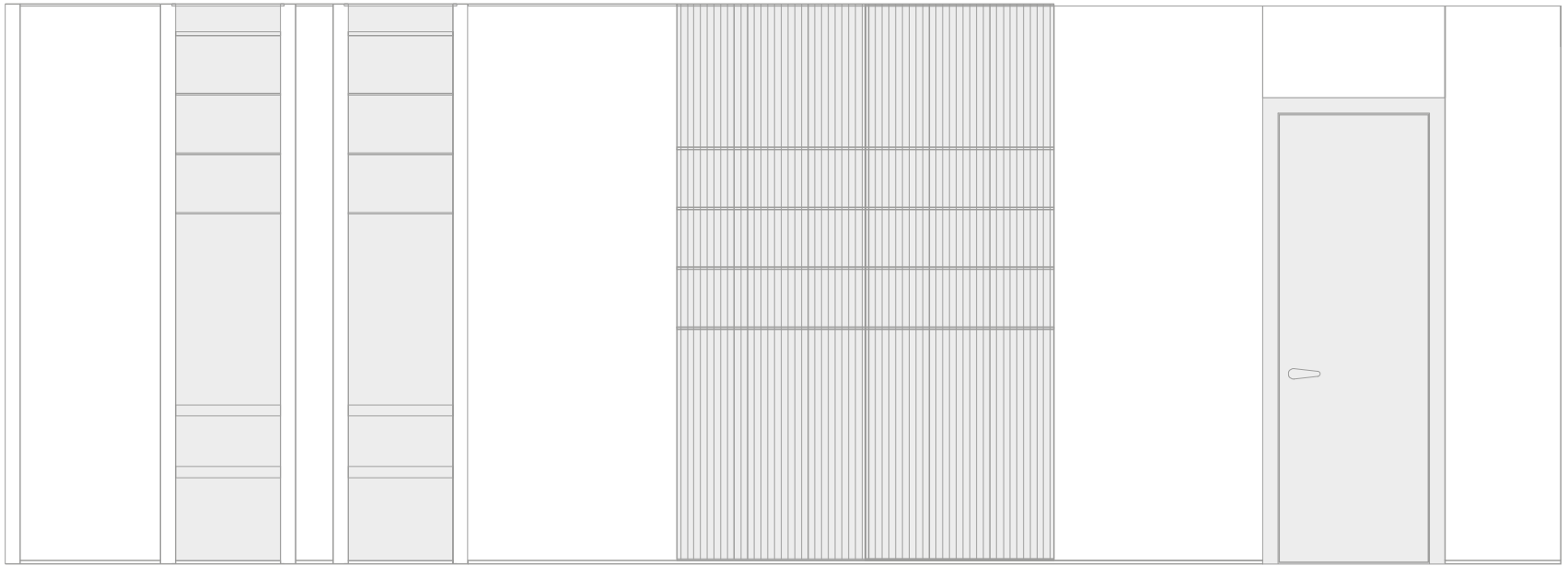

NICHES

WALL PANELS  
WITH SHELVES

WALL  
PANELS

DOOR



# TECHNICAL NOTES

## *Swing doors*

DOOR SECTION



OPENING



PULL



FLUSH PUSH

DESIGN OPTIONS



FULL PANEL

PANEL WITH  
ALUMINIUM PROFILE

---

SWING DOOR WITH BOISERIE



ROUND JAMB



FILOMURO JAMB

---

SWING DOOR WITHOUT BOISERIE



LESS JAMB



SWING DOOR | FOREVER  
ROUND JAMB | P.3 TECSUEDE 5604  
STRUCTURE | MATT SATINED BRONZE  
PANEL AND HANDLE INSERT | P.3 TECSUEDE 5604  
BOISERIE FOREVER | P.3 TECSUEDE 5604

# FOREVER *flush*

AESTHETIC CONTINUITY BETWEEN  
DOOR AND BOISERIE IS GUARANTEED  
BY THE POSSIBILITY OF FLUSH  
OPENING, PULL OR PUSH.

La continuità estetica tra porta e boiserie è garantita dalla possibilità di avere un'apertura perfettamente complanare: porta disponibile nella versione tirare o spingere.

Эстетическая преемственность между дверью и буазери обеспечивается возможностью полностью компланарного открытия: дверь в варианте открытие на или от себя.

完美的共面开口保证了门和墙面镶板之间美学的连续性。门可用版本 拉或推。

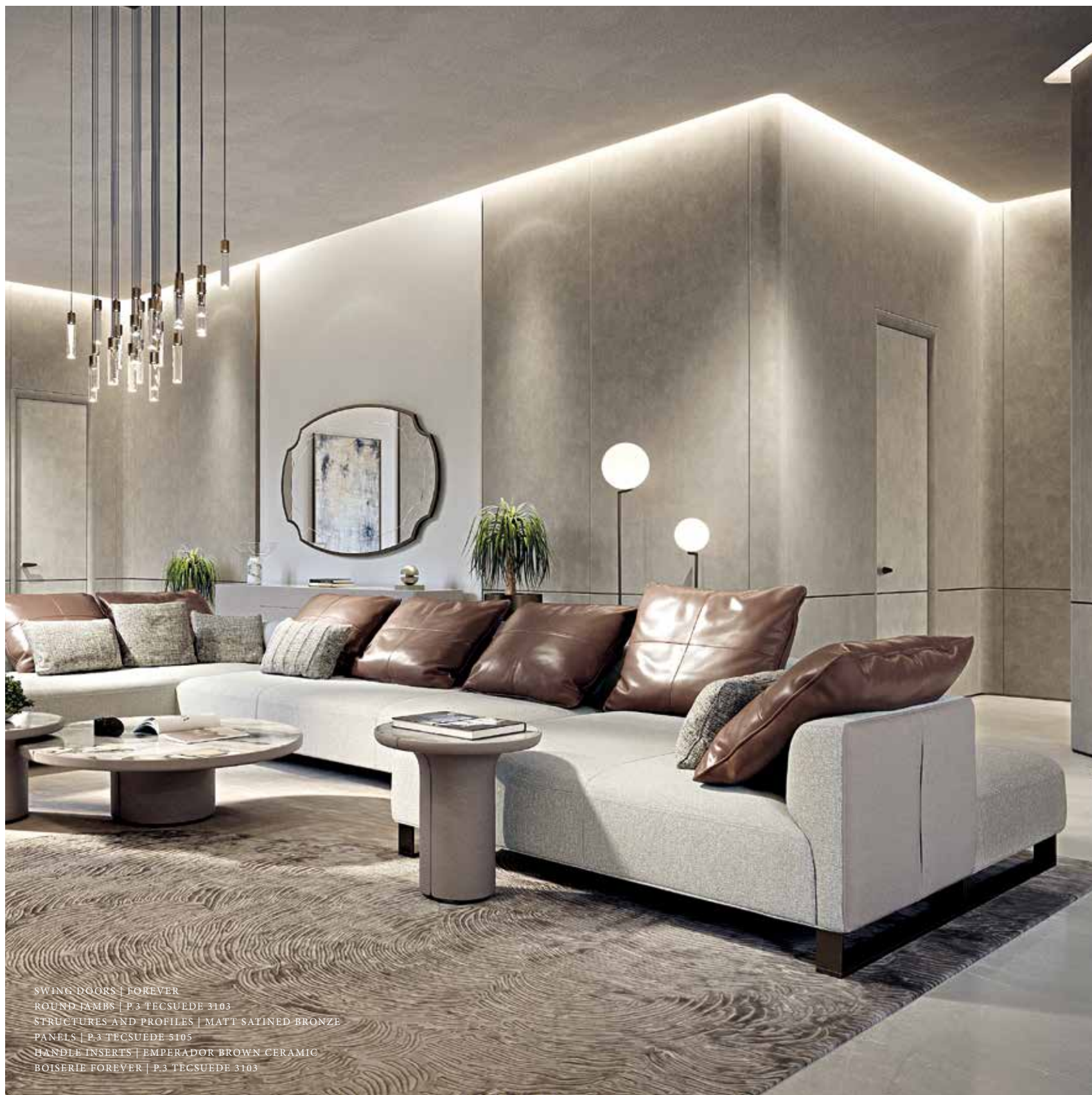

SWING DOORS | FOREVER  
ROUND JAMBS | P.3 TECSUEDE 3103  
STRUCTURES AND PROFILES | MATT SATINED BRONZE  
PANELS | P.3 TECSUEDE 5105  
HANDLE INSERTS | EMPERADOR BROWN CERAMIC  
BOISERIE FOREVER | P.3 TECSUEDE 3103

# FOREVER *boiserie*

A BOISERIE SYSTEM COMPLETE WITH  
FITTED WALLS AND ILLUMINATED  
NICHE. MAXIMUM VERSATILITY OF  
SHAPE AND MATERIAL DEFINES A NEW  
AESTHETIC CODE.

*Forever*

Un sistema di boiserie corredato da pareti attrezzate e nicchie illuminate. La massima versatilità di forme e materiali definisce un nuovo codice estetico.

Система буазери с оснащенными стенками и нишами с подсветкой. Максимальная универсальность форм и материалов определяет новый эстетический кодекс.

墙面镶板系统配有设施齐全的墙壁和带照明的壁龛。形状和材料的多功能性定义了一种新的美学规范。

# TECHNICAL NOTES

## *Flush door with BOISERIE*

SWING DOOR WITH ROUND JAMB

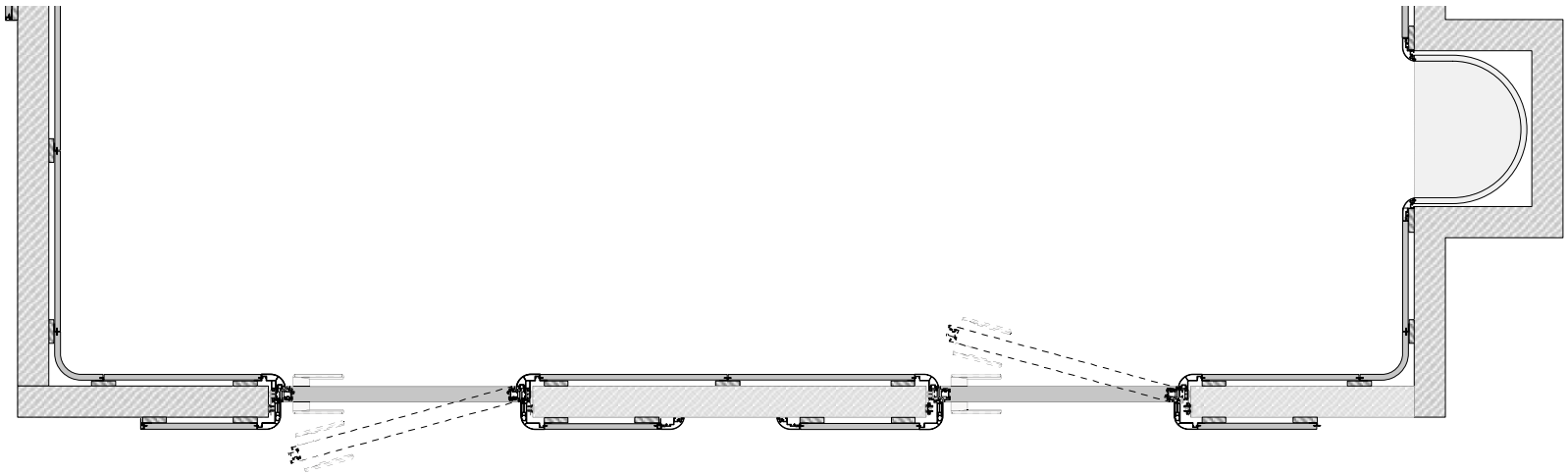

SWING DOOR WITH FILOMURO JAMB

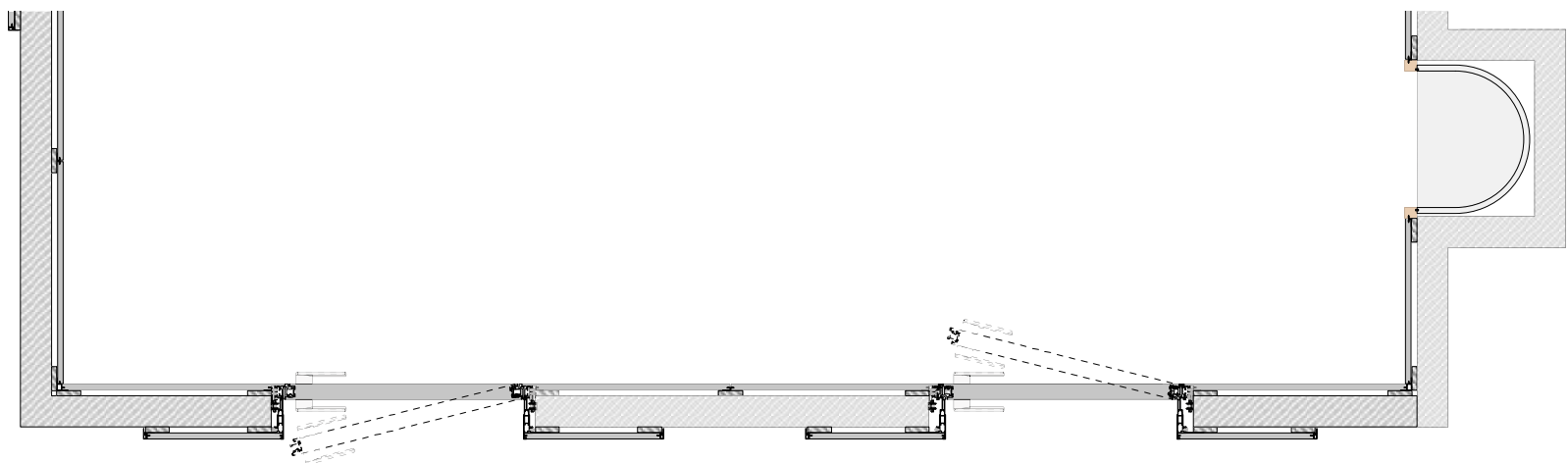



*Forever*



# TECHNICAL NOTES

## *Swing door with boiserie - ROUND jamb*

SWING DOOR WITH ROUND JAMB - PULL VERSION



SWING DOOR WITH ROUND JAMB - PUSH VERSION







SWING DOORS | FOREVER  
ROUND JAMBS | P.3 TECSUEDE 5311  
STRUCTURES AND PROFILES | MATT CHAMPAGNE  
PANELS | P.3 TECSUEDE 5604  
HANDLE INSERTS | P.3 TECSUEDE 5311  
BOISERIE FOREVER | P.3 TECSUEDE 5311

WOODEN FINISH



ALUMINIUM FINISH



COVERED



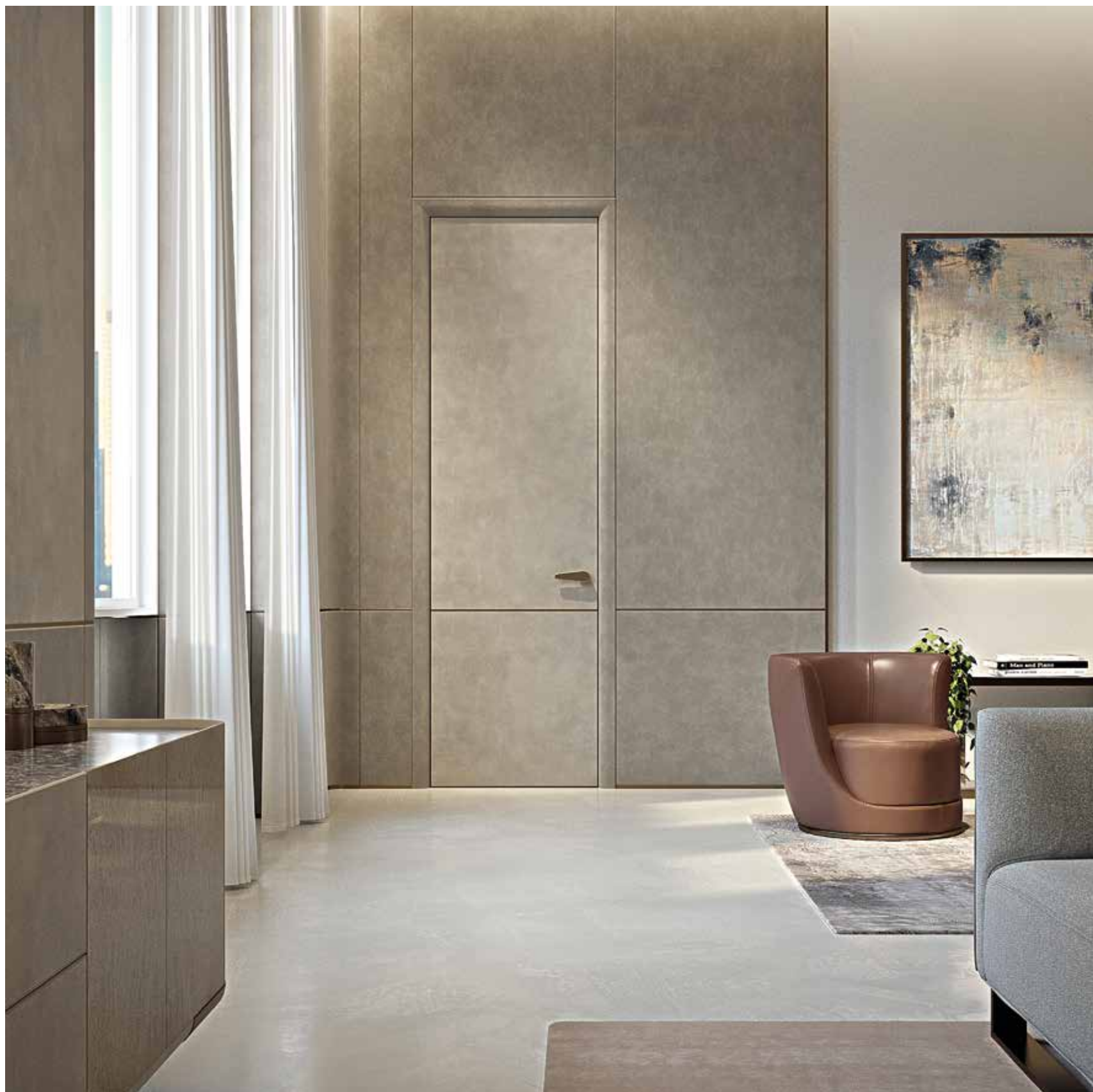

# CLADDING

A SELECTION OF MATERIALS  
OFFERING MAXIMUM VERSATILITY.  
THE CHOSEN SHADES PERFECTLY  
MATCH WITH ALL THE EXCLUSIVE  
FINISHES OF THE COLLECTION.

Forever

ECO-LEATHER



TECSUEDE

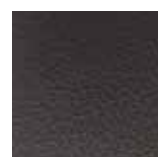
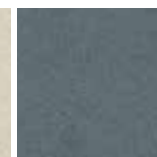
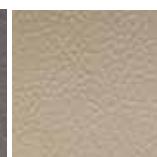
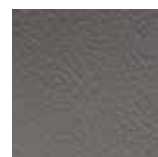
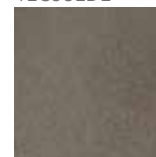

Selezione di materiali dalla massima versatilità. I toni scelti si abbinano perfettamente con tutti i materiali esclusivi della collezione.

Подборка в высшей степени универсальных материалов. Подобранные оттенки идеально сочетаются со всеми эксклюзивными материалами, выбранными для этой коллекции.

选用多功能材料。所选色调与为该系列精选的所有独家材料完美呼应。



SWING DOOR | FOREVER  
ROUND JAMB | GLOSSY EUCALYPTUS  
PROFILE | MATT CHAMPAGNE  
PANEL AND HANDLE INSERT | GLOSSY EUCALYPTUS  
BOISERIE FOREVER | GLOSSY EUCALYPTUS + P.3 TECSUEDE 5604

# WOOD

THE SELECTION OF WOODS  
DESIGNED TO ALLOW MAXIMUM  
FREEDOM OF EXPRESSION MAKES  
EACH PROJECT UNIQUE.

La selezione di essenze studiata per consentire la massima libertà espressiva rende unico ogni progetto.

благодаря подбору различных пород дерева для обеспечения максимальной свободы выражения обеспечивается уникальность каждого проекта.

选取精品以保证最大程度的表达自由，使每个项目都独一无二。

ERABLE



LIGHT CANALETTO WALNUT



EUCALYPTUS

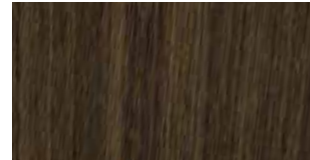

MEDIUM CANALETTO WALNUT



NEWOOD EBONY



DARK CANALETTO WALNUT



# TECHNICAL NOTES

## *Swing door with boiserie - FILOMURO jamb*

---

SWING DOOR AND BOISERIE WITH FILOMURO JAMB - PULL VERSION



---

SWING DOOR AND BOISERIE WITH FILOMURO JAMB - PUSH VERSION



SWING DOOR | FOREVER  
FILOMURO JAMB | MATT CHAMPAGNE  
PROFILE | MATT CHAMPAGNE  
PANEL | GLOSSY ERABLE + P.3 TECSUEDE 5120  
HANDLE INSERT | GLOSSY ERABLE  
BOISERIE FOREVER | GLOSSY ERABLE + P.3 TECSUEDE 5120



*Forever*



SWING DOOR | FOREVER  
FILOMURO JAMB | MATT SATINED BRONZE  
PROFILE | MATT SATINED BRONZE  
PANEL AND HANDLE INSERT | MATT EUCALYPTUS  
BOISERIE FOREVER | MATT EUCALYPTUS





SWING DOOR | FOREVER  
FILOMURO JAMB | MATT CHAMPAGNE  
PANEL AND HANDLE INSERT | DIAMOND CREAM CERAMIC  
BOISERIE FOREVER | DIAMOND CREAM CERAMIC + P.3 TECSUEDE 5120







SWING DOOR | FOREVER  
FUILOMURO JAMB | MATT CHAMPAGNE  
PANEL AND HANDLE INSERT | DIAMOND CREAM CERAMIC  
BOISERIE FOREVER | DIAMOND CREAM CERAMIC

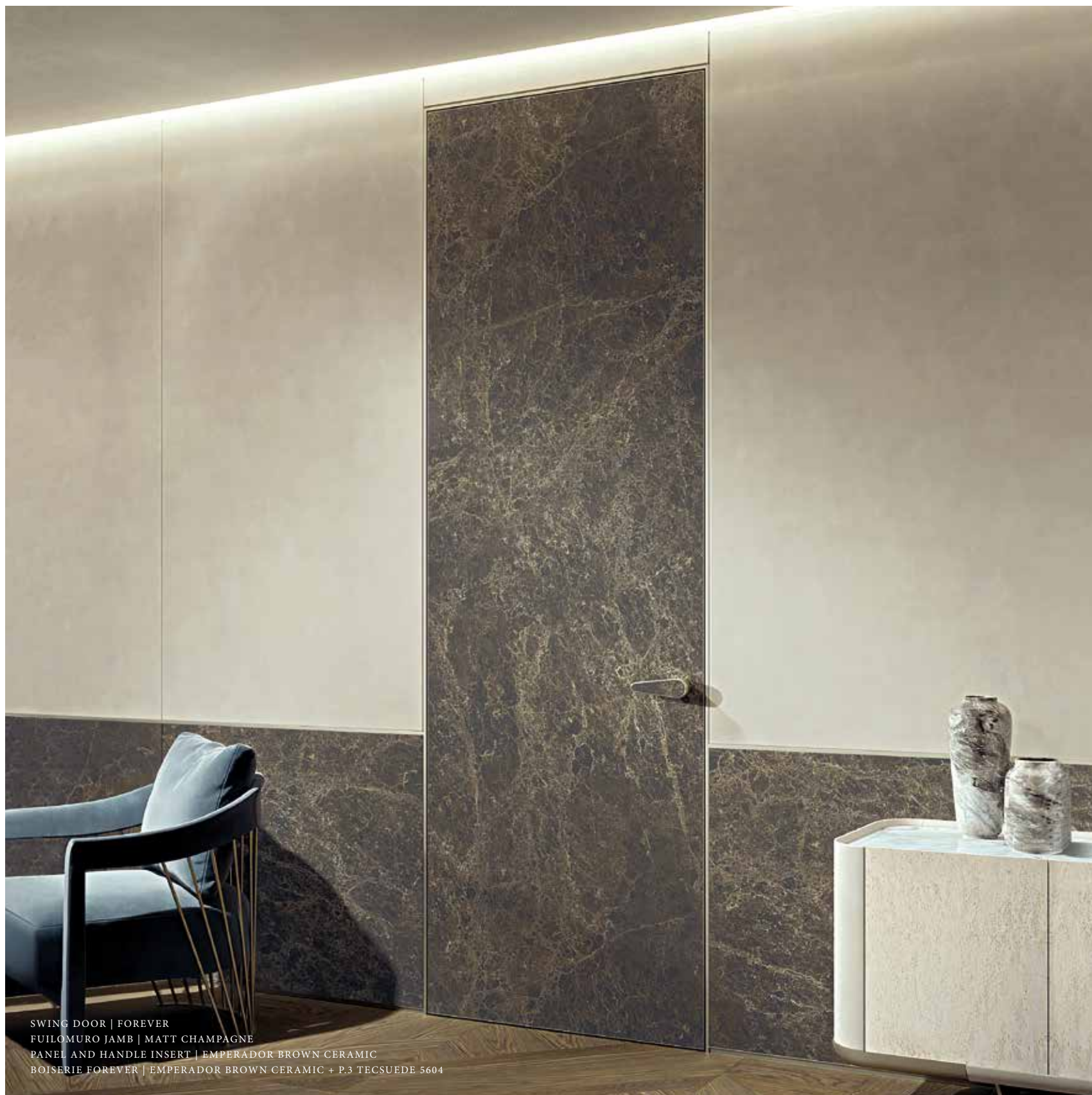

SWING DOOR | FOREVER  
FUILOMURO JAMB | MATT CHAMPAGNE  
PANEL AND HANDLE INSERT | EMPERADOR BROWN CERAMIC  
BOISERIE FOREVER | EMPERADOR BROWN CERAMIC + P.3 TECSUEDE 5604

# CERAMICS

CERAMIC SLAB COVERINGS LEND  
UNIQUE VALUE TO ANY ROOM.  
AVAILABLE IN THREE VERSIONS,  
DEFINES A NEW AESTHETIC SCHEME.

Forever

La lastra di ceramica conferisce un valore unico agli ambienti che riveste.  
Il materiale, proposto in tre declinazioni, definisce un nuovo schema estetico.

Керамическая плита придает уникальность и повышает ценность помещений.  
Материал, предлагаемый в трех вариантах, определяет новый эстетический замысел.

陶瓷板赋予它所覆盖的环境独特的价值。  
该材料以三种可变的形式定义了一种新的美学方案。

DIAMOND CREAM

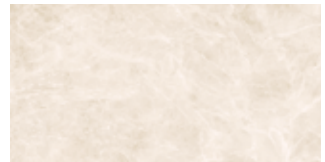

EMPERADOR BROWN



GREY



# TECHNICAL NOTES

## *Swing door with LESS jamb*

SWING DOOR WITH LESS JAMB - PUSH VERSION



SWING DOOR WITH LESS JAMB - PULL VERSION



SWING DOOR | FOREVER  
LESS JAMB | MATT SATINED BRONZE  
PANEL | STOP-SOL BRONZE  
HANDLE INSERT | EMPERADOR BROWN CERAMIC



*Forever*



SWING DOOR | FOREVER  
LESS JAMB | MATT LACQUERED CANAPA  
PANEL | GLOSSY LACQUERED CANAPA WAVY GLASS  
HANDLE INSERT | GLOSSY LACQUERED CANAPA GLASS



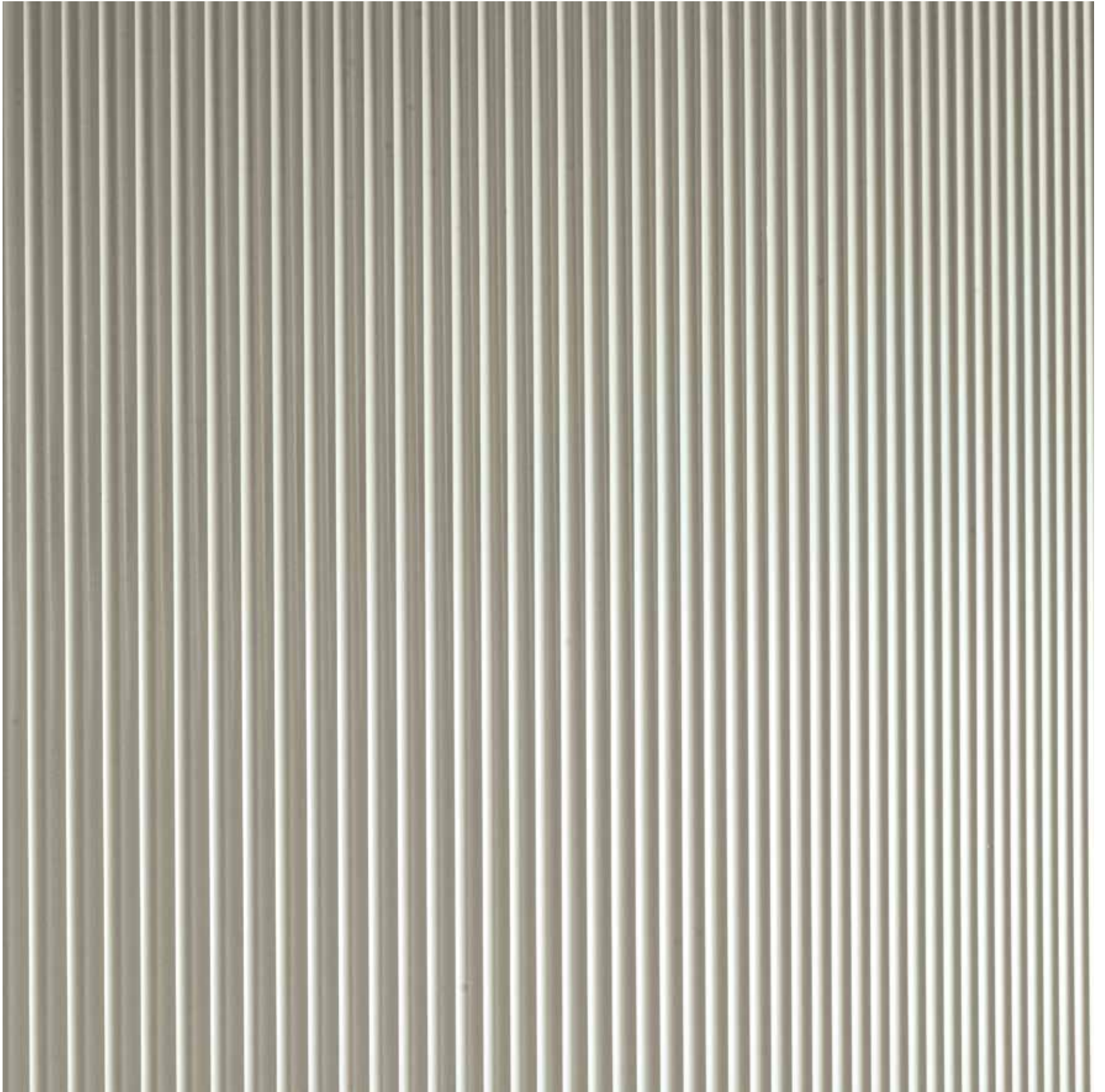

# WAVY GLASS

ITS WAVY FINISH MOULDS SURFACES WITH EFFECTS OF LIGHT AND SHADOW. AVAILABLE IN THE GLOSSY LACQUERED COLOURS FROM THE SAMPLE COLLECTION.

GLOSSY LACQUERED WAVY GLASS



La sua lavorazione ondulata plasma le superfici con giochi di luci e ombre. Disponibile nelle cromie laccate lucide a campionario.

Волнистая обработка поверхности создает интересную игру света и тени. Предлагается с глянцевой лакированной отделкой оттенков по образцам.

其波浪形的工艺通过光影的变化塑造表面。光面漆颜色可依样本挑选。

PUSH VERSION / PULL VERSION





SWING DOOR | FOREVER  
LESS JAMB | MATT SATINED BRONZE  
PANEL | STOP-SOL BRONZE  
HANDLE INSERT | EMPERADOR BROWN CERAMIC

*Forever*



FOREVER SYSTEM  
IS A NEW FURNISHING  
VISION ABLE TO  
TRANSFORM THE SPACE,  
ENHANCING THE  
ARCHITECTURAL  
INTERIORS.

# TECHNICAL NOTES

## *Enlargement pads on ROUND jamb*

CM 10,5 - CM 14,5

CM 10,5 - ONWARDS (WOODEN ENLARGEMENT PAD)

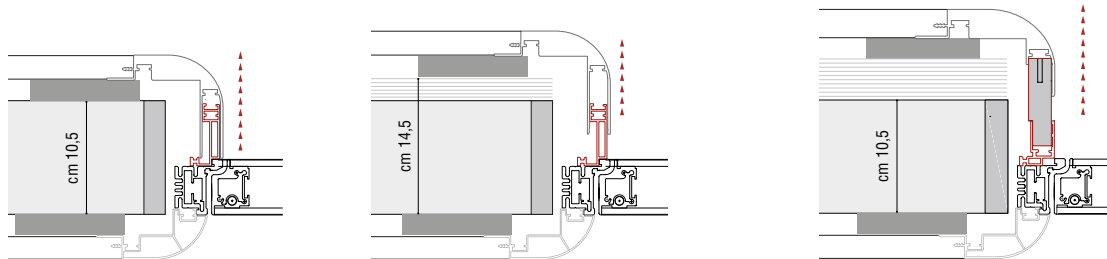

# TECHNICAL NOTES

## *Enlargement pads on LESS jamb*

CM 10,5 - CM 14,5

CM 10,5 - ONWARDS (WOODEN ENLARGEMENT PAD)

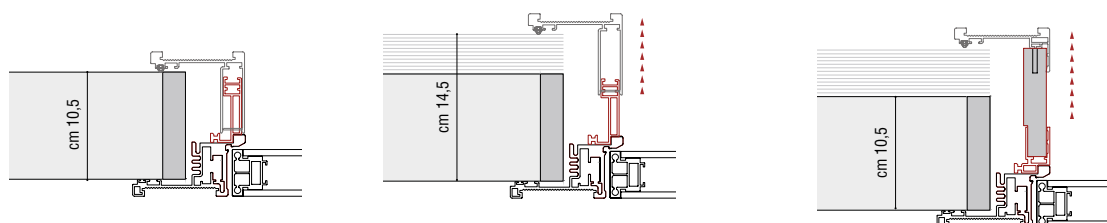

# TECHNICAL NOTES

## *Enlargement pads on FILOMURO jamb*

CM 10,5 - ONWARDS (WOODEN ENLARGEMENT PAD)

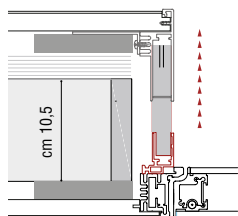

# TECHNICAL NOTES

## *Forever finishes*

---

### STRUCTURE AND JAMB

#### *Aluminio verniciato opaco*



CHAMPAGNE

BRONZE

MOKA

#### *Matt lacquered*



WHITE

CANAPA

ROPE

TURTLE DOVE

COFFEE

MOKA

PRUN

CEMENT GREY



LEAD GREY

GRANITE

SLATE GREY

NIGHT BLUE

BLACK

---

### ROUND JAMB, PANEL AND HANDLE INSERT

#### *Tecsuede Cat. P3*



5311

1043

5120

3103

5105

5604

1012

5119

#### *Eco-leather Cat. P3*



80

50

81

57

66

62

#### *Matt/glossy wood*

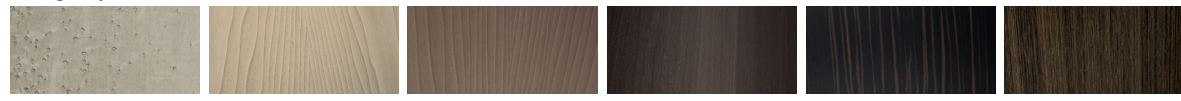

ERABLE

LIGHT CANALETTO  
WALNUT

MEDIUM CANALETTO  
WALNUT

DARK CANALETTO  
WALNUT

NEWOOD EBONY

EUCALYPTUS

---

PANEL AND HANDLE INSERT

*Glossy lacquered tempered glass*



WHITE CANAPA ROPE TURTLE DOVE COFFEE MOKA PRUN CEMENT GREY



LEAD GREY GRANITE SLATE GREY NIGHT BLUE BLACK

*Ceramics*

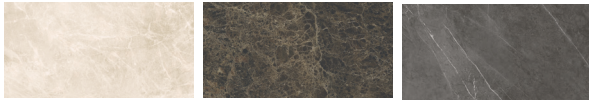

DIAMOND CREAM EMPERADOR BROWN GREY

---

PANEL

*Reflective glass*



BRONZE STOP-SOL GREY STOP-SOL

*Frosted glass*



FROSTED NEUTRAL

*Glossy lacquered wavy glass*

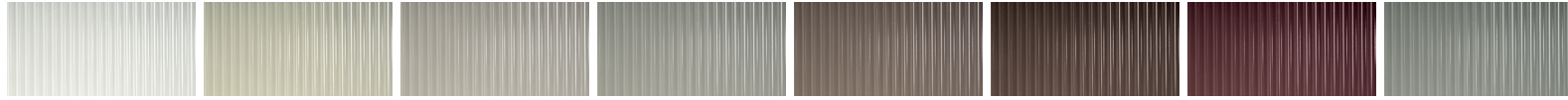

WHITE CANAPA ROPE TURTLE DOVE COFFEE MOKA PRUN CEMENT GREY



LEAD GREY GRANITE SLATE GREY NIGHT BLUE BLACK

# TECHNICAL NOTES

## *handle*

---

### HANDLE FOR SWING DOOR



Inserts can be in the same finish of the panel or as per the special finishes listed on the previous page.

*Gli inserti possono essere nella medesima finitura dell'anta o nei materiali elencanti nella precedente pagina.*

---

### MAGNETIC LOCK



SIMPLE LOCK



LOCK WITH LATCH



LOCK WITH KEY

---

### HANDLE STRUCTURE FINISH

#### *Matt painted aluminium*



CHAMPAGNE

BRONZE

MOKA

#### *Matt lacquered aluminium*

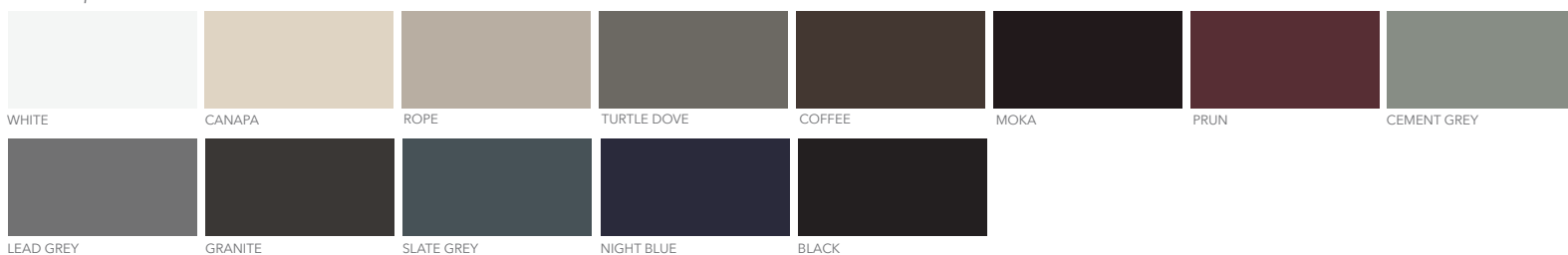

WHITE

CANAPA

ROPE

TURTLE DOVE

COFFEE

MOKA

PRUN

CEMENT GREY

LEAD GREY

GRANITE

SLATE GREY

NIGHT BLUE

BLACK



# BE MINE

designed by ALI | Serie\_338

BeMine vuole essere la sintesi del Know How produttivo dell'azienda per creare un oggetto dalle infinite combinazioni estetiche e realizza l'integrazione totale fra porta e pareti: una sintesi sempre più esclusiva fra elementi d'arredo e architettura d'interni. La porta è oggetto di design, nasce per dare corpo alla prima impressione di un ambiente: originalità, unicità, personalizzazione. Alluminio, legno e pelle, grazie alla loro armoniosa intersecazione con altri materiali innovativi, consentono a BeMine una personalizzazione BeSpoke "Su Misura" unica nel suo genere.

Porte che interpretano lo spazio d'ingresso come esperienza da rendere memorabile, un sottile profilo in alluminio disegna il contorno di una superficie pura che vive di riflessi e della forza dei colori. Caratterizzata dalle finiture esclusive della collezione Longhi e dall'introduzione di una nuova materia: il Grès Marble, una preziosa ceramica resinata e smaltata effetto marmo.

Pura superficie che introduce un ulteriore elemento di caratterizzazione estetica grazie allo stipite con inserto.

*BeMine is the demonstration of the company's production know-how in creating an object that can be arranged in infinite aesthetic combinations. It creates total integration of doors with walls: an increasingly exclusive relationship between furnishings and interior architecture. The door is a design object, and was created to provide the first impression of a room: originality, uniqueness and customisation. Aluminium, wood and leather, through a harmonious interaction with other innovative materials, allow BeMine to become a fully customised option that is one of a kind.*

*Doors that interpret an entry way as an experience to remember, a thin aluminium profile defines the edge of a pure surface that comes alive through vibrant reflections and the strength of colour. Characterised by Longhi's exclusive finishes and a new material, Grès Marble, a precious ceramic finishe with resin and enamel to achieve a marbled effect.*

*Pure surfaces that introduce an additional characteristic aesthetic element with a jamb that has an insert.*

*BeMine хочет быть синтезом производственного ноу-хау компании для создания предмета с бесконечными эстетическими сочетаниями и полного объединения двери и стен: синтезом, все более эксклюзивным, между элементами оформления и архитектурой интерьера. Дверь - это дизайнерский предмет, который рождается для того, чтобы воплотить первое впечатление от помещения: оригинальность, уникальность, индивидуальность. Алюминий, дерево и кожа благодаря гармоничному переплетению с другими инновационными материалами обеспечивают BeMine персонализацию BeSpoke "по мерке", единственную в своем роде.*

*Двери, интерпретирующие входное пространство как ощущение, которое должно запомниться. Тонкий алюминиевый профиль очерчивает контуры чистой поверхности, подчеркиваемой отблесками и силой цветов. Серия характеризуется эксклюзивными отделками Longhi и введением нового материала - Grès Marble, - ценной керамики, пропитанной смолой и покрытой глазурью с эффектом мрамора.*

*Чистая поверхность, которая вносит дополнительный элемент в эстетику благодаря дверной коробке со вставкой.*

BeMine期望成为企业生产技术诀窍的精髓，以创造一种具备无限美感组合的物品，实现门和墙壁完全整合的目标：是一种介于室内建筑与家具元素之间更专属的精髓。门，是需要设计的物品，是为了赋予环境第一印象而诞生：原创、独特、个性化。铝材、木材和皮料，由于它们与其他创新材料的和谐交会，允许了BeMine个性化「量身定制」BeSpoke，是同类产品独一无二的。

门，诠释着入口空间，犹如给予一种令人难忘的经验，纤细的铝边框，为纯净的表面定出轮廓，凸显其反射与色彩的力度。以Longhi系列的独特面饰与所采用的全新材质展现独特：大理石纹路炻瓷，是一种展现大理石效果的珍贵树脂和珐琅陶瓷。

纯净的表面，由于带嵌饰的门框，增添了另一个美感特色的元素。



SWING PANEL | BEMINE  
JAMB | BEMINE  
STRUCTURE | MATT SATINED BRONZE  
PANEL | STOP-SOL BRONZE  
HANDLE INSERT | SILVER WAVE MARBLE

# TECHNICAL NOTES

## *Swing doors*

DOOR SECTION



OPENING



STANDARD

DESIGN OPTION



Max cm 270.7

PANEL WITH  
ALUMINIUM PROFILES

---

SINGLE SWING DOOR



BEMINE JAMB WITH INSERT



BEMINE JAMB WITHOUT INSERT



FILOMURO JAMB

---

DOUBLE SWING DOOR



BEMINE JAMB WITH INSERT



BEMINE JAMB WITHOUT INSERT



FILOMURO JAMB



# BEMINE *jamb*

ELEGANCE AND REFINEMENT  
CHARACTERISE BEMINE JAMB,  
AVAILABLE WITH AND  
WITHOUT INSERT.

Eleganza e raffinatezza caratterizzano lo stipite Bemine, disponibile nella versione con e senza inserto.

Элегантность и изысканность отличают косяк "Bemine", предлагаемый в варианте с и без вставки.

Bemine 门框的特点是优雅精致，可选带或不带嵌饰的版本。

# TECHNICAL NOTES

## *Swing door*

---

SWING DOOR WITH BEMINE JAMB



---

SWING DOOR WITH FILOMURO JAMB







SWING DOOR | BEMINE  
JAMB | BEMINE WITH P.3 TECSUEDE 5119 INSERT  
STRUCTURE | BRIGHT CHAMPAGNE GOLD  
PANELS | P.3 TECSUEDE 5119  
HANDLE INSERT | SILVER WAVE MARBLE



*BeMine*

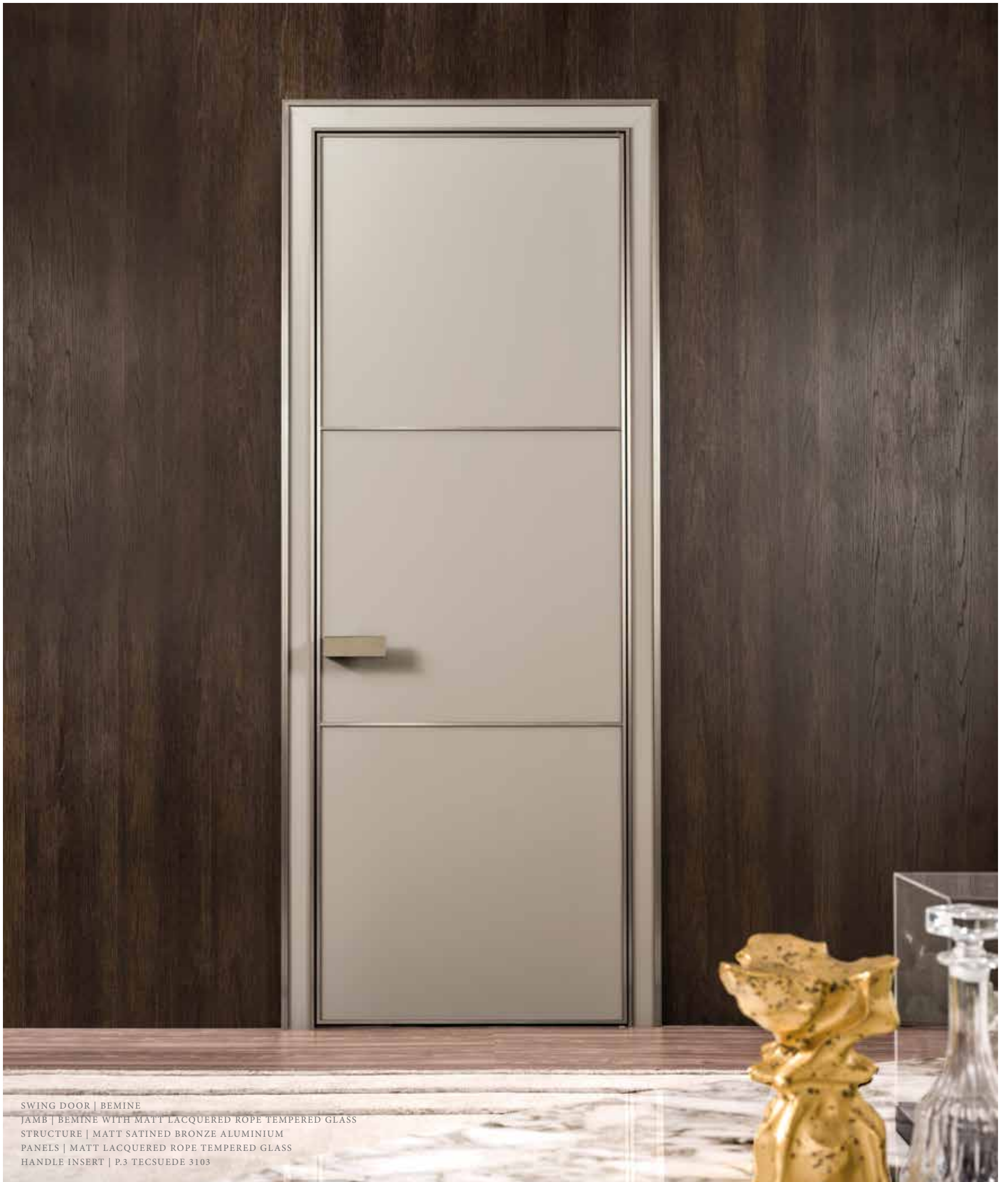

SWING DOOR | BEMINE  
JAMB | BEMINE WITH MATT LACQUERED ROPE TEMPERED GLASS  
STRUCTURE | MATT SATINED BRONZE ALUMINIUM  
PANELS | MATT LACQUERED ROPE TEMPERED GLASS  
HANDLE INSERT | P.3 TECSUEDE 3103

WITH / WITHOUT GLASS JAMB INSERT





SWING DOOR | BEMINE  
JAMB | BEMINE WITH P.3 ECO-LEATHER 62 INSERT  
STRUCTURE | BRIGHT ALUMINIUM  
PANELS | P.3 ECO-LEATHER 62  
HANDLE INSERT | FRAPPUCCINO MARBLE



PURE SURFACES WITH  
PRECIOUS INSERTS.





SWING DOOR | BEMINE  
JAMB | BEMINE WITH DIAMOND CREAM CERAMIC INSERT  
STRUCTURE | MATT SATINED BRONZE  
PANELS | DIAMOND CREAM CERAMIC  
HANDLE INSERT | P.3 TECSUEDE 3103





SWING DOOR | BEMINE  
JAMB | FILOMURO  
STRUCTURE | MATT SATINED BRONZE  
PANELS | GREY CERAMIC  
HANDLE INSERT | P.3 ECO-LEATHER 66

A hand holding a pen over a document, overlaid with a red tint. The text is centered in a white, serif font.

A CONTINUOUSLY  
GROWING PRODUCT LINE  
IN CONSTANT STYLISTIC  
EVOLUTION.

# TECHNICAL NOTES

## *Aluminium enlargement pads on BEMINE jamb* FOR GLOSSY FINISHES

CM 10 - CM 12,7

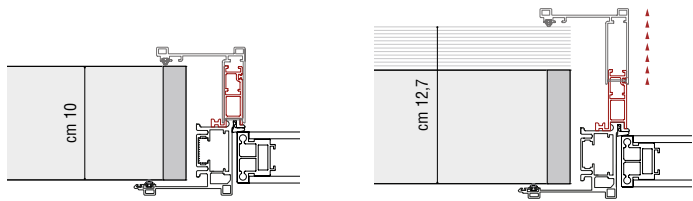

CM 12,8 - CM 17,5

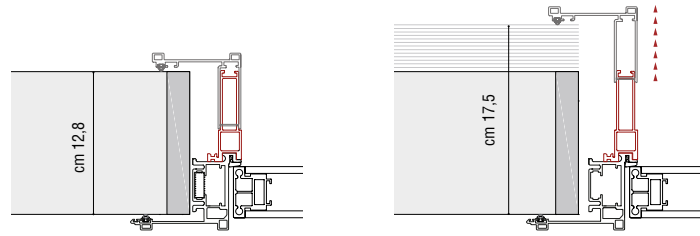

CM 17,6 - CM 20

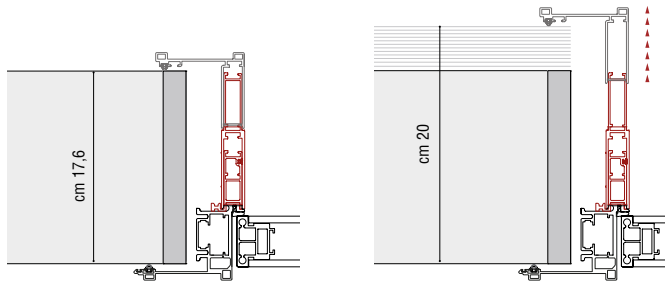

CM 20,1 - CM 24

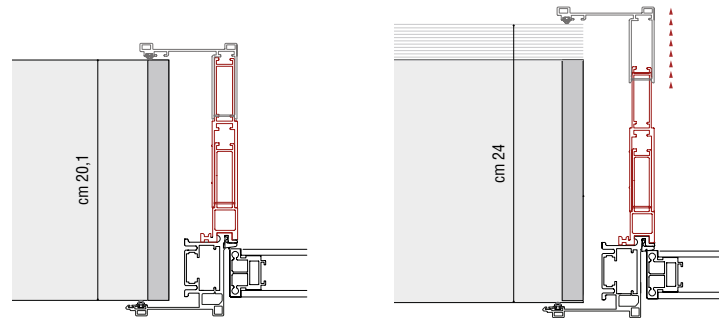

## *Wooden enlargement pads on BEMINE jamb* FOR MATT FINISHES

CM 10 - ONWARDS

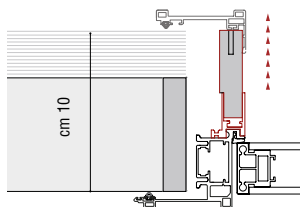

# TECHNICAL NOTES

## *Bemine finishes*

---

### STRUCTURE AND JAMB

#### *Aluminium*



MATT SATINED BRONZE

BRIGHT CHAMPAGNE GOLD

BRIGHT DARK BROWN  
ELECTROCOLOUR

BRIGHT ALUMINIUM

MATT DARK BROWN  
ELECTROCOLOUR

#### *Matt lacquered aluminium*



WHITE

CANAPA

ROPE

TURTLE DOVE

COFFEE

MOKA

PRUN

CEMENT GREY



LEAD GREY

GRANITE

SLATE GREY

NIGHT BLUE

BLACK

### PANEL

#### *Ceramics*



DIAMOND CREAM

EMPERADOR BROWN

GREY

#### *Mirrors*



MIRROR

BRONZE MIRROR

SMOKY MIRROR

FROSTED BRONZE MIRROR

FROSTED SMOKY MIRROR

PANEL AND INSERTS

*Glossy-matt wood*

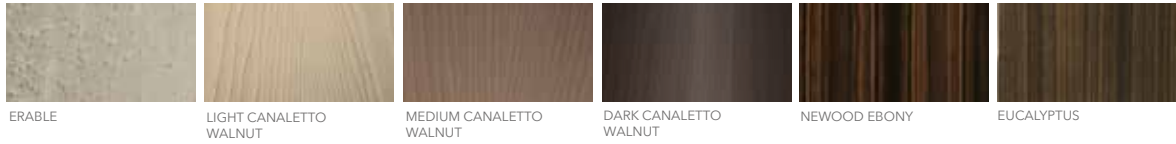

*Matt lacquered tempered glass*

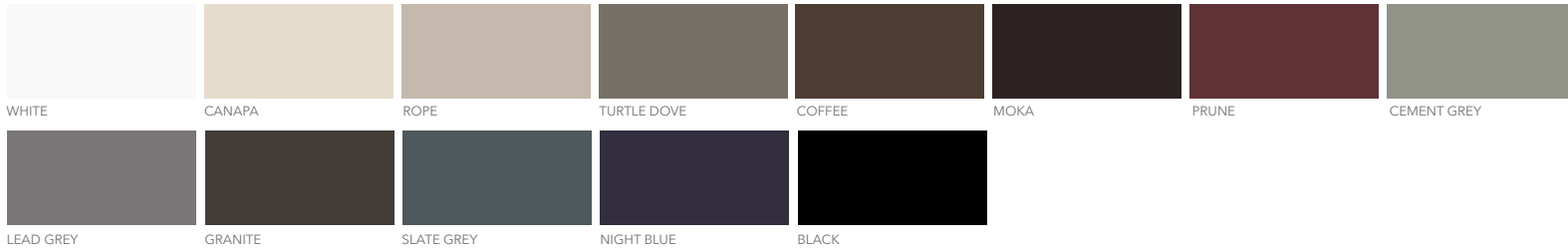

*Glossy lacquered tempered glass*



*Tecsuede Cat. P3*



*Eco-leather Cat. P3*

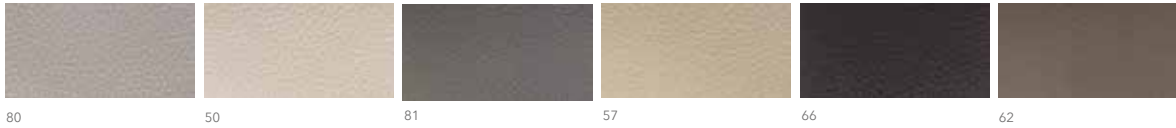

# TECHNICAL NOTES

## *handle*

---

### HANDLE FOR SWING DOOR



Inserts can be in the same finish of the panel or as per the special finishes listed on the right page.

*Gli inserti possono essere nella medesima finitura dell'anta o nelle finiture speciali elencate a destra.*

---

### MAGNETIC LOCK



SIMPLE LOCK



LOCK WITH LATCH

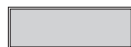

LOCK WITH KEY

---

### HANDLE STRUCTURE FINISH

#### *Aluminium*



MATT SATINED BRONZE



BRIGHT CHAMPAGNE GOLD



BRIGHT DARK BROWN  
ELECTROCOLOUR



BRIGHT ALUMINIUM



MATT DARK BROWN  
ELECTROCOLOUR

#### *Matt lacquered finish*

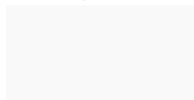

WHITE



CANAPA



ROPE

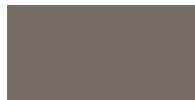

TURTLE DOVE



COFFEE

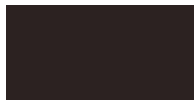

MOKA



PRUN



CEMENT GREY



LEAD GREY



GRANITE



SLATE GREY



NIGHT BLUE



BLACK

---

SPECIAL HANDLE INSERT

Onyx and marbles insert



RED ONYX



HONEY ONYX



IVORY ONYX



WHITE ONYX



GREEN ONYX



WHITE CARRARA MARBLE



IMPERIAL BROWN MARBLE



BARDIGLIO NUVOLATO MARBLE



VERDE GUATEMALA MARBLE



EMPERADOR DARK MARBLE



SILVER WAVE MARBLE



AGATHA BLACK MARBLE



ROSSO LEVANTO MARBLE



DOVER WHITE MARBLE



CALACATTA MARBLE



FRAPPUCCINO MARBLE



FUSION MULTICOLOR  
MARBLE



FUSION LIGHT MARBLE



PORTORO MARBLE



PATAGONIA MARBLE



JULIET PINK QUARTZ



BEOLA

Hand engraved insert



HAND ENGRAVED  
CAST BRASS



HAND ENGRAVED  
SILVER ALUMINIUM

# SPARK

designed by Opera Work in Progress | Serie\_3o8

Leggerezza e raffinata eleganza sono i tratti comuni nelle soluzioni proposte dal sistema Spark. Le sottili ma robuste strutture in alluminio anodizzato naturale, in elettrocolore moro o rivestite in essenza, contengono vetri stratificati conformi alle norme di sicurezza e temperati con esclusivi decori personalizzati.

*Lightness and refined elegance are the common features of solutions offered by the Spark system. The thin but sturdy structures in natural anodised aluminium, in electrocolour dark brown or wood veneer, contain tempered laminated glass compliant with safety standards and adorned with exclusive personalised decorations.*

*Легкость и изысканная элегантность - общие черты решений, предлагаемых системой Spark. Тонкие, но прочные конструкции из алюминия с натуральной анодированной отделкой, темно-коричневой электроокраской или облицованные деревом, содержат многослойное и закаленное стекло, отвечающее стандартам безопасности и украшенное эксклюзивным персонализированным декором.*

轻柔与精致的优雅，是Spark系统解决方案的特色。细薄却坚固的结构以原色阳极氧化铝，电解深棕色或外覆木材的样貌展现。内夹带个性化装饰，符合安全标准并经过强化处理的夹层玻璃。





SLIDING PANELS | SPARK  
STRUCTURE | MATT DARK BROWN ELECTROCOLOUR  
PANELS | CACAO SATIN GLASS



# TECHNICAL NOTES

## *Sliding door*

---

### DOOR SECTION



---

### DESIGN OPTIONS



Max cm 281,5

FULL PANEL



Max cm 281,5

PANEL WITH  
ALUMINIUM PROFILE

---

SLIDING DOOR WITH RAIL



WALL SLIDING

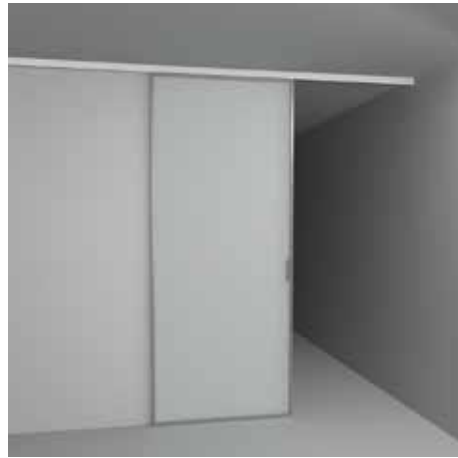

CEILING SLIDING

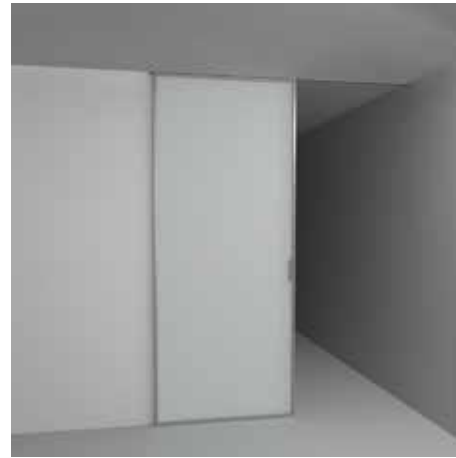

CEILING BUILT-IN SLIDING

---

POCKET SINGLE DOOR



FLAT JAMB



FREE JAMB

---

POCKET DOUBLE DOOR



FLAT JAMB



FREE JAMB

# TECHNICAL NOTES

## *modular system*

TRAVI DI SCORRIMENTO A SOFFITTO CON MASCHERINA 1 VIA  
*One way ceiling sliding rails with visible closing cover*



TRAVI DI SCORRIMENTO AD INCASSO A SOFFITTO A 1 VIA  
*One way ceiling built-in sliding rails*

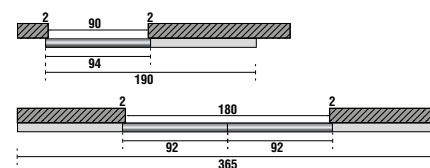

TRAVI DI SCORRIMENTO A SOFFITTO CON MASCHERINA 2 VIE  
*Two way ceiling sliding rails with visible closing cover*



TRAVI DI SCORRIMENTO AD INCASSO A SOFFITTO A 2 VIE  
*Two way ceiling built-in sliding rails*

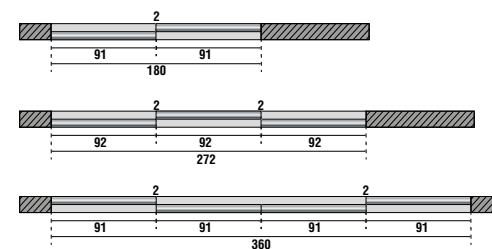

TRAVI DI SCORRIMENTO A SOFFITTO CON MASCHERINA 3 VIE  
*Three way ceiling sliding rails with visible closing cover*



TRAVI DI SCORRIMENTO AD INCASSO A SOFFITTO A 3 VIE  
*Three way ceiling built-in sliding rails*

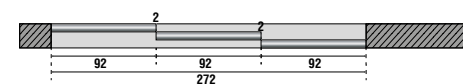

TRAVI DI SCORRIMENTO A PARETE CON MASCHERINA 1 VIA  
*One way wall sliding rails with visible closing cover*

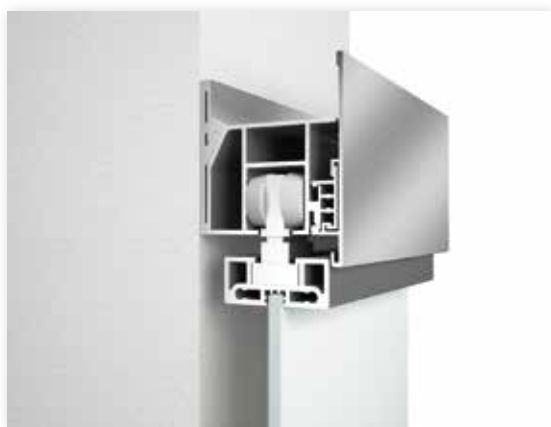

TRAVI DI SCORRIMENTO A PARETE AD INCASSO 1 VIA  
*One way wall built-in sliding rails*

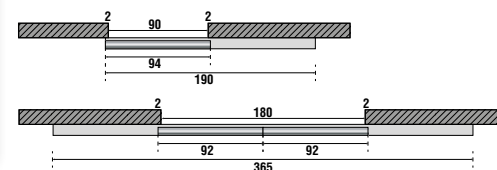

TRAVI DI SCORRIMENTO A PARETE CON MASCHERINA 2 VIE  
*Two way wall sliding rails with visible closing cover*



TRAVI DI SCORRIMENTO A PARETE AD INCASSO 2 VIE  
*Two way wall built-in sliding rails*

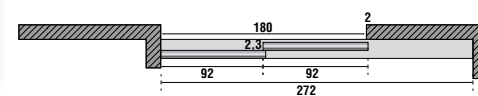

## *Soft opening / Soft close*

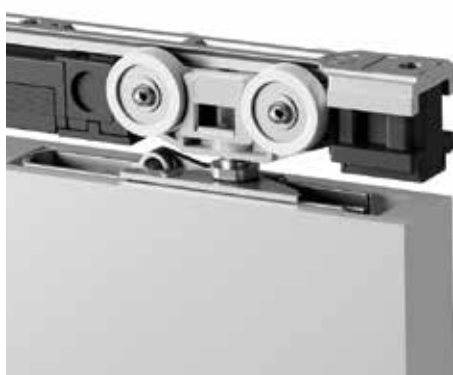

Gli ammortizzatori in apertura e chiusura sono applicati per una ottimale frenatura e silenziosità. Per porte min. 70 cm

*The soft closing / opening dampers are available for an optimal braking motion and noiseless sliding quality. For doors min. 70 cm*

# TECHNICAL NOTES

## *Swing doors*

DOOR SECTION



OPENING



STANDARD

DESIGN OPTIONS



FULL PANEL



PANEL WITH  
ALUMINIUM PROFILE

---

SINGLE SWING DOOR



FLAT JAMB



FILOMURO JAMB

---

DOUBLE SWING DOOR



FLAT JAMB



FILOMURO JAMB



SLIDING PANELS | SPARK  
STRUCTURE | MATT DARK BROWN ELECTROCOLOUR  
PANELS | STOP-SOL BRONZE

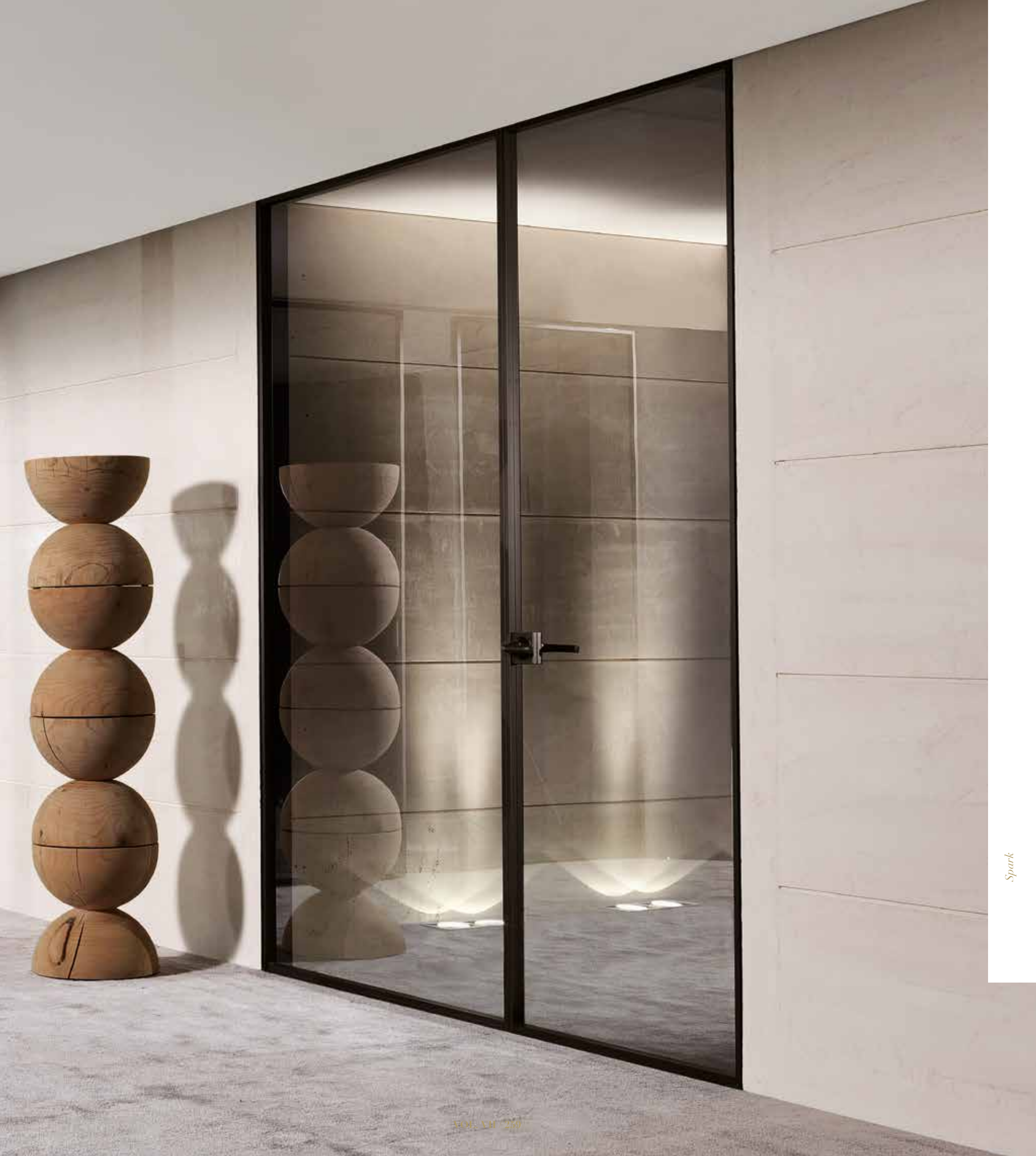





SWING PANELS | SPARK  
STRUCTURE | MATT DARK BROWN ELECTROCOLOUR  
PANELS | STOP-SOL BRONZE





SLIDING PANELS | SPARK  
STRUCTURE | MATT DARK BROWN ELECTROCOLOUR  
PANELS | TRANSPARENT TEMPERED BRONZE GLASS

YVES SAINT LAURENT

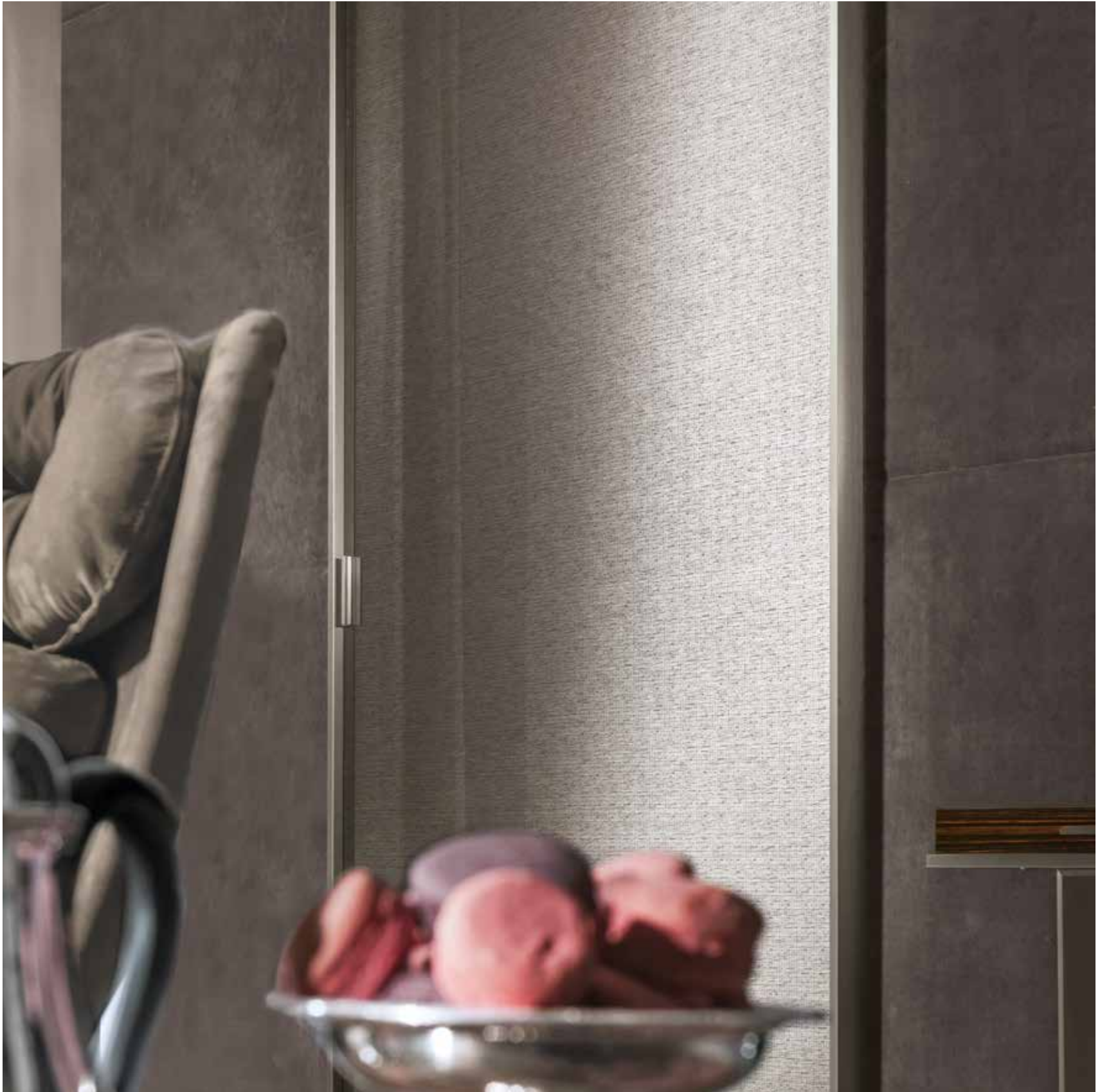

# Laminated glass

INTERIORS CAN BE CUSTOMISED WITH A HIGHLY DECORATIVE LOOK: NEW TRANSPARENT GLASS IN NEUTRAL COLOURS. THE LAMINATED GLASS CONTAINS A LAYER OF FABRIC OR METAL MESH WITH A TIGHT WEAVE AND A DELICATE PATTERN.

Interni personalizzati ad alto contenuto decorativo: nuove trasparenze dai colori neutri, il vetro stratificato racchiude uno strato di tessuto o metal mesh dalla fitta trama e dal tratteggio delicato.

Персонализированные интерьеры с высоким декоративным содержанием: новые прозрачные материалы нейтральных оттенков, многослойное стекло заключает в себе нежный слой ткани или мелкой металлической сетки.

装饰性很强的个性化内饰：中性色的新型透明胶片，夹层玻璃包裹一层质地密实的织物或金属网 并配以细腻的线条。

EXNER TOBACCO  
NEUTRAL GLASS



EXNER TOBACCO  
BRONZE GLASS



EXNER TAUPÈ  
NEUTRAL GLASS



EXNER TOBACCO  
GREY GLASS



METAL MESH







SLIDING PANELS | SPARK  
STRUCTURE | MATT SATINED BRONZE  
PANELS | TOBACCO EXNER BRONZE GLASS  
ENDLESS BOISERIE | P.3 TECSUEDE 5311

*Spark*



GLASS WITH “METAL MESH” INSERT

SLIDING PANELS | SPARK  
STRUCTURE | MATT DARK BROWN ELECTROCOLOUR  
PANELS | TRANSPARENT GLASS WITH METAL MESH INSERT





# BIQUADRIO *exclusive design*

“BIQUADRIO” IS INSPIRED BY THE WORLD OF TEXTILES, REPRODUCING A DELICATE WEAVE ON THE SURFACE OF THE GLASS. THE SEMI-TRANSPARENCY LENDS COSINESS AND WARMTH TO THE ROOM.

“Biquadrio” si ispira al mondo del tessile riproducendo una trama delicata sulla superficie del vetro. La semitrasparenza conferisce intimità e calore all'ambiente.

Навеянная текстилем идея декора “Biquadrio” воспроизводит переплетение нитей на поверхности стекла. Полупрозрачность придает помещению тепло и уют.

“Biquadrio” 的灵感来自纺织品世界，在玻璃表面再现精致纹理。半透明给环境带来了亲密和温暖。

BIQUADRIO FROSTED  
TEMPERED NEUTRAL

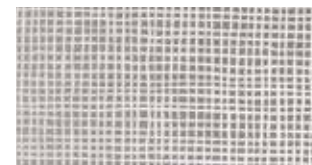

BIQUADRIO FROSTED  
TEMPERED GREY

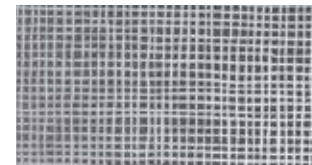

BIQUADRIO FROSTED  
TEMPERED BRONZE

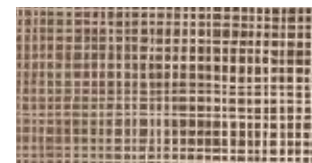





SLIDING PANELS | SPARK  
STRUCTURE | NATURAL ANODISED ALUMINIUM  
PANELS | BIQUADRIO FROSTED TEMPERED NEUTRAL





SLIDING PANELS | SPARK  
STRUCTURE | ALUMINIUM COVERED IN ECOWOOD CANALETTO WALNUT  
PANELS | BIQUADRIO FROSTED TEMPERED NEUTRAL



SLIDING PANELS | SPARK  
STRUCTURE | ALUMINIUM COVERED IN NEWOOD EBONY  
PANELS | CACAO SATIN GLASS

# ECOWOOD

ALUMINIUM PROFILES ARE VENEERED  
IN MULTI-LAMINATE WOOD THAT  
GUARANTEES UNIFORM COLOUR.  
THE VENEER IS ENVIRONMENTALLY  
FRIENDLY: THE WOODS COME FROM  
CERTIFIED LOW IMPACT FORESTS.

I profili in alluminio sono rivestiti da un'impiallacciatura di legno multilaminare, che garantisce uniformità cromatica costante agendo nel massimo rispetto del territorio: le essenze selezionate e certificate provengono da foreste con gestione a basso impatto ambientale.

Алюминиевые профили имеют отделку из многослойного шпона, обеспечивающего не только не изменяющуюся во времени равномерность цвета, но и, прежде всего - максимальную охрану территории, т. к. используются породы дерева из сертифицированных лесов с экологическим управлением.

铝材边框外覆多层木贴面板，以确保长时间保有色彩均匀的特色，此外也做到环保尊重领土：选用的木材皆经过认证，源自在管理上对环境造成低冲击的森林。

ECOWOOD CANALETTO



NEWOOD EBONY





FROSTED GLASS

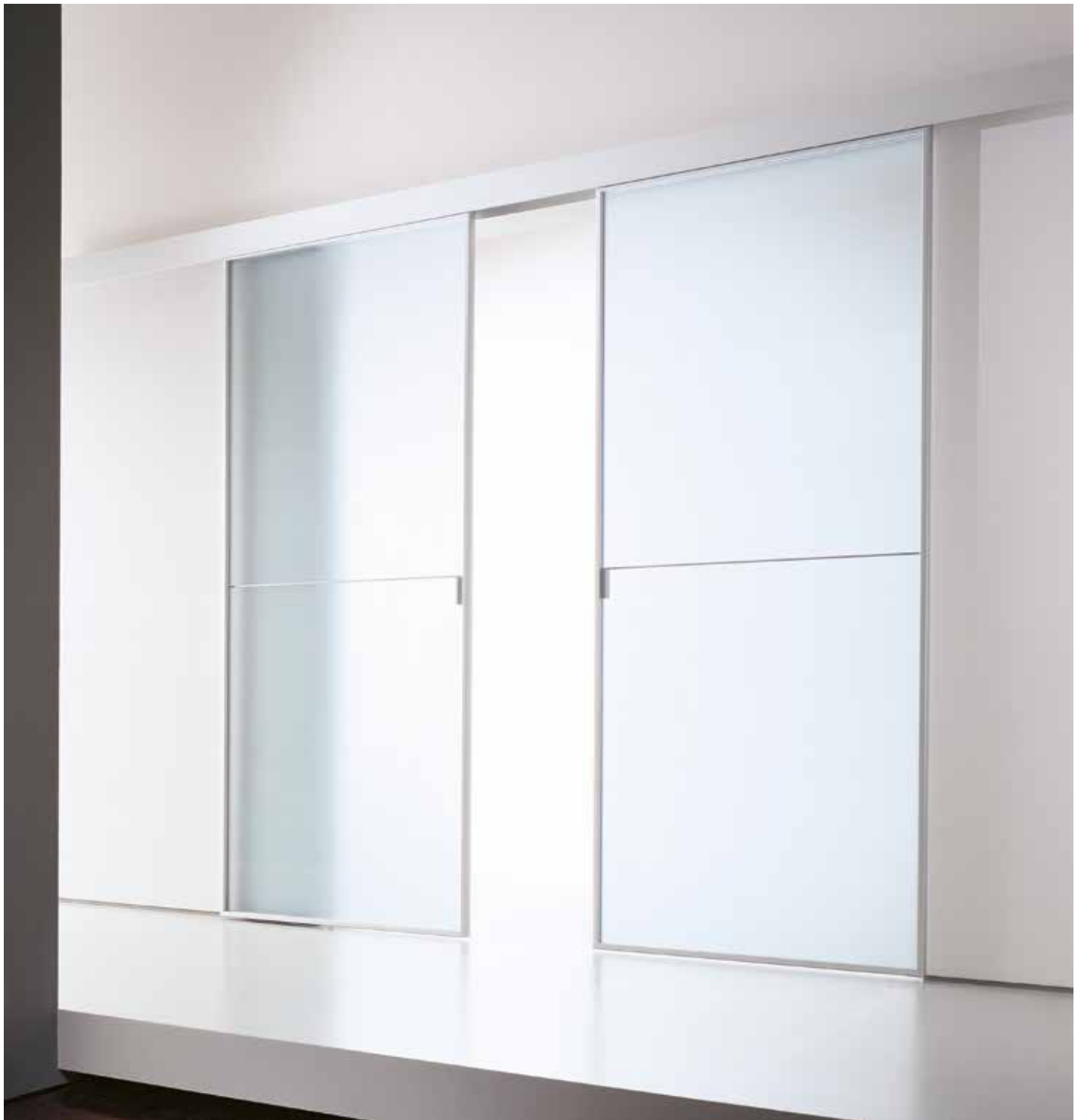

SLIDING PANELS | SPARK  
STRUCTURE | NATURAL ANODISED ALUMINIUM  
PANELS | FROSTED NEUTRAL GLASS

*Spark*



SWING DOOR | SPARK  
STIPITE | JAMB FLAT  
STRUCTURE | MATT SATINED BRONZE ALUMINIUM  
PANELS | EXNER TAUPE NEUTRAL GLASS

# *FLAT jamb*

MODERNITY AND TRADITION  
MEET UP IN SOBER ELEGANT STYLE.

Stile sobrio ed elegante, incontro tra modernità e tradizione.

Лаконичный элегантный стиль, объединяющий современность и традиции.

沉稳优雅的风格，现代与传统的交汇。

## *Enlargement pads on FLATjamb*

CM 9,5 - CM 12

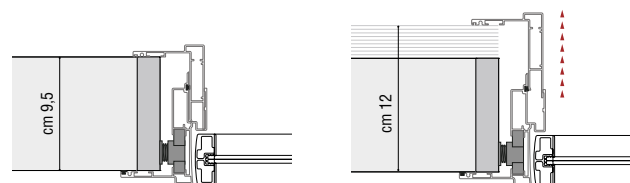

CM 9,5 - ONWARDS (WOODEN ENLARGEMENT PAD)

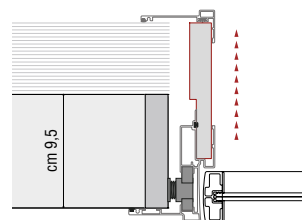

# TECHNICAL NOTES

*Door with FLAT jamb*

---

SWING DOOR WITH FLAT JAMB



---

POCKET SLIDING DOOR WITH FLAT JAMB

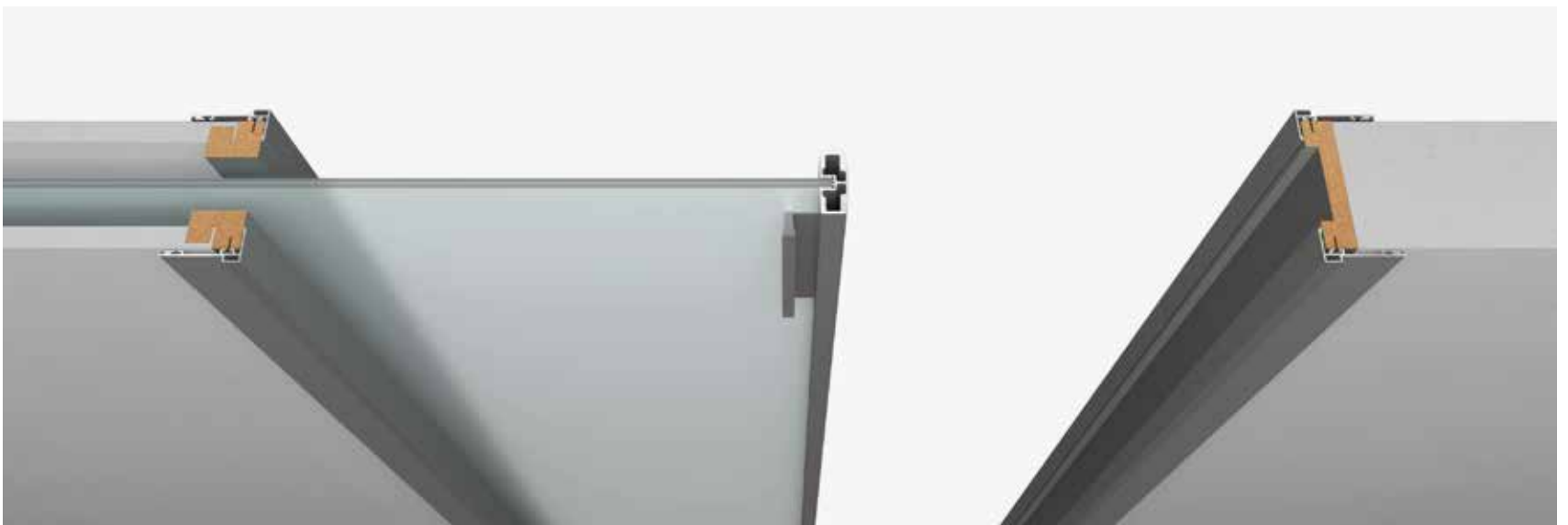





SWING DOOR | SPARK  
JAMB | FLAT  
STRUCTURE | BRIGHT DARK BROWN ELECTROCOLOUR  
PANEL | WELTON FROSTED TEMPERED BRONZE

# WELTON *design*

GLASS WITH SATIN DECORATION,  
MADE EXCLUSIVELY FOR LONGHI.  
A CLASSIC PATTERN THAT COMBINES  
ELEGANCE AND PURITY.

Vetro con decoro satinato realizzato in esclusiva per Longhi. Pattern dal gusto classico, una fusione di eleganza e purezza.

Стекло с сатинированным декором, изготовленное эксклюзивно для Longhi. Классический рисунок, слияние элегантности и чистоты.

专为 Longhi 打造的缎面装饰玻璃。图案品味经典，融合了优雅与纯洁。

WELTON FROSTED  
TEMPERED NEUTRAL



WELTON FROSTED  
TEMPERED GREY



WELTON FROSTED  
TEMPERED BRONZE





# DORAL *design*

ELEGANT SATIN-FINISHED AND  
TRANSPARENT TONES AVAILABLE  
IN BRONZE, GREY AND NEUTRAL.

Eleganti toni di satinature e trasparenze disponibili nei colori: bronzo, grigio e neutro.

Эlegantные оттенки сатинированных и прозрачных линий предлагаются следующих цветов: бронза, серый и нейтральный.

优雅的缎面和透明的色调，有以下颜色可供选择：青铜色、灰色和中性色。

DORAL FROSTED  
TEMPERED NEUTRAL



DORAL FROSTED  
TEMPERED GREY



DORAL FROSTED  
TEMPERED BRONZE







SWING DOOR | SPARK  
JAMB | FLAT  
STRUCTURE | MATT SATINED BRONZE  
PANEL | DORAL FROSTED TEMPERED BRONZE  
ENDLESS BOISERIE | P.3 TECSUEDE 5311



SWING DOOR | SPARK  
JAMB | FLAT  
STRUCTURE | BRIGHT DARK BROWN ELECTROCOLOUR  
PANEL | DURINI FROSTED TEMPERED BRONZE

# DURINI *design*

PARALLEL TRANSPARENT AND  
SATIN-FINISH LINES ALTERNATE  
FOR A TIMELESS, MODERN EFFECT.

Linee parallele trasparenti e satinare si alternano per un effetto moderno e senza tempo.

Чередование параллельных прозрачных и сатирированных линий создает современный, всегда актуальный эффект.

透明和緞面平行线交替呈现现代而永恒的效果。

DURINI FROSTED  
TEMPERED NEUTRAL



DURINI FROSTED  
TEMPERED GREY

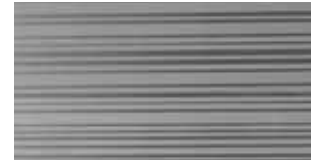

DURINI FROSTED  
TEMPERED BRONZE







SLIDING PANELS | SPARK  
STRUCTURE | BRIGHT DARK BROWN ELECTROCOLOUR  
PANEL | DURINI FROSTED TEMPERED BRONZE

# TECHNICAL NOTES

## *FILOMURO jamb / FREE jamb*

SWING DOOR WITH FILOMURO JAMB



POCKET SLIDING DOOR WITH FREE JAMB



SWING DOOR | SPARK  
JAMB | FILOMURO  
STRUCTURE | NATURAL ANODISED ALUMINIUM  
PANEL | GLOSSY LACQUERED LAMINATED BLACK GLASS







SWING DOOR | SPARK  
JAMB | FILOMURO  
STRUCTURE | NATURAL ANODISED ALUMINIUM  
PANEL | GLOSSY LACQUERED LAMINATED TURTLE DOVE GLASS





SWING DOOR | SPARK  
JAMB | FILOMURO  
STRUCTURE | NATURAL ANODISED ALUMINIUM  
PANEL | GLOSSY LACQUERED LAMINATED WHITE GLASS

# TECHNICAL NOTES

## *Spark finishes*

---

### STRUCTURE AND JAMB

#### *Aluminium*



MATT SATINED BRONZE    MATT PLATINUM    NATURAL ANODISED ALUMINIUM    BRIGHT DARK BROWN ELECTROCOLOUR    MATT DARK BROWN ELECTROCOLOUR

#### *Matt lacquered aluminium*

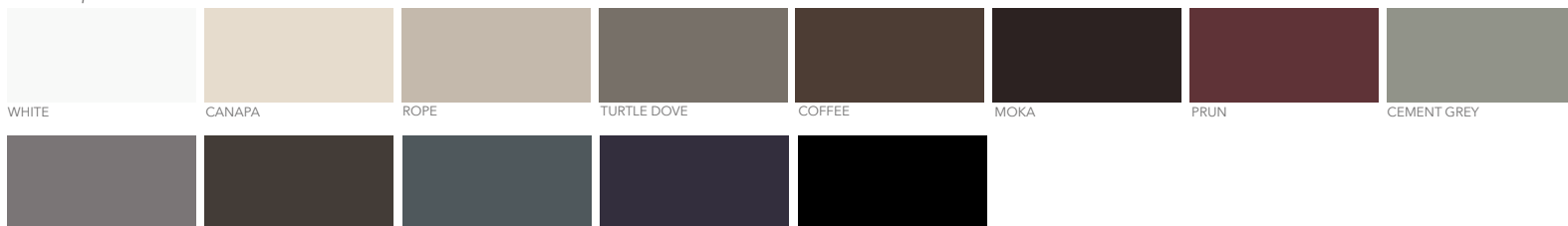

WHITE    CANAPA    ROPE    TURTLE DOVE    COFFEE    MOKA    PRUN    CEMENT GREY

LEAD GREY    GRANITE    SLATE GREY    NIGHT BLUE    BLACK

---

### STRUCTURE AND JAMB



ECOWOOD CANALETTO WALNUT    NEWOOD EBONY

---

### PANELS

#### *Frosted glass*



LAMINATED FROSTED NEUTRAL    TEMPERED FROSTED BRONZE    TEMPERED FROSTED GREY    TEMPERED FROSTED DARK FUMÉ    LAMINATED GRAPHITE    LAMINATED CACAO    LAMINATED ICE

#### *Transparent glass*



TRANSPARENT LAMINATED NEUTRAL    TEMPERED BRONZE    TEMPERED GREY    TEMPERED DARK FUMÉ

#### *Reflective glass*



STOP-SOL BRONZE    STOP-SOL GREY

---

PANEL AND INSERT

*Glass with fabric insert*

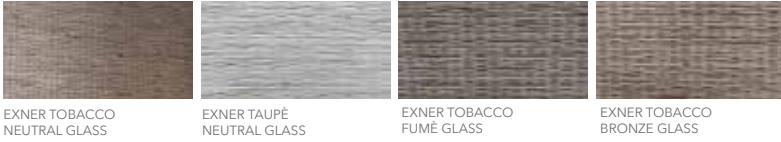

*Glass with "metal mesh" insert*



*Decorated frosted glass*

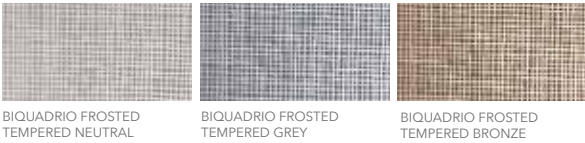
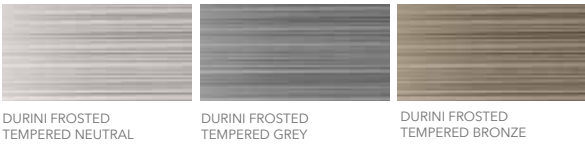

*Glossy lacquered laminated glass*



# TECHNICAL NOTES

## *handle*

---

### HANDLE FOR SWING DOOR



---

### LOCKING SYSTEM

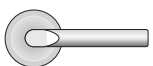

SIMPLE LOCK



LOCK WITH LATCH



LOCK WITH KEY

---

### HANDLE STRUCTURE FINISH

*Aluminium matt painted*



BRONZE



PLATINUM



NATURAL



DARK BROWN

---

HANDLE FOR SLIDING DOOR



---

LOCKING SYSTEMS



LOCK WITH LATCH

---

HANDLE STRUCTURE FINISH

*Aluminium*



MATT SATINED BRONZE

MATT PLATINUM

BRIGHT DARK BROWN  
ELECTROCOLOUR

NATURAL ANODISED  
ALUMINIUM

MATT DARK BROWN  
ELECTROCOLOUR

*Matt lacquered aluminium*



WHITE

CANAPA

ROPE

TURTLE DOVE

COFFEE

MOKA

PRUN

CEMENT GREY



LEAD GREY



GRANITE



SLATE GREY



NIGHT BLUE



BLACK



# BOISERIE SWELLS



FOREVER BOISERIE

pg 306



LAND BOISERIE

pg 348



ENDLESS BOISERIE

pg 366

# FOREVER BOISERIE

designed by Anna & Enrico Cattaneo | Serie\_343

Forever system è una nuova visione di arredo, capace di trasformare lo spazio, esaltando l'architettura d'interni. Il sistema si veste con finiture innovative e ricercate che impreziosiscono ogni ambiente. Forever system si compone di molteplici elementi integrati tra loro ed è facilmente riconoscibile grazie ai suoi elementi morbidi, che identificano questo sistema, come i raccordi delle pareti, le nicchie decorative e gli stipiti delle porte.

I raccordi terminali e angolari sono proposti in due varianti (concavi/convessi o con spigoli a 90°) e donano all'ambiente un aspetto completamente rinnovato. La luce a led, soffusa e delicata, dona atmosfera a tutto l'ambiente e caratterizza le attrezzature a parete, come le mensole e i vani. Questi ultimi hanno dimensioni e funzioni differenti: da piccole librerie fino ad ampie consolle o scrittoi. Forever system può anche spogliarsi della sua morbidezza e trasformarsi in una boiserie rigorosa, con porte a battente complanari, sia a tirare che a spingere.

*Forever system is a new vision of furniture, capable of transforming space and enhancing interior architecture. The system comes in innovative sophisticated finishes that embellish every room. Forever system consists of multiple integrated elements and is easily recognisable thanks to its soft identifying elements, such as wall fittings, decorative alcoves and door jambs.*

*The end and corner fittings come in two variants (concave/convex or with 90° corners) and give the room a completely new look. Soft gentle LED light lends atmosphere to the entire room and characterises wall fittings such as shelves and storage units. The latter feature different sizes and functions: from small bookcases to large console tables or desks. Forever system can also be stripped of its softness and transformed into a minimal boiserie, with flush hinged doors, either pull or push.*

*Forever system - это новое видение обстановки, преобразующей пространство, подчеркивая особенности архитектурных решений интерьеров. Система используется с инновационными изысканными видами отделки, повышающими ценность любого помещения. Forever system состоит из многочисленных интегрированных между собой компонентов и легко узнаваема благодаря характеризующим ее мягким элементам: соединителям стен, декоративным нишам и дверным косякам.*

*Концевые и угловые соединители предлагаются в двух вариантах (вогнутые/выпуклые или с кромками под 90°) и полностью обновляют внешний вид помещения. Мягкий приглушенный свет от светодиодной подсветки создает атмосферу во всем помещении и выделяет настенные элементы: полки и ниши. Ниши имеют разные размеры и выполняют различные функции: от маленьких книжных шкафов до больших консолей или письменных столов. Forever system может быть также представлена без мягкой отделки, превращаясь в стеновую панель как таковую, с дверями с компланарными створками, открывающимися на и от себя.*

Forever system 是家装的新视野，能够改变空间，提升室内建筑。该系统凭其创新而精巧的面饰，轻松驾驭任何环境。Forever system 由多种元素相互集合而成，其中最具标志性的便是柔软元素，例如墙壁连接处、装饰壁龛和门框。

末端和拐角连接有两种变体（凹面/凸面或 90° 边缘），让房间焕然一新。柔和精致的 LED 灯光打造整体氛围并刻画壁挂设备，如隔板和隔间。后者有多种尺寸和功能可供选择：从小书柜到大控制台或书桌。Forever system 也可从柔软转化成硬朗的墙面镶板，配以可推拉的共面铰链门。



FULL PANEL

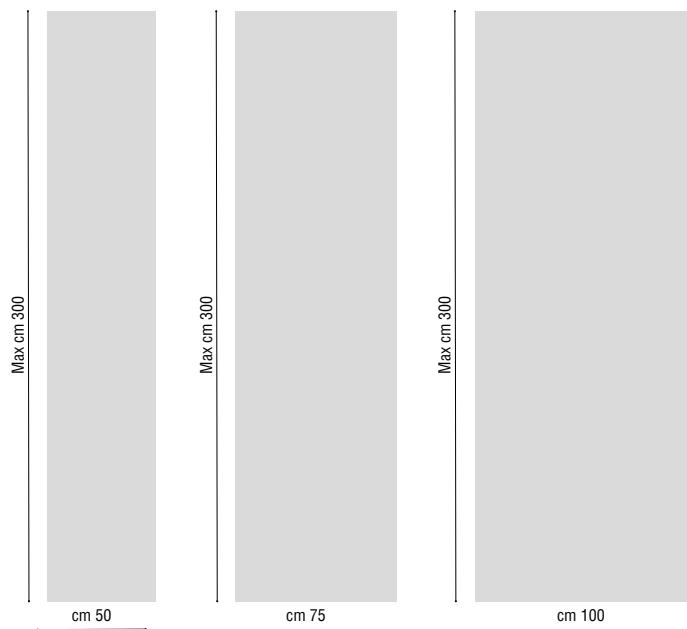

PANEL WITH ALUMINIUM PROFILE

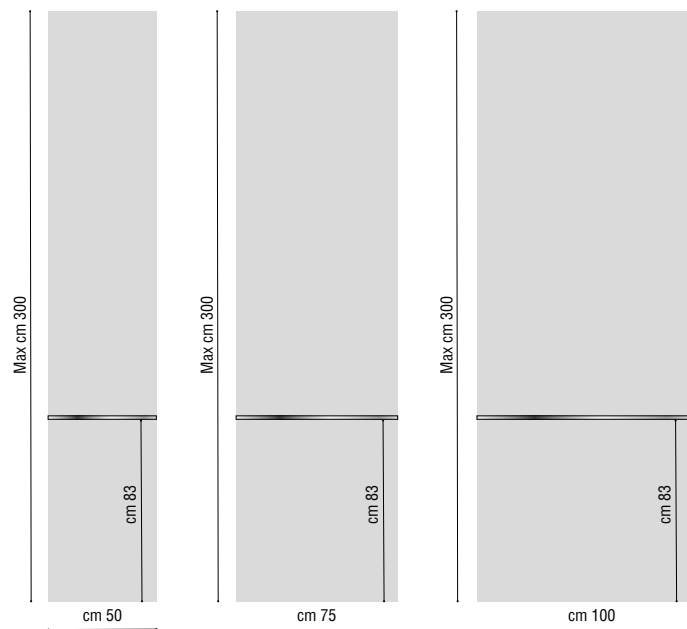

NICHES

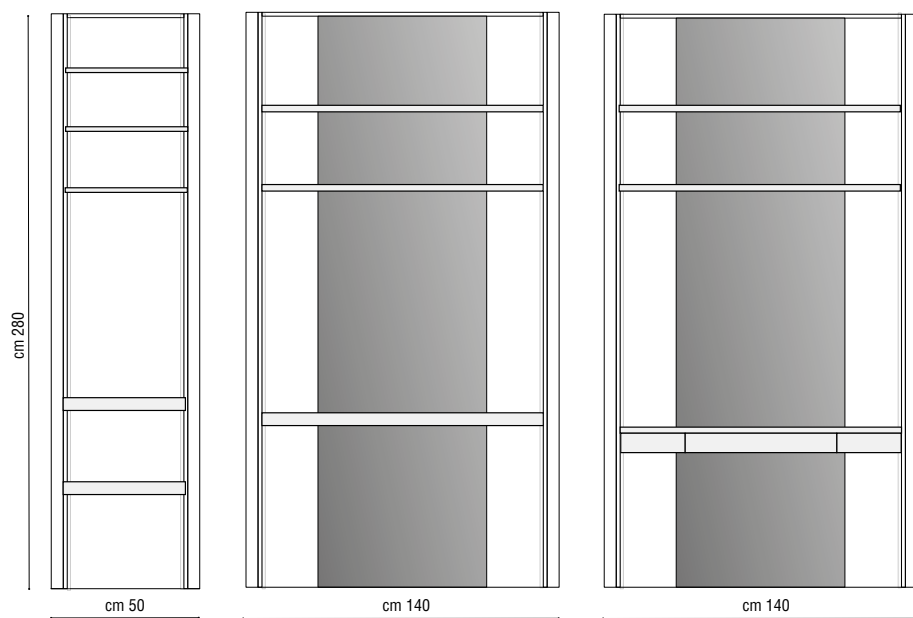

SHELVES

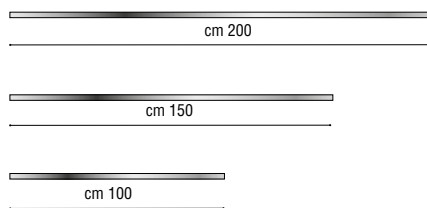

# FOREVER BOISERIE

FOREVER CONSISTS OF MULTIPLE INTEGRATED ELEMENTS SUCH AS THE WALL FITTINGS, DECORATIVE NICHEs AND SHELVES WITH LED.

Forever system si compone di molteplici elementi integrati come i raccordi delle pareti, le nicchie decorative e mensole con illuminazione LED.

*Forever system состоит из многочисленных интегрированных между собой компонентов, например, соединителей стен, декоративных ниш и дверных косяков.*

Forever system 由多种元素相互集合而成，例如墙壁连接处、装饰壁龛和门框。





FOREVER BOISERIE | P.3 TECSUEDE 5105 + P.3 TECSUEDE 5604  
PROFILE | MATT CHAMPAGNE  
SHELVES BACK | EMPERADOR BROWN CERAMIC





FOREVER BOISERIE | P.3 TECSUEDE 5105 + P.3 TECSUEDE 5604  
PROFILE | MATT CHAMPAGNE  
NICHE SHELVES | TRANSPARENT GLASS + GLOSSY EBONY

VOL. VII / 313



FOREVER BOISERIE | P.3 TÈCSUÈDE 5120 - EMPERADOR BROWN CERAMIC  
PROFILE | MATT BRONZE

# PANEL *with horizontal profile*

THE BOISERIE PANEL WITH CROSSBAR  
ENABLES THE COMBINATION OF  
DIFFERENT MATERIALS FROM THE  
SAMPLE COLLECTION.

Il pannello della boiserie con traverso permette di combinare i diversi materiali proposti a campionario.

Панель буазери с поперечиной позволяет комбинировать различные представленные в образцах материалы.

带横梁的墙面镶板可以依样本挑选不同材料进行组合。





FULL PANEL

FOREVER BOISERIE | P.3 TECSUEDE 5120 + DIAMOND CREAM CERAMIC  
PROFILE | MATT CHAMPAGNE





FOREVER BOISERIE | P.3 TECSUEDE 5604  
PROFILE | MATT BRONZE  
SHELVES BACK | EMPERADOR BROWN CERAMIC







FOREVER BOISERIE | P.3 TECSUEDE 5105 + GLOSSY ERABLE  
PROFILE | MATT BRONZE  
SHELVES BACK | DIAMOND CREAM CERAMIC

SHELVES WITH LED LIGHT

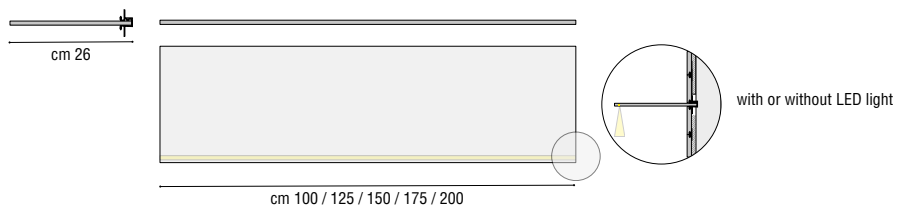
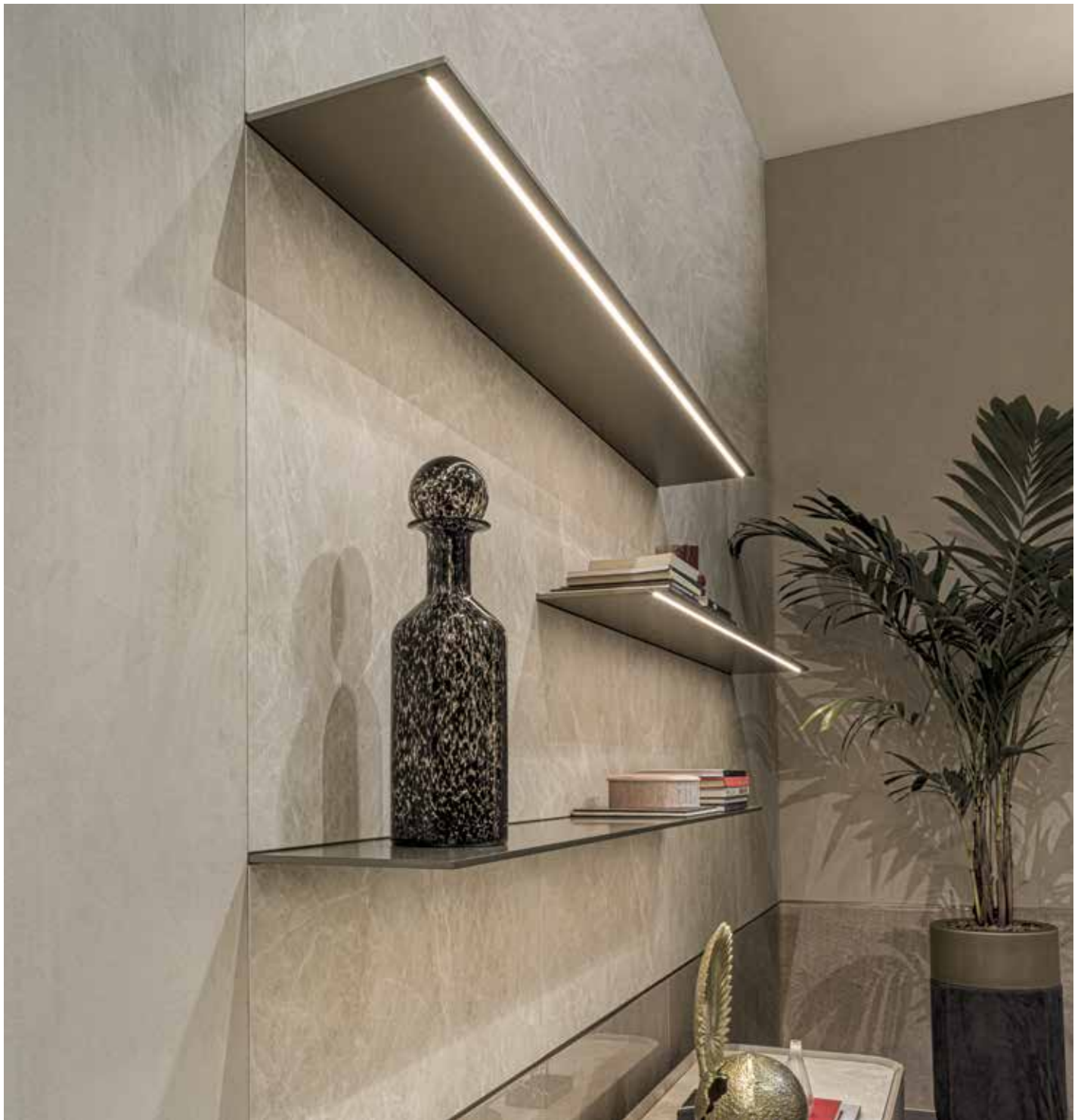



VERTICAL RIBBING

BOISERIE | FOREVER  
SHELVES BACK | P.3 TECSUEDE 5105 WITH VERTICAL RIBBING







FOREVER BOISERIE | P.3 TECSUEDE 5311  
SHELVES BACK | P.3 TECSUEDE 5311 WITH VERTICAL RIBBING



SHELVES ON CERAMIC / WOOD PANELS

SHELVES ON CLADDED PANELS







FOREVER BOISERIE | P.3 TROUSSE 5120 + MATT ERABLE  
PROFLE | MATT CHAMPAGNE

NOI-VII-331





FOREVER BOISERIE | P.3 TECSUEDE 5120 + GLOSSY ERABLE  
SHELVES BACK | GLOSSY ERABLE  
PROFILE | MATT BRONZE

# TECHNICAL NOTES

## *Wall fittings*

BOISERIE WITH STRAIGHT FITTINGS

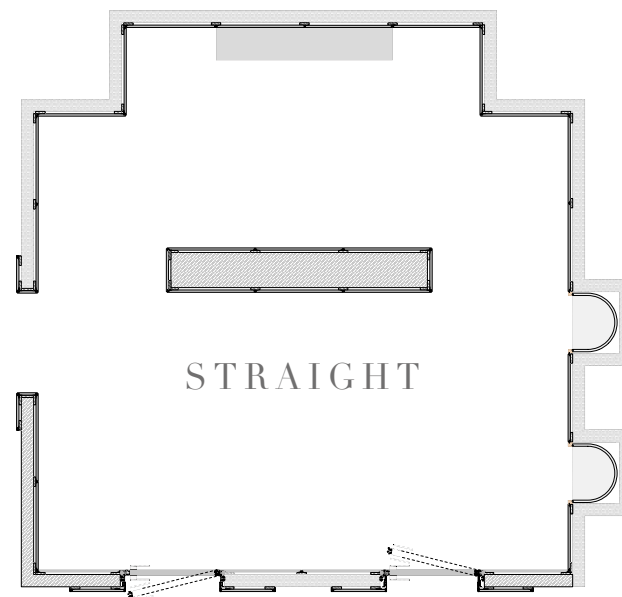

BOISERIE WITH CURVED FITTINGS

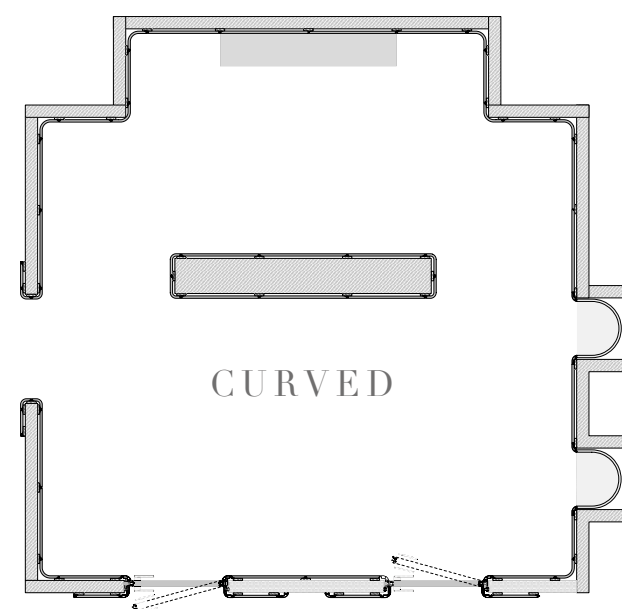

CURVED FITTINGS

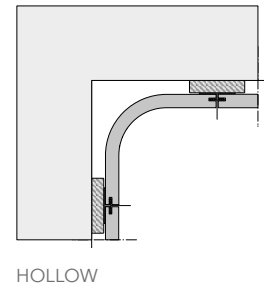
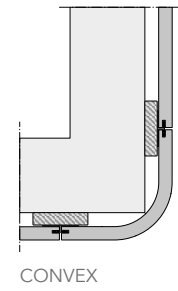



CURVED END TRIM

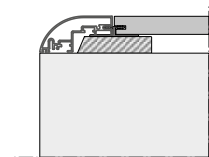



STRAIGHT END TRIM

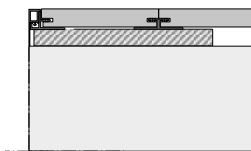

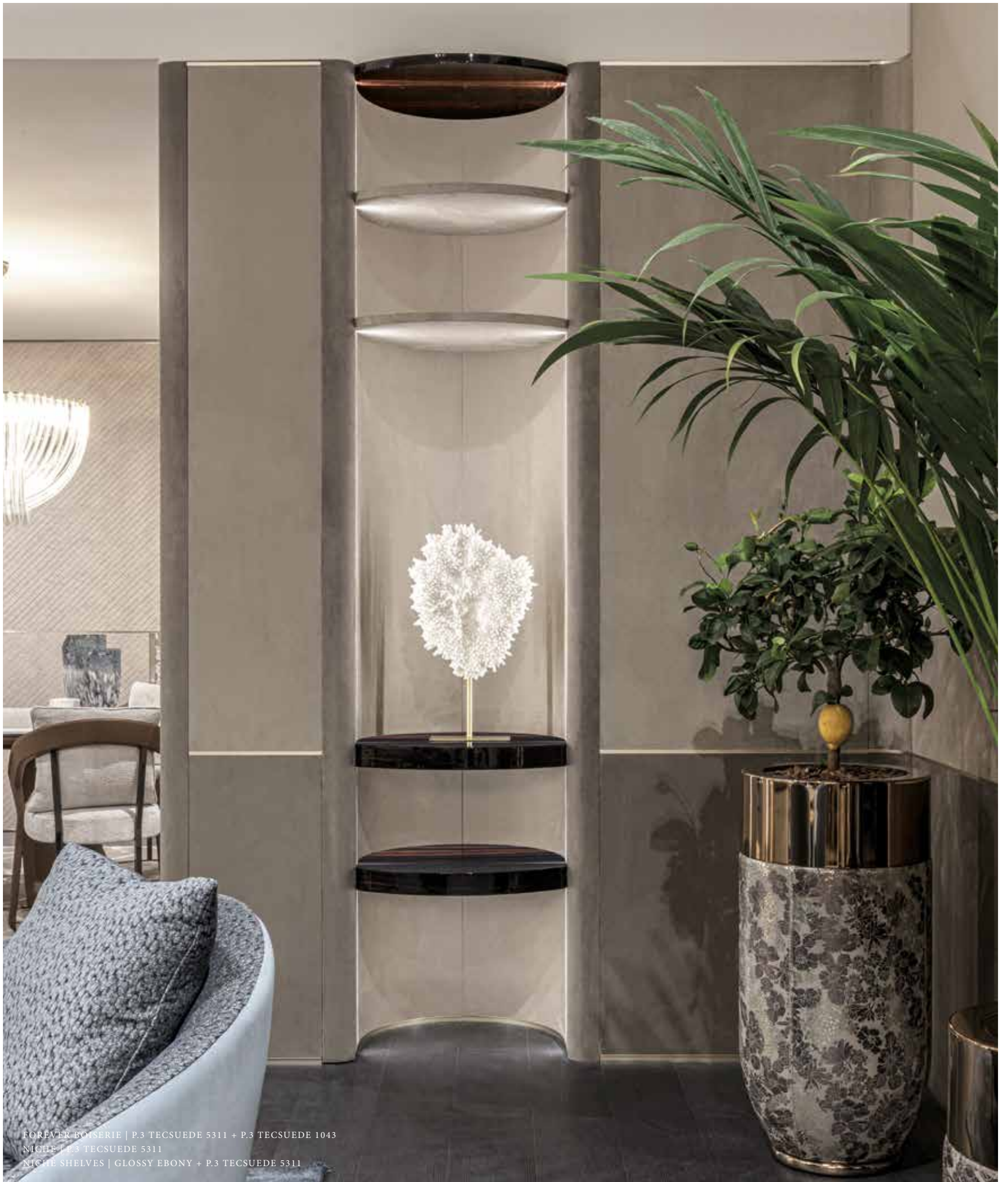

FOREVER BOISERIE | P.3 TECSUEDE 5311 + P.3 TECSUEDE 1043  
NICHE | P.3 TECSUEDE 5311  
NICHE SHELVES | GLOSSY EBONY + P.3 TECSUEDE 5311

NICHE WITH UPPER COVERED SHELVES



VOL. VII / 339





NICHE WITH UPPER GLASS SHELVES

FOREVER BOISERIE | P.3 TECSUEDE 5311

NICHE | P.3 TECSUEDE 5311

NICHE SHELVES | TRANSPARENT FUMÉ GLASS + GLOSSY EBONY





NICHE WITH DESK



FOREVER BOISERIE | P.3 TECSUEDE 5311 + P.3 TECSUEDE 1043  
NICHE | P.3 TECSUEDE 5311  
NICHE SHELVES | TRANSPARENT FUMÈ GLASS + GLOSSY EBONY



FOREVER BOISERIE | P.3 TECSUEDE 5120  
NICHE | P.3 TECSUEDE 5120  
NICHE MAKE-UP | GLOSSY ERABLE

NICHE 60 CM

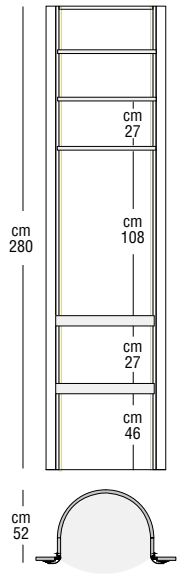

SHELVES VERSION

NICHE 140 CM

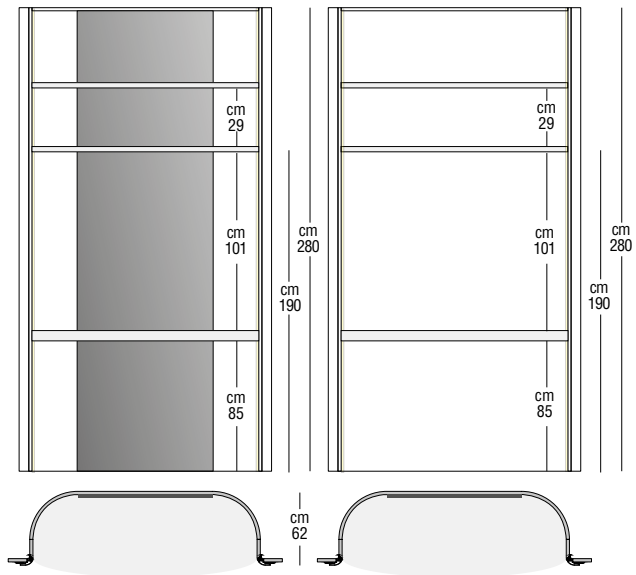

DESK VERSION

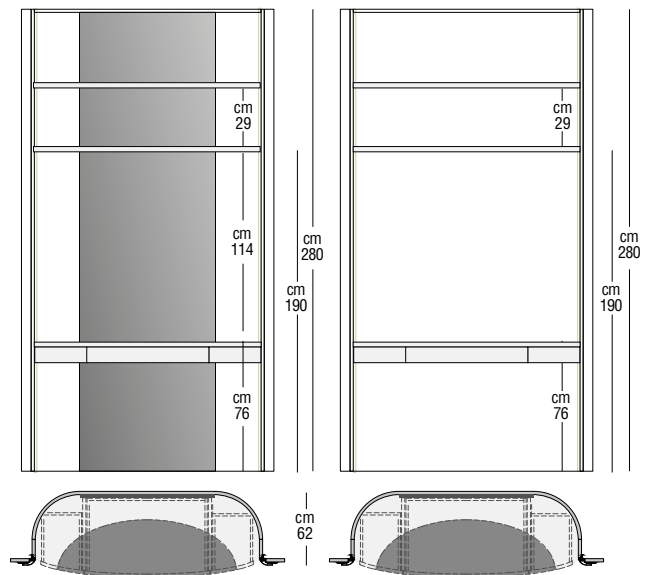

MAKE-UP VERSION

# TECHNICAL NOTES

## *Forever finishes*

---

### PROFILES

*Matt aluminium*



CHAMPAGNE



BRONZE



MOKA

---

PANEL

*Tecsuede Cat. P3*



5311

3103

5120

1043

5105

5604

1012

5119

*Eco-leather Cat. P3*



80

50

81

57

66

62

---

PANEL WITH VERTICAL RIBBING

*Tecsuede Cat. P3*



5311

3103

5120

1043

5105

5604

1012

5119

---

*Ceramics*



DIAMOND CREAM

EMPERADOR BROWN

GREY

*Matt/glossy wood*



ERABLE

LIGHT CANALETTO  
WALNUT

MEDIUM CANALETTO  
WALNUT

DARK CANALETTO  
WALNUT

NEWOOD EBONY

EUCALYPTUS

# LAND BOISERIE

designed by Alessandro La Spada | Serie\_341

La Boiserie Land è un sistema modulare che unisce porte, pannelli scorrevoli, boiserie e mobili contenitori di servizio. Si caratterizza per un'estrema adattabilità ad ogni tipo di ambiente, per i materiali utilizzati, ma soprattutto per le linee parallele e perpendicolari scandite da profili metallici che definiscono in maniera contemporanea e moderna la superficie. La serie comprende molteplici abbinamenti e modularità dalle dimensioni quasi personalizzate. Il sistema è diviso per moduli e si articola in diverse larghezze e possibilità di aperture.

*The Boiserie Land is modular system that unites doors, sliding panels, boiserie panels and storage units. It is extremely adaptable to any type of room for the materials used in construction, but most of all, for its parallel and perpendicular lines marked with metal profiles that define the surface with a contemporary, modern style. The series includes many combinations and different sized modules, for an almost personalised result. The system is divided into modules, and offers several widths and opening styles.*

*Буазери Land - это модульная система, объединяющая двери, раздвижные панели, панели буазери и системы хранения. Она прекрасно адаптируется к любому помещению благодаря используемым материалам и, прежде всего, благодаря параллельным и перпендикулярным линиям, перемежающимся металлическими профилями, которые придают поверхности современный характер. Серия включает многочисленные сочетания и модульные решения с практически индивидуальными размерами. Система подразделена на модули и имеет различные варианты ширины и возможности открытия.*

Land护壁板是一套模块化系统，将门、滑动面板、护壁板和收纳柜整合于一。以极度可适应每种环境的特点展现特色，不但可归功于所采用的材质，更因镶嵌金属条的垂直和并行线条，能以当代时尚与充满现代感的方式完美定义墙面。系列中可有多重搭配与几乎可定制化的多种尺寸的模块。此系统以模块区分，可有不同宽度的搭配并可当作可开的面板使用。



LAND BOISERIE | P.3 ECO-LEATHER 50  
PROFILES | BRIGHT ALUMINIUM





LAND BOISERIE | P.3 ECO-LEATHER 50  
PROFILES | BRIGHT CHAMPAGNE GOLD

VOL. VII - 20

PANELS

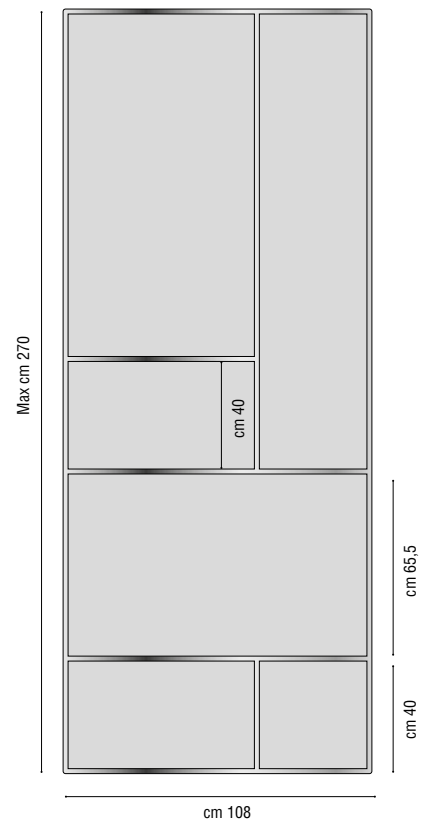
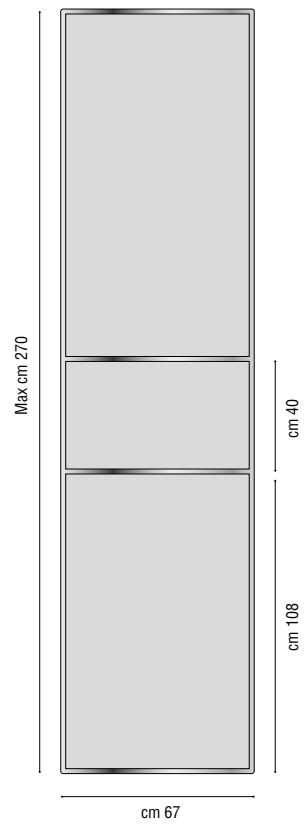
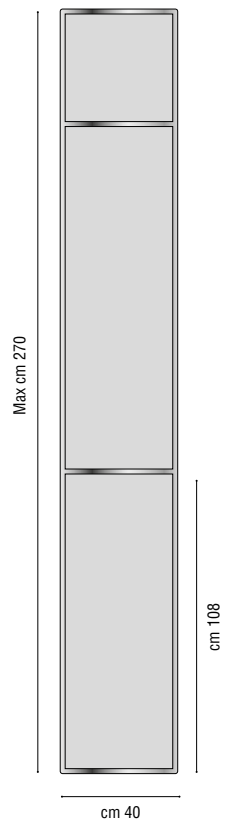

# LAND BOISERIE

*design options*

THE SERIES INCLUDES MANY  
COMBINATIONS AND DIFFERENT  
SIZED MODULES, FOR AN ALMOST  
PERSONALISED RESULT.

La serie comprende molteplici abbinamenti e modularità dalle dimensioni quasi personalizzate. Il sistema è diviso per moduli e si articola in diverse larghezze e possibilità di aperture.

Серия включает многочисленные сочетания и модульные решения с практически индивидуальными размерами. Система подразделена на модули и имеет различные варианты ширины и возможности открытия.

此系统以模块区分，可有不同宽度的搭配并可当作可开的面板使用。





LAND BOISERIE | P.3 TECSUEDE 5311 + BRONZE MIRROR  
PROFILES | MATT SATINED BRONZE





LAND BOISERIE | P.3 TECSUEDE 1043 + NATURAL MIRROR  
PROFILES | MATT SATINED BRONZE

A person's hands are shown holding a pen over a document, with a red grid overlaying the scene. The background features a faint floral pattern. The text is centered in a white, serif font.

THE SYSTEM IS DIVIDED  
INTO MODULES, AND  
OFFERS SEVERAL WIDTHS  
AND OPENING STYLES.



LAND BOISERIE | P.3 TECSUEDE 5105  
PROFILES | BRIGHT CHAMPAGNE GOLD





LAND BOISERIE | P.3 TECSUEDE 5120  
PROFILES | BRIGHT CHAMPAGNE GOLD



EXCLUSIVE AND  
PERSONALISED  
LUXURY MATERIALS.

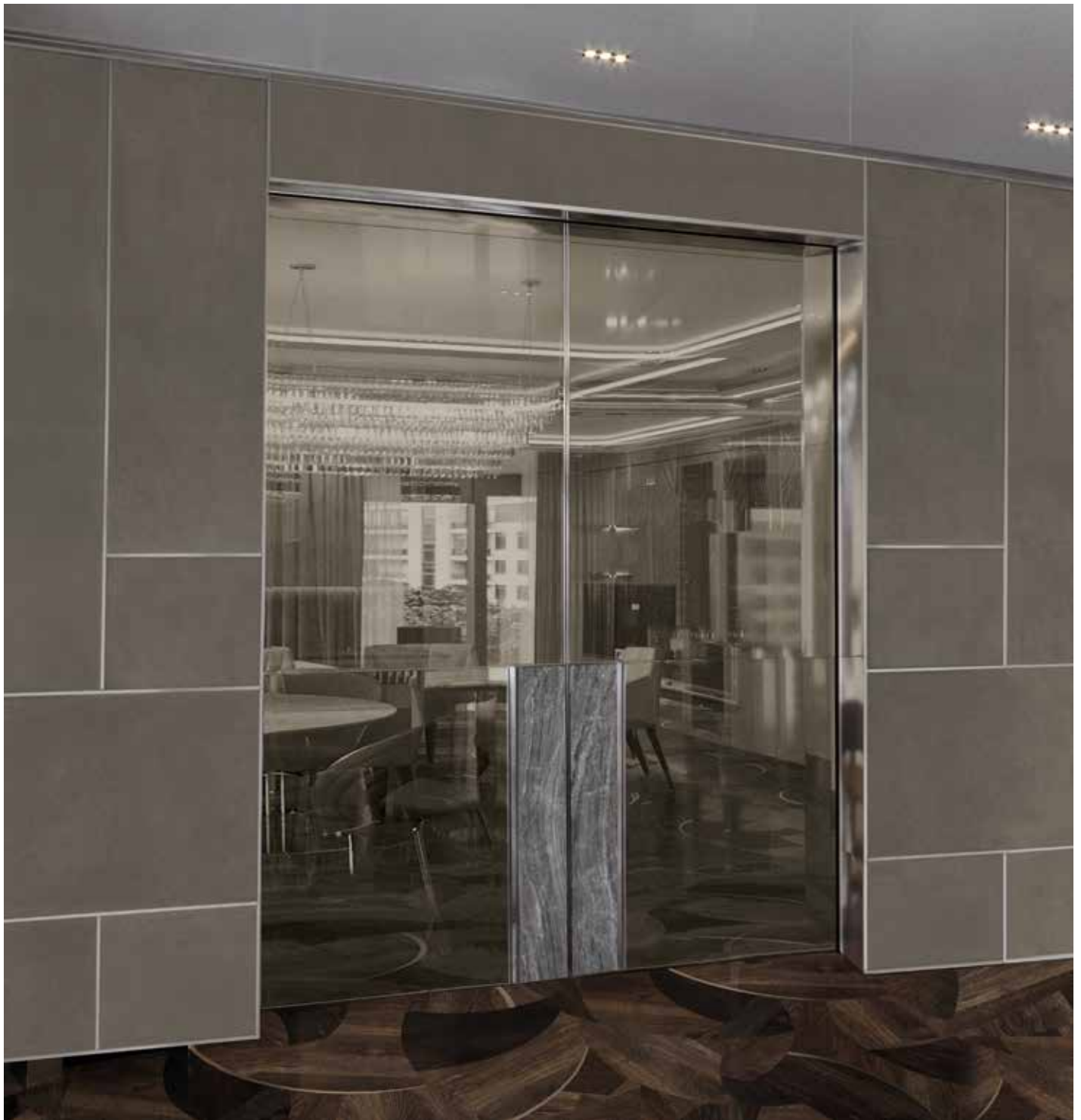

LAND FOREVER | P.3 TECSUEDE 5311  
PROFILES | BRIGHT ALUMINIUM

# TECHNICAL NOTES

## *Land boiserie finishes*

### STRUCTURE

#### Aluminium



MATT SATINED BRONZE

BRIGHT CHAMPAGNE GOLD

BRIGHT DARK BROWN  
ELECTROCOLOUR

BRIGHT ALUMINIUM

MATT DARK BROWN  
ELECTROCOLOUR

#### Matt lacquered aluminium



WHITE

CANAPA

ROPE

TURTLE DOVE

COFFEE

MOKA

PRUN

CEMENT GREY



LEAD GREY

GRANITE

SLATE GREY

NIGHT BLUE

BLACK

### PANEL

#### Mirrors



NATURAL MIRROR

BRONZE MIRROR

SMOKY MIRROR

FROSTED BRONZE MIRROR

FROSTED SMOKY MIRROR

#### Cork



BROWN ON GOLD BASE

BROWN ON SILVER BASE

BRONZE ON SILVER BASE

#### Glossy-matt wood



ERABLE

LIGHT CANALETTO WALNUT

MEDIUM CANALETTO WALNUT

DARK CANALETTO WALNUT

NEWOOD EBONY

EUCALYPTUS

PANEL

*Glossy lacquered tempered glass*



*Tecsuede Cat. P3*



*Eco-leather Cat. P3*

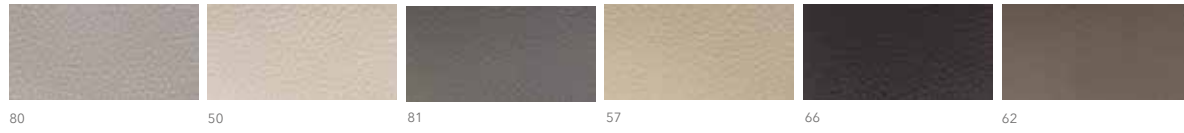

# ENDLESS BOISERIE

designed by Alessandro La Spada | Serie\_340

Il sistema di Boiserie Endless è caratterizzato da molteplici modularità che permettono di arredare l'ambiente attraverso le eleganti finiture che troviamo nella serie lanus. Rilievi e textures delle essenze e della pelle, rendono il «toccare» una piacevole e gratificante sensazione.

*The Boiserie Endless system has many modular features that make it possible to furnish rooms with elegant finishes that we find in the lanus series. Thanks to the relief patterns and textures of the wood and leather, "touching" them conveys a pleasant and rewarding feeling.*

*Система буазери Endless отличается многочисленными модульными решениями, позволяющими украсить интерьер благодаря элегантным отделкам, предлагаемым серией lanus. Рельефы и текстуры древесных пород и кожи делают прикосновение удивительным и приятным ощущением.*

Endless护壁板系统以多重模块化展现特色，可通过lanus系列中的优雅面饰装潢空间。木质与皮料的浮雕与纹理，赋予宜人的「触感」以及令人愉悦的感受。



ENDLESS BOISERIE | P.3 TECSUEDE 5311 + GLOSSY NEWOOD EBONY  
PROFILES | MATT SATINED BRONZE



*custom made piece* / *Sycamore Frisé*



ENDLESS BOISERIE | P.3 TECSUEDE 3103 + GLOSSY SYCAMORE FRISE  
PROFILES | MATT SATINED BRONZE

VOL. VII / 369

PANELS

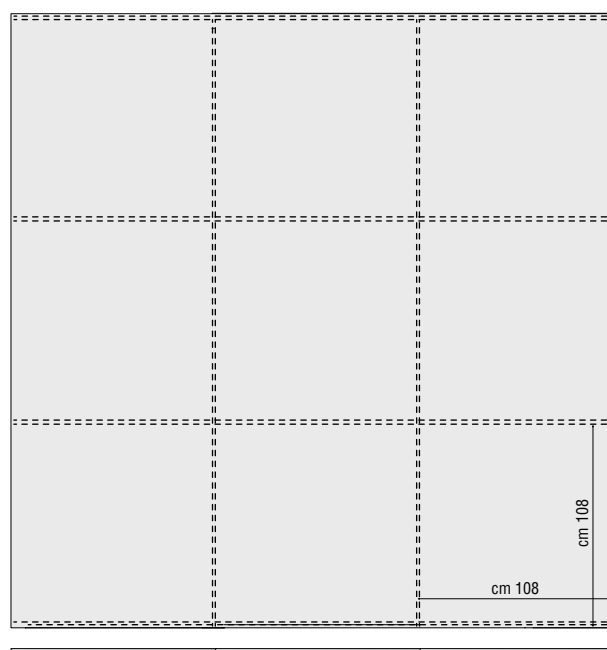
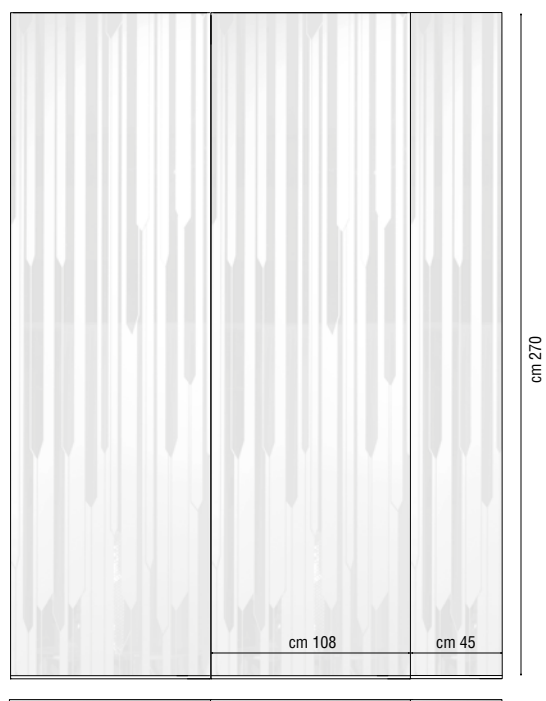
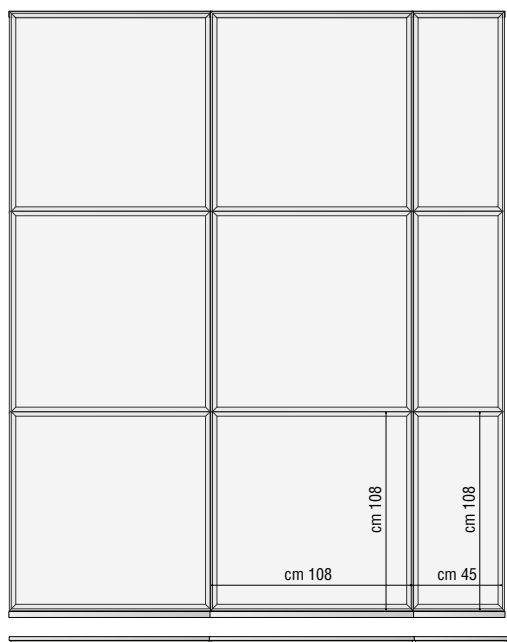

# ENDLESS BOISERIE

*design options*

THE MODULARITY OF THE  
PANELS ALLOWS FOR MAXIMUM  
DESIGN FREEDOM. THE MINIMAL  
STYLE AND WIDE SELECTION  
OF MATERIALS MAKES ENDLESS  
BOISERIE PERFECT FOR ANY ROOM.

La modularità dei pannelli permettono una massima libertà progettuale. Lo stile minimale e l'ampia scelta di materiali rende la boiserie endless perfetta per qualsiasi ambiente.

модульность панелей обеспечивает максимальную свободу при проектировании. благодаря минималистичному стилю и широкому спектру материалов буазери "Endless" идеально вписывается в любой интерьер.

面板的模块化允许最大限度的设计自由。  
极简的风格和丰富的材料选择使 endless 墙面镶板完美适应任何环境。





BOISERIE | ENDLESS  
PANELS | P.3 TECSUEDE 1043 + GLOSSY NEWOOD EBONY



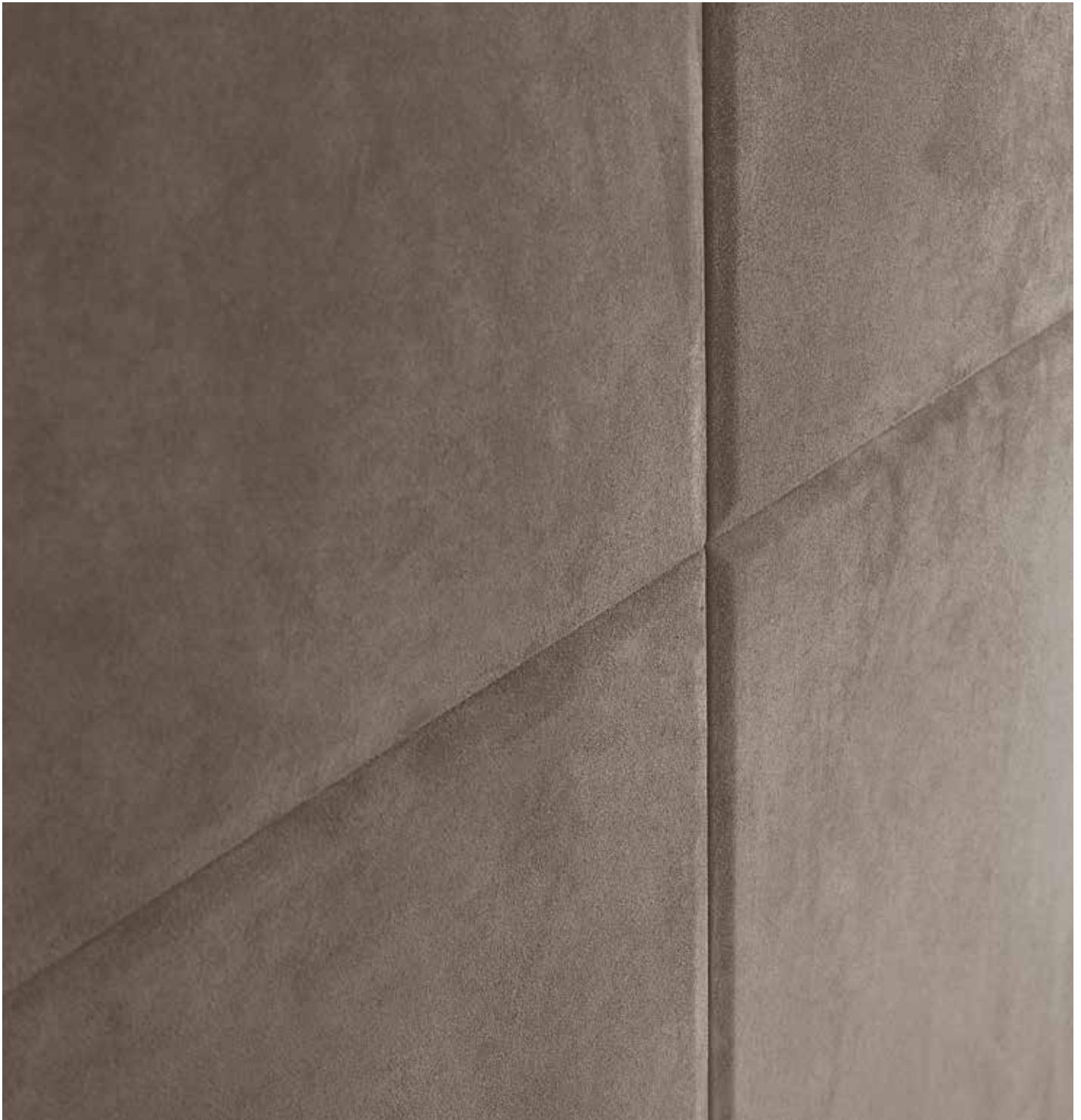

BOISERIE | ENDLESS  
PANELS | P.3 TECSUEDE 5604

EXCLUSIVE PATTERN  
BY ALESSANDRO LA SPADA

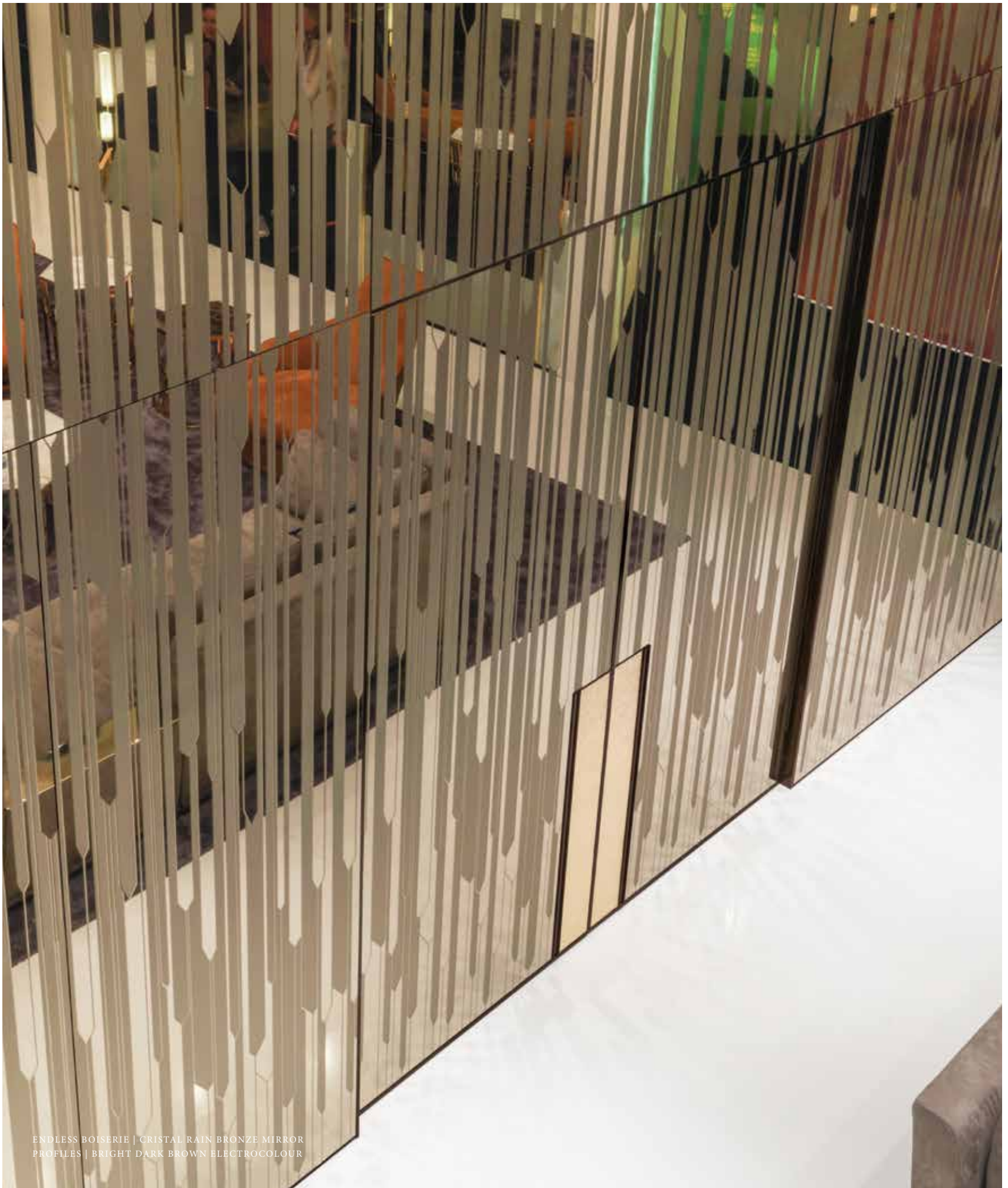

ENDLESS BOISERIE | CRISTAL RAIN BRONZE MIRROR  
PROFILES | BRIGHT DARK BROWN ELECTROCOLOUR



# SLATTED *version*

THE SYSTEM FEATURES A UNIQUE 45-DEGREE OBLIQUE PROCESSING ON A MATT WOOD FINISH, AVAILABLE FOR BOTH FULL AND HALF-HEIGHT PANELS.



FULL PANEL



HALF-HEIGHT PANEL

Il sistema prevede un'esclusiva lavorazione obliqua a 45 gradi su finitura lignea opaca sia per pannello intero che per mezza altezza.

Система предусматривает эксклюзивную обработку с наклоном под 45 градусов на матовой отделке из дерева, выполняемой на панели как в полную, так и в половину высоты.

系统采用独特的 45 度倾斜加工，哑光木质饰面，可用于全高及半高面板。

ERABLE

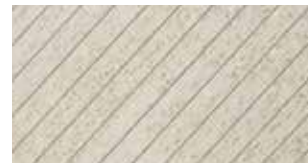

LIGHT CANALETTO WALNUT



MEDIUM CANALETTO WALNUT



DARK CANALETTO WALNUT

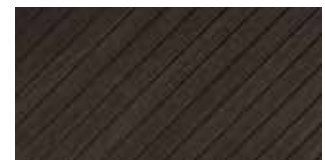



BOISERIE | ENDLESS  
PANEL | MATT SLATTED MEDIUM CANALETTO WALNUT



# TECHNICAL NOTES

## *Endless finishes*

### END TRIMS

#### Aluminium



#### Matt lacquered

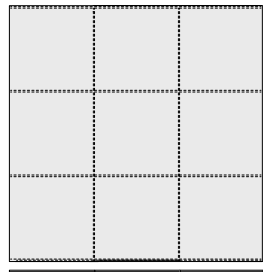
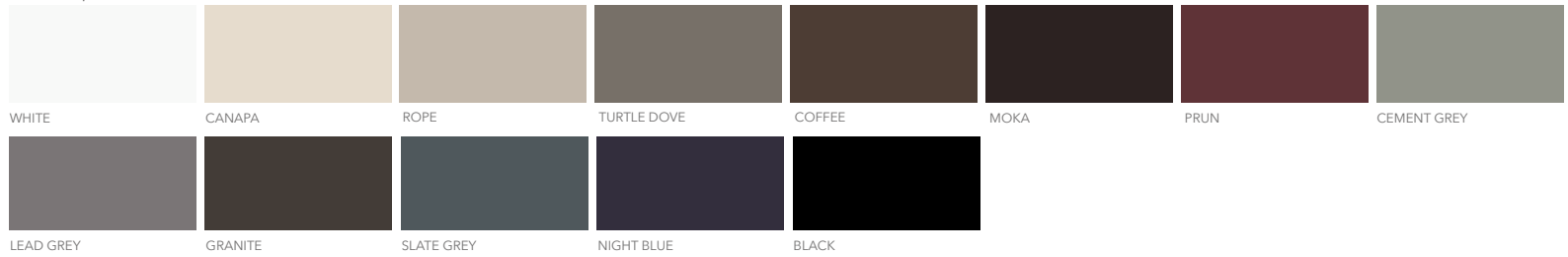

*Covered  
bevelled panel*

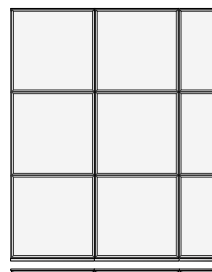

*Covered  
stitched panel*

### PANEL

#### Tecsuede Cat. P3



#### Eco-leather Cat. P3

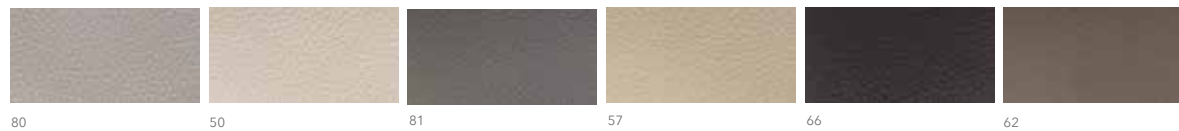

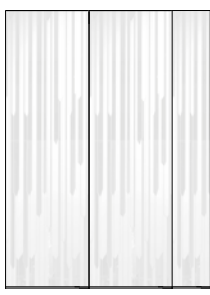

## Full panel

### PANEL

#### Decorated mirrors



CRISTAL RAIN BRONZE

CRISTAL RAIN SMOKY

#### Mirrors



MIRROR

BRONZE MIRROR

FU SMOKY MIRROR

FROSTED BRONZE MIRROR

FROSTED SMOKY MIRROR

#### "Cristal Rain" decorated lacquered glass



WHITE

CANAPA

ROPE

TURTLE DOVE

COFFEE

MOKA

PRUNE

CEMENT GREY



LEAD GREY

GRANITE

SLATE GREY

NIGHT BLUE

BLACK

#### Glossy lacquered tempered glass



WHITE

CANAPA

ROPE

TURTLE DOVE

COFFEE

MOKA

PRUN

CEMENT GREY



LEAD GREY

GRANITE

SLATE GREY

NIGHT BLUE

BLACK

#### Matt/glossy wood



ERABLE

LIGHT CANALETTO  
WALNUT

MEDIUM CANALETTO  
WALNUT

DARK CANALETTO  
WALNUT

NEWOOD EBONY

EUCALYPTUS

#### Matt Slatted wood



ERABLE

LIGHT CANALETTO  
WALNUT

MEDIUM CANALETTO  
WALNUT

DARK CANALETTO  
WALNUT

**Produced by  
LONGHI S.P.A.  
ALL RIGHTS RESERVED**

CONCEPT/  
ART DIRECTION /  
GRAPHIC PROJECT  
**Studio Longhi**

FOTOGRAFIA  
**StudioEleven**  
**Alberto Tagliabue**

FOTORENDERING  
**Methodus**

FOTOLITO  
**CD Cromo**

PRINT  
**Grafiche Boffi - Giussano (MB)**

The rights of the photographs are sole propriety of LONGHI S.P.A.  
Total or partial reproduction in any form is prohibited.

LONGHI S.P.A. reserves the right to make the necessary changes  
and improvements to the products described herein, at any time  
and without notice.

LONGHI Logo, catalogue and advertising images are sole propriety  
of LONGHI S.P.A, henceforth any use of the logo or adaptation  
of images is strictly forbidden without LONGHI S.P.A. prior  
approval; nonetheless, in any case the images must be used in  
such a way that there is no reasonable doubt that those belong to  
LONGHI S.P.A and refer to LONGHI S.P.A products. No part of this  
publication can be reproduced or transmitted in any form or by  
any means, both electronic or mechanical, including photocopying  
and recording, or via any information storage and retrieval system,  
without written permission of the publisher.

**LONGHI**