

Modern
Always

Contemporary
Collections

Vol.2

Knoll







Index

<i>Piero Lissoni</i>	<i>Antonio Citterio</i>	<i>Edward Barber & Jay Osgerby</i>
010 Matic Sofa Collection	140 Klismos Collection by Knoll	172 Pilot Collection for Knoll
040 KN Collection by Knoll KN01, KN02, KN03, KN04, KN05, KN06, KN07	152 Citterio Table Collection	Pilot Chair – Low back Pilot Chair – High back Pilot Ottoman Piton Stool Piton Table
070 Panoramic Sofa Collection	<i>Frank Gehry</i>	180 Edward Barber & Jay Osgerby Sofa Collection
076 Matic Credenzas	162 Frank Gehry Collection	
080 Matic Storage Units	<i>Tobia Scarpa</i>	186 Krusin Collection 016 Krusin Side Tables
084 Gould Sofa Collection	166 Bastiano Sofa Collection	
096 Red Baron by Knoll		
100 Avio Sofa System		
116 Grasshopper Table Collection		
134 Lissoni Outdoor Collection		
		193 Technical info





Knoll has always collaborated with those designers who are most attentive to the stimuli of their age. The world of architecture and design know that they can find in the company their strongest supporter in accomplishing a product derived from a vision. No geographical, regulatory or formal borders exist: wherever there is a designer confident in their own identity and thought, the company has an interlocutor. This is why the Contemporary catalogue marks, with its pieces, a recent chapter of a long history of dialogues with design intelligences.

Depuis toujours, Knoll collabore avec des designers qui sont à l'écoute des impulsions de leur temps. Le monde de l'architecture et du design a conscience que notre entreprise met un point d'honneur à concevoir des produits à partir d'une vision. Aucune barrière formelle, réglementaire ou géographique : nos designers doivent croire en leurs idées et en leur personnalité. Ainsi, le catalogue contemporain ouvre un nouveau chapitre dans notre longue histoire d'échanges avec des génies du design.

Knoll è da sempre in dialogo con i progettisti più attenti alle sollecitazioni della propria epoca. Il mondo dell'architettura e del design sanno di trovare nell'azienda il loro più valido sostenitore nel realizzare un prodotto generato da una visione. Non esistono confini geografici, disciplinari o formali: ovunque risieda un progettista forte della sua identità e del suo pensiero, c'è un interlocutore per l'azienda. Per questo il catalogo Contemporary segna con i suoi pezzi un capitolo recente di una lunga storia di dialogo con le intelligenze progettuali.

Seit jeher arbeitet Knoll mit Designern zusammen, die den Impulsen ihrer Zeit die höchste Aufmerksamkeit widmen. In der Architektur- und Designszene ist bekannt, dass in diesem Unternehmen die stärksten Unterstützer bei der Verwirklichung eines aus einer Vision abgeleiteten Produkts zu finden sind. Es gibt weder geografische, rechtliche noch formale Grenzen: Wo immer es einen Designer gibt, der von seiner eigenen Identität und seinem Denken überzeugt ist, hat das Unternehmen einen Gesprächspartner. Aus diesem Grund schlägt der Contemporary Katalog mit seinen Produkten ein neues Kapitel auf in der langjährigen Geschichte von Dialogen mit Koryphäen des Designs.

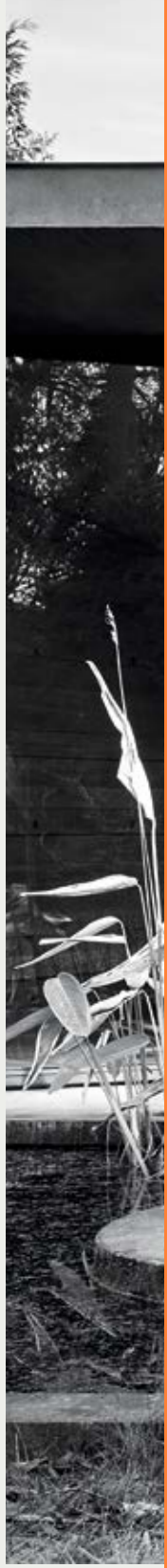

A platform suspended in space, a cross between an island and architecture. An object imagined to float in space and present itself as a universe in and of itself. Matic borrows moves from a frame designed like a building with a strict structural system: pillars, footings, beams, columns, slabs. A high profile technological exercise that decides its own aesthetic destiny, its own form. Very low, ample seating of different dimensions, on which modular arms and backs can be arranged, created to provide structural support.

Una piattaforma sospesa nel vuoto, via di mezzo fra isola e architettura. Un oggetto immaginato per galleggiare nello spazio e disegnarsi come universo a sé. Matic prende le mosse da un telaio pensato come edificio dall'impianto strutturale rigoroso: pilastri, piedi, travi, colonne, solette. Un esercizio tecnologico di alto profilo che determina il proprio destino estetico, la propria forma. Sedute bassissime, ampie, di dimensioni diverse, su cui vivono braccioli e schienali modulari, realizzati per fornire appoggio strutturale.

Une plateforme suspendue, à la croisée d'une île et de l'architecture. Un objet imaginé pour flotter dans l'espace et se présenter tel un univers, en et par lui-même. Matic emprunte au lexique du bâtiment avec un système structural rigoureux: piliers, piétements, poutres, colonnes, dalles. Un exercice technologique de haute volée, pour un objet maître de son destin esthétique, de sa forme. Une assise ample et très basse, déclinée en différentes dimensions, sur laquelle des accoudoirs et des dossiers modulaires peuvent être disposés pour offrir une structure à l'assise.

Eine Plattform schwebend im Raum, ein Zwischending zwischen Insel und Architektur. Ein Objekt treibt scheinbar durch den Raum und mutet an wie ein Universum. Matic geht von einem Rahmen aus, der als Gebäude mit einem strengen strukturellen System entworfen wurde: Säulen, Füße, Balken, Säulen, Platten. Ein anspruchsvoller technologischer Diskurs, der seine eigene ästhetische Richtung und Form bestimmt. Sehr niedrige, großzügige Sitzflächen in verschiedenen Abmessungen, zu denen Arm- und Rückenlehnen als strukturelle Stützen modular hinzugefügt werden können.



Knoll. The Original Design

A muted nature, depending on the finishes, Matic can fit into settings where it disappears or can stand out with its decisive character, but discreetly.

De nature nuancée, selon la finition choisie, Matic peut se fondre dans son environnement ou s'affirmer par son caractère, mais avec discrétion.

Di natura silenziosa, a seconda delle finiture Matic può abitare nell'ambiente fin quasi a scomparire oppure affermarsi per il carattere deciso, ma con discrezione.

In gedeckten Tönen, abhängig von der gewählten Oberfläche, kann Matic entweder mit seiner Umgebung verschmelzen oder mit seinem bestimmten, aber doch diskreten Charakter daraus hervorstechen.

Matic Sofa Collection
Piero Lissoni, 2020

Piero Lissoni — *Matic Sofa Collection*



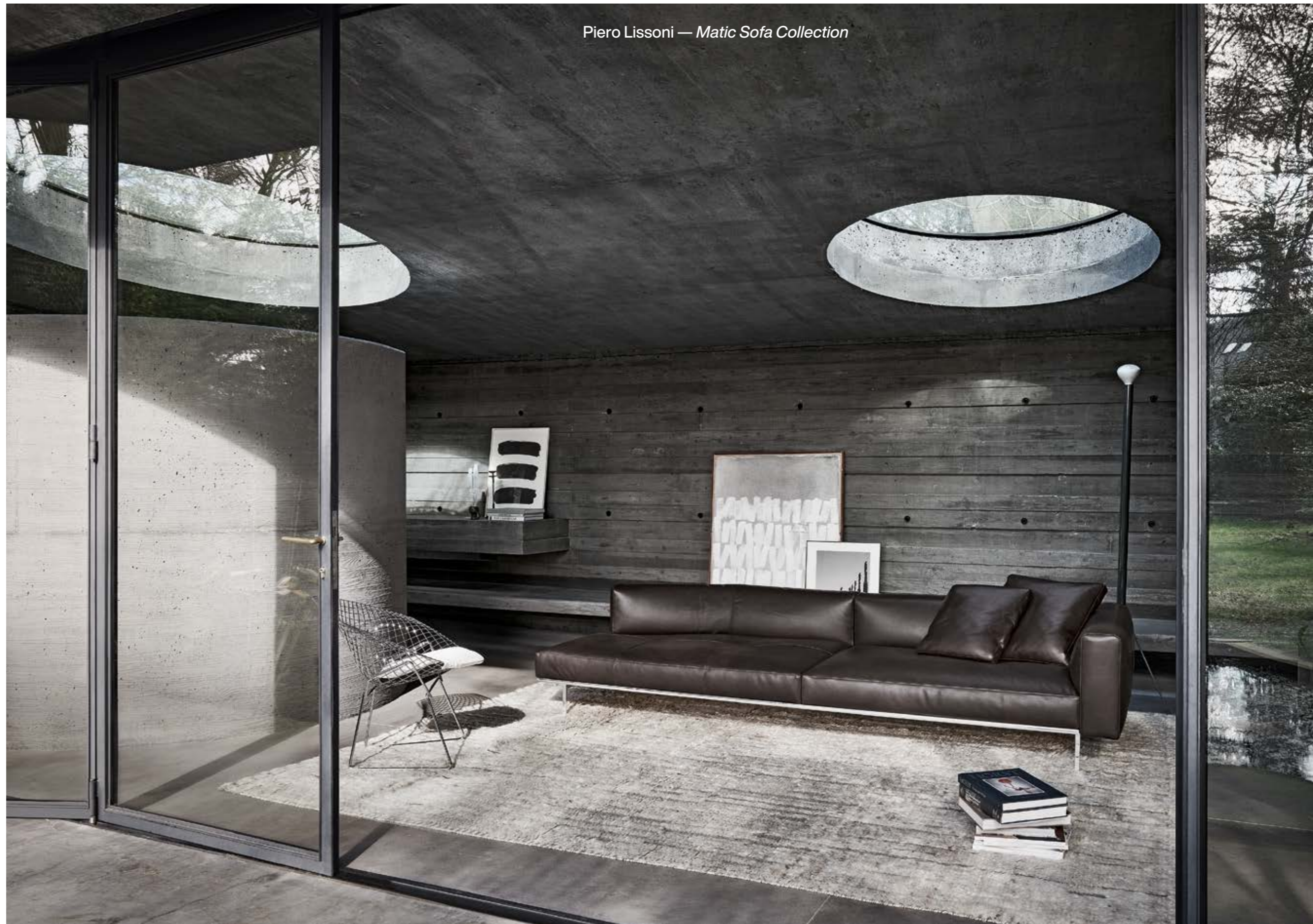

Matic Sofa
Piero Lissoni, 2020

Bertoia Diamond Chair
Harry Bertoia, 1952

Knoll. The Original Design

Matic Chaise Longue
Piero Lissoni, 2020



Piero Lissoni — *Matic Sofa Collection*





Piero Lissoni — *Matic Sofa Collection*

Matic is a collection of modular padded sofas of varying depths, upholstered in either leather or fabric. The chaise longue modules and end peninsula have seats upholstered with evenly-sized squares or with a T-seam, and are equipped with a curved back that moves.

Matic è una collezione di sedute imbottite componibili dalle differenti profondità, rivestibili in pelle o in tessuto. Moduli chaise longue e terminale penisola hanno la seduta rivestita a quadri regolari oppure con cucitura a T, e sono dotati di uno speciale schienale curvo provvisto di movimento.

Matic est une collection de canapés modulables rembourrés, déclinés en plusieurs profondeurs, revêtus soit de cuir ou de tissu. Les modules méridienne et péninsule sont dotés d'assises tapissées en carrés de même taille ou avec une couture en T. Leur dossier, spécialement incurvé, est mobile.

Matic ist eine Kollektion modular aufgebauter Polstersofas, erhältlich in verschiedenen Tiefen und mit Leder- oder Stoffbezug. Die Liege- und Halbinselmodule haben quadratisch oder T-förmig abgesteppte Bezüge und sind mit einer speziellen, geschwungenen und beweglichen Rückenlehne ausgestattet.

Matic Chaise Longue
Piero Lissoni, 2020

Saarinens Low Table
Eero Saarinen, 1957





Knoll. The Original Design

The frontal profile, a key element of the project's aesthetics that determines its capacity to adapt to different settings, can be in aluminium with a shiny finish or charcoal painted finish or covered in fabric or leather. The feet are in aluminium fusion, with either a shiny finish or charcoal painted.

Il profilo frontale, elemento chiave dell'estetica del progetto che ne determina la capacità di adeguarsi ad ambienti diversi, può essere in alluminio finitura lucida o finitura verniciata color manganese oppure rivestito in tessuto o pelle. I piedi sono in fusione di alluminio, finitura lucida oppure verniciata color manganese.

Le profilé avant, élément clé de l'esthétique du projet, détermine la capacité du canapé à s'adapter à différents contextes. Il peut être en aluminium finition brillante, ou peint en coloris charcoal, ou encore revêtu de tissu ou de cuir. Le piétement est en aluminium fusion, finition brillante ou peint en coloris charcoal.

Das Frontprofil – ästhetisches Schlüsselement der Serie und anpassungsfähig an verschiedene Umgebungen – ist aus Aluminium und entweder glänzend poliert oder schwarz gestrichen bzw. mit Stoff oder Leder bezogen. Die Füße sind aus Aluminiumguss, entweder glänzend poliert oder schwarz gestrichen.

Matic Sofa Collection
Piero Lissoni, 2020





Matic Sofa
Piero Lissoni, 2020

Saarinen Low Table
Eero Saarinen, 1957







Matic Sofa
Piero Lissoni, 2020

Saarinen Side Table
Eero Saarinen, 1957



Matic Sofa
Piero Lissoni, 2020





Imagine listening to a conversation capable of shifting from a tale of the past to a tale of the future, seamlessly passing through the present. Something that captures the best frequencies of time and harmonises them. Like KN, the impeccable family of armchairs inspired by just such a movement: conceived of a form that embraces the spirit of modernism and at the same time expresses a sophisticated soul that outlines the future, while designing the present.

Imaginez-vous en train d'écouter une conversation qui évoluerait d'un récit du passé vers celui du futur en passant aisément par le présent. Quelque chose qui capture et harmonise les meilleures fréquences du temps. KN, impeccable collection de fauteuils, s'inspire justement d'un mouvement de ce type : concevoir une forme qui possède l'esprit du modernisme et révèle une âme sophistiquée capable d'esquisser le futur tout en dessinant le présent.

Immaginate di ascoltare una conversazione capace di muoversi dal racconto del passato a quello del futuro, passando senza fatica attraverso il presente. Qualcosa che del tempo colga le frequenze migliori e le armonizzi. Ecco, KN, impeccabile famiglia di poltroncine, si ispira a un movimento del genere: ideare una forma che del modernismo abbia lo spirito e nel contempo esprima un'anima sofisticata che abbozzi il futuro, ma disegnando il presente.

Stellen Sie sich vor, einem Gespräch zuzuhören, das eine Erzählung von der Vergangenheit bis zur Zukunft enthält und dabei mühelos durch die Gegenwart schweift. Etwas, das der Zeit die besten Elemente entnimmt und sie harmonisiert. Das ist KN, eine vortreffliche Familie von Lounge-Sesseln, die sich an einer derartigen Bewegung inspiriert: Eine Form entwerfen, die den Geist der Moderne hat und gleichzeitig eine raffinierte Seele zum Ausdruck bringt, von der die Zukunft konzipiert, aber die Gegenwart gezeichnet wird.

Knoll. The Original Design

KN06 is a chair that features a perfect homogeneity between inside and out, seating and structure. The structure is in fibreglass painted in a glossy white or glossy black colour, or upholstered in fabric or leather. The seat and the back in moulded flexible polyurethane can be upholstered in fabric or leather. The base with four legs in aluminium fusion is in a glossy finish or painted in glossy white or glossy black. In terms of aesthetic value, it is of an uncompromising industrial and technological quality, ideal for a wide variety of contexts and uses, and perfectly offsets dining tables, desks, and mini desks.

La chaise KN06 arbore une homogénéité parfaite entre l'intérieur et l'extérieur, l'assise et sa structure. Cette dernière est en fibre de verre, soit peinte en blanc ou noir finition brillante, soit revêtue de tissu ou de cuir. Le dossier en polyuréthane souple moulé peut être revêtu de tissu ou de cuir. Le piètement composé de quatre pieds en aluminium fusion, se présente soit en finition brillante, soit peint en noir ou blanc, tous deux brillants. En terme de valeur esthétique, ce modèle atteint une qualité industrielle et technologique sans compromis. Adapté à différents contextes et usages, il fera parfaitement écho à une table à manger, un bureau ou un mini-bureau.

KN06 è una sedia caratterizzata da una perfetta omogeneità fra interno ed esterno, seduta e scocca. La scocca è in vetroresina verniciata nei colori bianco lucido o nero lucido, oppure rivestita in tessuto o pelle. La seduta e lo schienale in poliuretano flessibile stampato possono essere rivestiti in tessuto o pelle. La base a quattro gambe in fusione di alluminio è in finitura lucida oppure verniciata nei colori bianco lucido o nero lucido. Per valenza estetica, risultato di una qualità industriale e tecnologica senza compromessi, è adatta a contesti e usi diversi, e vive bene accanto a tavoli da pranzo, scrivanie, scrittoi.

Der KN06 ist ein Stuhl mit perfekter Homogenität zwischen Innerem und Äußerem, zwischen Rahmen und Sitzfläche. Der Rahmen besteht aus Fiberglas in glänzend weiß oder glänzend schwarz oder ist mit Stoff oder Leder bezogen. Der Sitz und die Lehne aus elastischem Polyurethan-Schaum sind ebenfalls mit Stoff oder Leder bezogen. Der Unterbau mit vier Beinen aus Aluminiumguss ist hochglanzpoliert oder weiß bzw. schwarz glänzend gestrichen. Neben seinem ästhetischen Wert ist er von kompromissloser, industrieller und technologischer Qualität. Er ist ideal einsetzbar für eine Vielzahl verschiedener Zwecke und ergänzt perfekt Esstische, Schreibtische und Pulte.

*KN06 Armchair
Piero Lissoni, 2020*

*Saarinens High Table
Eero Saarinen, 1957*

Piero Lissoni — *KN Collection by Knoll*

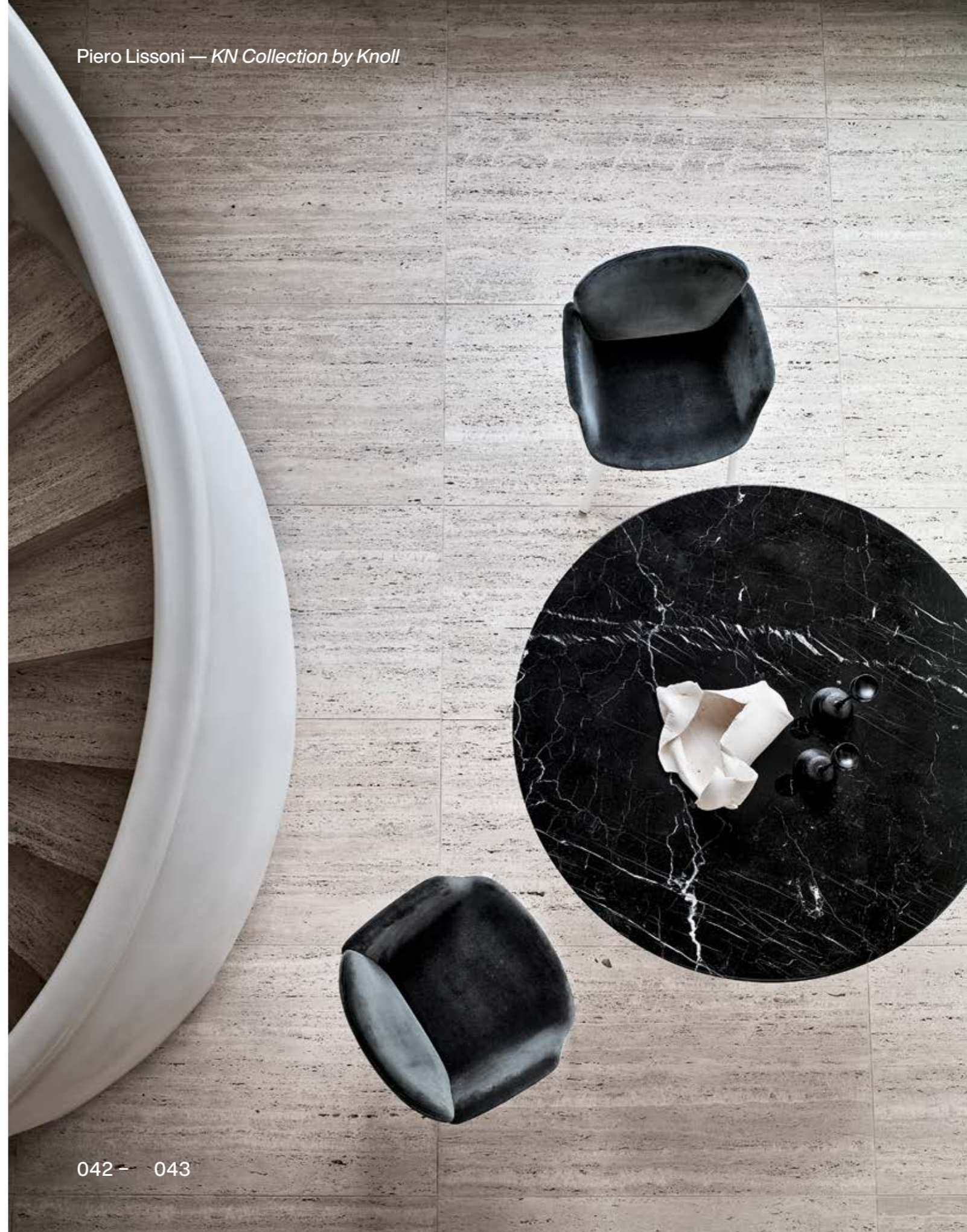





Piero Lissoni — *KN Collection by Knoll*

The design of KN06 connects both inside and out in a uniquely soft and continuous line, resting on four lightweight and slender legs, in aluminium fusion. A clean object, with an outstanding presence, made to last and live in different settings: homes, public buildings, and offices.

Il disegno gentile di KN06 connette interno ed esterno in un'unica linea morbida, continua, appoggiata su quattro gambe leggere e slanciate, in fusione di alluminio. Un oggetto pulito, di chiara presenza, fatto per durare e abitare luoghi diversi: domestici, pubblici, di lavoro.

Le design de KN06 agréable à l'œil, où l'intérieur et l'extérieur se répondent en suivant une même ligne, d'une douceur unique. L'ensemble repose sur quatre pieds élancés, d'une légèreté aérienne, en aluminium fusion. Un objet aux lignes claires, à la présence remarquable, conçu pour durer et s'inscrire dans différents contextes : intérieur, bâtiments publics, bureau.

KN06 hat ein leichtes Design verbindet das Innere und das Äußere in einer unnachahmlich sanften und durchgehenden Linie und ruht schließlich auf vier leichten und schlanken Beinen aus Aluminiumguss. Ein puristisches Objekt mit hervorragender Präsenz für verschiedene Umgebungen: Wohnräume, öffentliche Gebäude und Büros.

KN06 Armchair
Piero Lissoni, 2020

Grasshopper High Table
Piero Lissoni, 2017



Knoll. The Original Design

The formal feature of KN07 chair is the perfect unity of the seating and structure, free of any irregularities. A design that connects both inside and out in a uniquely soft and continuous line, resting on four lightweight and slender legs, column base or swivel base with castors or glides.

La sedia KN07 si distingue grazie alla sua perfetta armonia tra la seduta e la struttura, priva di qualsiasi irregolarità. Un design che collega interno ed esterno in una linea straordinariamente continua e fluida. La seduta poggia su quattro gambe leggere o su base a colonna girevole o regolabile in altezza, con rotelle o pattini.

La chaise KN07 se distingue par l'unité parfaite entre son assise et sa structure. Sa silhouette est fluide, sans la moindre aspérité ; l'intérieur et l'extérieur se confondent pour composer une ligne continue. L'assise repose au choix sur quatre pieds légers et longilignes ou encore sur une base centrale, pivotante ou sur une base centrale réglable en hauteur sur patins ou sur roulettes.

Die formalen Merkmale des KN07 Stuhls bilden die perfekte Einheit von Sitz und Struktur. Ein Design das sowohl die gepolsterte Innen- als auch Außenschale in einer einzigartigen weichen und durchgehenden Linie verbindet und auf vier leichten und schlanken Beinen, einem Säulenfuß oder einer drehbaren Basis mit Rollen oder Gleitern ruht.

*KN07 Chair
Piero Lissoni, 2021*

*KN06 Armchair
Piero Lissoni, 2020*

*Florence Knoll High Table
Florence Knoll, 1961*

Piero Lissoni — *KN Collection by Knoll*





KN04 Lounge Chair
Piero Lissoni, 2019

Saainen Low Tables
Eero Saarinen, 1957

Knoll. The Original Design

Thanks to a particular moulding technology, the KN06 chair is born perfect. The expression of an absolute balance between modernity and tradition. Its form, as the outcome of a sophisticated production process, suggests a half shell gently raised on four lightweight and slender legs, column base or swivel base with castors or glides.

Grâce à une technologie de moulage particulière, le fauteuil KN06 naît parfait. L'expression d'un équilibre absolu entre modernité et tradition. Sa silhouette, résultat d'un processus de production sophistiqué, suggère une demi-coquille supportée délicatement par quatre pieds fins ou par une base centrale, pivotante ou par une base centrale réglable en hauteur sur patins ou sur roulettes.

*KN06 Armchair
Piero Lissoni, 2020*

Grazie a una particolare tecnologia di stampaggio, la sedia KN06 nasce perfetta. È l'espressione di un perfetto equilibrio tra la tradizione e il moderno. La sua forma, risultato di un processo produttivo sofisticato, propone una scocca appoggiata delicatamente su gambe leggere e slanciate o su base a colonna girevole o regolabile in altezza, con rotelle o pattini.

Eine besondere Formtechnik beschert dem Stuhl KN06 seine Perfektion. Der Ausdruck eines absoluten Gleichgewichts zwischen Moderne und Tradition. Die Form ist das Ergebnis eines ausgeklügelten Produktionsprozesses: Eine Halbschale, die sanft auf vier leichten und schlanken Beinen ruht, von einem Säulenfuß oder von einer drehbaren Basis mit Rollen oder Gleitern getragen wird.

Piero Lissoni — *KN Collection by Knoll*



Knoll. The Original Design

KN04 and KN05 represent the evolution of a collection that began in 2018. The KN04 chair, with more compact proportions and ideal for completing domestic corners where relaxation is a style, has been added together with the KN05 settee, with a very distinctive feature. Both have a fixed structure and a shell covered in leather and fabric.

KN04 et KN05 incarnent l'évolution d'un programme lancé en 2018. Le fauteuil KN04 aux proportions plus compactes est idéal pour compléter tous les environnements dédiés à la détente. Il est proposé aux côtés du sofa KN05 au style particulièrement original. Tous deux sont sur piétement fixe sur 4 pieds avec coque d'assise revêtue de tissu ou de cuir.

KN04 Lounge Chair
Piero Lissoni, 2019

KN05 Settee
Piero Lissoni, 2019

Saariinen Low Table
Eero Saarinen, 1957

Platner Side Table
Warren Platner, 1966

KN04 e KN05 rappresentano l'evoluzione di un programma iniziato nel 2018. La poltroncina KN04, dalle proporzioni più compatte è ideale per completare angoli domestici dove il relax è uno stile, viene introdotta assieme al divanetto KN05, caratterizzato da un forte segno contraddistinto. Entrambi con base a quattro gambe hanno rivestimento in tessuto o pelle.

KN04 und KN05 sind die Weiterentwicklung einer Kollektion, die 2018 ihren Anfang nahm. Der Stuhl KN04 zeichnet sich durch kompaktere Abmessungen aus, was ihn zur perfekten Wahl für den Privatbereich macht, in dem die stilvolle Entspannung im Vordergrund steht. Außerdem wurde die Kollektion um die charakteristische Sitzbank KN05 erweitert. Beide Neuzugänge verfügen über eine feste Struktur, für die Schale gibt es Bezüge aus Leder oder Stoff.

Piero Lissoni — KN Collection by Knoll









Piero Lissoni — *KN Collection by Knoll*

KN01 is a cosy, compact, low-back lounge chair. Its balanced proportions deliver a compact footprint and inviting form ideal for modern living, meeting and community spaces.

KN01 è una poltroncina estremamente accogliente, compatta e dallo schienale basso. Le sue proporzioni e dimensioni sono ideali per gli ambienti residenziali moderni ma anche per aree d'attesa e spazi comuni.

KN01 est un fauteuil confortable, compact et à dossier bas. Ses proportions équilibrées offrent une empreinte compacte et une forme invitante, idéale pour les espaces de vie, de réunion et les lieux publics.

KN01 ist ein gemütlicher, kompakter Sessel mit niedriger Rückenlehne. Seine ausgewogenen Proportionen bieten eine kompakte Grundfläche und eine einladende Form, ideal für moderne Wohn-, Besprechungs- und Gemeinschaftsräume.

KN01 Lounge Chair
Piero Lissoni, 2018

Platner Side Table
Warren Platner, 1966





Piero Lissoni — *KN Collection by Knoll*

KN07 is a chair without armrests that stands out for its poised design that joins the inner and outer surfaces in a single, soft, fluid line. Covered in fabric or leather, the KN07 is an ideal choice to complete corners in the home devoted to work or study.

KN07 è una sedia senza braccioli che si distingue per un design minimalista che unisce interno ed esterno in un'unica linea morbida e fluida. Rivestita in tessuto o pelle, KN07 è adatta per completare angoli domestici dedicati al lavoro come lo studio di casa.

KN07 est une chaise sans accoudoirs au design empreint de douceur qui réunit intérieur et extérieur au sein d'une seule ligne fluide. Revêtue de tissu ou de cuir, la chaise KN07 est idéale pour étudier ou travailler à la maison.

KN07 ist ein Stuhl, der sich durch ein anmutiges Design auszeichnet, das Innen- und Außenbereich in einer einzigen weichen und fließenden Linie verbindet. Mit Stoff- oder Lederpolsterung versehen, eignet sich der KN07 sowohl für den Arbeitsplatz sowie für den privaten Wohnraum.

KN07 Chair
Piero Lissoni, 2021

Florence Knoll Mini Desk
Florence Knoll, 1961

Tulip Stool
Eero Saarinen, 1957



Knoll. The Original Design

KN02 is an armchair with a high back, perfect for prolonged sitting and comes with a headrest and return mechanism and includes a tilt control that allows the chair to be inclined to an almost perfect angle for resting. The KN03 footrest completes the set.

KN02 est un fauteuil idéal pour une assise prolongée, est doté d'un appui-tête et d'un mécanisme à retour amorti qui permet d'incliner le fauteuil à un angle idéal pour la détente. Le fauteuil est complété du repose-pieds KN03.

KN02 è una poltrona con schienale alto, ideale per sedute prolungate. E' dotata di poggiatesta e di un comando, con ritorno ammortizzato, che la rende inclinabile dalla posizione eretta a un'angolazione perfetta per il riposo. Il poggiapiedi KN03 la completa.

KN02 ist ideal für längeres Sitzen. Der Sessel hat eine Kopfstütze und einen Mechanismus mit gedämpfter Rückfederung, mit dem die Rückenlehne von der geraden Sitzposition bis zu einer Winkelstellung geneigt werden kann, die perfekt zum Ausruhen ist. Zur Vervollständigung gibt es die Fußstütze KN03.

*KN02 Swivel and Reclining High Back Lounge Chair
Piero Lissoni, 2018*

*KN03 Ottoman
Piero Lissoni, 2018*

Piero Lissoni — *KN Collection by Knoll*





Piero Lissoni — *Panoramic Sofa Collection*

Panoramic can be a vis-à-vis, a superb chaise longue, an island, bench, dormeuse and, of course, a comfortable sofa. Lending it this variable nature are the three different backrests, movable and repositionable, to be attached along the perimeter of the tubular steel structure painted in charcoal or a shiny finish. Upholstery is available in either fabric or leather.

Panoramic, c'est un canapé vis-à-vis, c'est une chaise longue aux proportions généreuses, un îlot, cela peut être un banc, une dormeuse ou tout simplement un canapé confortable. Trois différents dossiers, amovibles et repositionnables lui confèrent sa nature changeante. Ils s'accrochent le long du périmètre de la structure tubulaire en acier, peinte en coloris charcoal ou dans un fini brillant. Le revêtement est disponible en tissu ou en cuir.

Panoramic può essere seduta vis-à-vis, super chaise longue, isola, panca, dormeuse e, naturalmente, confortevole divano. A conferirgli questa natura mutevole sono i tre differenti schienali, mobili e riposizionabili, da agganciare lungo il perimetro della struttura tubolare in acciaio, verniciata color manganese o in finitura brillante. Il rivestimento è disponibile in tessuto o in pelle.

Auf Panoramic kann man sich gegenüber sitzen, es ist eine Super-Chaiselongue, eine Insel, eine Bank, eine Dormeuse, aber auch ein bequemes Sofa. Diese Wandelbarkeit wird durch die drei beweglichen und verstellbaren Rückenlehnen erreicht, die entlang der anthrazitfarbenen oder glänzend lackierten Stahlrohrstruktur befestigt werden. Der Bezug ist in Stoff oder Leder erhältlich.





Piero Lissoni — *Panoramic Sofa Collection*

Panoramic Sofa
Piero Lissoni, 2022

Panoramic Low Table
Piero Lissoni, 2022

Saainen Low Table
Eero Saarinen, 1957





Piero Lissoni — *Matic Credenzas*

More than a system of containers: an ensemble of architecture. The quality of the technology and of the project that created them results in four volumes that are lean, exact and, at the same time, highly robust, durable. Four objects meant for multiple uses: a floor-standing credenza and another on feet with two drawers; a square storage with four opposing drawers; a floorstanding open storage.

Plus qu'un système de meubles de rangement, une collection d'architecture. La qualité de la technologie et du design dont ils résultent a permis de créer quatre volumes secs, précis et, dans le même temps, d'une grande robustesse et longévité. Quatre objets destinés à des usages multiples : un buffet au sol et un buffet sur pieds avec deux tiroirs ; un rangement au sol et un rangement sur pieds avec deux tiroirs ; un meuble rangement au sol avec quatre tiroirs opposés, un autre ouvert, au sol.

Più che un sistema di contenitori, una collezione di architetture. La qualità della tecnologia e del progetto da cui nascono dà luogo a quattro volumi asciutti, esatti e, al contempo, robustissimi, longevi. Quattro oggetti destinati a usi molteplici: una credenza a terra e una su piedini con due cassetti; un contenitore a terra con quattro cassetti contrapposti; un contenitore a terra, aperto.

Matic ist mehr als ein Containersystem – eine Kollektion architektonischer Formen. Dank hoher technologischer und gestalterischer Standards weist es vier Objekte auf, die feinsinnig und präzise, dabei gleichzeitig robust und langlebig sind. Die Objekte bieten Stauraum für vielfältige Verwendungszwecke: Dazu gehören ein bodenstehendes Sideboard und ein auf Füßen montiertes mit zwei Schubladen, ein Standcontainer mit vier gegenüberliegenden Schubladen sowie ein offener Standcontainer.



Piero Lissoni — *Matic Credenzas*

Matic Credenza
Piero Lissoni, 2022





Piero Lissoni — *Matic Storage Units*

Four metallic reinforcements so thin they seem traced in lines of extreme lightness. Four large boxes with shapes so pure they would appear designed to house a void. From this perhaps springs the idea of a large open formwork, surmounted by a movable wooden platter that leaves the interior's bare elegance open to view. The closed containers' marble covers do not alter the overall lightness, and are available in either Statuarietto, Marquina Black or Grey.

Quatre armatures métalliques très fines dessinent des lignes d'une extrême légèreté tandis que quatre grandes boîtes aux formes très pures semblent avoir été conçues pour abriter le vide. De là peut-être est née l'idée d'un grand coffrage ouvert, surmonté d'un plateau mobile en bois laissant voir l'élégance épurée de l'intérieur. Les revêtements en marbre des rangements fermés n'altèrent pas la légèreté de l'ensemble et sont disponibles en trois versions au choix : Statuarietto, Nero Marquina ou Grey.

Sono quattro armature metalliche dagli spessori così ridotti da disegnarsi in linee di estrema leggerezza. Quattro grandi scatole dalle forme così pure che parrebbero pensate per fare da casa al vuoto. Forse da qui nasce l'idea di un grande cassero aperto, sormontato da un vassoio mobile in legno che lasci a vista la nuda eleganza dell'interno. Le coperture in marmo dei contenitori chiusi non alterano la levità dell'insieme e sono disponibili, a scelta, in Statuarietto, Nero Marquina o Grey.

Zartgliedrige Metallgestelle verleihen den Möbeln eine besondere Feingliedrigkeit. Die vier großen Kästen präsentieren sich in so reinen Formen, als ob sie der Leere ein Zuhause bieten. Mit einem flexibel einsetzbaren Holztablett wirkt Matic wie eine große, offene Schalung, die schlichte Eleganz des Innenraums bleibt sichtbar. Auch die Marmorabdeckungen in den Farben Statuarietto, Nero Marquina und Grau auf den geschlossenen Containern beeinträchtigen nicht die Leichtigkeit ihres Erscheinungsbildes.

Knoll. The Original Design

Matic Square Storage Unit
Piero Lissoni, 2022



Modern Always®

Piero Lissoni — *Matic Storage Units*



082 - 083



Piero Lissoni — *Gould Sofa Collection*

A collection of upholstered furniture based on a more relaxed, informal way of sitting, in a spirit of classic-contemporary taste, relying on ample proportions and large cushions to ensure extraordinary comfort. Accommodating with its more accentuated depth, Gould is perfect in modern spaces with a minimal-chic tone, refined and informal at the same time, in tune with the natural desire for relaxation.

Une collection de canapés, inspirée d'une assise plus décontractée et informelle, dans un esprit classique-contemporain, qui s'appuie sur d'amples proportions et des coussins larges pour un confort extraordinaire. Accueillant grâce à sa profondeur accentuée, Gould se prête idéalement aux espaces à la fois modernes et minimalistes chics, aussi raffinés qu'informels, en phase avec un désir naturel de relaxation.

Una collezione di imbottiti pensata per favorire una seduta più rilassata ed informale che si caratterizza per un'anima dal gusto classico contemporaneo e per le proporzioni generose grazie alle ampie cuscinature e il grande comfort. Accogliente nella profondità più accentuata, Gould è perfetto per essere inserito in ambienti moderni di gusto minimal-chic, raffinato ed informale al tempo stesso, pensato per assecondare la naturale voglia di relax.

Eine Kollektion von Polstermöbeln, die auf einer entspannteren, lässigen Art des Sitzens gemäß dem klassisch-zeitgenössischen Geschmack basiert und auf großzügige Proportionen und große Kissen setzt, um maximalen Komfort zu gewährleisten. Gould passt sich mit seiner akzentuierten Tiefe perfekt modernen Räumen im Stil des Minimal Chic an, raffiniert und zwanglos zugleich, im Einklang mit dem natürlichen Wunsch nach Entspannung.







Knoll. The Original Design

Gould is a large, extra large and extra-extra large sofa and can have different configurations with the addition of the chaise longue module, in perfect Knoll style, to create a comfortable and elegant product. Piero Lissoni has come up with a sofa full of technological and sartorial content, reflecting the research and craftsmanship that have always been key factors in the company's genetic code. Relaxing on a Gould sofa, one immediately has a pleasant sensation of comfort.

Le canapé Gould se décline en format L, XL et XXL. Modulable, il multiplie les configurations et peut être associé à une méridienne. Ce produit aussi confortable qu'élégant épouse parfaitement le style de Knoll. Son créateur, Piero Lissoni, a conjugué technologie et habillement d'excellence, reflétant l'esprit de recherche et d'artisanat qui façonne depuis toujours l'ADN de l'entreprise. Il suffit de se détendre dans un canapé Gould pour ressentir immédiatement une agréable sensation de confort.

*Gould Sofa
Piero Lissoni, 2019*

La collezione è composta da un divano large, extra large o extra-extra large e sono possibili diverse configurazioni grazie all'aggiunta della chaise longue. In perfetto stile Knoll, con l'intento di creare un prodotto confortevole ed elegante, Lissoni progetta un divano ricco di contenuti tecnologici e sartoriali a dimostrazione di come ricerca e artigianalità costituiscano da sempre il patrimonio genetico dell'azienda. Accomodandosi sul divano Gould si avverte immediatamente una piacevole sensazione di comfort.

Die Kollektion Gould besteht aus großen, X-Large- und XX-Large-Sofas und ist in verschiedenen Konfigurationen mit dem Zusatz des Chaiselongue-Moduls erhältlich - ein komfortables und elegantes Produkt im perfekten Stil von Knoll. Piero Lissoni hat ein Sofa mit vielen funktionalen und eleganten Elementen entworfen, das die Forschung und das Handwerk widerspiegelt, die seit jeher Schlüsselfaktoren in der DNA des Unternehmens sind. Bei der Entspannung auf einem Sofa der Kollektion Gould kann man unmittelbar ein angenehmes Gefühl von Komfort verspüren.

Piero Lissoni — *Gould Sofa Collection*







Piero Lissoni — *Red Baron by Knoll*

Red Baron is a subtle presence, capable of living in a variety of spaces and atmospheres. Its particular characteristic is the ultra thin shelves in aluminium. Conceived as a perfectly contemporary object, it dialogues easily with the whole Knoll collection, classic or new.

Red Baron est une présence légère, capable de vivre dans des espaces et des ambiances diverses. Elle se distingue par l'épaisseur de ses étagères réduites à de fines feuilles de métal avec finition en aluminium. En tant qu'objet parfaitement contemporain, Red Baron sait dialoguer avec toutes les pièces de la collection Knoll, des plus classiques aux plus nouvelles.

Red Baron è una presenza lieve, capace di vivere in spazi e atmosfere diversi. Sua caratteristica peculiare è lo spessore dei piani, ridotti a sottili fogli di metallo finiti in alluminio. Pensata come oggetto perfettamente contemporaneo, sa dialogare con tutti i pezzi della collezione Knoll, sia classici che contemporanei.

Red Baron hat eine leichte Präsenz, die in verschiedenen Räumen und Atmosphären leben kann. Seine Besonderheit ist die Dimension der Borde, die auf dünne Bleche aus edlem Aluminium reduziert sind. Als perfekt zeitgenössisches Objekt konzipiert, passt das Regal zu allen Stücken der Knoll-Kollektion.





Piero Lissoni — *Avio Sofa System*

Avio is a contemporary and versatile sofa system that re-interprets and makes better use of any space. It is ideal for those who appreciate elegant design that epitomises a comfortable, relaxed lifestyle.

Avio est un système de canapé modulable et contemporain qui permet de ré-interpréter et d'optimiser l'espace. Expression d'un style de vie confortable et décontracté, il séduira les amateurs de design fort et élégant.

Avio è un sistema di divani contemporaneo e versatile che permette di reinterpretare e sfruttare ogni tipo di spazio, ideale per chi ama un design solido ed elegante, espressione di uno stile di vita comodo e rilassato.

Das Sofa Avio ist ein zeitgemäßes und vielseitiges konstruktives Sofasystem, um alle Arten von Räumen neu zu interpretieren und zu nutzen. Es ist ideal für all diejenigen, die solides, elegantes Design schätzen, das Ausdrucksform eines gemütlichen und entspannten Lebensstils ist.

















If this table could be described with just two words, they would be flared and lightweight, and indeed, Grasshopper borrows its name from the animal that has six precision tools for legs. Above them sits a top that is so thin that it looks able to lift up and take to the air. An object that is so weightless and compact that it works perfectly with all the chairs of the Knoll range. And then I wanted it to have the height of a classic table, just a little lower than those of today, a few centimeters less to promote refinement and conviviality around the table. Grasshopper also includes a family of low tables conceived as a minimal planetary system.

S'il fallait décrire en deux mots cette table, ce serait pattes et ultra légèreté. En effet, Grasshopper emprunte le nom de cet insecte dont les six pattes sont autant d'outils de précision. Elles forment un socle soutenant un plateau d'une telle finesse qu'il donne l'impression de flotter. Aérien et peu encombrant, ce meuble s'harmonise parfaitement avec tous les sièges du catalogue Knoll. J'ai aussi eu envie d'abaisser légèrement la hauteur du plateau : quelques centimètres en moins pour plus d'élégance et de convivialité autour de la table. Grasshopper se décline aussi dans une collection de tables basses.

Grasshopper è un tavolo stabile e leggerissimo. Mutua infatti il nome dall'animale che per gambe ha sei strumenti di precisione. Sopra di loro appoggia un piano sottile. Aereo e poco ingombrante, Grasshopper vive bene con tutte le sedie del catalogo Knoll. Ha l'altezza dei tavoli classici, appena più bassi di quelli di oggi: qualche centimetro in meno per un'invidiabile educazione nello stare a tavola. Grasshopper si declina anche in una famiglia di tavoli bassi.

Den Tisch Grasshopper kann man mit zwei Worten umschreiben: standfest und federleicht. Der Name – angelehnt an das Insekt mit sechs Beinen wie Präzisionsinstrumente – ist Programm. Die dünne Tischplatte wirkt, als könne man sie ohne große Anstrengung in die Luft heben. Grasshopper ist ein leichtfüßiges und gleichzeitig kompaktes Objekt, das sich wunderbar mit allen Sitzmöbeln der Knoll-Kollektion kombinieren lässt. Die Tischreihe umfasst sowohl Ess- als auch Couchtischvarianten in verschiedenen Höhen.

Knoll. The Original Design

The Grasshopper table tops are available in glass, heat-treated woods and rare and exquisite stone.

La table Grasshopper est proposée avec des plateaux en verre, en bois traité thermiquement et en pierre originale de toute beauté.

I piani del tavolo Grasshopper sono disponibili in cristallo, legno e marmi pregiati e rari.

Die Tischplatten der Grasshopper-Kollektion sind in Glas, hitzebehandeltem Holz und in hochwertigem Marmor erhältlich.

Grasshopper High Table
Piero Lissoni, 2017

Piero Lissoni — *Grasshopper Table Collection*





Knoll. The Original Design

Each element of the Grasshopper table expresses the value of Knoll craftsmanship, evidenced in the working of raw materials of the highest quality, and careful and passionate detailing that confers a special charm to these extremely versatile tables.

Ogni singolo elemento del tavolo Grasshopper esprime il valore della maestria artigianale di Knoll, che trova evidenza nella lavorazione di materie prime di assoluta qualità, con particolari realizzati con cura e passione, che garantiscono un fascino particolare a questi tavoli estremamente versatili.

Chaque élément de la table Grasshopper reflète l'immense savoir-faire artisanal de Knoll, qui s'exprime dans le travail des matières premières de très grande qualité ainsi que dans des détails conçus avec soin et passion, pour conférer un charme très particulier à ces tables extrêmement polyvalentes.

Jedes einzelne Element des Grasshopper Tisches repräsentiert die Wertigkeit der Handwerkskunst Knolls, die in der Verarbeitung der ausgesuchten Rohstoffe und den mit besonderer Sorgfalt und Leidenschaft realisierten Details zum Ausdruck kommt.

Grasshopper High Table
Piero Lissoni, 2017



Piero Lissoni — *Grasshopper Table Collection*

Knoll. The Original Design

The round or rectangular surfaces of the Grasshopper table stand out for their slimness, while the structure is formed by very thin, high-performance cast steel parts.

Le superfici tonde o rettangolari del tavolo Grasshopper sono caratterizzate da spessori estremamente sottili mentre la esile struttura è realizzata con elementi in acciaio ad elevate prestazioni.

Les surfaces rondes ou rectangulaires de la table Grasshopper se distinguent par leurs lignes élancées, tandis que la structure se compose d'éléments ultra fins en acier haute performance.

Die runden oder rechteckigen Oberflächen von Grasshopper Tisch wirken besonders grazil, während die Konstruktion aus schlanken, gusseisernen Elementen besteht.

Grasshopper High Table
Piero Lissoni, 2017

Tulip Chairs
Eero Saarinen, 1957





Grasshopper High Table
Piero Lissoni, 2017

Tulip Chairs, Armchairs, Stool
Eero Saarinen, 1957







Piero Lissoni — *Grasshopper Table Collection*

The elegance of the Grasshopper table is derived from its distinct combination of slender surfaces in soft organic forms and a high-performance steel structure. The tabletop's thin edge evokes a feeling of weightlessness and adds an equally refined touch to the home or office.

L'eleganza del tavolo Grasshopper deriva dalla sua particolare combinazione tra la superficie del piano e le forme organiche morbide insieme a una struttura in acciaio molto performante. Il bordo sottile del piano evoca una sensazione di leggerezza e aggiunge un tocco raffinato sia alla casa che all'ufficio.

L'élégance de la table Grasshopper découle de la combinaison entre son plateau fin aux formes organiques douces, et sa structure en acier haute performance. Le chant biseauté du plateau lui donne de la légèreté et apporte une touche de raffinement.

Die Eleganz des Grasshopper-Tisches beruht auf seiner ausgeprägten Kombination aus schlanken Oberflächen in weichen organischen Formen und einer Hochleistungsstahlstruktur. Die dünne Kante der Tischplatte vermittelt ein Gefühl der Schwerelosigkeit und verleiht dem Zuhause oder dem Büro eine ebenso raffinierte Note.

Grasshopper High Table
Piero Lissoni, 2017



Piero Lissoni — *Outdoor Collection*

Conceived to harmonize in form and spirit with the collection of outdoor furniture created by Richard Schultz in 1966, at the behest of Florence Knoll, and considered the first example of modern exterior design, Lissoni Outdoor Collection was born classic from day one. It can take the form of a lounge chair or a three-seat sofa, cozy and comfortable, with ample cushions.

Conçue pour dialoguer dans la forme et l'esprit avec la collection de mobilier d'extérieur dessinée en 1966 par Richard Schultz à la demande de Florence Knoll, considérée comme le premier projet moderniste de mobilier d'extérieur, la Lissoni Outdoor Collection est née classique. Elle peut se décliner en fauteuil, en canapé deux ou trois places, douillet, confortable avec de généreux coussins.

Progettata per accordarsi nelle forme e nello spirito alla collezione di arredi da esterni disegnata da Richard Schultz nel 1966, su richiesta di Florence Knoll, considerata il primo progetto moderno di arredi outdoor, Lissoni Outdoor Collection è nata classica. Può declinarsi in poltrona o in divano a tre posti, accogliente e confortevole, dagli ampi cuscini.

Die Lissoni Outdoor Collection folgt in Form und Geist der von Richard Schultz 1966 auf Wunsch von Florence Knoll entworfenen Outdoor-Möbelkollektion, die als das erste moderne Outdoor-Möbelprojekt gilt. Die Kollektion ist extrem vielseitig. Sie zeigt sich als Sessel oder als dreisitziges Sofa, gemütlich und bequem, mit voluminösen Kissen. Mit nur zwei Sitzkissen wird es zu einem asymmetrischen Zweisitzer-Sofa mit integriertem Ablagetisch.



Knoll. The Original Design

Lissoni Outdoor Armchair
Piero Lissoni, 2023

Lissoni Outdoor Stool
Piero Lissoni, 2023

Saariinen Low Tables
Eero Saarinen, 1957

Lissoni Outdoor Three-Seat Sofa
Piero Lissoni, 2023

Petal® Table
Richard Schultz, 1966



Piero Lissoni — *Outdoor Collection*





Centred on variety of forms and materials, the new collection designed by Citterio combines, in chairs, lounge chairs and tables, the natural image of wood, the finesse of cotton weave, the reflections of steel and the structures' dynamic shapes. Pieces that are like architecture, which fit in perfectly with the design of historic items such as the Pedestal coffee table by Eero Saarinen or Florence Knoll's more classic sofa.

Reposant sur la variété des formes et des matériaux, la nouvelle collection de chaises, de fauteuils et de tables conçue par Citterio conjugue l'image naturelle du bois, la finesse du tissage de coton, les reflets de l'acier et les formes dynamiques des structures. Perçus comme de l'architecture, les meubles complètent à la perfection le design des pièces historiques, telles que la table basse Pedestal d'Eero Saarinen ou le canapé plus classique de Florence Knoll.

Incentrata sulla varietà di forme e materiali, la nuova collezione disegnata da Citterio combina in sedie, poltroncine e tavoli l'immagine naturale del legno, la finezza dell'intreccio di cotone, i riflessi dell'acciaio e le forme dinamiche delle strutture. Mobili come architetture, che si integrano perfettamente con il design di pezzi storici, quali il tavolino Pedestal di Eero Saarinen o il più classico divano di Florence Knoll.

Die neue von Citterio entworfene Kollektion konzentriert sich auf die Vielfalt der Formen und Materialien und kombiniert in Stühlen, Sesseln und Tischen das natürliche Erscheinungsbild von Holz, die Feinheit von Baumwollgeflecht, die Reflexe von Stahl und die dynamischen Formen der Strukturen: Es handelt sich um architektonisch anmutende Stücke, die das Design historischer Entwürfe wie des Pedestal-Tischs von Eero Saarinen oder des eher klassischen Sofas von Florence Knoll perfekt ergänzen.



Knoll. The Original Design

Klismos Chairs
Antonio Citterio, 2022

Saarinen High Table
Eero Saarinen, 1957



Modern Always®

Antonio Citterio — *Klismos Collection* by Knoll



144 - 145



Antonio Citterio — *Klismos Collection* by Knoll

Ideal for creating a relaxation and conversation space are the Klismos armchair and chaise longue, with their fine comfort from stuffing upholstered in either leather or fabric. The chaise longue's roller headrest is fastened to the oakwood structure with leather laces in either natural colour or black, in harmony with the wood finish.

Grâce au grand confort de leurs rembourrages recouverts de cuir ou de tissu, le fauteuil et la chaise longue Klismos sont parfaits pour créer un espace propice à la détente et à la conversation. Le repose-tête en forme de rouleau de la chaise longue est attaché à la structure en chêne à l'aide de lacets en cuir naturel ou noir, en harmonie avec la finition du bois.

Klismos Chaise Longue
Antonio Citterio, 2022

Klismos Lounge Chair
Antonio Citterio, 2022

Saarinen Low Tables
Eero Saarinen, 1957

Ideali per creare una zona relax e conversazione sono la poltroncina e la chaise longue Klismos, con il grande comfort delle imbottiture rivestite in pelle o tessuto. Il poggiatesta a rullo della chaise longue è vincolato alla struttura in legno di rovere con lacci in pelle naturale o nera, in armonia con la finitura del legno.

Der Klismos Sessel und die Chaiselongue eignen sich ideal, um einen Raum zum Entspannen und für Gespräche zu schaffen. Sie bieten einen hohen Komfort durch die Polsterung in Leder oder Stoff. Die Rollenköpfsstütze der Chaiselongue ist mit naturfarbenen oder schwarzen Lederschnüren am Eichenholzrahmen befestigt, die mit der Holzoberfläche harmonieren.



Knoll. The Original Design

In the Klismos sofa Citterio develops the design of the chair and armchair in a shape that is at once symmetrical, dynamic and cosy, recalling the classic récamier. Like the chaise longue, the sofa has an oakwood structure in either natural colour or black; the removable cushions are upholstered in fabric or leather.

Pour le canapé Klismos, Citterio approfondit le design de la chaise et du fauteuil avec une forme symétrique, à la fois dynamique et accueillante, évocation du récamier classique. À l'instar de la chaise longue, le canapé arbore une structure en chêne naturel ou noir et les coussins déhoussables sont recouverts en tissu ou en cuir.

Nel divano Klismos Citterio sviluppa il disegno di sedia e poltroncina in una forma simmetrica, dinamica e insieme accogliente, che ricorda quella del classico récamier. Come la chaise longue, il divano ha struttura in legno di rovere color naturale o nero, i cuscini sfoderabili sono rivestiti in tessuto o in pelle.

Mit dem Sofa Klismos entwickelt Citterio das Design von Stuhl und Sessel in einer symmetrischen, dynamischen und zugleich gemütlichen Form, die an die klassische Récamière erinnert. Wie die Chaiselongue verfügt das Sofa über einen naturfarbenen oder schwarzen Eichenholzrahmen; die abnehmbaren Kissen sind mit Stoff oder Leder gepolstert.

Klismos Sofa
Antonio Citterio, 2022

Klismos Lounge Chair
Antonio Citterio, 2022

Klismos Bench
Antonio Citterio, 2022

Saarinen Lounge Height Table
Eero Saarinen, 1957

Antonio Citterio — *Klismos Collection* by Knoll





Antonio Citterio — *Citterio Table Collection*

In the Citterio collection's modern eclecticism, the organic materiality of the seats and the geometric linearity of the tables fit in well with the great inventions produced by Knoll, like those of Warren Platner or Eero Saarinen.

Au sein de l'éclectisme moderne de la collection signée Citterio, la matérialité organique des sièges ainsi que la linéarité géométrique des tables s'intègrent dans les grandes inventions de la production Knoll, comme celles de Warren Platner ou d'Eero Saarinen.

Nell'eclettismo moderno della collezione Citterio, la matericità organica delle sedute e la linearità geometrica dei tavoli si integra alle grandi invenzioni della produzione Knoll, come quelle di Warren Platner o Eero Saarinen.

Im modernen Eklektizismus der Citterio-Kollektion ergänzen sich die organische Materialität der Stühle und die geometrische Linearität der Tische mit den großen Erfindungen der Knoll-Produktion, wie denen von Warren Platner und Eero Saarinen.



Antonio Citterio — *Citterio Table Collection*

Citterio High Table
Antonio Citterio, 2022

Klismos Bench
Antonio Citterio, 2022

Tulip Chairs and Armchair
Eero Saarinen, 1957

Citterio Console
Antonio Citterio, 2022

Bertoia Bird Armchair
Harry Bertoia, 1952



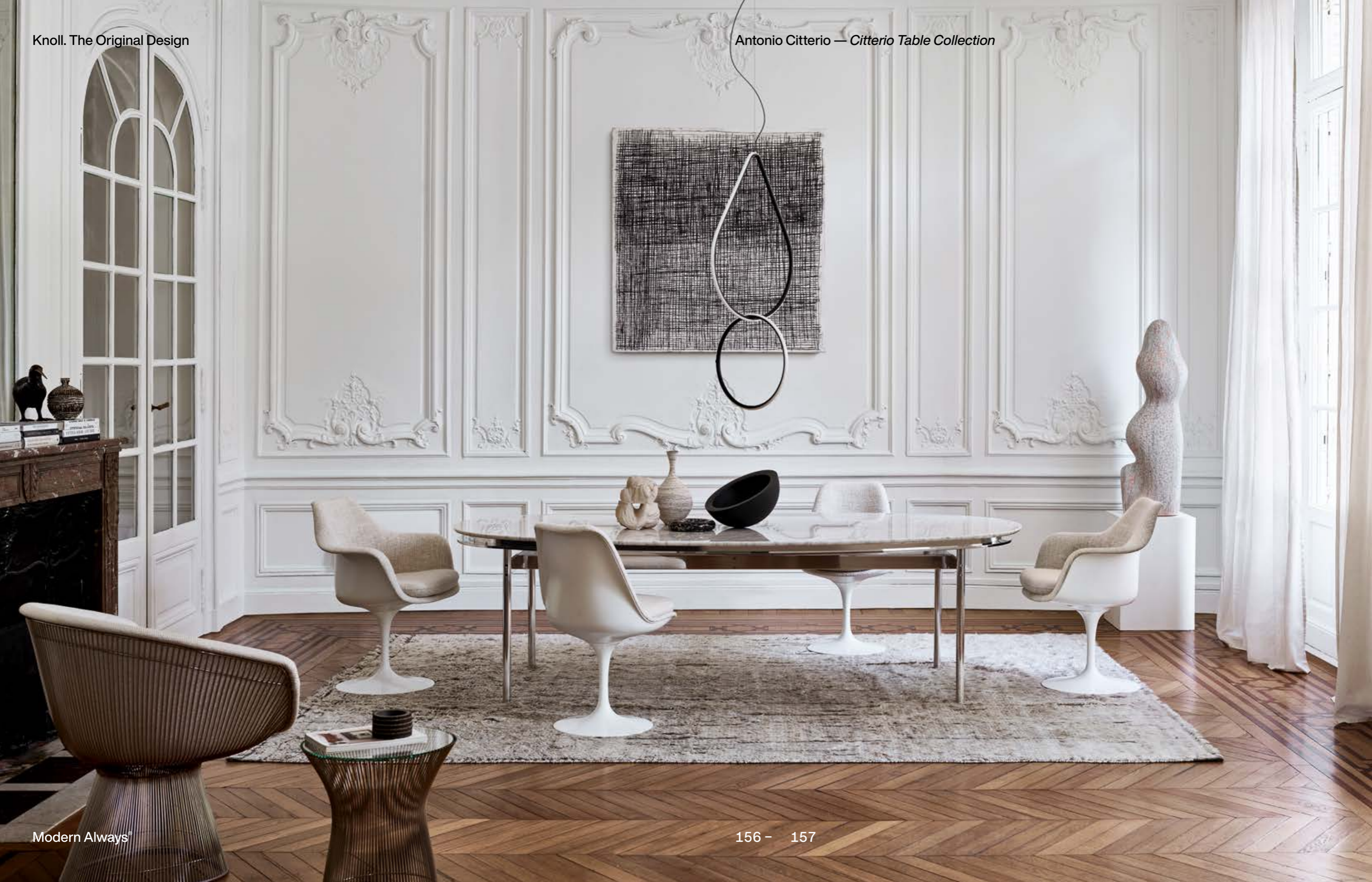

Knoll. The Original Design



Modern Always®

Antonio Citterio — *Citterio Table Collection*

Citterio High Table
Antonio Citterio, 2022

Bertoia Bird Armchair
Harry Bertoia, 1952

Citterio Side Table
Antonio Citterio, 2022







The organic and technological architecture of Frank Owen Gehry has had a great impact on the history of contemporary design. Gehry is one of the “starchitects” of our time. He has combined an intensely manual and materic sensibility with the use of the most advanced technologies. In this way, he has also been able to revitalize ancient materials like wood, generating visionary sculptural results of forceful artistic personality.

L'architecture organique et technologique de Frank Owen Gehry a profondément marqué l'histoire du design contemporain. Il est l'un des « architectes stars » de notre époque, surtout grâce à ses projets muséaux. Dès ses débuts, il a associé une sensibilité formelle profondément manuelle et matérielle avec les technologies les plus avancées. Cette démarche lui permet d'innover même avec des matériaux anciens comme le bois pour atteindre des résultats plastiques absolument visionnaires et dotés d'une forte personnalité artistique.

L'architettura organicista e tecnologica di Frank Owen Gehry ha segnato profondamente la storia del progetto contemporaneo. Destinato, grazie soprattutto ai suoi progetti museali, a divenire una delle “archistar” del nostro tempo, sin dagli esordi egli integra una sensibilità formale profondamente manuale e materica con l'alleanza delle tecnologie più avanzate. In questo modo egli è riuscito a innovare anche materiali antichi, come il legno, portandoli verso esiti plastici di grande visionarietà e forte personalità artistica.

Die organistische und technologische Architektur von Frank Owen Gehry hatte großen Einfluss in der Geschichte des zeitgenössischen Designs. Vor allem dank seiner stark beachteten Projekte für Museen wurde Gehry von Anfang an zu einem „Stararchitekten“ unserer Zeit, der schon immer eine handwerkliche und gegenständliche Sensibilität mit dem Einsatz fortschrittlichster Technologie verband. So konnte er althergebrachte Materialien wie Holz wiederbeleben und schuf skulpturale Visionen mit einer starken, künstlerischen Persönlichkeit.

Knoll. The Original Design

Inspired by the apple crates he had played on as a child, Pritzker Prize-winning architect Frank Gehry created the ribbon-like design of the Cross Check Chair with interwoven maple strips.

Ispirandosi alle ceste di mele, con cui giocava quando era bambino, l'architetto Frank Gehry, vincitore del Pritzker Prize, crea l'innovativa poltrona Cross Check intrecciando strisce d'acero curvate.

Inspiré par les paniers de pommes sur lesquels il jouait, enfant, l'architecte Frank Gehry, lauréat du Prix Pritzker créa le fauteuil Cross Check fait de rubans d'érable entrelacés.

Inspiziert von Apfelkisten, mit denen er als Kind gespielt hat, entwarf der Pritzker-Preis-Gewinner Architekt Frank Gehry das Design aus Bändern des Cross Check Stuhles mit verflochtenen Ahorn Bändern.

Cross Check Armchair
Frank Gehry, 1990

Power Play Armchair
Frank Gehry, 1990



Frank Gehry — Gehry Collection





Tobia Scarpa — *Bastiano Sofa Collection*

When Tobia Scarpa first designed the Bastiano Sofa in 1962, he wanted to provide seating that was sophisticated and elegant, yet casual and comfortable. In keeping with the spirit that inspired it, the Bastiano Collection has been adapted to the proportions of a more contemporary domestic environment. The collection now offers wider and more relaxed designs to build on the extremely comfortable and elegantly informal concept that generated it.

Lorsque Tobia Scarpa a conçu le canapé Bastiano pour la première fois en 1962, il voulait proposer une assise à la fois sophistiquée et élégante, mais décontractée et confortable. Fidèle à l'esprit qui l'a inspirée, la collection Bastiano a été adaptée aux proportions d'un environnement résidentiel plus contemporain. La collection propose désormais des designs plus larges et plus décontractés pour réaffirmer le concept extrêmement confortable et élégamment informel qui l'avait généré.

Quando Tobia Scarpa progettò per la prima volta il divano Bastiano nel 1962, voleva fornire una seduta sofisticata ed elegante, ma casual e confortevole. In linea con lo spirito che l'ha ispirata, la Collezione Bastiano è stata adattata alle proporzioni di un ambiente domestico più contemporaneo. La collezione offre ora design più ampi e rilassati per costruire il concetto estremamente confortevole ed elegantemente informale che l'ha generata.

Als Tobia Scarpa 1962 das Bastiano-Sofa zum ersten Mal entwarf, wollte er Sitzgelegenheiten bieten, die raffiniert und elegant, aber dennoch lässig und komfortabel sind. Entsprechend dem Geist, der sie inspiriert hat, wurde die Bastiano-Sammlung an die Proportionen eines zeitgemäßerer häuslichen Umfelds angepasst. Die Kollektion bietet jetzt breitere und entspanntere Designs, um auf dem äußerst komfortablen und elegant informellen Konzept aufzubauen, das sie hervorgebracht hat.



Tobia Scarpa — *Bastiano Sofa Collection*

The pleasure and the softness of the cushions naturally marry the sturdy strips of the wood frame.

La morbidezza delle imbottiture si accosta con naturalezza alle solide fasce della struttura esterna in legno.

L'agrément du cuir et la souplesse des coussins se marient tout naturellement au cadre en bois.

Die weiche angenehme Kissenoberfläche steht mit dem soliden Holzrahmen perfekt im Einklang.

Bastiano Armchair
Tobia Scarpa, 1962

Saarinen Low Table
Eero Saarinen, 1957





Edward Barber & Jay Osgerby — *Pilot Collection for Knoll*

The Pilot Chair embodies refinement, comfort and exceptional craftsmanship. A modern piece with a unique silhouette.

Le fauteuil « Pilot Chair » incarne l'élégance, le confort et un savoir-faire exceptionnel, un objet moderne à la silhouette unique.

La poltrona Pilot racchiude in sé raffinatezza, comfort, ricercatezza dei materiali e altissima artigianalità. Un arredo moderno con una silhouette unica.

Der Pilot Chair verkörpert Raffinesse, Komfort und außergewöhnliche Handwerkskunst. Ein modernes Möbelstück mit einer einzigartigen Silhouette.



Pilot Chair for Knoll
Edward Barber & Jay Osgerby, 2015





Pilot Chair for Knoll
Edward Barber & Jay Osgerby, 2015

Piton Stool
Edward Barber & Jay Osgerby, 2015



Casual comfort meets modern simplicity. An elegant architectural profile is reinforced by stitching details.

Une simplicité moderne pour un confort au quotidien. Une élégance architecturale soulignée par le détail raffiné des coutures.

Il comfort informale incontra la semplicità contemporanea. Un design elegante e architettonico caratterizzato da dettagli sartoriali.

Lässiger Komfort trifft auf moderne Einfachheit. Ein elegantes Architekturprofil, verstärkt durch genähte Details.



Sofa Collection
Edward Barber & Jay Osgerby,
2016

Saarinens Low Tables
Eero Saarinen, 1957

Laccio Tables
Marcel Breuer, 1925





Marc Krusin — *Krusin Collection 016*

This collection associates restrained and compact forms with a comfortable and generous seat.

La collection associe des formes compactes et toutes en retenue avec une assise confortable et généreuse.

La collezione associa forme contenute e compatte ad una seduta comoda e generosa.

Die Kollektion verbindet verhaltene, kompakte Formen mit einer bequemen und großzügigen Sitzfläche.





Drawing inspiration from traditional designs, but updated with an industrialized craft aesthetic, the Krusin End Table complements the Krusin Lounge and Side Chairs.

Inspirée par un dessin traditionnel mais réactualisé à travers une esthétique artisanale industrielle, la table d'appoint Krusin vient compléter le fauteuil et les chaises de la collection.

Ispirati al design tradizionale, ma con un tocco moderno conferito da un'estetica artigianale industrializzata, i tavolini completano la collezione di sedute Krusin.

Von traditionellem Design inspiriert und in der Ästhetik des industriellen Handwerks neu interpretiert: Der Krusin End Table ergänzt die Krusin Lounge und Side Chairs.

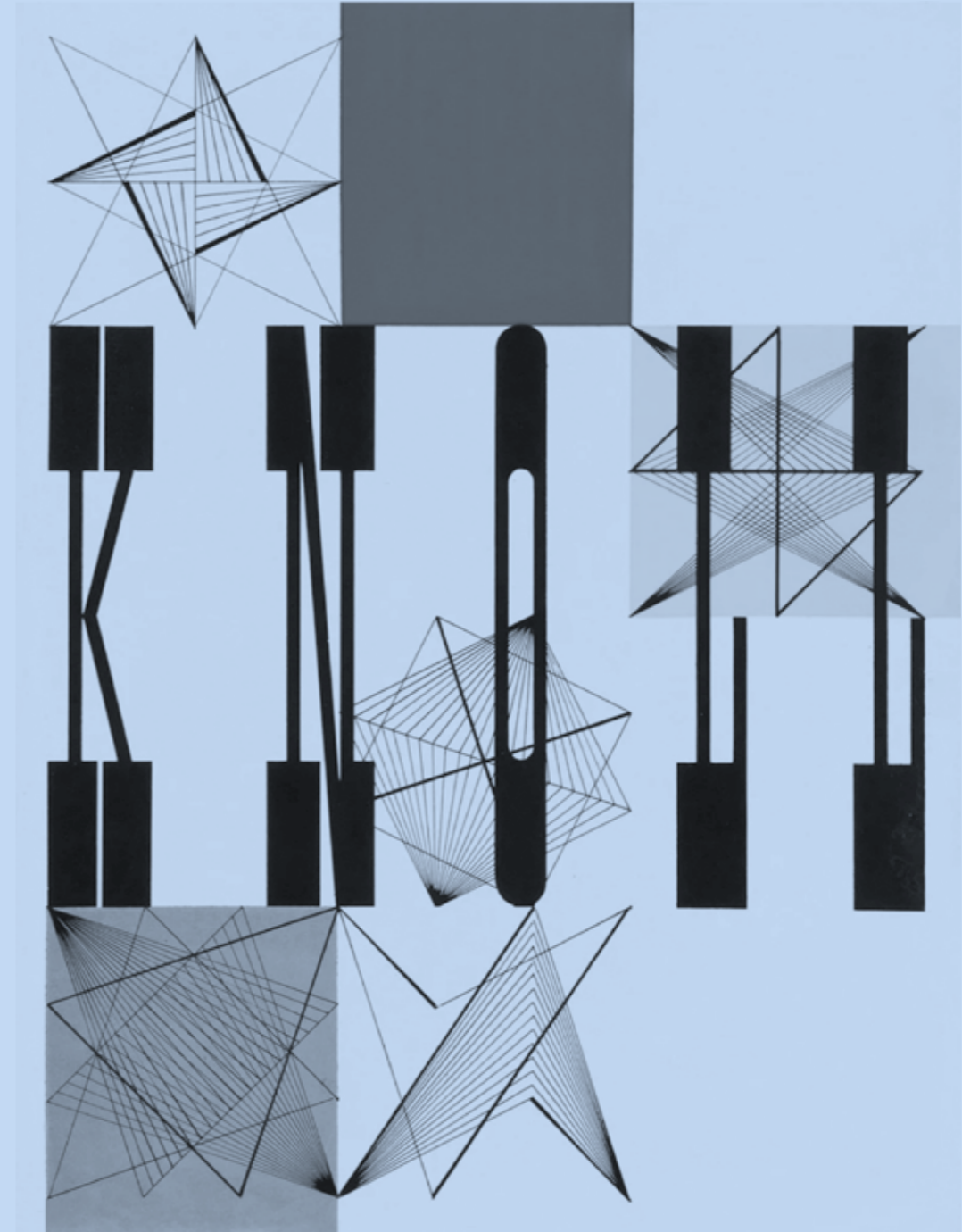

April 25, 1961

E. SAARINEN

2,981,578

TABLE WITH HOLLOW CENTRAL FEDESTAL SUPPORT

Original Filed May 2, 1957

2 Sheets-Sheet 2

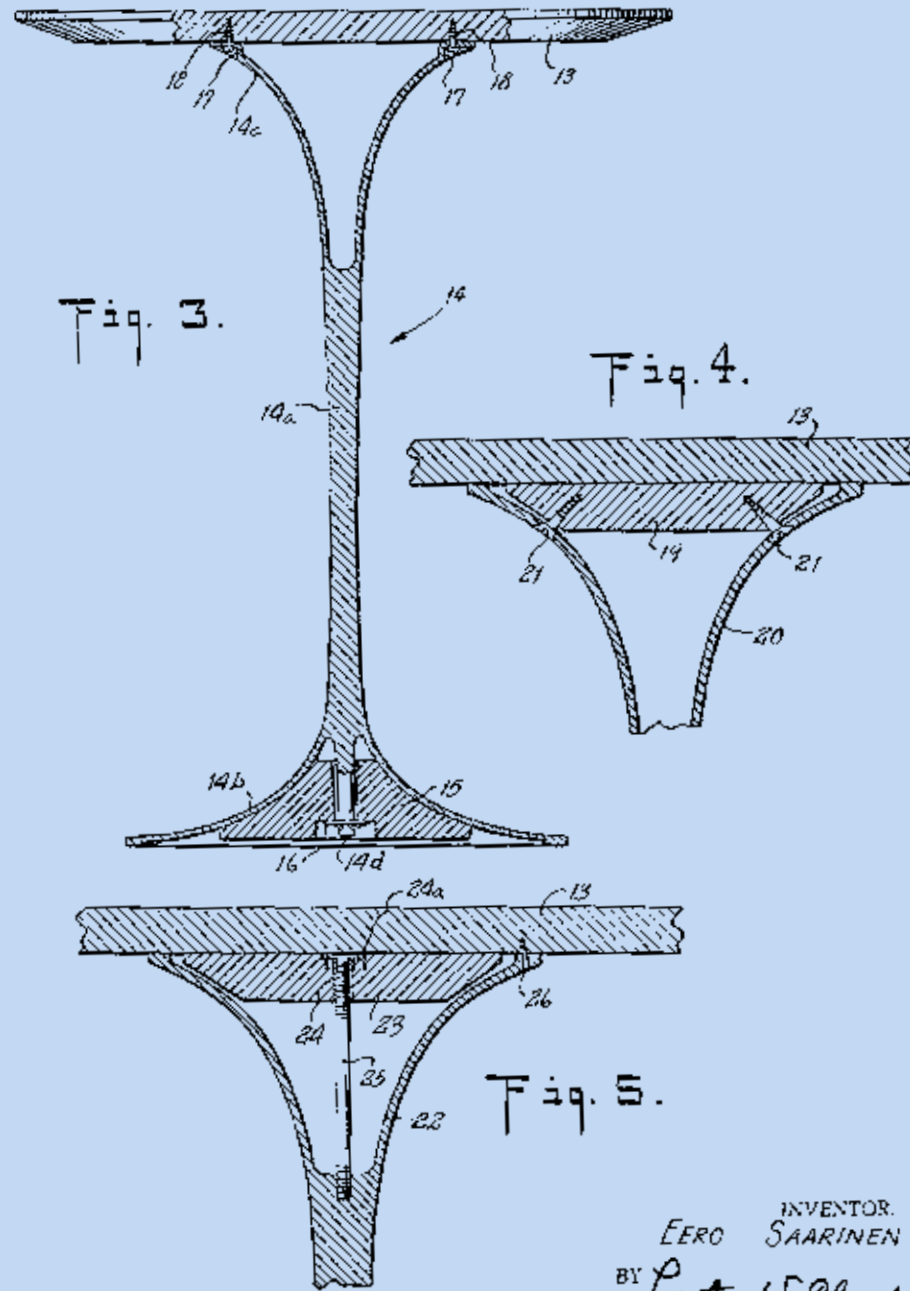

INVENTOR.
EERO SAARINEN
BY *Lester W. Clark*
ATTORNEY

Ideas are the greatest heritage for a designer just like reliability is for a company. This is why Knoll has always protected author design ensuring the adherence to the original projects of great masters that, over time, have shaped the history of the company as well as that of the global design. Present in the most important Museum collections in the world, Knoll icons are synonyms of authenticity.

Il patrimonio più grande per un progettista sono le sue idee e per un'azienda è la sua affidabilità. Per questo Knoll da sempre tutela il design d'autore garantendo la fedeltà al progetto originale dei grandi maestri che hanno formato nel tempo la storia dell'azienda e, contemporaneamente, quella del design mondiale. Presenti nelle più importanti collezioni museali del mondo, le icone di Knoll sono sinonimo di autenticità.











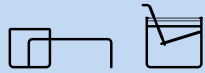

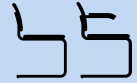
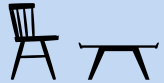







Les idées sont l'héritage le plus précieux du designer, tout comme la fiabilité pour une entreprise. C'est pourquoi Knoll a toujours préservé le design de ses créateurs et veillé au respect des projets originaux de ces maîtres éminents qui, au fil du temps, ont façonné l'histoire de l'entreprise ainsi que celle du design international. Exposées dans les plus grands musées du monde, les pièces Knoll iconiques sont un gage d'authenticité.







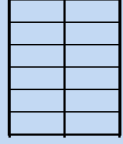
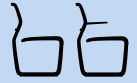
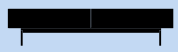
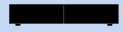



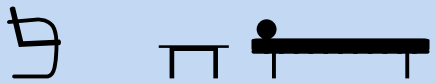

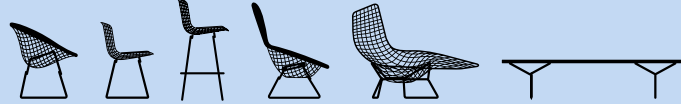



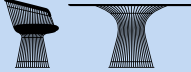





Ideen sind das größte Vermächtnis für einen Designer, genauso wie Zuverlässigkeit für ein Unternehmen. Deshalb sorgt Knoll seit Anbeginn für den Schutz des Autoredesigns und stellt das Festhalten an die ursprünglichen Projekte jener großen Meister sicher, die im Laufe der Zeit sowohl die Geschichte des Unternehmens als auch die des globalen Designs geprägt haben. Die Ikonen von Knoll, vertreten in den wichtigsten Museumssammlungen der Welt, sind ein Synonym für Authentizität.



Florence Knoll presenting her designs

Knoll. The Original Design

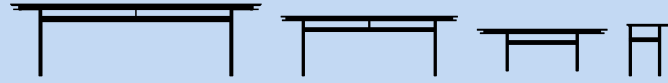
 1925 Laccio Tables Wassily Chair Marcel Breuer	 1927 MR Side Chair MR Table Krefeld™ Lounge Mies van der Rohe	 1927-31 MR Armless Chair, MR Armchair MR Chaise Longue, MR Stool MR Adjustable Chaise Longue Mies van der Rohe	 1928 Cesca Collection Marcel Breuer
 1946 Straight Chair Splay Table George Nakashima	 1946 Womb Chair Eero Saarinen	 1948 Coffee Table Alexander Girard	 1949 Mini Desk Franco Albini
 1958 Four Seasons Barstool Mies van der Rohe	 1960 Pollock Armchair Charles Pollock	 1961 Florence Knoll Table Desk Florence Knoll Credenza Florence Knoll	 1962 Bastiano Sofa Tobia Scapa
 1970 Lunario Table Cini Boeri	 1971 Pfister Lounge Collection Charles Pfister	 1982 Stump Table Lucia Mercer	 1983 Handkerchief Chair Vignelli Designs
 2009 Spark® Chair Don Chadwick	 2009 Lounge Collection Jehs + Laub	 2011 Krusin Chairs and Tables Marc Krusin	 2012 Sofa Collection Architecture & Associés
 2018 KN01, KN02, KN03, KN04, KN05 Piero Lissoni	 2018 Red Baron Piero Lissoni	 2018 Aluminium Chair Marc Newson	
 2022 Matic Credenzas Piero Lissoni	 2022 Matic Storage Units Piero Lissoni	 2022 Klismos Collection by Knoll Antonio Citterio	

 1929 Barcelona® Chair and Stool Mies van der Rohe	 1930 Brno Chair Barcelona® Table, Barcelona® Day Bed Mies van der Rohe	 1938 Butterfly Chair Antonio Bonet, Juan Kurchan & Jorge Ferrari-Hardoy	 1943 Risom Chairs Jens Risom
 1952 Diamond Chair, Side Chair, Stool, High Back Chair, Asymmetric Chaise, Bertoia Bench Harry Bertoia	 1954 Florence Knoll Lounge Collection, Tables Florence Knoll	 1957 Pedestal Table Tulip Chairs Eero Saarinen	
 1963 Executive Chair Charles Pollock	 1965 Jumbo Table Gae Aulenti	 1966 Platner Chair Platner Table Warren Platner	 1966 1966 Collection® Petal® Table Richard Schultz
 1986 Eastside Lounge Sottsass Associates	 1990 Gehry Chair Collection Face Off Table Frank Gehry	 1993 PaperClip Table Vignelli Designs	 2007 Lovegrove Table Ross Lovegrove
 2015 Pilot Collection, Stool Piton Stool, Table Edward Barber & Jay Osgerby	 2016 Krusin Collection 016 Marc Krusin	 2016 Avio Sofa System Matrioska Credenza Piero Lissoni	 2017 Grasshopper Table Piero Lissoni
 2019 Gould Sofa Collection Piero Lissoni	 2019 Smalto Table Edward Barber & Jay Osgerby	 2020 Matic Collection KN06, KN07 Piero Lissoni	 2022 Panoramic Sofa Panoramic Low Table Piero Lissoni
 2023 Citterio Table Collection Antonio Citterio	 2023 Outdoor Collection Piero Lissoni		

Manufacturing thanks to the skilful hands of man and producing through the machine artificial intelligence are not contrasting actions. On the contrary, the whole Knoll history is characterised by the integration between artisanship and technology, separated, though never opposing. The difference is made by the experience in understanding when to use a production instrument or another, in an integrated process.

Realizzare con le mani sapienti dell'uomo e produrre tramite l'intelligenza artificiale delle macchine non sono modi del fare in opposizione. Anzi, tutta la storia di Knoll è quella dell'integrazione tra artigianalità e tecnologia, distinte, ma mai opposte. A fare la differenza è l'esperienza nel riconoscere quando utilizzare un mezzo produttivo o l'altro, in un processo integrato.

Fabriquer grâce au savoir-faire de mains expertes et produire grâce à l'intelligence artificielle des machines ne sont pas des processus incompatibles. Tout au long de son histoire, Knoll a favorisé l'association de l'artisanat et de la technologie, sans jamais les opposer. Leur point de divergence vient du fait qu'il faut déterminer dans un processus intégré quand utiliser tel outil de production ou tel autre.

Dank der geschickten Hände der Menschen und der Produktion durch die maschinelle künstliche Intelligenz gibt es keine gegensätzlichen Handlungen in der Fertigung. Ganz im Gegenteil: Die gesamte Geschichte von Knoll ist geprägt von der Integration zwischen Handwerk und Technologie, die zwar geteilt, aber niemals gegensätzlich sind. Den Unterschied macht die Erfahrung im Verständnis dafür, wann das eine oder andere Produktionsmittel in einem integrierten Prozess eingesetzt werden sollte.

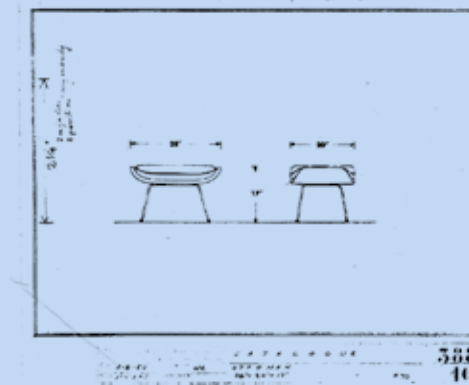



Bertoia Chair production detail



Bertoia Chair and Platner Table production line

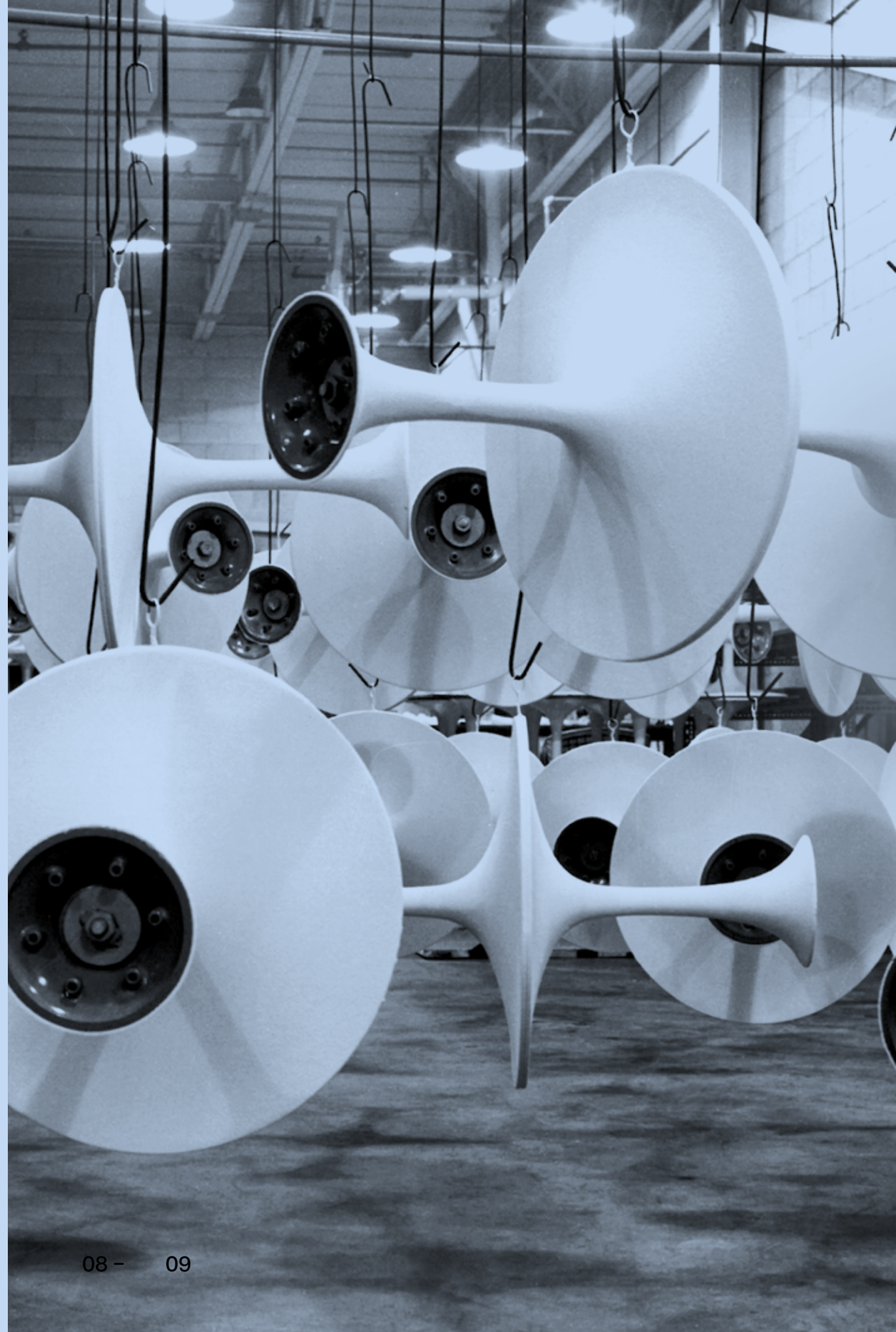



Knoll Factory in Foligno – Italy



Production line



Knoll Planning Department

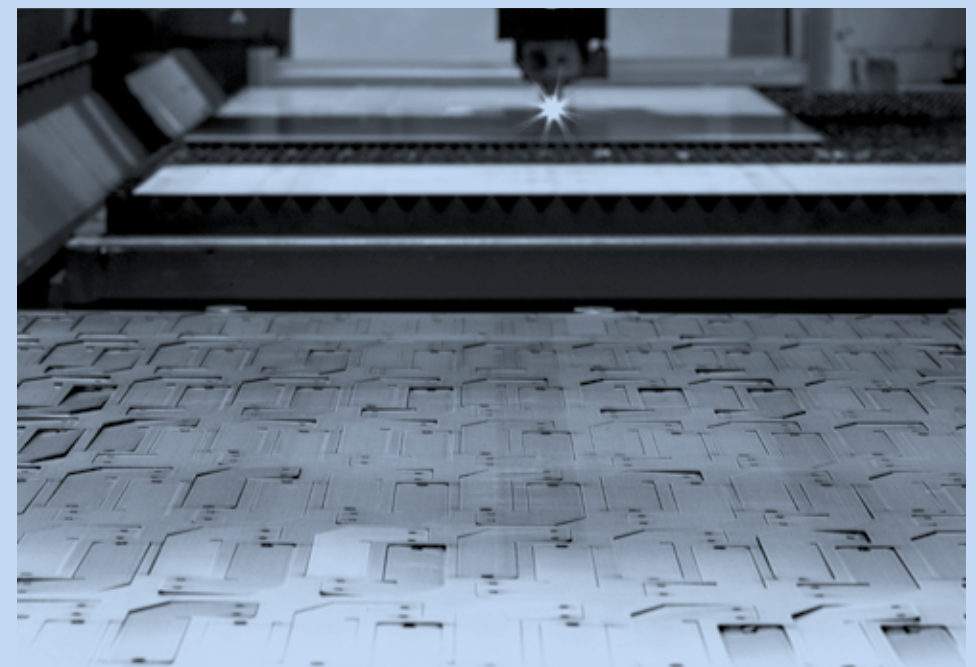

Metal production detail



Barcelona cushion production detail



Platner Easy Chair production detail



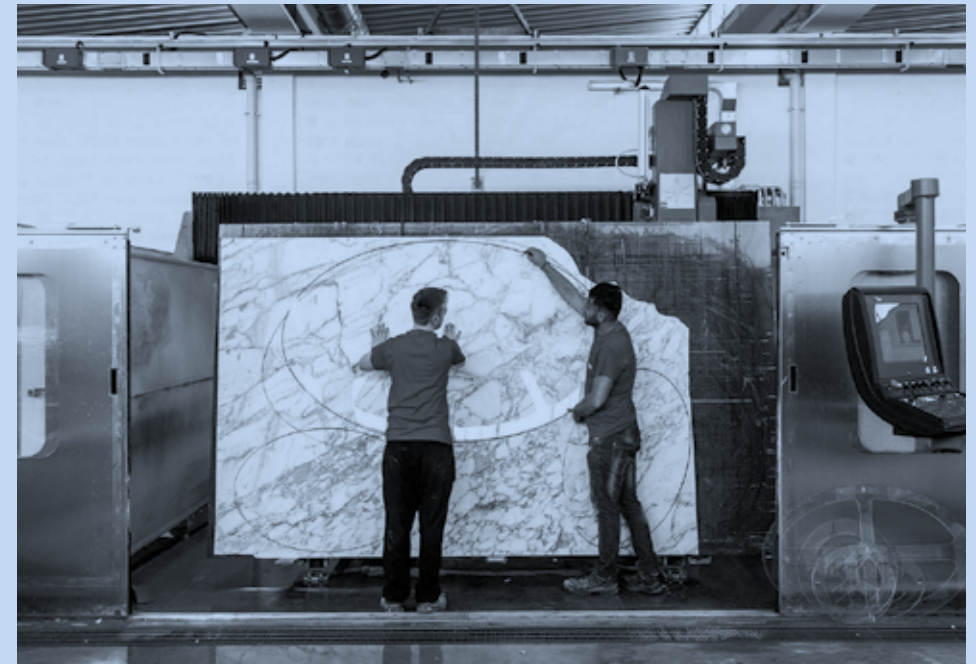

Skilled craftsmen hand-finish the table edges



Marble hand finishing process



The true innovation is the capacity to continuously renovate. We certainly innovate using cutting edge machines and technologies, but also always building a new dialogue with designers and listening to the needs of the public that change over time. A foundation that was given by Hans and Florence Knoll since the beginning and that now continues in the increasingly wide and versatile offers for a rapidly changing world.

La vera innovazione è la capacità di rinnovarsi sempre. Certamente si innova utilizzando macchinari e tecnologie all'avanguardia, ma anche costruendo sempre un nuovo dialogo con i progettisti e ascoltando le esigenze del pubblico che mutano nel tempo. Un'impostazione, questa, data da Hans e Florence Knoll sin dagli albori e che oggi prosegue nelle offerte sempre più ampie e versatili per un mondo in rapido cambiamento.

La véritable innovation, c'est être capable de se renouveler sans cesse. Nous favorisons l'innovation en utilisant des technologies et des machines de pointe, mais aussi en nouant un dialogue toujours nouveau avec les designers et en écoutant les besoins du public en perpétuelle évolution. Un principe fondamental prôné par Hans et Florence Knoll dès le départ, qui se perpétue aujourd'hui à travers nos offres toujours plus larges pour s'adapter à l'évolution rapide de notre monde.

Die wahre Innovation liegt in der Fähigkeit zur ständigen Erneuerung. Ganz sicher sind wir innovativ beim Einsatz modernster Maschinen und Technologien, aber wir sind es auch, wenn es um den Aufbau eines neuen Dialogs mit Designern und um die Beachtung der sich im Laufe der Zeit ändernden Bedürfnisse der Kunden geht. Eine Grundlage, die von Hans und Florence Knoll von Anfang an gegeben war und die sich nun in den immer breiter und vielseitiger werdenden Angeboten für eine sich schnell verändernde Welt fortsetzt.



Florence Knoll presenting her project

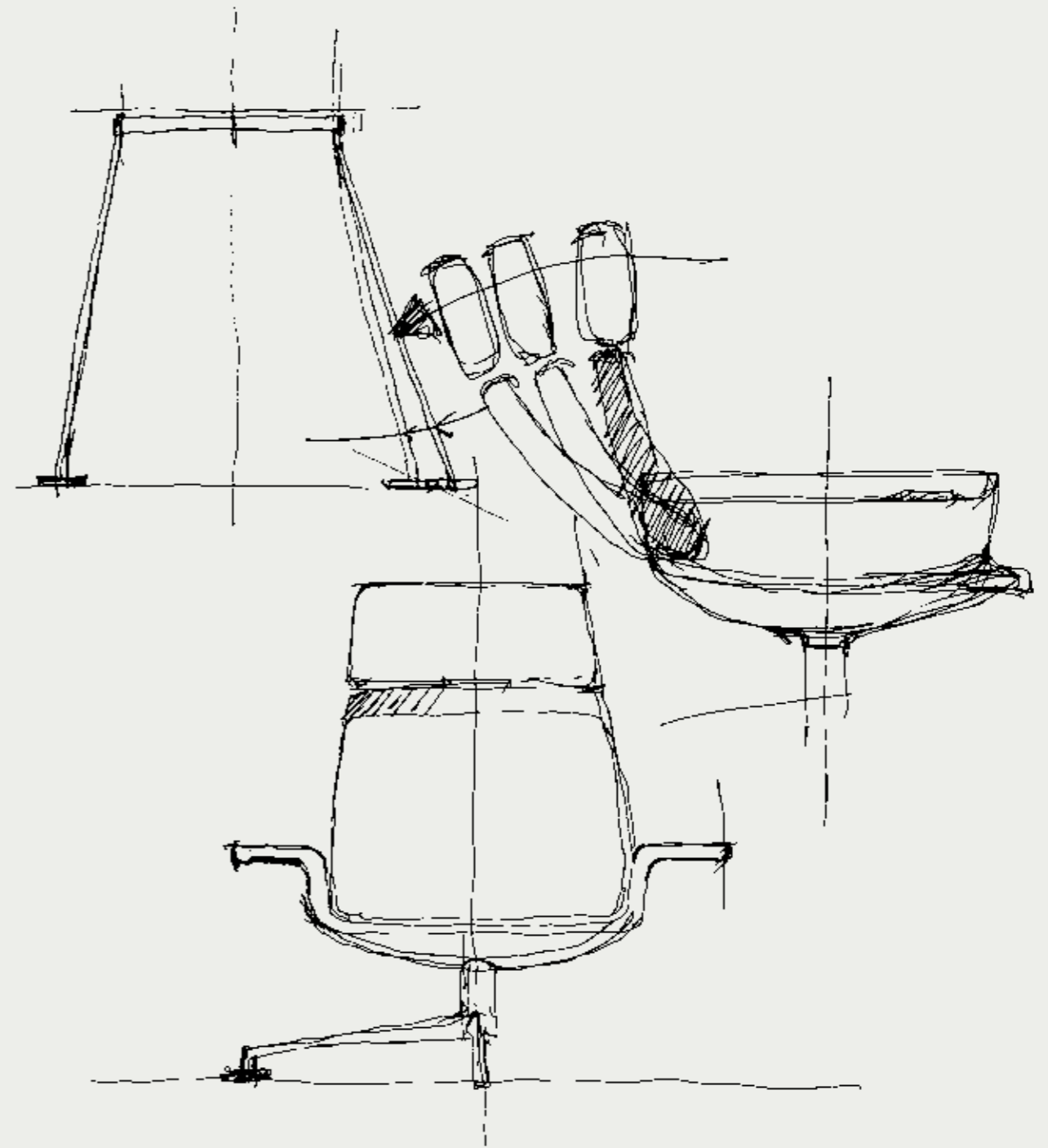
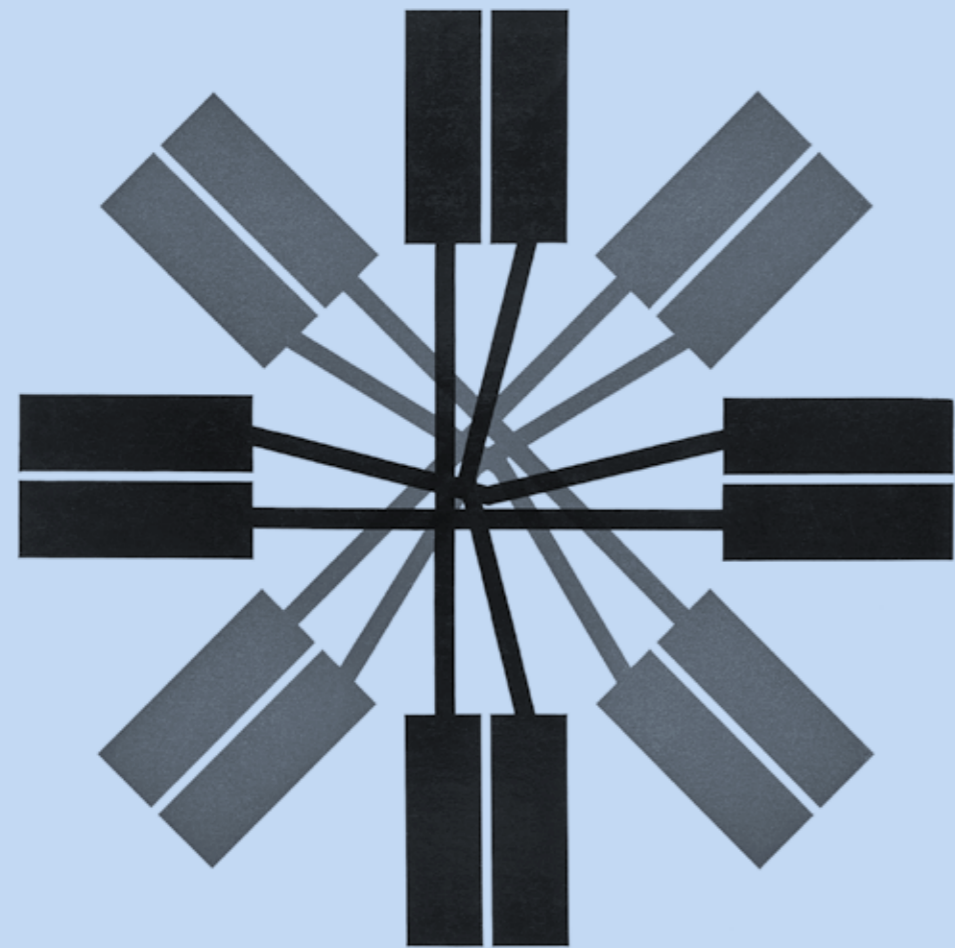

KN Collection by Knoll



KN01
L 105 x D 80 x H 75 cm
p. — 062, 064-065



KN02
L 95 x D 80 x H 100 cm
p. — 069



KN03
L 72 x D 60 x H 42 cm
p. — 069



KN04
L 88 x D 75 x H 67 cm
p. — 052, 057, 058-059, 060



KN04
L 88 x D 75 x H 67 cm



KN04
L 88 x D 75 x H 67 cm

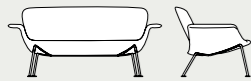

KN05
L 150 x D 78 x H 70 cm
p. — 057, 061

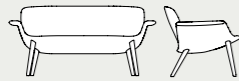

KN05
L 150 x D 78 x H 70 cm

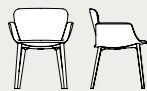

KN06
L 63 x D 56 x H 79 cm
p. — 040, 043, 044-045, 046, 048-049



KN06
L 63 x D 56 x H 79 cm
p. — 051



KN06
L 62.5 x D 69.5 x H 76/83 cm



KN06
L 62.5 x D 71 x H 72.5/79.5 cm
p. — 055



KN07
L 48 x D 52 x H 74 cm
p. — 048-049



KN07
L 51 x D 54.5 x H 75 cm
p. — 051



KN07
L 51.5 x D 67.5 x H 72.5/79.5 cm



KN07
L 51.5 x D 71 x H 69/76 cm
p. — 066, 067

Gehry Collection



Cross Check Armchair
L 72 x D 63 x H 85 cm
p. — 023, 164

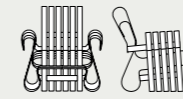

Power Play Armchair
L 79 x D 77 x H 83 cm
p. — 165



Off Side Ottoman
L 59 x D 59 x H 21 cm



Hat Trick Armchair
L 59 x D 57 x H 85 cm



Hat Trick Chair
L 51 x D 57 x H 85 cm

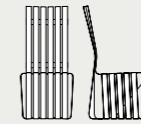

High Sticking Chair
L 51 x D 60 x H 110 cm

Pilot Collection for Knoll



Pilot Chair – low back
L 60/69 x D 70 x H 81 cm
p. — 172, 175



Pilot Chair – high back
L 60/69 x D 77 x H 100 cm
p. — 176-177, 179



Pilot Ottoman
L 42 x D 51 x H 49 cm
p. — 172



Piton Stool
Ø 45.7 x H 33.5 cm
p. — 172

Krusin Collection 016



Chair
L 53 x D 53 x H 76 cm
p. — 186, 188-189



Chair with Arms
L 63 x D 53 x H 76 cm



Armchair
L 63 x D 53 x H 71 cm
p. — 188-189

Antonio Citterio Seating Collection



Chair and Seat Pad
L 59 x D 60 x H 73 cm
L 45.5 x D 42 x H 2.5 cm
p. — 142-143, 145



Chair and Seat Pad
L 59 x D 60 x H 73 cm
L 45.5 x D 42 x H 2.5 cm
p. — 144



Lounge Chair and Seat Pad
L 68 x D 60 x H 71 cm
L 55.5 x D 51 x H 2.5 cm
p. — 140, 146, 151



Stool and Seat Pad
L 71.5 x D 48 x H 43 cm
L 62 x D 39 x H 2.5 cm
p. — 151



Bench and Seat Pad
L 91.5 x D 48 x H 48.5 cm
L 82 x D 38 x H 2.5 cm



Bench and Seat Pad
L 133.5 x D 48 x H 48.5 cm
L 124 x D 38 x H 2.5 cm
p. — 142-143, 154

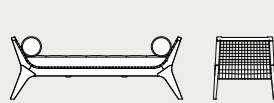

Sofa
L 172 x D 67.5 x H 62 cm
p. — 151



Chaise Longue
L 187.5 x D 78.5 x H 92 cm
p. — 146, 148-149

Scarpa Collection

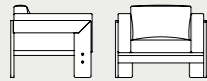

Bastiano lounge chair / Petite
L 86 x D 78 x H 70 cm
p. — 168

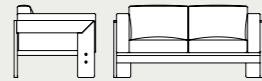

Bastiano two-seat sofa / Petite
L 141 x D 78 x H 70 cm

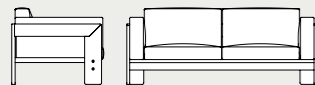

Bastiano three-seat / Grande
L 180 x D 88 x H 76 cm
p. — 170-171

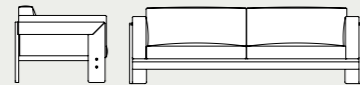

Bastiano three-seat / Grande
L 220 x D 88 x H 76 cm
p. — 166

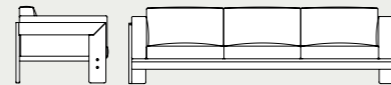

Bastiano three-seat / Grande
L 253 x D 88 x H 76 cm

Matic Sofa Collection

These products are part of a System Sofa Collection. More configurations are available.

Questi prodotti fanno parte di un sistema di divani. Sono disponibili altre configurazioni.

Ces produits font partie d'un système de canapés. Ils sont disponibles dans d'autres configurations.

Diese Produkte sind ein Teil des Systems der Sofakollektion. Mehr Konfigurationen sind erhältlich.

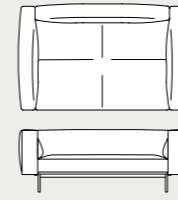

Quilted Sofa
L 169 x D 107 x H 62/64 cm

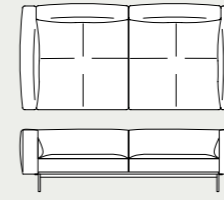

Quilted Sofa
L 224 x D 107 x H 62/64 cm

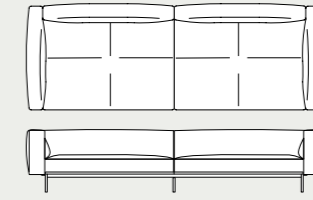

Quilted Sofa
L 294 x D 107 x H 62/64 cm

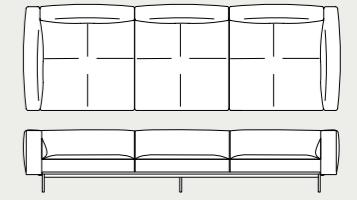

Quilted Sofa
L 314 x D 107 x H 62/64 cm

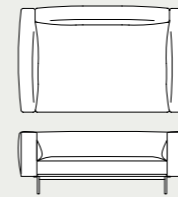

Sofa
L 169 x D 107 x H 62/64 cm

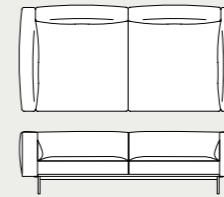

Sofa
L 224 x D 107 x H 62/64 cm

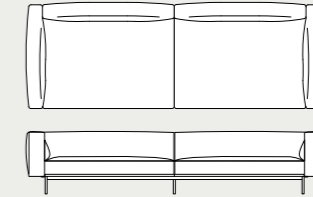

Sofa
L 294 x D 107 x H 62/64 cm

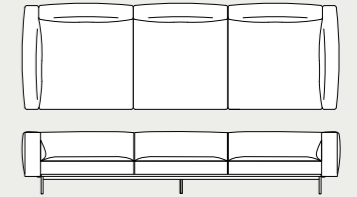

Sofa
L 314 x D 107 x H 62/64 cm

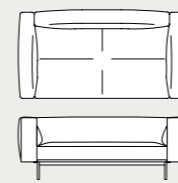

Compact Quilted Sofa
L 169 x D 90 x H 62/64 cm

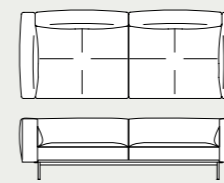

Compact Quilted Sofa
L 224 x D 90 x H 62/64 cm

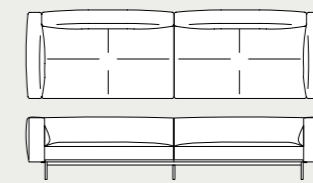

Compact Quilted Sofa
L 294 x D 90 x H 62/64 cm

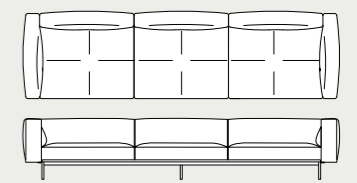

Compact Quilted Sofa
L 314 x D 90 x H 62/64 cm

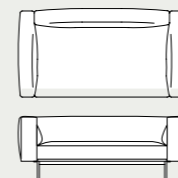

Compact Sofa
L 169 x D 90 x H 62/64 cm

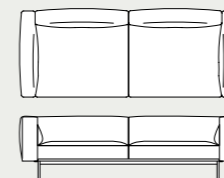

Compact Sofa
L 224 x D 90 x H 62/64 cm

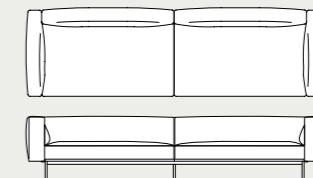

Compact Sofa
L 294 x D 90 x H 62/64 cm

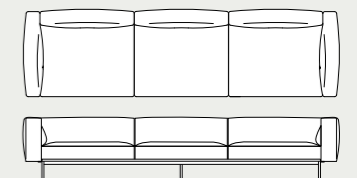

Compact Sofa
L 314 x D 90 x H 62/64 cm

Matic Sofa Collection

These products are part of a System Sofa Collection. More configurations are available.

Questi prodotti fanno parte di un sistema di divani. Sono disponibili altre configurazioni.

Ces produits font partie d'un système de canapés. Ils sont disponibles dans d'autres configurations.

Diese Produkte sind ein Teil des Systems der Sofakollektion. Mehr Konfigurationen sind erhältlich.

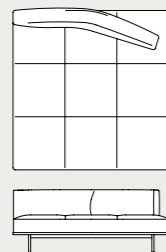
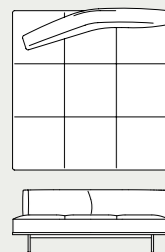

Chaise Longue Free-standing Righthand Quilted Version
L 150 x D 157 x H 62/64 cm

Chaise Longue Free-standing Lefhand Quilted Version
L 150 x D 157 x H 62/64 cm
p. — 018, 019, 020

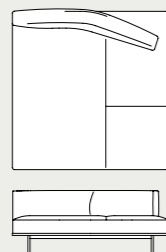
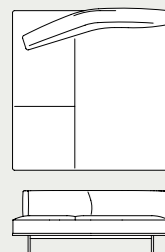

Chaise Longue Free-standing Righthand T-Seam Version
L 150 x D 157 x H 62/64 cm

Chaise Longue Free-standing Lefhand T-Seam Version
L 150 x D 157 x H 62/64 cm

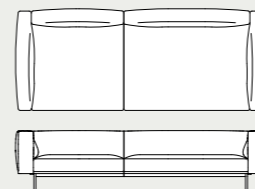

Righthand end module 112 + Lefthand end module 147
L 259 x D 107 x H 62/64 cm

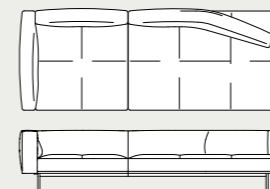

Righthand end module 112 + Lefthand end module with curved back
L 262 x D 107 x H 62/64 cm

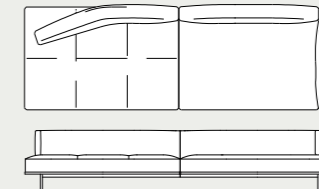

Righthand end module with curved back + Lefthand end module 147
L 297 x D 107 x H 62/64 cm
p. — 016-017

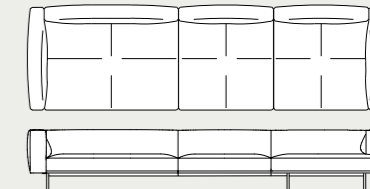

Righthand end module 147 + Lefthand end module 202
L 349 x D 107 x H 62/64 cm

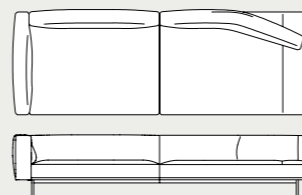

Righthand end module 147 + Lefthand end module with curved back
L 297 x D 107 x H 62/64 cm

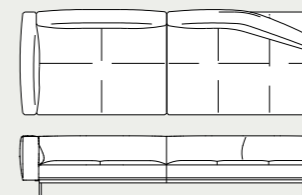

Righthand end module 147 + Lefthand end module with curved back
L 297 x D 107 x H 62/64 cm

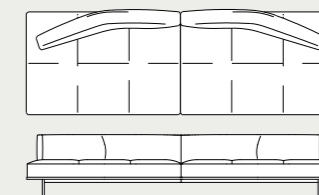

Righthand end module with curved back + Lefthand end module with curved back
L 300 x D 107 x H 62/64 cm
p. — 027

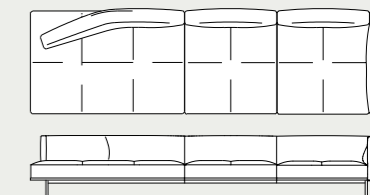

Righthand end module with curved back + Lefthand end module 202
L 352 x D 107 x H 62/64 cm

Matic Sofa Collection

These products are part of a System Sofa Collection. More configurations are available.

Questi prodotti fanno parte di un sistema di divani. Sono disponibili altre configurazioni.

Ces produits font partie d'un système de canapés. Ils sont disponibles dans d'autres configurations.

Diese Produkte sind ein Teil des Systems der Sofakollektion. Mehr Konfigurationen sind erhältlich.

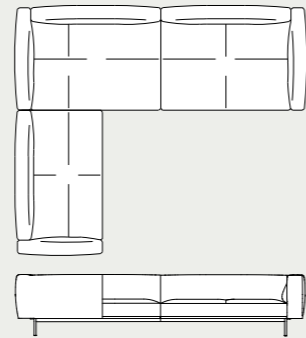
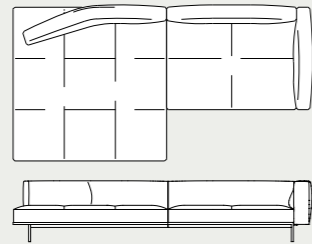
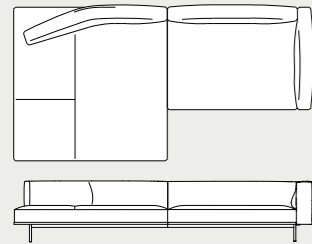

Righthand chaise longue end module + Lefthand end module 147
L 297 x D 157 x H 62/64 cm

Righthand chaise longue end module + Lefthand end module 147
L 297 x D 157 x H 62/64 cm

Righthand compact end module 147 + Corner module righthand + Lefthand end module 147
L 294 x D 254 x H 62/64 cm

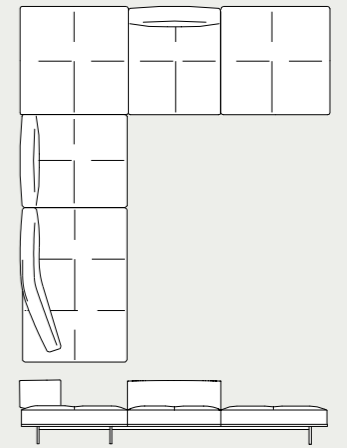
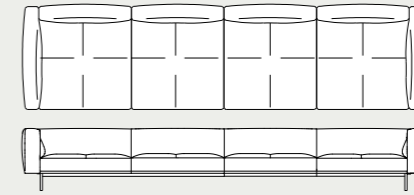
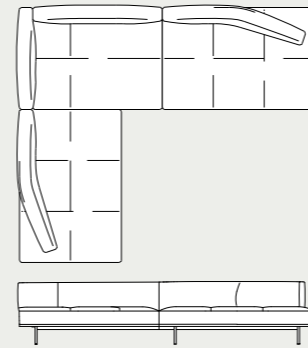

Righthand end module with curved back + Corner module righthand and lefthand end module with curved back
L 297 x D 257 x H 62/64 cm

Righthand module 202 + Lefthand end module 202
L 404 x D 107 x H 62/64 cm

Lefthand ottoman + Central module + Corner ottoman + Central module and end module with curved back
L 290 x D 340 x H 62/64 cm
p. — 036-039

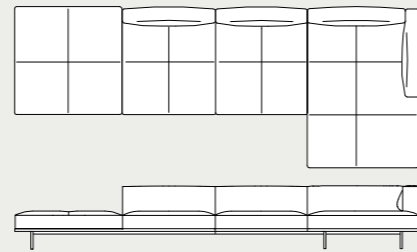
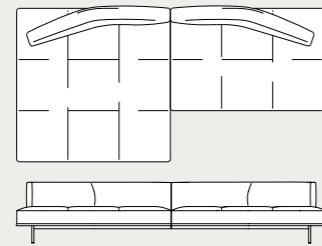
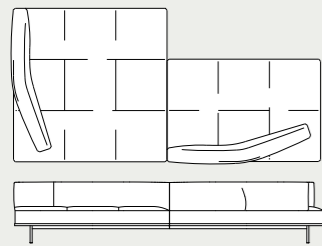

Righthand end module with curved back + Righthand chaise longue end module + Lefthand chaise longue end module
L 300 x D 157 x H 62/64 cm

Righthand chaise longue end module + Lefthand end module with curved back + Lefthand chaise longue end module
L 300 x D 157 x H 62/64 cm
p. — 010, 012-013, 015

Righthand ottoman + Central module 180 + Lefthand chaise longue end module
L 392 x D 157 x H 62/64 cm
p. — 022-023

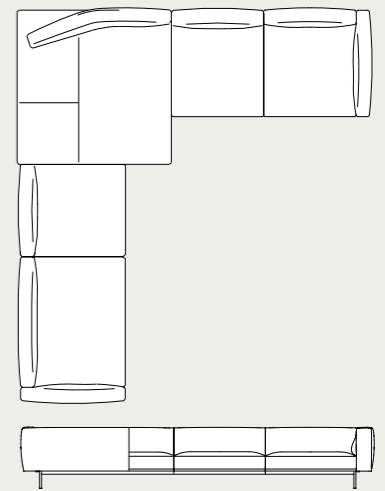
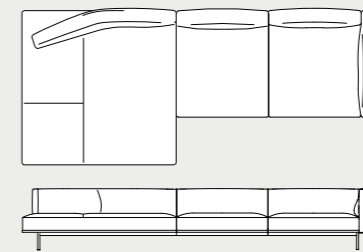
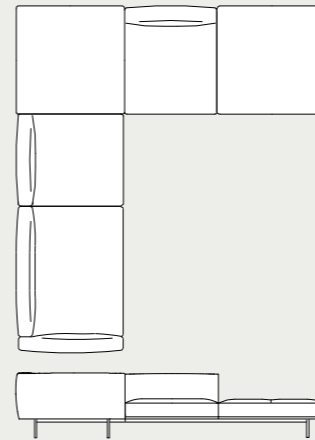

Lefthand ottoman + Central module + Corner ottoman + Central module and end module
L 290 x D 337 x H 62/64 cm
p. — 024-025

Lefthand module 202 + Righthand chaise longue end module
L 352 x D 157 x H 62/64 cm
p. — 032-033

Lefthand module 202 + Righthand chaise longue corner module + Central element + Righthand end module 147
L 352 x D 394 x H 62/64 cm
p. — 028, 030-031

Gould Sofa Collection

These products are part of a System Sofa Collection. More configurations are available.

Questi prodotti fanno parte di un sistema di divani. Sono disponibili altre configurazioni.

Ces produits font partie d'un système de canapés. Ils sont disponibles dans d'autres configurations.

Diese Produkte sind ein Teil des Systems der Sofakollektion. Mehr Konfigurationen sind erhältlich.

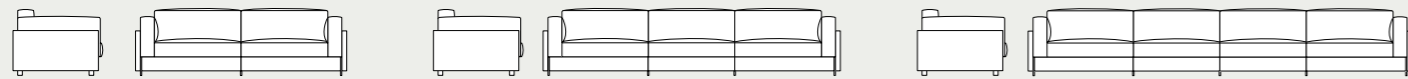

Large Sofa
L 226 x D 95 x H 70 cm

Extra Large Sofa
L 320 x D 95 x H 70 cm
p. — 086-087, 090-091

Extra Extra Large Sofa
L 412 x D 95 x H 70 cm

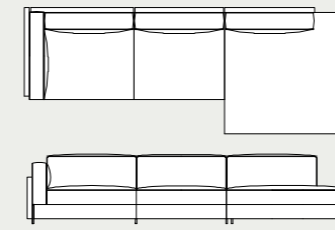

End + 1 intermediate module - right + Chaise longue - left
L 331 x D 130 x H 70 cm
p. — 084

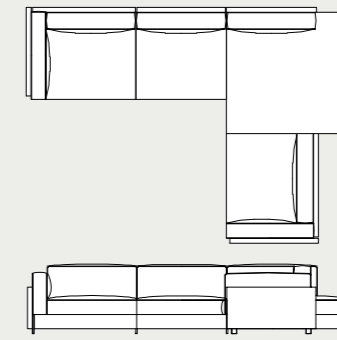

End + 1 intermediate module - right + Chaise longue - left + 1 end module - left
L 331 x D 243 x H 70 cm



Ottoman - Large
L 125 x D 125 x H 38 cm

Ottoman - Medium
L 100 x D 100 x H 38 cm

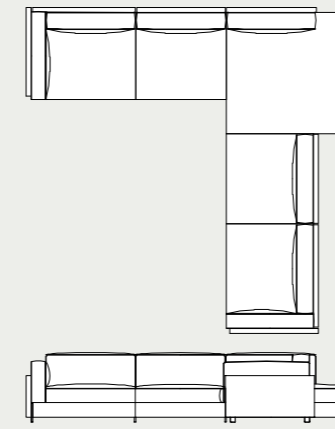

End + 1 intermediate module - right + Chaise longue - left + 1 end + Intermediate module - left
L 331 x D 336 x H 70 cm
p. — 094-095

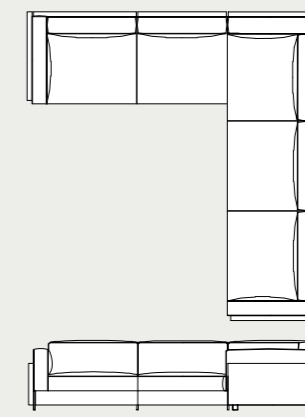

End + 1 intermediate module - right + Chaise longue - left + 1 end module - left
L 331 x D 319 x H 70 cm
p. — 088-089

Avio Sofa System

These products are part of a System Sofa Collection. More configurations are available.

Questi prodotti fanno parte di un sistema di divani. Sono disponibili altre configurazioni.

Ces produits font partie d'un système de canapés. Ils sont disponibles dans d'autres configurations.

Diese Produkte sind ein Teil des Systems der Sofakollektion. Mehr Konfigurationen sind erhältlich.

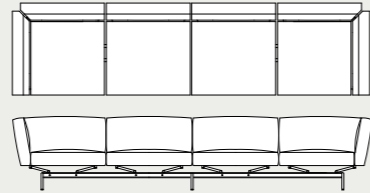
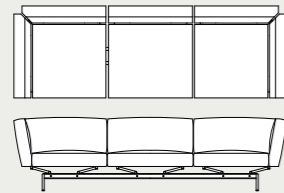
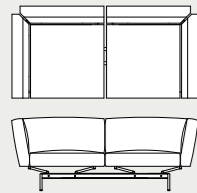

Avio 2 Seater Sofa
L 184 x D 93 x H 72 cm
p. — 100

Avio 3 Seater Sofa
L 271 x D 93 x H 72 cm
p. — 102-103, 112-113

Avio 4 Seater Sofa
L 358 x D 93 x H 72 cm

*Optional Rotating end Mechanism
Right and left

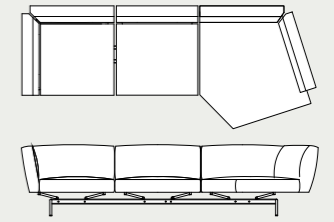
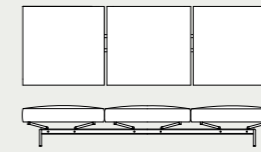
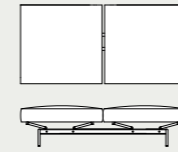

Avio 2 Seater Bench
L 172 x D 87 x H 44 cm - Standard
L 156 x D 79 x H 44 cm - Compact

Avio 3 Seater Bench
L 257 x D 87 x H 44 cm - Standard
L 233 x D 79 x H 44 cm - Compact

Avio 3 Seater Sofa
L 265 x D 93 x H 72 cm

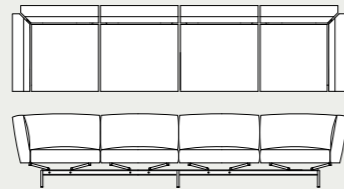
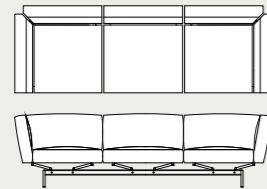
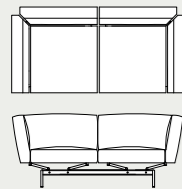

Avio 2 Seater Sofa - Compact
L 170 x D 85 x H 72 cm

Avio 3 Seater Sofa - Compact
L 247 x D 85 x H 72 cm

Avio 4 Seater Sofa - Compact
L 324 x D 85 x H 72 cm

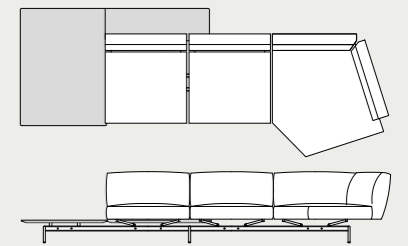
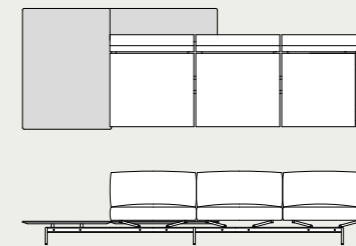
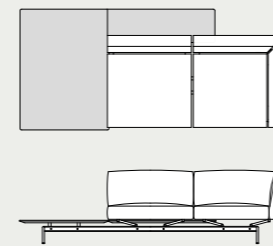

Avio 2 Seater Sofa
+ Left or righthand L-shaped table
L 265 x D 121 x H 72 cm

Avio 3 Seater Sofa
+ Left or righthand L-shaped table
L 352 x D 121 x H 72 cm

Avio 3 Seater Sofa
+ Left or righthand L-shaped table
L 377 x D 146 x H 72 cm

Avio Sofa System

These products are part of a System Sofa Collection. More configurations are available.

Questi prodotti fanno parte di un sistema di divani. Sono disponibili altre configurazioni.

Ces produits font partie d'un système de canapés. Ils sont disponibles dans d'autres configurations.

Diese Produkte sind ein Teil des Systems der Sofakollektion. Mehr Konfigurationen sind erhältlich.

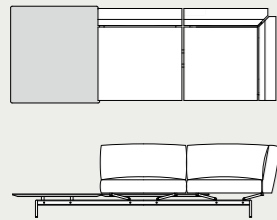

Avio 2 Seater Sofa + Left or righthand table
L 265 x D 93 x H 72 cm

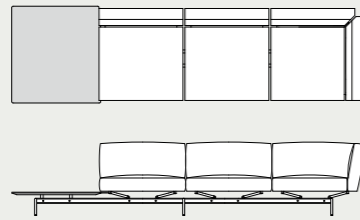

Avio 3 Seater Sofa + Left or righthand table
L 352 x D 93 x H 72 cm
p. — 108-109

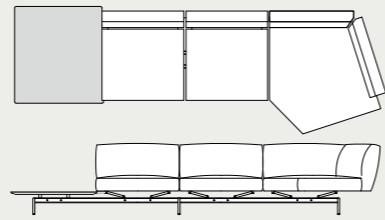

Avio 3 Seater Sofa + Left or righthand table
L 377 x D 128 x H 72 cm

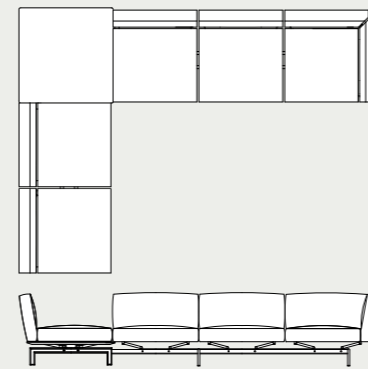

Avio 5 Seater Sofa
+ Left or righthand + Ottoman Corner table
L 356 x D 265 x H 72 cm
p. — 104-105

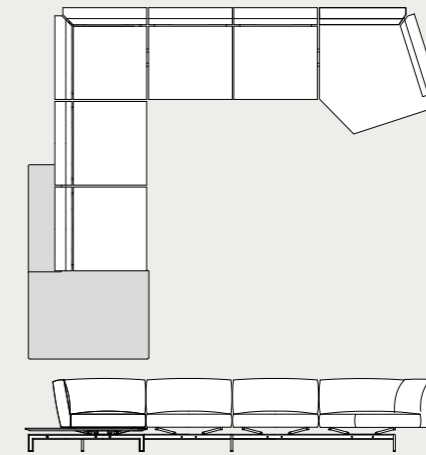

Avio 6 Seater Sofa
+ Left or righthand L-shaped table
L 407 x D 350 x H 72 cm

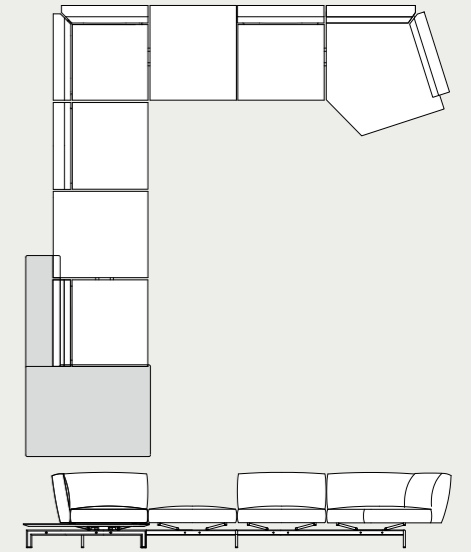

Avio 7 Seater Sofa
+ Left or righthand L-shaped table
L 407 x D 437 x H 72 cm
p. — 110-111

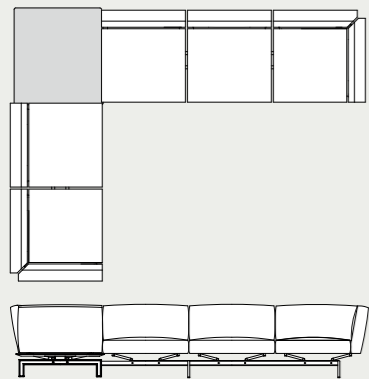

Avio 5 Seater Sofa
+ Left or righthand Corner table
L 356 x D 271 x H 72 cm

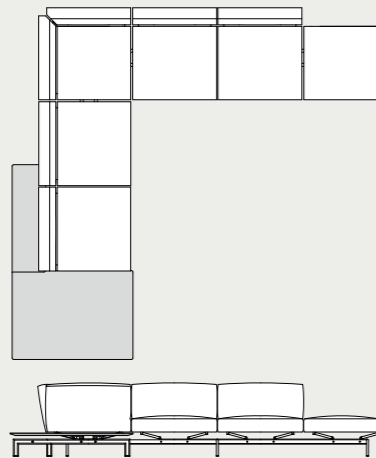

Avio 5 Seater Sofa + Ottoman
+ Left or righthand L-shaped table
L 382 x D 352 x H 72 cm
p. — 108-109

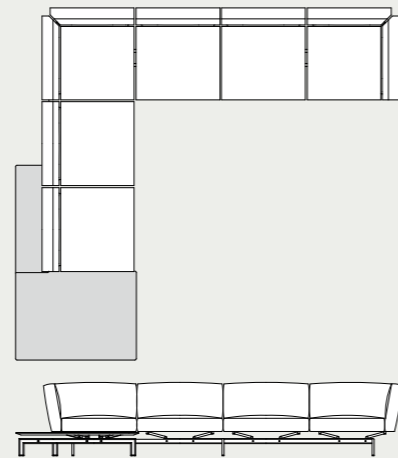

Avio 5 Seater Sofa
+ Left or righthand L-shaped table
L 386 x D 350 x H 72 cm
p. — 114-115

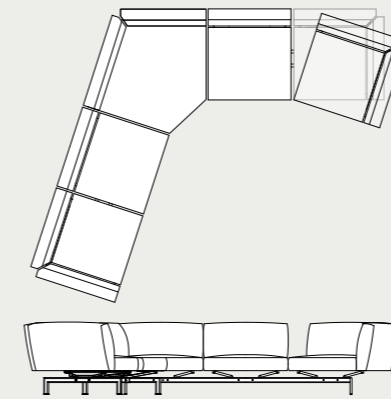

Avio 5 Seater Sofa with rotating
end mechanism
L 356 x D 297 x H 72 cm

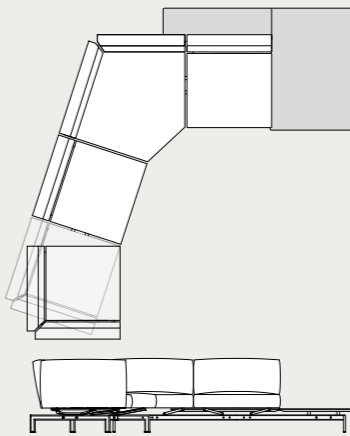

Avio 4 Seater Sofa + Right or left hand
L-shaped table and rotating end mechanism
L 314 x D 294 x H 72 cm

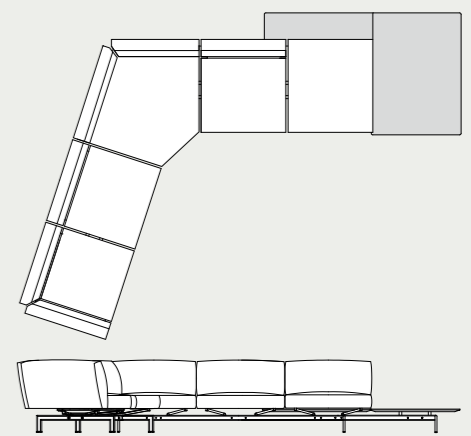

Avio 5 Seater Sofa
+ Right or left hand L-shaped table
L 380 x D 350 x H 72 cm
p. — 106-107

Panoramic System

These products are part of a System Sofa Collection. More configurations are available.

Ces produits font partie d'un système de canapés. Ils sont disponibles dans d'autres configurations.

Questi prodotti fanno parte di un sistema di divani. Sono disponibili altre configurazioni.

Diese Produkte sind ein Teil des Systems der Sofakollektion. Mehr Konfigurationen sind erhältlich.



Panoramic Sofa DX
L 241 x D 118 x H 40 cm



Panoramic Sofa DX
L 241 x D 118 x H 40 cm



Panoramic Sofa
L 146 x D 118 x H 40 cm



Backrest Cushion
L 65 / 82 / 100 x D 31 x H 44/55 cm

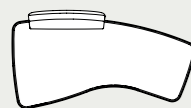

Panoramic Sofa
L 241 x D 126 cm

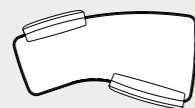

Panoramic Sofa
L 241 x D 126 cm
p. — 074

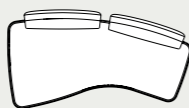

Panoramic Sofa
L 241 x D 126 cm
p. — 070



Panoramic Sofa
L 251 x D 126 cm
p. — 072-073



Panoramic Sofa
L 146 x D 115 cm



Panoramic Sofa
L 156 x D 125 cm
p. — 072-073

Boeri Collection

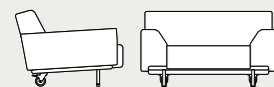

Lounge Chair
L 136 x D 111 x H 77 cm

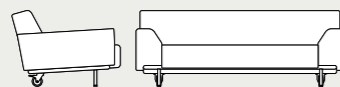

Sofa
L 211 x D 111 x H 77 cm



Ottoman
L 84 x D 84 x H 34 cm

Edward Barber & Jay Osgerby Collection

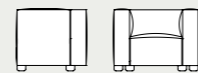

Compact Armchair
L 89 x D 74 x H 63.5 cm



Small Ottoman
L 75 x D 75 x H 38.5 cm



2 Seater Compact Sofa
L 164 x D 74 x H 63.5 cm

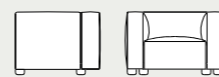

Armchair
L 100 x D 86 x H 63.5 cm



Medium Ottoman
L 90 x D 90 x H 38.5 cm

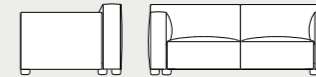

2 Seater Sofa
L 186 x D 102 x H 71.5 cm



3 Seater Sofa
L 216 x D 102 x H 71.5 cm
p. — 180

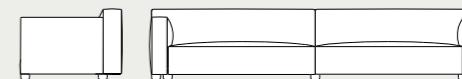

4 Seater Sofa
L 336 x D 102 x H 71.5 cm

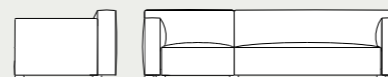

Asymmetric Sofa / Left
L 261 x D 102 x H 71.5 cm
p. — 182-183



Asymmetric Sofa / Right
L 261 x D 102 x H 71.5 cm



Sofa with right Chaise Longue
L 261 x D 102/164 x H 71.5 cm



Sofa with left Chaise Longue
L 261 x D 102/164 x H 71.5 cm
p. — 184-185

Piero Lissoni Collection

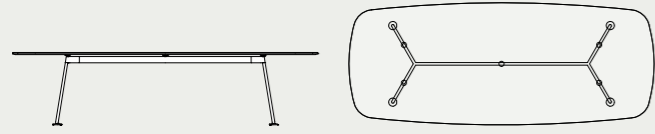

Grasshopper High Rectangular Table
L 300 x D 120 x H 72.5/71.5 cm
p. — 120-121

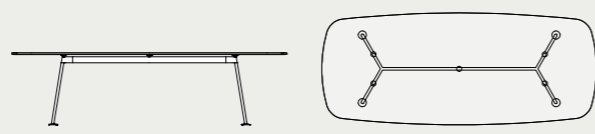

Grasshopper High Rectangular Table
L 270 x D 110 x H 72.5/71.5 cm
p. — 046, 130-131

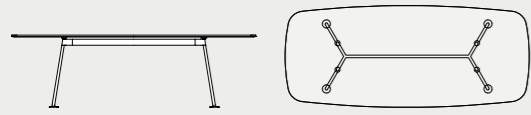

Grasshopper High Rectangular Table
L 240 x D 100 x H 72.5/71.5 cm
p. — 129, 132



Grasshopper High Rectangular Table
L 200 x D 90 x H 72.5/71.5 cm
p. — 116

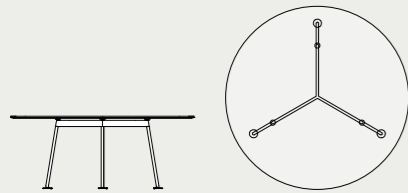

Grasshopper High Round table
Ø 180 x H 72.5/71.5 cm

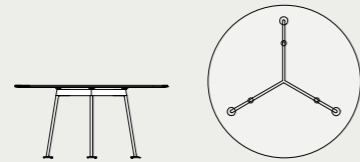

Grasshopper High Round table
Ø 152 x H 72.5/71.5 cm



Grasshopper High Round table
Ø 137 x H 72.5/71.5 cm
p. — 125

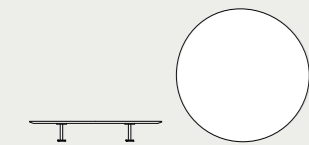

Grasshopper Low Table
Ø 137 x H 20 cm
p. — 094-095

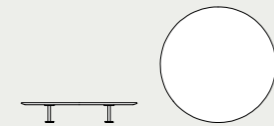

Grasshopper Low Table
Ø 120 x H 20 cm

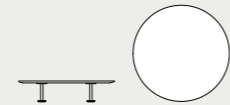

Grasshopper Low Table
Ø 100 x H 20 cm

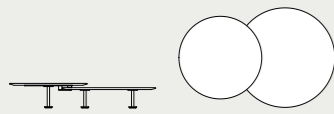

Grasshopper Low Table Set
Ø 100/83 x H 20/25 cm
p. — 038-039, 090-091

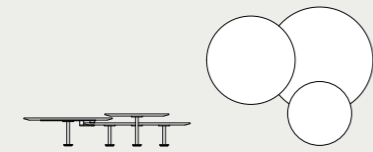

Grasshopper Low Table Set
Ø 137/120/70 x H 20/25/30 cm
p. — 106-107, 110-111, 126, 127

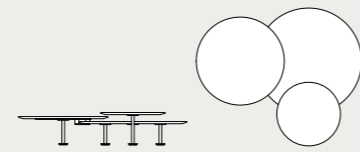

Grasshopper Low Table Set
Ø 100/83/60 x H 20/25/30 cm

Citterio Collection

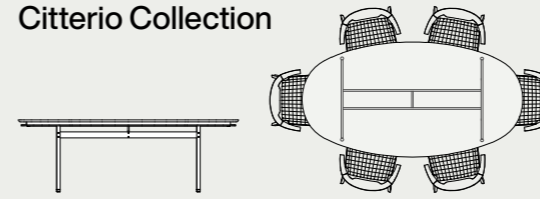

High Table
L 220 x D 115 x H 71/72 cm
p. — 156-157

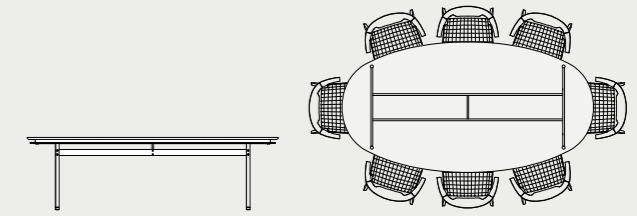

High Table
L 250 x D 130 x H 71/72 cm

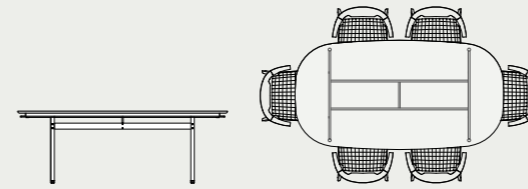

High Table
L 210 x D 110 x H 71/72 cm
p. — 154

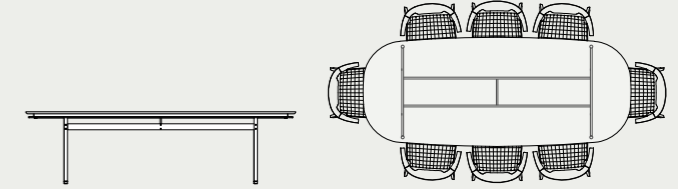

High Table
L 270 x D 110 x H 71/72 cm



Low Table
L 130 x D 90 x H 42/43 cm

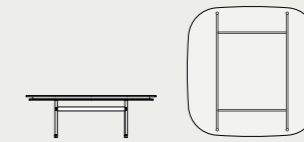

Low Table
L 130 x D 130 x H 42/43 cm
p. — 160-161



Low Table
L 180 x D 90 x H 42/43 cm

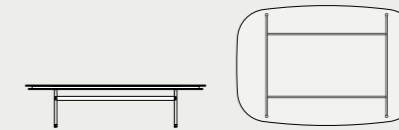

Low Table
L 180 x D 120 x H 42/43 cm



Console
L 177 x D 46 x H 60/61 cm
p. — 155



Side Table
L 60 x D 60 x H 42/52 cm



Side Table
L 45 x D 45 x H 42/52 cm
p. — 159

Panoramic Low Table

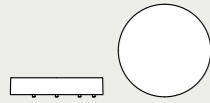

Panoramic Low Table
Ø 90 x H 19.5 cm
p. — 070, 072-073, 074

Gehry Collection

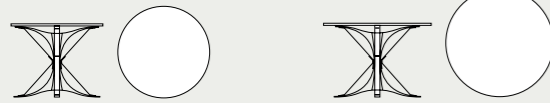

Face Off Table
Ø 92 x H 73 cm
p. — 162

Face Off Table
Ø 102 x H 73 cm

Marc Krusin Collection

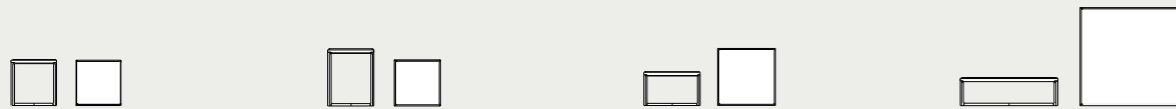

Side Table
L 45 x D 45 x H 45.7 cm
p. — 190

Side Table
L 45 x D 45 x H 55.7 cm
p. — 190

End Table
L 60 x D 60 x H 35.7 cm
p. — 190

Coffee Table
L 90 x D 90 x H 25.7 cm
p. — 190

Piton Table



Piton Table
Ø 51 x H 54.2 cm

Lucia Mercer Stump Table



Stump Table
L 55 x D 33 x H 38 cm

Lissoni Collection

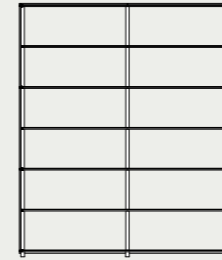

Red Baron 2 modules
L 200 x D 45 x H 240 cm
p. — 064-065

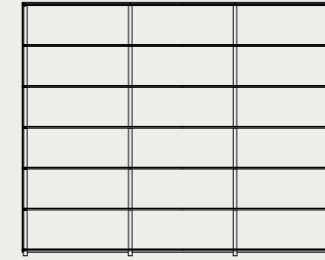

Red Baron 3 modules
L 300 x D 45 x H 240 cm

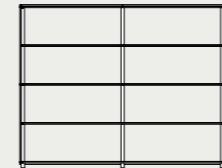

Red Baron 2 modules
L 200 x D 45 x H 160 cm

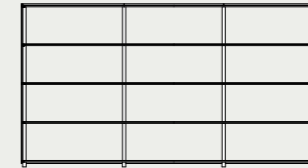

Red Baron 3 modules
L 300 x D 45 x H 160 cm
p. — 096, 098-099



Matic Credenzas
L 180 x D 65 x H 40.5 cm
p. — 078

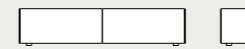

Matic Credenzas
L 180 x D 65 x H 40.5 cm
p. — 076, 080

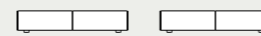

Matic Storage Units
L 120 x D 119.4 x H 24 cm
p. — 083



Matic Storage Units
L 160 x D 60 x H 24 cm
p. — 080

Piero Lissoni Outdoor

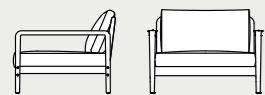

Armchair
L 101.5 x D 91 x H 76 cm
p. — 134, 138

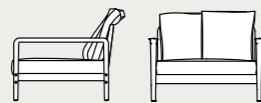

Armchair
L 101.5 x D 91 x H 76 cm

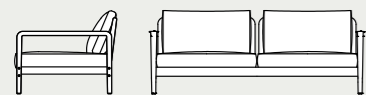

Two-Seat Sofa
L 191 x D 91 x H 76 cm

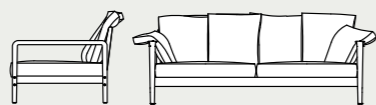

Two-Seat Sofa
L 191 x D 91 x H 76 cm

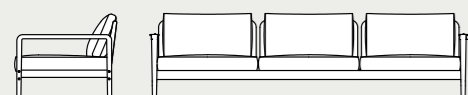

Three-Seat Sofa
L 280.5 x D 91 x H 76 cm
p. — 139

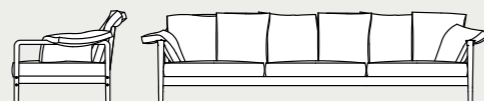

Three-Seat Sofa
L 280.5 x D 91 x H 76 cm
p. — 134, 136-137

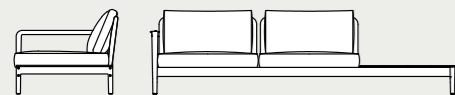

Asymmetrical Sofa - Right
L 269 x D 91 x H 76 cm

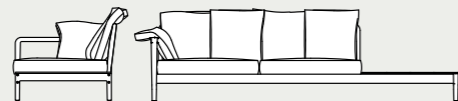

Asymmetrical Sofa - Right
L 269 x D 91 x H 76 cm
p. — 136

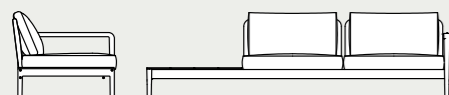

Asymmetrical Sofa - Left
L 269 x D 91 x H 76 cm

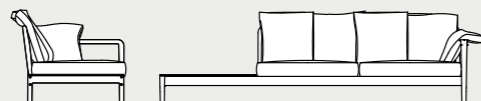

Asymmetrical Sofa - Left
L 269 x D 91 x H 76 cm

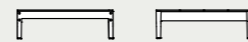

Low Table
L 85 x D 85 x H 26 cm



Low Table
L 85 x D 170 x H 26 cm
p. — 136-137



Stool / Low Table
Ø 42 x H 40.5 cm
p. — 134, 138

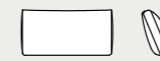

Back Cushions
L 75 x H 40 cm

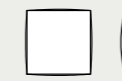

Back Cushions
L 55 x H 55 cm



Knoll. The Original Design

KnollStudio Customer Service

Knoll International
Via S. Colombano, 67
I - 26813 Graffignana - Lodi - Italy
customerservice@knolleurope.com

Benelux

KnollStudio Customer Service
Tel: +32 (0)2 715 13 03

France

KnollStudio Customer Service
Tel: +33 (0)1 44 18 19 92

Germany

KnollStudio Customer Service
Tel: + 39 0371 2069 262

Austria & Switzerland

KnollStudio Customer Service
Tel: +39 0371 2069 270

Italy

KnollStudio Customer Service
Tel: +39 0371 2069 272

Scandinavia

KnollStudio Customer Service
Tel: +39 0371 2069 271

United Kingdom

KnollStudio Customer Service
Tel: +39 0371 2069 266

Spain & Portugal

KnollStudio Customer Service
Tel: +39 0371 2069 266

Knoll International EMEA

(excluding above mentioned
countries)

KnollStudio Customer Service

Tel: +39 0371 2069 271

Asia - Pacific

KnollStudio Customer Service
Tel: +39 0371 2069 208

Knoll Showrooms

Paris

268 Boulevard Saint Germain
F - 75007 Paris
Tel: +33 (0)1 44 18 19 99

Milano

Piazza Bertarelli 2
I - 20122 Milano
Tel: +39 02 7222 291

London

91 Goswell Road
UK - EC1V7EX London
Tel: +44 (0) 20 7236 6655

USA

Knoll Inc.
1330 Avenue of the Americas
10019 New York

U. S. A.

Tel: +1 212 343 40 00

*Art direction
and graphic design
Designwork*

Photography

Federico Cedrone
Gionata Xerra
Santi Caleca
Knoll Archive
Ilan Rubin
©Joshua McHugh
Massimo Gardone
Sandro Paderni
Beppe Brancato

Styling

Vandersandestudio

Colour separation

Lucegroup

Set in Helvetica Now Display

medium / medium italic / bold

Printed in Italy

By Poligrafiche San Marco
February 2024

Thanks to

Alberto Levi Gallery
Alpi
Altai
Amini Carpets
Amleto Missaglia
Antichità San Marco
Arik LEVY
Astep
Atelier Areti
B.F.A. Benedetto Fasciana
Barbara Schweizer
Bernard Pages
Books Import
Camp Design Gallery
Ceramiche Milesi
Dep Art Gallery
Edizioni Design
Eligo
Émile Gilioli
Federica Bubani ceramics
Flos
Galleria l'Affiche
Giuliano Gaigher
Glas Italia
Golran
Good Morning Studio
Gumdesign
Ignacio Uriarte, 4x4 Single Line
Ilaria Franza
Isabella Nurigiani
Kose Milano
Laboratorio Paravicini
Labyrinths #1, 2008
Loro Piana
Marco Solzi paintings
Martina Geroni
Mercatino Penelope
Metalli Filati
MMario
Natale Addamiano
Nemo
Officina Antiquaria
Officine Saffi
Oluce
Paola Paronetto
Pescetta Antichità
Potafiori
Sabine Pagliarulo
Sahrai Milano Luxury Rugs
Salvatori
Society Limonta
Studio 2046
Studio Dimore Collection
Teakfurniture
The Silk Road Collection
Usò Interno
Venetia Studium
When Objects Work
Wunderkammer Studio
Yali Glass

