

kettal

Outdoor

4–55

Tilos by Antonio Citterio

56–67

Loden by Vico Magistretti

68–101

Passage by Ronan Bouroullec

102–109

Kari by Konstantin Grcic

110–115

Insula by Patricia Urquiola

116–121

Anda by Gonzalo Milá & Miguel Milá

122–131

Soga rugs by Vincent Van Duysen

Workplace

132–163

Pi by Kettal Studio

Materials

164–171

Finishes

Tilos by Antonio Citterio

The Tilos Collection takes inspiration from the archetypal seating of the 1950s and 1960s, traditionally crafted in bamboo and rattan. These forms have been reimagined using advanced technologies and modern industrial manufacturing techniques, resulting in a collection that feels both timeless and contemporary.

At its core, Tilos features a distinctive shell made of metal and woven acrylic rope, designed to cradle plush cushions while ensuring both comfort and durability. This shell rests on a structural frame available in either wood or metal, offering a refined and versatile foundation. The design seamlessly allows for the interchangeability of these base materials, adapting to different aesthetic and functional needs.

The collection also includes dining chairs available in two versions—one stackable for greater flexibility and another with armrests for enhanced comfort.

With Tilos, the goal was to merge tradition and innovation, seamlessly blending artisanal references with the precision of contemporary industrial craftsmanship to create pieces that integrate effortlessly into modern spaces.

















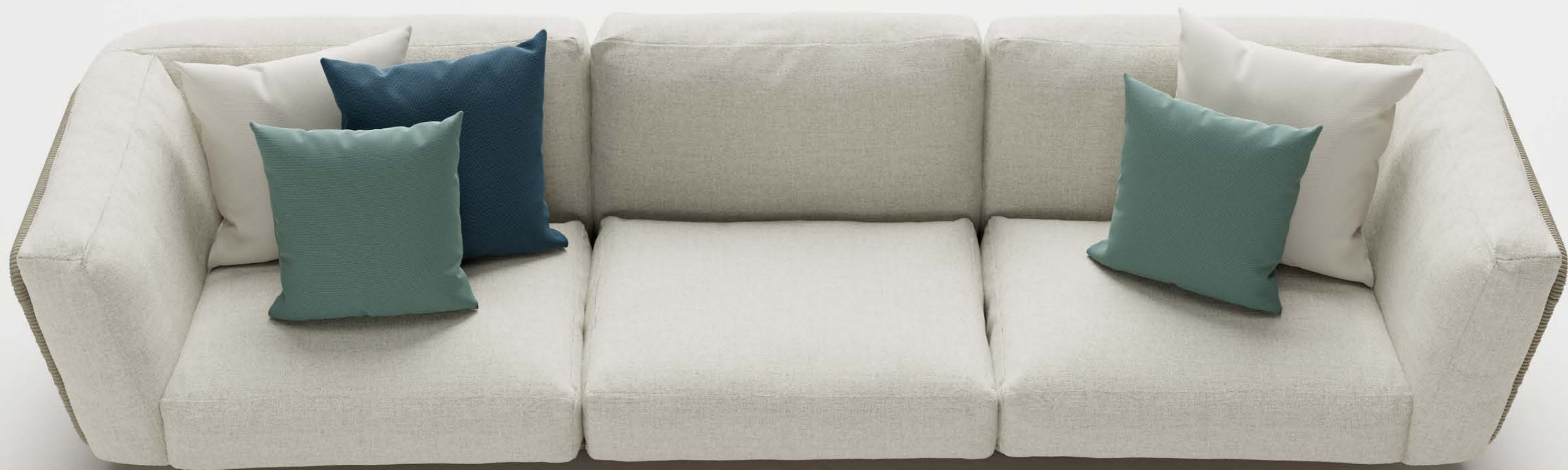

































Dining armchair

KSB700100

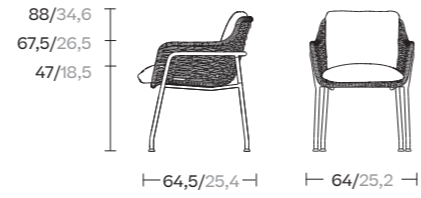

Stackable dining armchair

KSB700200



Club armchair

KSB700300

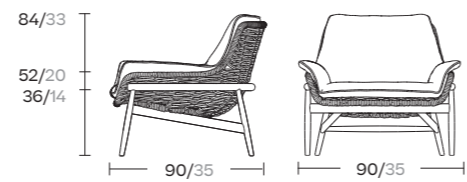

2-seater sofa

KSB700400

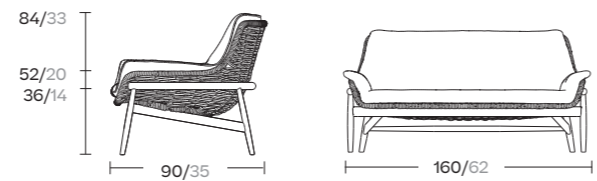

Dining table 107x300

KSB703200

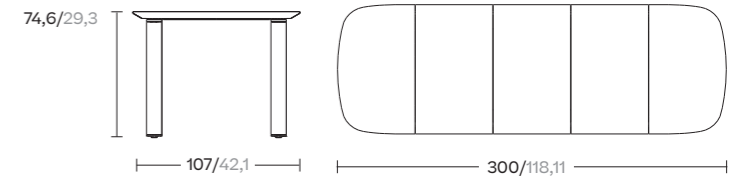

Dining table 107x240

KSB703400

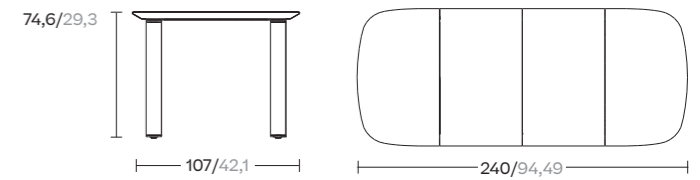

Centre table 107 x 240
Centre table 107 x 180

KSB705300 - 107x240
KSB705600 - 107x180

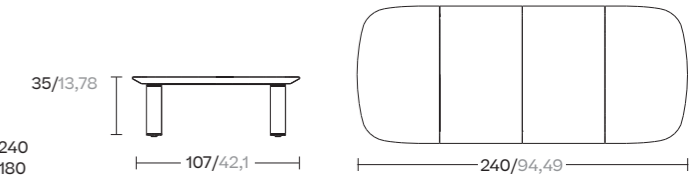

Centre table 107 x 120

KSB705100

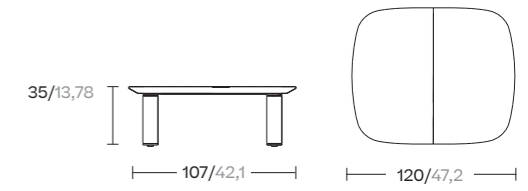



Right module

KSB500500

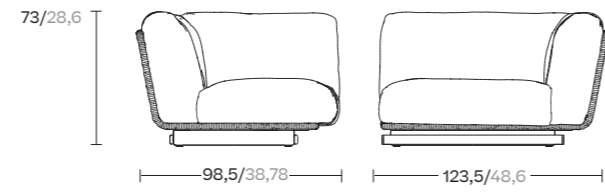

Left module

KSB500600

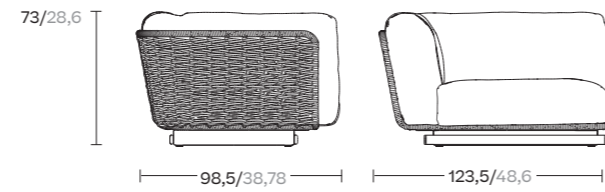

Right module without armrest

KSB500600

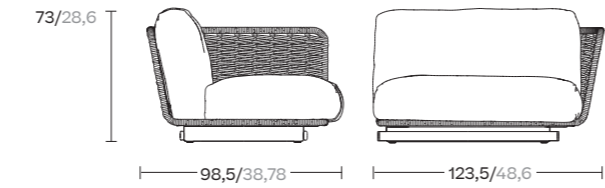

Left module without armrest

KSB500600

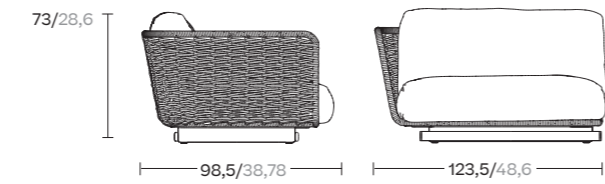

Central module

KSB500100

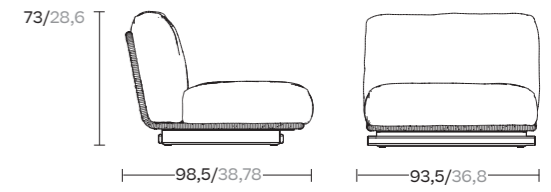

Chaise Lounge module

KSB500200

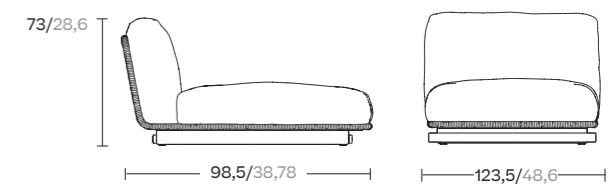

Loden, by Vico Magistretti

Kettal revives the LODEN collection. Originally designed for Gavina in 1961, Loden is a series featuring an armchair and a sofa with a lacquered wood frame made with four cylinder-section legs and a tilted seat, also made of wood, with curved armrests whose design is similar to the profile of the armrests of the Carimate chairs. The seat and backrest are upholstered in fabric. Dino Gavina, a Bolognese businessman, started

producing new furniture in the mid-50s by collaborating with well-known designers and put back into producing furniture by Breuer, a renowned designer in NY, like the Cesca and Wassily chairs. The Loden series by Magistretti is part of the collections produced by Gavina in the 60S”













Outdoor Club armchair
Teak

KSC100100

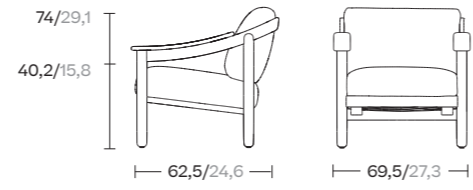

Indoor Club armchair
Oak

KSC100300

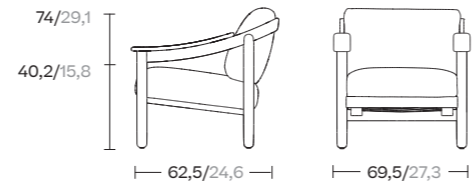

Indoor Club armchair
Red Sixties edition

KSC100500

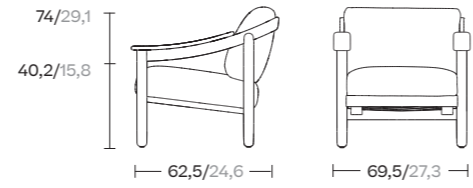

Indoor Club armchair
Black Sixties edition

KSC100600

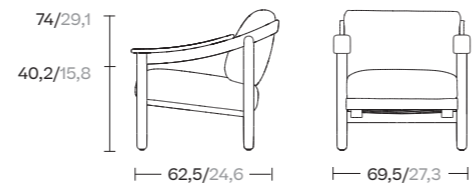

Passage, by Ronan Bouroullec

Passage is a multi-purpose word.

It can be found in many spheres, from travel to literature and music. It suggests movement, fluidity and transition from one place to another. The Passage collection is no less versatile.

Seamlessly moving from one place to another, it can be installed indoors or outdoors, displayed in a public space such as a café terrace, or discreetly placed at home, in an urban or natural setting.

At first sight, the collection seems simple enough. But when we look at the details, we realize the technical sophistication of this chair, the high quality of the welds, the precision of the joints and the finesse of the backrest.



































Sofa

KSB600700

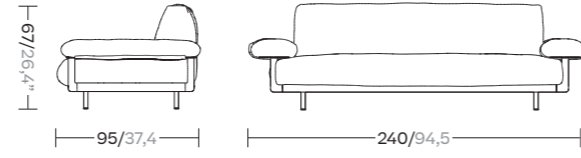

2-seater Bench
3-seater Bench

KSB504000 - 2-seater bench
KSB504200 - 3-seater bench

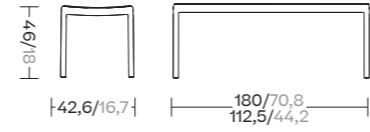

Bar stool

KSB601100

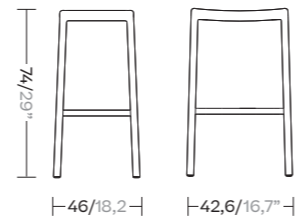

Stool

KSB601100

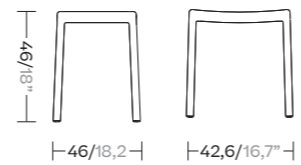

Stackable dining chair

KSB500100

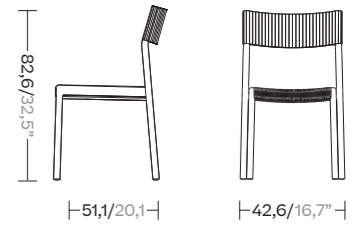

Stackable dining armchair
Non-stackable dining armchair

KSB500400 - Stackable
KSB500500 - Non stackable

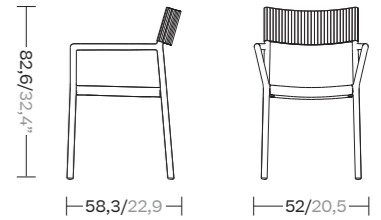

Stackable Club armchair

KSB501300

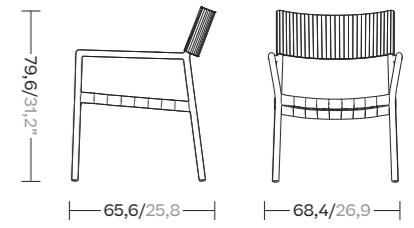

Centre table 80x80

KSB600800

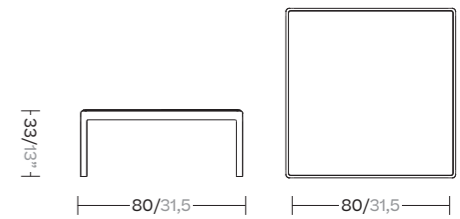

Kari, by Konstantin Grcic

Designed by Konstantin Grcic, the Kari collection features a pair of highly versatile side tables that can be combined in countless ways. While both tables share a circular top, their bases explore two distinct geometries: cylinders and pyramids.

Currently available in teak wood, their clever construction allows for a wide variety of materials to be used. The geometric

shapes lend the pieces an elegant, African-inspired character and a natural aesthetic.

Kari tables serve as practical side tables or occasional seating next to a sofa or armchair. Their lightweight design makes them easy to move around as needed.







Kari





Side table d40

KSC300100

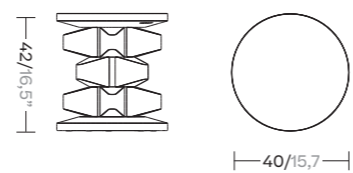

Side table d48

KSC300200

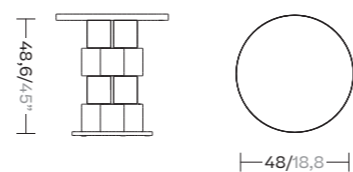

Insula tables

Designed as sculptural islands, Ínsula tables by Patricia Urquiola find their identity in the delicate balance between the organic and the refined. Each piece stands as an autonomous object, capable of interacting with its surroundings through its unique presence.

The tabletop, finished in Glaze Agate —a glaze with hypnotic depth and mineral tones— brings a rich, sensory dimension to the piece. Its surface, layered with subtle variations, evokes geological formations and natural processes, as if time itself had crystallized in ceramic.

Soft, fluid lines contrast with the visual density of the glaze, creating a dialogue of textures that invites both touch and contemplation. More than a table, Ínsula is a material experience — a meeting point between contemporary craftsmanship and poetic design.







Dining table 260x110

B670400040

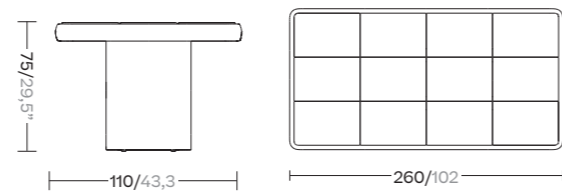

Dining table 210x110

B670400030

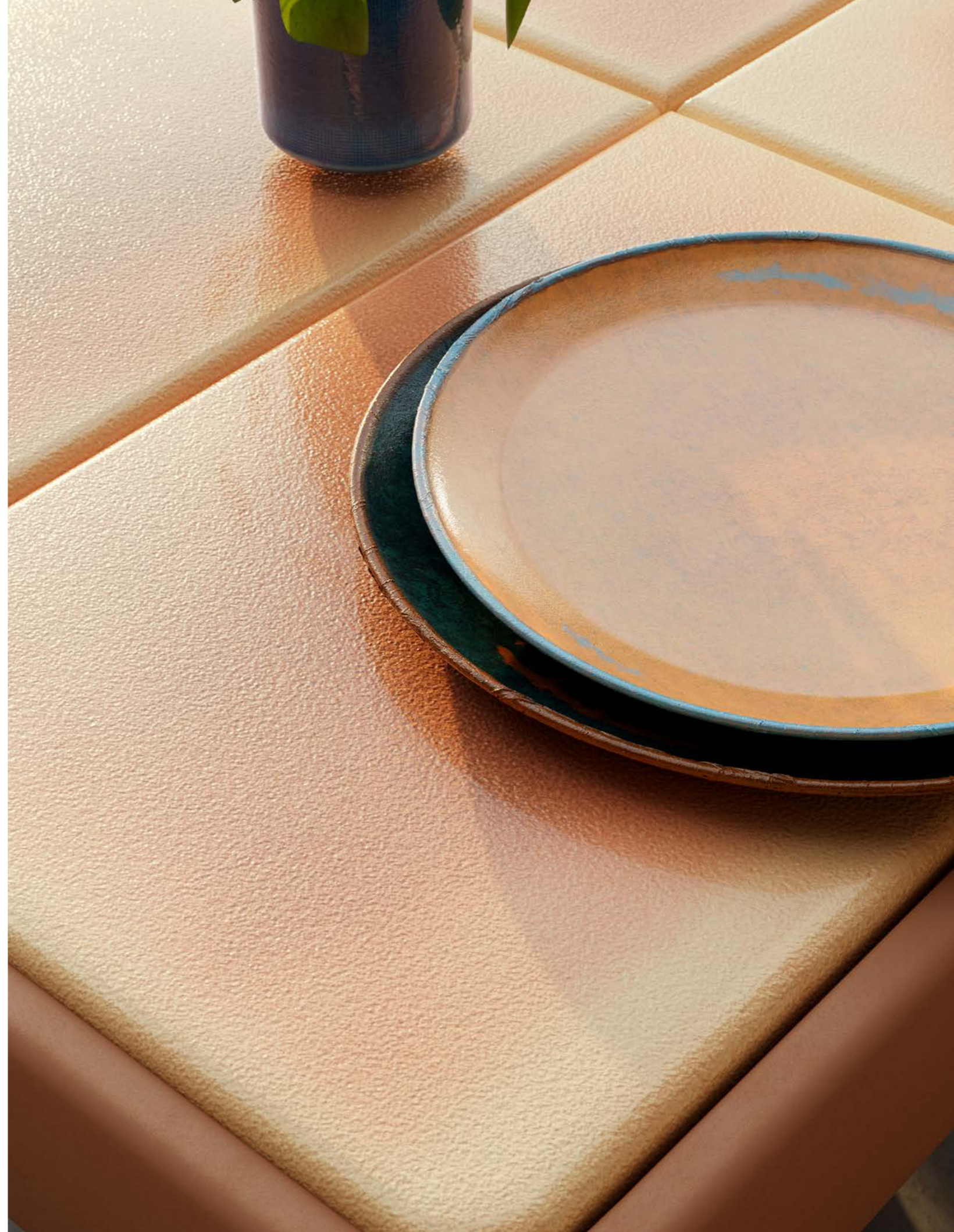
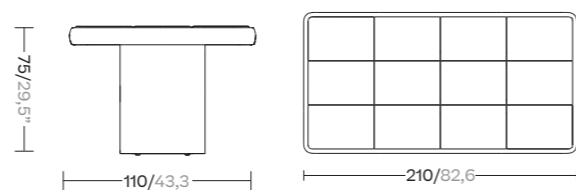

Anda by Gonzalo & Miguel Milà

There are moments at the end of the day when you just want to sit outside—on a terrace, somewhere beyond the reach of electrical outlets—and enjoy the absence of overhead lighting in your line of sight.

ANDA is a cylindrical floor lamp with a pared-down, versatile design, conceived to adapt to a wide range of settings. It directs light downward to control dispersion, making it ideal for illuminating an indoor or outdoor lounge area, or a quiet reading corner.

Its medium height and refined design provide comfortable lighting without glare. Portable and dimmable, ANDA allows you to adjust the atmosphere to suit the moment—from a subtle glow to safely move around, to a more focused beam for seated tasks.

High-quality materials and meticulous craftsmanship ensure durability and resistance over time.







Outdoor lamp

KSB900100

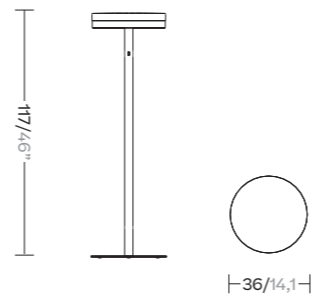

Water and pollution protection: IP 65
Charging connector type: USB C
Compatible with KODE & Matter
CE and UL Certifications
Cable included 2m

Light quality: CRI < 90
Light temperature: 2700K
Battery life: 5-6 hours full power



Soga Rug by Vincent Van Duysen

The Soga rugs by Vincent Van Duysen combine natural texture with a simple, balanced design. Made from a rope-like material, they offer a sturdy and comfortable surface suitable for both indoor and outdoor use. Available in four colors — Ivy, New Dawn, Chestnut, and Woodland — the rugs come in two versions: plain or with subtle stripes. Their understated palette and clean lines make them easy to integrate into a variety of spaces.









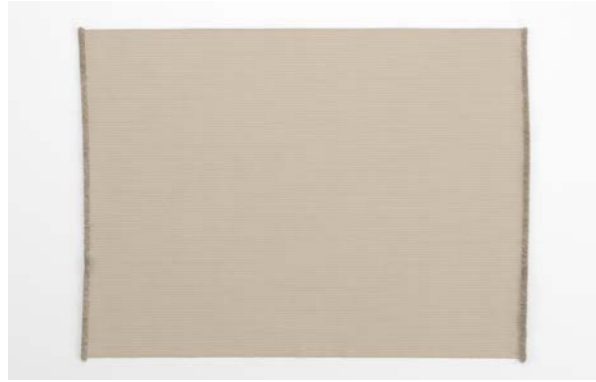

New Dawn

Soga Rug 4x3- 7499000343
Soga Rug 4x4- 7499000344
Soga Rug 6x4 - 7499000364

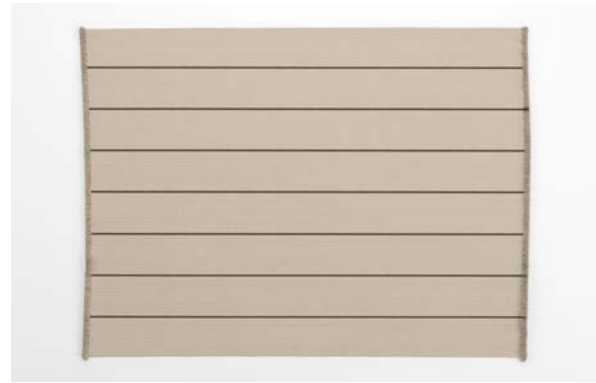
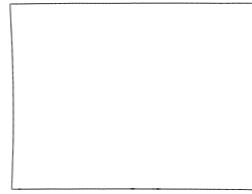

New Dawn stripes

Soga Rug 4x3- 7499000343
Soga Rug 4x4- 7499000344
Soga Rug 6x4 - 7499000364

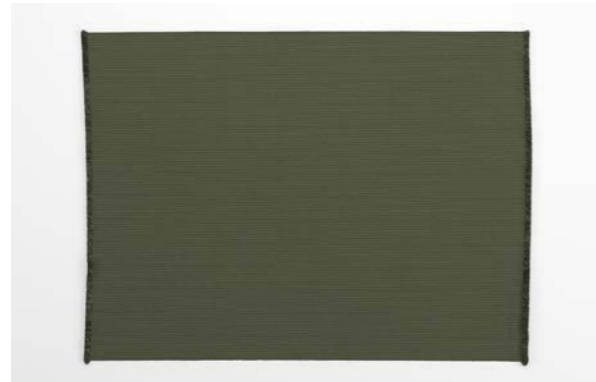
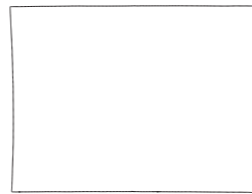

Ivy

Soga Rug 4x3- 7499000343
Soga Rug 4x4- 7499000344
Soga Rug 6x4 - 7499000364

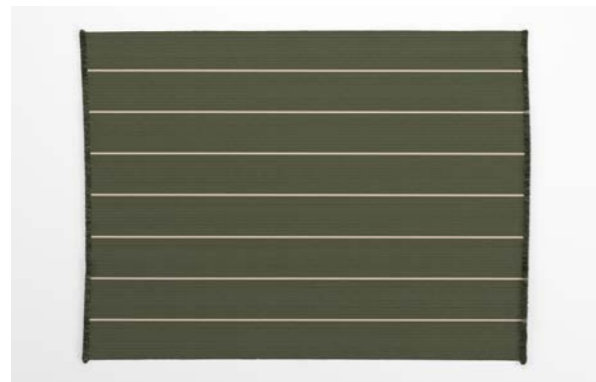
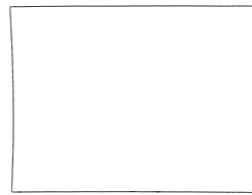

Ivy stripes

Soga Rug 4x3- 7499000343
Soga Rug 4x4- 7499000344
Soga Rug 6x4 - 7499000364

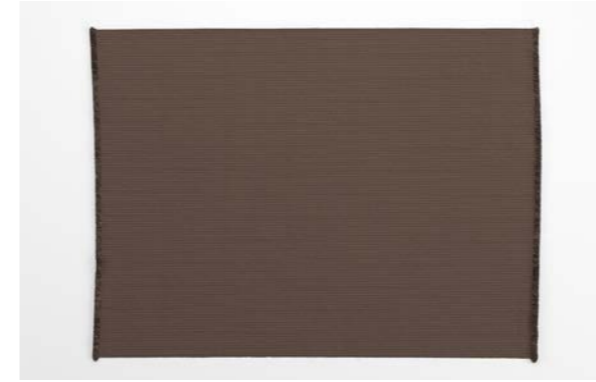
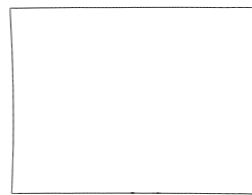

Chestnut

Soga Rug 4x3- 7499000343
Soga Rug 4x4- 7499000344
Soga Rug 6x4 - 7499000364

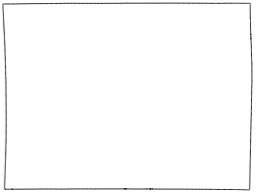

Chestnut stripes

Soga Rug 4x3- 7499000343
Soga Rug 4x4- 7499000344
Soga Rug 6x4 - 7499000364

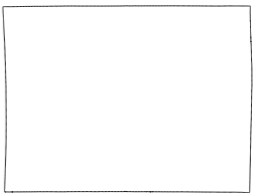

Woodland

Soga Rug 4x3- 7499000343
Soga Rug 4x4- 7499000344
Soga Rug 6x4 - 7499000364

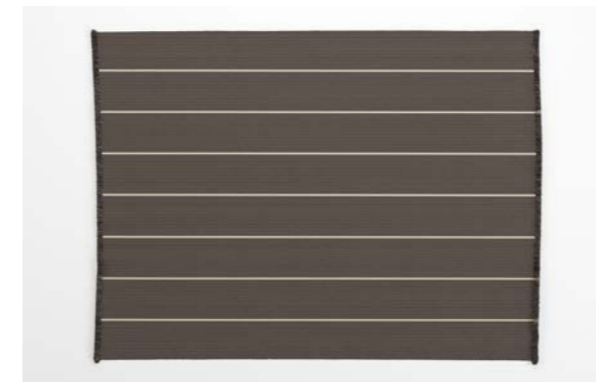
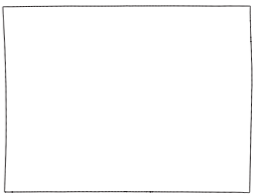

Woodland stripes

Soga Rug 4x3- 7499000343
Soga Rug 4x4- 7499000344
Soga Rug 6x4 - 7499000364

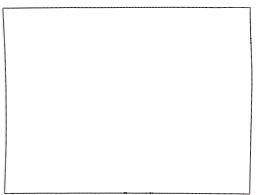

Pi

Pi is an innovative micro-architectural system designed to redefine the work environment. Its flexible structure creates distinct areas within the office, providing spaces where people can isolate themselves from the general surroundings to meet or work without the need for closed doors.

Unlike traditional rigid office planning, Pi offers a simple yet multifunctional furniture system, allowing the freedom to design the optimal space for each task. Its configurations are grouped into three main categories: Focus, for concentrated work; Meet, for communication and idea exchange; and a third adaptable option for other functional needs, such as printing stations, kitchen areas, and more.

Pi not only helps define spaces but also enhances acoustic comfort by reducing noise and absorbing disruptive sounds from the environment. Its units can be spontaneously used as phone booths, video conferencing rooms, reading corners, quiet coffee

spots, or meeting rooms—without the need for enclosed spaces.

Its orthogonal “H” shape design allows for easy spatial structuring. Installation is quick and seamless, without generating noise or altering the building structure. Additionally, the units can be combined, expanded, or adjusted to accommodate changing workspace needs.

Pi is made from recycled PET panels, a lightweight yet durable material that not only helps reduce noise but also adds a sophisticated aesthetic and a pleasant textile-like feel. With its versatile design and sustainable approach, Pi transforms the concept of office spaces into a more flexible, dynamic, and functional environment. It helps reduce noise but also adds a sophisticated aesthetic and a pleasant textile-like feel. With its versatile design and sustainable approach, Pi transforms the concept of office spaces into a more flexible, dynamic, and functional environment.















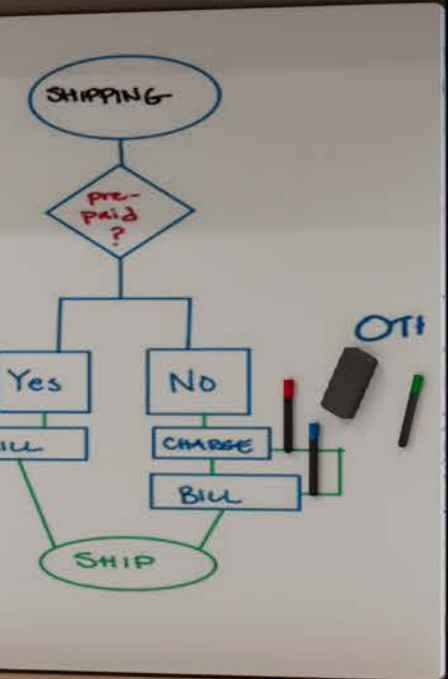



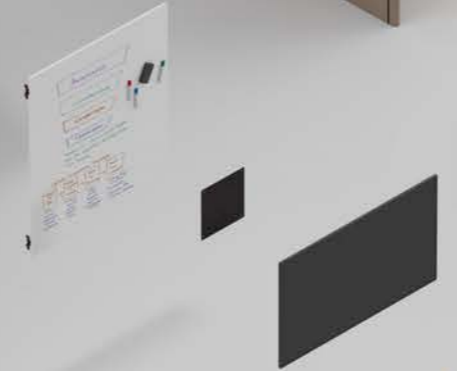
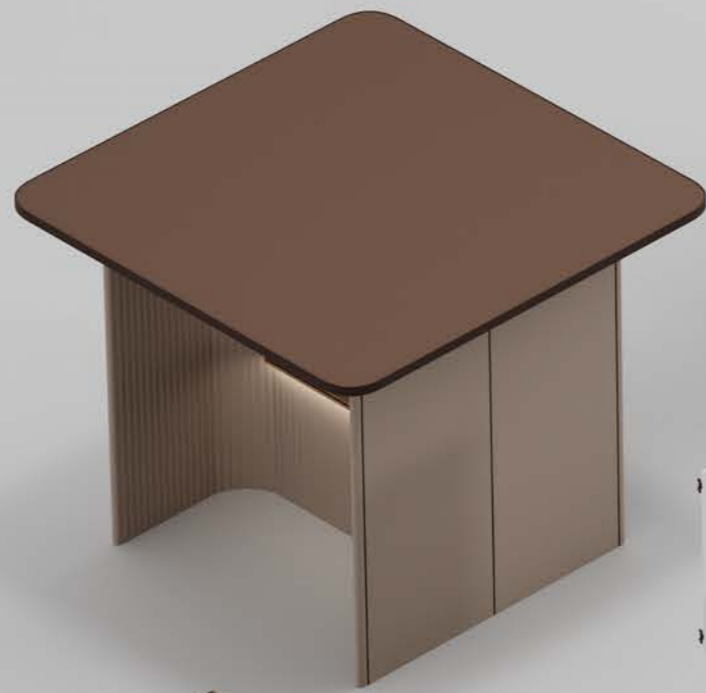



Features

Recycled Materials



Made with sustainability in mind, the PI space divider features PET materials and 95% recycled aluminum—an eco-conscious solution for modern spaces.

Acoustic panel

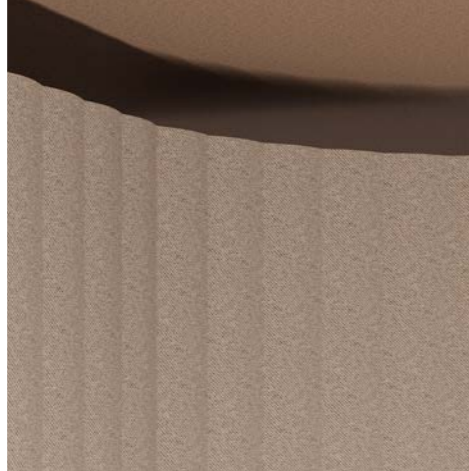

Designed for sound absorption, the acoustic panels feature wave-shaped surfaces that help reduce noise and enhance comfort in shared spaces.

Acoustic ceiling



Inmerge in Peaceful natural day light casacde. Turn the night into a harmonious dance of stars

AirGlow (Phone Booth)



A good air renewal system provides comfort and well-being. A thin layer of air from above refreshes the air in the cabin. A laminar of light from below bathes the wall and work area.

SkyLight (Phone Booth)



Inmerge in Peaceful natural day light casacde. Turn the night into a harmonious dance of stars

FlexTrack



The FlexTrack system offers versatile rail-mounted functionality, allowing you to attach shelves, hooks, magnetic boards, and more—adapting seamlessly to your changing needs

Analog Controller



Analog controls let you adjust lighting with precision, while the PIR sensor adds smart automation by detecting presence

Connectivity



Includes four built-in power outlets for convenient device charging and seamless workspace integration.

Controls (Phone Booth)



Plug USB-A / USB-C / shelf light dimmer, fans power regulator

Integrated wheels



Equipped with discreet wheels and a built-in leveler, PI moves easily and stays firmly in place—flexibility without compromising stability.

Watch the collection video here and discover all its features in action.



Front



Work Desk



Sideboard Kitchen



Printing station



Lounge area relax



Lounge area formal



Swivel chairs

Side



Lounge



Magnetic Board + stools



Hanger



Shelves



Magazines



Tv

Inside



Lounge



Working desks



Audiovisual zone



Videocall area

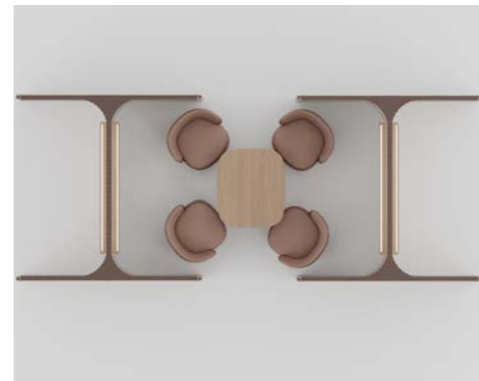

Meeting

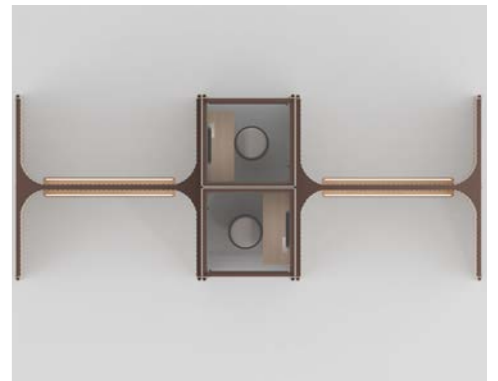

Phone Booths



System structure

KSB800300

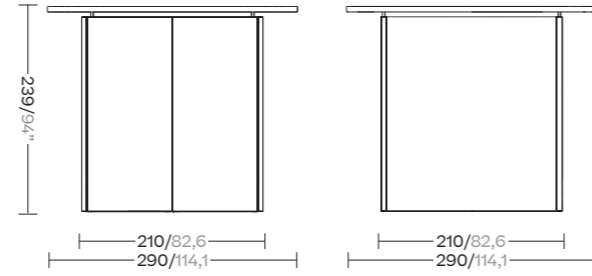

Phone Booth S Pi

B8PB107700

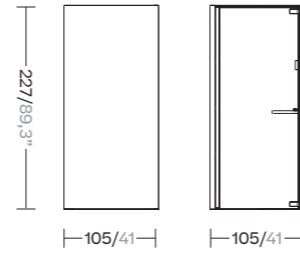

Phone Booth L Pi

B8PB207700

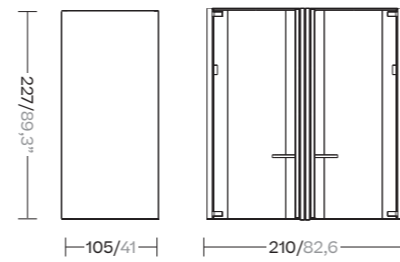

Stool

B836085F00

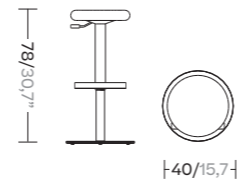

Pouf

B848086M00

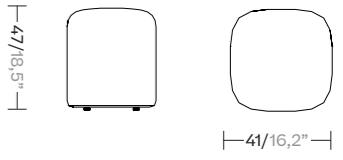

Swivel Chair

B820093200

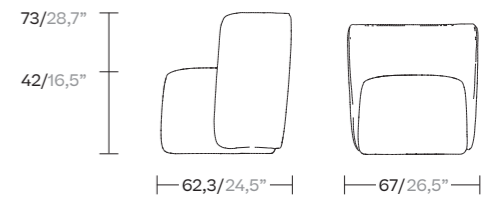

Left Sofa

B84391ZQ0H

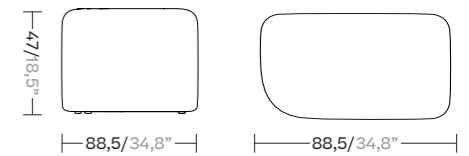

Right Sofa

B8439DER0H

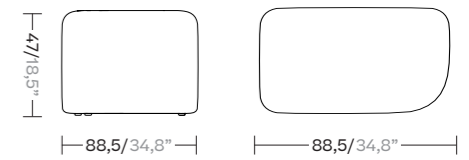



Adjustable table
73 / 49 mm - 28,7 / 19,2 mm

B872393300

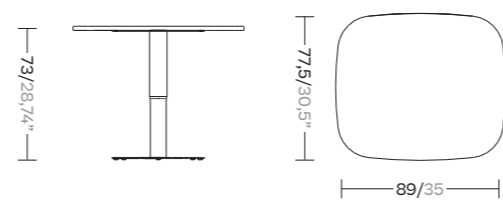

Side table

B873086F10

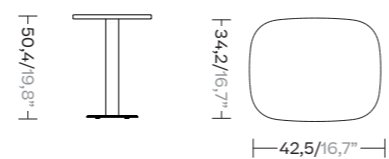

Side Board / Kitchen

B878093300

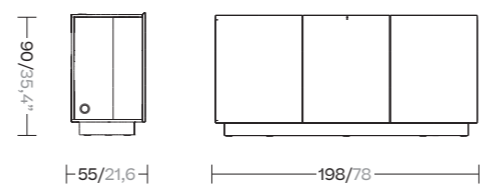

Desk

KSB800100

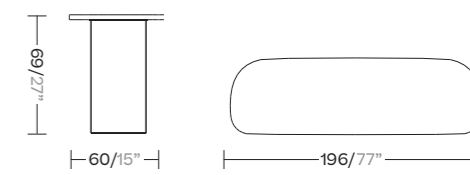

Bench

KSB800200

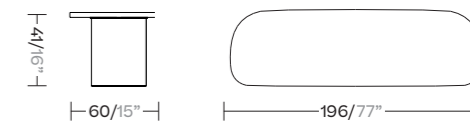

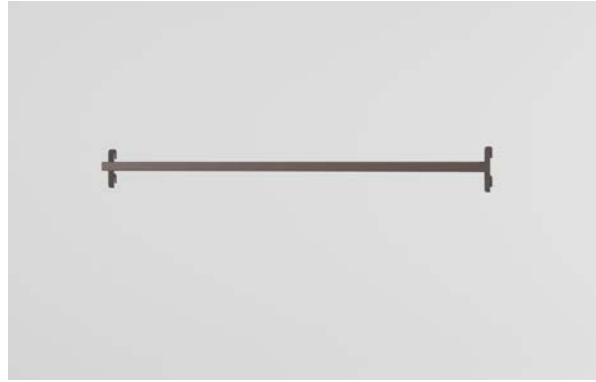

Magnetic bar

B8EST93300

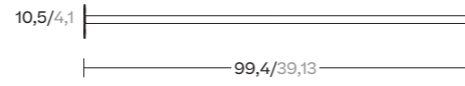

Mini Shelf

B8EST93300

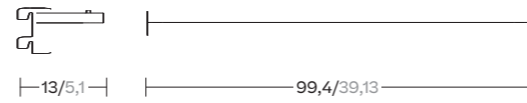

Shelf

B8DST93300

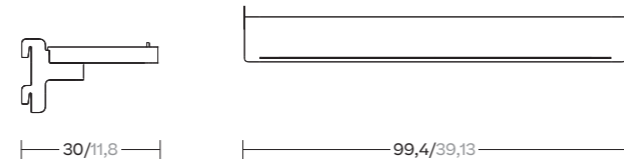

Magnetic white board

B8BRD04900

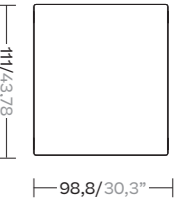

Hanger/Picture support

B897700F00



Hangers for magnetic bar

B897700FMS

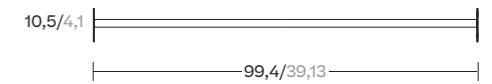

Finishes

Finishes

Contemporary & elegant finishes
for endless combinations.

The wide selections of materials include fabrics, metals, woods, stones and ceramics. All of these worlds form the basis of the library. We invite the professional to explore and combine colors, textures and materials to create exclusive codes for each project.

Fabrics

A - Terrain Elements



L: Laminate
T: No laminate (only for umbrellas)



Fabrics

B - Modernist



Oscar 62J Mies 64J Lina 61J Neutra 60J Eileen 59J



Doshi 63J Kahn 68J Eulie 53J Afra 54J 67J Schindler



Scarpa 51J Correa 52J Perriand 55J Anni 65J Lihotsky 56J Ray 66J

C - Tonale Boucle laminate

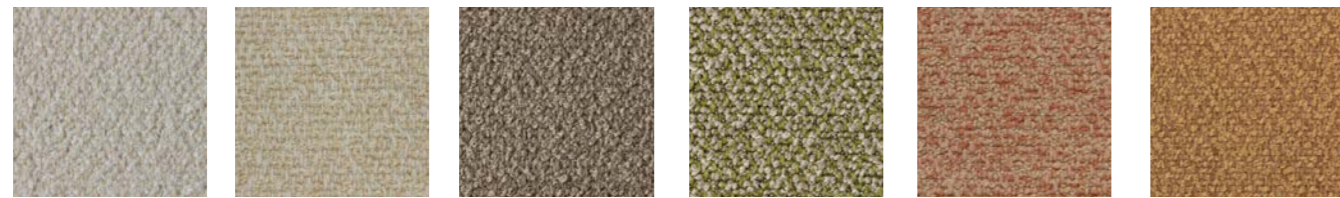

White Poppy 81L Sesame 82L Anise 83L Dill 84L Allspice Jamaica 85L Bird's foot 86L

C - Rockress

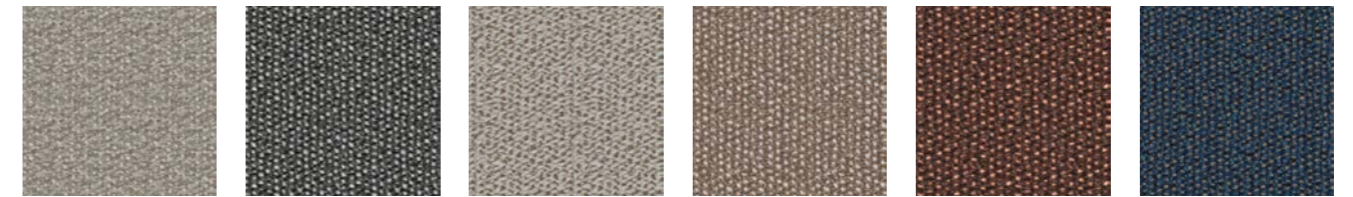

Silver Falls D1L Black Velvet D2L Summer Snow D3L Cherry Caramel D4L Red Robin D5L Blue Thyme D6L

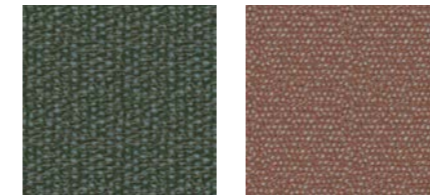

Silver Falls D7L Arabis D8L

C - Kimolos

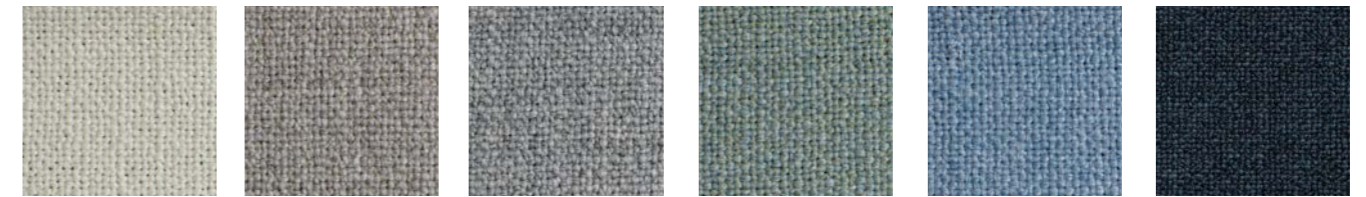

Lumen 51K Terra 52K Eter 57K Natura 54K Aqua 55K Profondo 56K



Stripes Sand 63K Stripes Terra 60K Stripes Aqua 61K Stripes Navis 12K

Tilos Piping

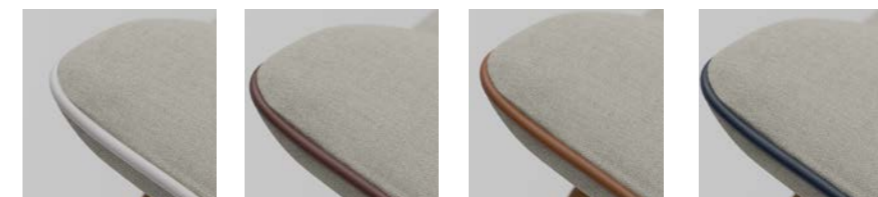

Ecrú 001 Camel 002 Pecan 003 Blue nit 004

Paints

Terrain Paint

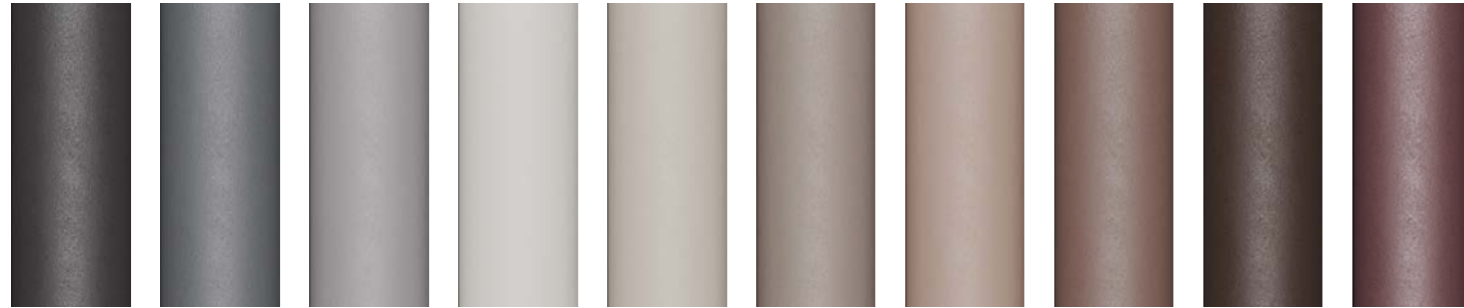

Slate Stone 01C Misty Smoke 02C Ash 03C Bone 04C Tuff 05C Wet Stone 06C Sand Dune 07C Dry Clay 08C Arabica 09C Sepia 19C

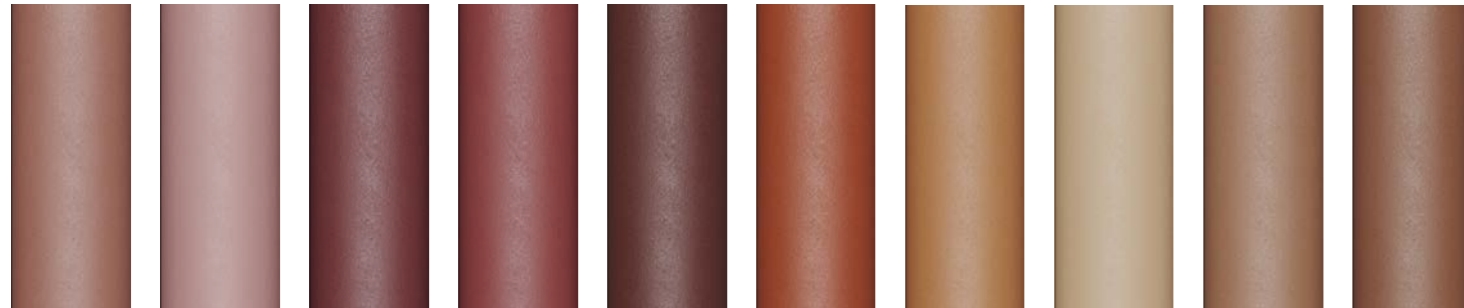

Rose Canyon 16C Blossom 20C Ruby Dust 18C Sunset Glow 17C Terrarosa 15C Terracota 14C Amber 13C Ginger Root 12C Desert Storm 11C African Savannah 10C

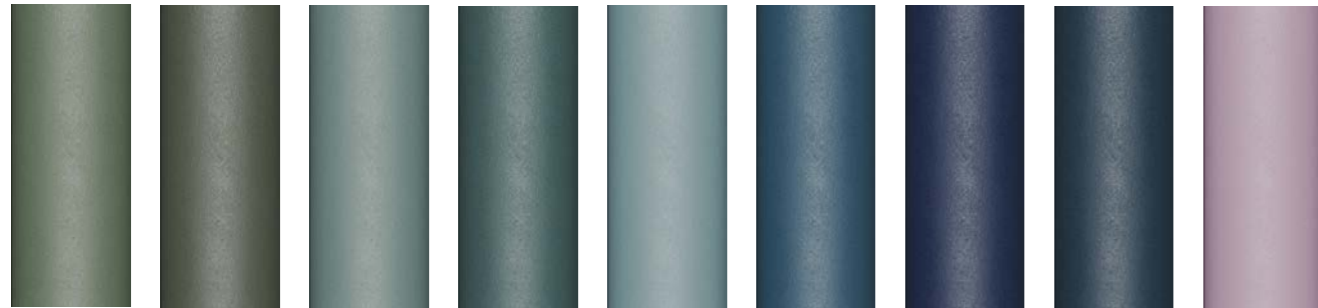

Spring Meadow 28C Kombu 29C Forest Stream 27C Sea Moss 26C Glacier Ice 25C Polar Sky 24C Nightfall 23C Indigo 22C Wild Lupin 21C



Galena 33C Bronze 30C Corten 31C Manganese 32C

Terrain Lustre



Bone lustre CH1 Tuff lustre 05B African Savannah lustre 10B Terre Sienne lustre CH3 Spring Meadow lustre 28B Vert lustre CH4 Glacier Ice lustre 25B Indigo lustre 22B Noir d'Ivoire lustre CH2

Glaze Agate



Camelian Agate Indian Agate Moss Agate Sapphire Agate Botswana Agate

Waranty terms

For domestic use, all products, except for cushions, covers and fabrics (including textilines), are guaranteed for a period of five years against any manufacturing defect that affects their suitability for use. This applies to normal conditions of use and maintenance. This guarantee does not apply to faults or imperfections resulting from the passage of time or normal wear and tear. Circumstances not covered by this guarantee include, but are not limited to, the fading or change in shade of colours, changes in wood texture, scratches resulting from use, etc. For non-domestic use, by the hotel and catering industry and collectives for example, all products, except cushions, covers and fabrics, are guaranteed for a period of two years. This guarantee is subject to the same conditions as outlined above.

Technical specifications

Committed to innovation and quality, Ketta's collections are manufactured to the strictest quality standards, from the selection of the materials, to the quality and safety testing of the furniture.

We would love to hear from you.

Head office

Kettal Barcelona
Aragón, 316
08009 Barcelona, Spain
T. (34) 93 487 90 90
F. (34) 93 487 90 66

Showrooms

Miami Showroom
147 Miracle Mile
Coral Gables,
Florida 33134, USA
t. (1) 786 552 90 22
miami.store@kettal.es

New York
The D&D Annex:
222 East 59th Street
Suite 222-333
New York, NY 10022, USA
t. (1) 917-992-9419
newyork.showroom@kettal.com

Chicago
The Mart.
222 Merchandise Mart Plaza,
Suite 377
Chicago, IL 60654 USA.
T. 312.244.0527
chicago.showroom@kettal.es

London Showroom
15-16 Dufferin St,
London EC1Y 8PD, Reino Unido
t. +44 7498 846 352

Paris Showroom
80, Blvd Malesherbes
75008 Paris, France
t. (33) 1 43 59 51 40
boutique.paris@kettal.es

Melbourne Showroom
510 Church Street Melbourne
Richmond VIC 3121, Australia
t. (03) 9957 8799

Kettal Barcelona
Aragón, 316
08009 Barcelona, Spain
T. (34) 93 488 10 80
tienda.bcn@kettal.es

Marbella Showroom
Crtra. de Cádiz, Km.179
(entre el Marbella Club
y el Guadalpin)
29600 Marbella, Spain
t. (34) 95 277 89 89
tienda.marbella@kettal.es

New opening

Milano showroom
Via Broletto, 44/46, 20121
Milano MI, Italia

Press Kit



To download the Press Releases and
high res images please register in the
Press Area here