

**FLEXFORM**

FLEXFORM | MADE IN ITALY

NEW  
ENTRIES  
2018

**FLEXFORM**

**FLEXFORM | MADE IN ITALY**

Sottile filo conduttore della nuova collezione Flexform e comune denominatore dei nuovi divani, delle poltrone e degli accessori è il concetto di “Good Design”.

Il “Good Design” riassume in sé una pluralità di caratteristiche intrinseche quali l’innovazione, la funzionalità e naturalmente l’estetica che, tuttavia, non è mai fine a sé stessa. Il “Good Design” è profondamente onesto: è progettato per durare nel tempo ed è user friendly perché mira a migliorare la quotidianità.

Il “Good Design” non è intrusivo perché emana quell’eleganza misurata ed effortless che gli consente di inserirsi armoniosamente in qualsiasi ambiente.

La nuova collezione Flexform segna un ulteriore passo in avanti nel percorso ben delineato della coerenza progettuale che da sempre contraddistingue l’azienda.

The concept of Good Design is the subtle thread that runs through the new Flexform collection and common denominator of the new sofas, armchairs and accessories.

Good Design embodies myriad inherent qualities like innovation, functionality and, of course, beauty that, however, is never an end unto itself. Good Design wears honesty on its sleeve – made to last and user-friendly, because it is meant to improve daily life.

Good Design is never intrusive because it radiates an understated, effortless elegance that makes it at home in any setting.

The new Flexform collection is another milestone on the tactical journey of design consistency that sets the company apart.

# Index

## SOFAS | SECTIONAL SOFAS | OTTOMANS

CAMPIELLO | 4



NEWBRIDGE | 16



ESTE | 30



## ARMCHAIRS | OTTOMANS

HERA | 40



HERA | 43



HERA | 44



HERA | 45



ALISON | 36



SVEVA | 56



LEDA | 53



LEDA | 50



## TABLES

GUSTAV | 66



SPELLO | 72



ZEFIRO | 80



## COFFEE AND SIDE TABLES

ASCANIO | 62



GUSTAV | 70



SVEVA | 61



## DINING CHAIRS AND ARMCHAIRS | BAR STOOLS

HERA | 46  
HIGH BACK



HERA | 46  
WITHOUT ARMRESTS



HERA | 47  
HIGH BACK



HERA | 47  
WITHOUT ARMRESTS



HERA | 48  
LOW BACK



HERA | 48  
WITH ARMRESTS



HERA | 49  
LOW BACK



HERA | 49  
WITH ARMRESTS



LEDA | 55



LEDA | 54



ISABEL | 84



## CABINETS

TAYLOR | 76



## BEDS

ADDA | 32



ESTE | 26



# Campiello

Antonio Citterio Design

Divani | Divani componibili | Pouf

**Sofas | Sectional Sofas | Ottomans**

Campiello è l'ultimo nato nella grande famiglia dei divani progettati da Antonio Citterio per Flexform e che, come già i suoi predecessori, coniuga alle linee pulite ed essenziali, una promessa di calda accoglienza e grande morbidezza.

I cuscini di seduta hanno un inserto centrale realizzato in materiale indeformabile avvolto da un generoso e soffice strato di piuma d'oca.

I cuscini schienale sono anch'essi in piuma per amplificare la sensazione di avvolgente morbidezza e sono disponibili nelle versioni con o senza rullo per ottenere risultati differenti sia sul piano estetico che ergonomico. Il cuscino con rullo offre un maggiore supporto alla schiena ed al collo.

Il divano poggia su un'elegante base in alluminio pressofuso verniciato nei colori grigio e bronzo, oppure satinato, cromato, brunito, cromo nero e champagne.

La personalità trasversale del divano Campiello gli consente di inserirsi armoniosamente in qualunque ambiente, dal classico al contemporaneo, e di vestire con eguale disinvoltura tutti i tessuti e le pelli della collezione Flexform.

Campiello is the most recent addition to the exceptional family of sofas designed by Antonio Citterio for Flexform. Like its predecessors, it combines clean, uncluttered lines with a promise of inviting warmth and amazing softness.

The seat cushions are made with a core insert in crushproof material wrapped in a generous, soft layer of goose down.

The seat back cushions are also filled with goose down to magnify the feeling of enveloping softness and are available in versions with or without roll cushion to achieve different aesthetic and ergonomic effects. The version with roll cushion provides greater back and neck support.

The sofa sits on an elegant cast aluminum base painted gray or bronze, or with satin, chromed, burnished, black chrome or champagne finish.

The Campiello sofa's versatile personality allows it to fit confidently in any setting, from classic to contemporary, and is equally at ease upholstered in any of the fabrics and leathers in the Flexform collection.



CATEGORY SOFAS | SECTIONAL SOFAS | OTTOMANS  
PRODUCT CAMPIELLO  
DESIGN ANTONIO CITTERIO

6



7



CATEGORY SOFAS | SECTIONAL SOFAS | OTTOMANS  
PRODUCT CAMPIELLO  
DESIGN ANTONIO CITTERIO



8

9



CATEGORY SOFAS | SECTIONAL SOFAS | OTTOMANS  
PRODUCT CAMPIELLO  
DESIGN ANTONIO CITTERIO

10



11



CATEGORY SOFAS | SECTIONAL SOFAS | OTTOMANS  
PRODUCT CAMPIELLO  
DESIGN ANTONIO CITTERIO



12

13





**JIFF**  
TAVOLINO  
SIDE TABLE

**ZEFIRO**  
TAVOLINO  
SIDE TABLE

**FLY**  
TAVOLINO  
COFFEE TABLE

**OLIVER**  
TAVOLINO  
SIDE TABLE

**CRONO**  
POLTRONA  
ARMCHAIR

**FEEL GOOD**  
POLTRONA  
ARMCHAIR

**FLY**  
TAVOLINO  
COFFEE TABLE

**BANGKOK**  
POUF  
OTTOMAN

**CAMPIELLO**  
DIVANO  
SOFA



**GUSCIO**  
POLTRONA  
ARMCHAIR

**GIANO**  
SGABELLO  
STOOL

**GIANO**  
TAVOLINO  
COFFEE TABLE

**CAMPIELLO**  
DIVANO COMPONIBILE  
SECTIONAL SOFA

**BRIG**  
CONSOLLE  
CONSOLE

**FLY**  
TAVOLINO  
SIDE TABLE

**OLIVER**  
TAVOLINO  
SIDE TABLE

**FLY**  
TAVOLINO  
SIDE TABLE

**FLY**  
TAVOLINO  
COFFEE TABLE

**PIUMA**  
CONTENITORE  
STORAGE UNIT

**THOMAS**  
POLTRONA  
ARMCHAIR

**FEEL GOOD**  
POUF  
OTTOMAN

**CAMPIELLO**  
DIVANO 277X116  
FINITURA  
BASE METALLO  
BRUNITO  
**CAMPIELLO**  
CUSCINO 80x60  
CON RULLO  
**CAMPIELLO**  
CUSCINO 100x60  
CON RULLO  
**CAMPIELLO**  
CUSCINO 60x60  
RIVESTIMENTO  
TIVOLI 1032  
**FEEL GOOD**  
POLTRONA GIREVOLE  
FINITURA  
BASE METALLO  
BRUNITO  
RIVESTIMENTO  
PELLE 623  
**CRONO**  
POLTRONA  
FINITURA  
NOCE CANALETTO,  
CUOIO NATURALE  
RIVESTIMENTO

ELEGANCE 943  
**CRONO**  
COPPIA CUSCINI 50X50  
RIVESTIMENTO  
ELEGANCE 943  
**BANGKOK**  
POUF 60X50  
FINITURA  
BASE METALLO  
BRUNITO,  
CUOIO 6004  
**FLY**  
TAVOLINO  
170x100 H35  
FINITURA  
BASE METALLO  
BRUNITO,  
TOP CALACATTA  
ORO OPACO  
**FLY**  
TAVOLINO 80X80H47  
FINITURA  
BASE METALLO  
BRUNITO, TOP NOCE  
CANALETTO  
**JIFF**  
TAVOLINO H46  
FINITURA

NOCE CANALETTO  
**OLIVER**  
TAVOLINO  
FINITURA  
NOCE CANALETTO  
**ZEFIRO**  
TAVOLINO Ø50 H40  
WITH ROLL  
FINITURA  
BASE METALLO  
BRUNITO,  
TOP CALACATTA  
ORO OPACO  
**ZEFIRO**  
TAVOLINO Ø50 H40  
FINITURA  
BASE METALLO  
BRUNITO, TOP IN  
NOCE CANALETTO

**CAMPIELLO**  
SOFA 277X116  
FINISH  
BURNISHED METAL  
BASE  
**CAMPIELLO**  
CUSHION 80x60  
WITH ROLL  
**CAMPIELLO**  
CUSHION 100x60  
WITH ROLL  
**CAMPIELLO**  
CUSHION 60x60  
UPHOLSTERY  
TIVOLI 1032  
**FEEL GOOD**  
SWIVEL ARMCHAIR  
FINISH  
BURNISHED METAL  
BASE  
UPHOLSTERY  
LEATHER 623  
**CRONO**  
ARMCHAIR  
FINISHES  
CANALETTO WALNUT,  
NATURAL HIDE  
LEATHER

UPHOLSTERY  
ELEGANCE 943  
**CRONO**  
PAIR OF CUSHIONS  
50X50  
UPHOLSTERY  
ELEGANCE 943  
**BANGKOK**  
OTTOMAN 60X50  
FINISHES  
BURNISHED METAL  
BASE, HIDE  
LEATHER 6004  
**FLY**  
COFFEE TABLE  
170x100 H35  
FINISHES  
BURNISHED  
METAL BASE,  
TOP CALACATTA  
ORO MATT  
**FLY**  
COFFEE TABLE  
80X80 H47  
FINISHES  
BURNISHED METAL  
BASE, TOP  
CANALETTO WALNUT

**JIFF**  
SIDE TABLE H46  
FINISH  
CANALETTO WALNUT  
**OLIVER**  
SIDE TABLE  
FINISH  
CANALETTO WALNUT  
**ZEFIRO**  
SIDE TABLE Ø50 H40  
FINISHES  
BURNISHED METAL  
BASE, TOP  
CALACATTA ORO MATT  
**ZEFIRO**  
SIDE TABLE Ø50 H40  
FINISHES  
BURNISHED METAL  
BASE, TOP  
CANALETTO WALNUT

**CAMPIELLO**  
FIANCO 258x116  
**CAMPIELLO**  
FIANCO TERMINALE  
218x116  
FINITURA  
BASE METALLO BRUNITO  
**CAMPIELLO**  
CUSCINO 80x60  
C/RULLO  
**CAMPIELLO**  
CUSCINO 60x60  
C/RULLO  
**CAMPIELLO**  
CUSCINO 60x60  
RIVESTIMENTO  
TIVOLI 1032  
**GUSCIO**  
POLTRONA  
FINITURA  
BASE METALLO BRUNITO  
RIVESTIMENTO  
PELLE 629  
**OLIVER**  
TAVOLINO  
FINITURA  
NOCE CANALETTO  
**GIANO**

SGABELLO  
FINITURA  
NOCE CANALETTO,  
CUOIO NATURALE  
**FLY**  
TAVOLINO Ø40  
FINITURA  
BASE METALLO BRUNITO  
N.2 TOP IN  
CALACATTA  
ORO OPACO  
N.1 TOP NOCE  
CANALETTO  
**FLY**  
TAVOLINO Ø60  
FINITURA  
BASE METALLO  
BRUNITO,  
TOP IN CALACATTA  
ORO OPACO  
**FLY**  
TAVOLINO 90x50  
FINITURA  
BASE METALLO BRUNITO  
TOP NOCE CANALETTO  
**GIANO**  
TAVOLINO 170x100  
FINITURA

BASE NOCE CANALETTO,  
TOP CALACATTA  
ORO OPACO  
**PIUMA**  
CONTENITORE  
100X48 H30  
FINITURA  
BASE METALLO  
BRUNITO,  
NOCE CANALETTO  
**THOMAS**  
POLTRONA  
FINITURA  
NOCE CANALETTO  
RIVESTIMENTO  
ELEGANCE 983  
**BRIG**  
CONSOLLE 180x45  
FINITURA  
NOCE CANALETTO,  
TOP IN CALACATTA ORO  
OPACO  
**FEEL GOOD**  
POUF  
FINITURA  
BASE METALLO BRUNITO  
RIVESTIMENTO  
EMPIRE 895

**CAMPIELLO**  
END UNIT 258X116  
**CAMPIELLO**  
LONG CORNER 218X116  
FINISH  
BURNISHED METAL BASE  
**CAMPIELLO**  
CUSHION 80x60  
W/RULLO  
**CAMPIELLO**  
CUSHION 60x60  
W/RULLO  
**CAMPIELLO**  
CUSHION 60x60  
UPHOLSTERY  
TIVOLI 1032  
**GUSCIO**  
ARMCHAIR  
FINISH  
BURNISHED METAL BASE  
UPHOLSTERY  
PELLE 629  
**OLIVER**  
SIDE TABLE  
FINISH  
CANALETTO WALNUT  
**GIANO**  
STOOL

FINISHES  
CANALETTO WALNUT,  
NATURAL HIDE LEATHER  
**FLY**  
SIDE TABLE Ø40  
FINISHES  
BURNISHED METAL BASE  
N.2 TOP CALACATTA  
ORO MATT  
N.1 TOP CANALETTO  
WALNUT  
**FLY**  
SIDE TABLE Ø60  
FINISHES  
BURNISHED METAL  
BASE, TOP CALACATTA  
ORO MATT  
**FLY**  
SIDE TABLE 90x50  
FINISHES  
BURNISHED METAL  
BASE,  
TOP CANALETTO  
WALNUT  
**GIANO**  
COFFEE TABLE 170x100  
FINISHES  
CANALETTO WALNUT

TOP CALACATTA  
ORO MATT  
**PIUMA**  
STORAGE UNIT  
100X48 H30  
FINISHES  
BURNISHED METAL  
BASE  
CANALETTO WALNUT  
**THOMAS**  
ARMCHAIR  
FINISH  
CANALETTO WALNUT  
UPHOLSTERY  
ELEGANCE 983  
**BRIG**  
CONSOLLE 180x45  
FINISHES  
CANALETTO WALNUT,  
TOP CALACATTA  
ORO MATT  
**FEEL GOOD**  
OTTOMAN  
FINISH  
BURNISHED METAL  
BASE  
UPHOLSTERY  
EMPIRE 895

# Newbridge

Carlo Colombo Design

Divani | Divani componibili | Pouf

**Sofas | Sectional Sofas | Ottomans**

Il divano Newbridge presenta proporzioni equilibrate unite a forme morbide e ad imbottiture generose, che lo rendono particolarmente accogliente.

Base, sedute, schienali e braccioli presentano i medesimi spessori e sono caratterizzati da imbottiture extra-soft in un innovativo materiale elastico dalle elevate prestazioni: indeformabile, flessibile ed eccezionalmente morbido. Queste caratteristiche garantiscono ottime performance in tema di confort, durevolezza e traspirabilità.

I cuscini di seduta sono disponibili anche nella versione in piuma d'oca.

L'avvolgente effetto "cocoon" è amplificato dal particolare del bracciolo reclinabile che può assumere diverse inclinazioni per consentire di ottenere la posizione desiderata.

La parte esterna del bracciolo è contraddistinta da un elegante profilo mentre una ricercata barra in metallo personalizza il bracciolo in prossimità della piega del rivestimento, che può essere realizzato sia in tessuto che in pelle.

Il divano si mantiene sollevato da terra a mezzo di ricercati piedini in metallo pressofuso realizzati su disegno.

Balanced proportions combined with soft contours and generous padding make the Newbridge sofa warm and inviting.

Bases, seats, seat backs and armrests all have the same thickness and feature extra-soft padding in an innovative, high-performance elastic material, making it crushproof, supple and uncommonly soft. These features ensure superior performance in terms of comfort, durability and breathability. The seat cushions also come with optional goose down filling.

The reclinable armrest heightens the enveloping "cocoon" effect and can be adjusted to achieve the desired position.

Elegant piping outlines the armrest, while an exquisite metal bar near the upholstery fold customizes the look; upholstery available in fabric or leather.

The sofa sits on elegant, custom-designed cast metal feet.



CATEGORY SOFAS | SECTIONAL SOFAS | OTTOMANS  
PRODUCT NEWBRIDGE  
DESIGN CARLO COLOMBO

18



19



CATEGORY SOFAS | SECTIONAL SOFAS | OTTOMANS  
PRODUCT NEWBRIDGE  
DESIGN CARLO COLOMBO



20

21



CATEGORY SOFAS | SECTIONAL SOFAS | OTTOMANS  
PRODUCT NEWBRIDGE  
DESIGN CARLO COLOMBO

22



23





**ISABEL**  
POLTRONA  
ARMCHAIR

**OLIVER**  
TAVOLINO  
SIDE TABLE

**JIFF**  
CONSOLLE  
CONSOLE

**GUSTAV**  
TAVOLINO  
SIDE TABLE

**JENNY**  
POLTRONA  
ARMCHAIR

**FILICUDI**  
POUF  
OTTOMAN

**GUSTAV**  
TAVOLINO  
COFFEE TABLE

**NEWBRIDGE**  
DIVANO  
SOFA

**JIFF**  
TAVOLINO  
SIDE TABLE

**NEWBRIDGE**  
BRACCIOLO 103  
RECLINABILE  
FINITURA  
METALLO BRUNITO  
**NEWBRIDGE**  
ELEMENTO 100X108  
**NEWBRIDGE**  
CUSCINO 45X45  
**NEWBRIDGE**  
CUSCINO 60X50  
RIVESTIMENTO  
TOPAZIO 992  
**ISABEL**  
POLTRONA  
RIVESTIMENTO  
CUOIO 5013  
**OLIVER**  
TAVOLINO  
FINITURA  
FRASSINO TINTO  
MARRONE  
**FILICUDI**  
POUF 65X45  
FINITURA  
BASE METALLO  
BRUNITO,  
CUOIO 5013

**GUSTAV**  
TAVOLINO Ø125  
**GUSTAV**  
TAVOLINO Ø63  
**GUSTAV**  
TAVOLINO Ø48  
FINITURA  
FRASSINO TINTO  
MARRONE,  
TOP CALACATTA  
ORO OPACO  
**JIFF**  
CONSOLLE  
FINITURA  
FRASSINO TINTO  
MARRONE  
**JENNY**  
POLTRONA  
FINITURA  
FRASSINO TINTO  
MARRONE  
RIVESTIMENTO  
ELEGANCE 955  
**JIFF**  
TAVOLINO H46  
FINITURA  
FRASSINO TINTO  
MARRONE

**NEWBRIDGE**  
RECLINABILE  
ARMREST 103  
FINISH  
BURNISHED METAL  
**NEWBRIDGE**  
UNIT100X108  
**NEWBRIDGE**  
CUSHION 45X45  
**NEWBRIDGE**  
CUSHION 60X50  
UPHOLSTERY  
TOPAZIO 992  
**ISABEL**  
ARMCHAIR  
UPHOLSTERY  
HIDE LEATHER 5013  
**OLIVER**  
SIDE TABLE  
FINISH  
ASH STAINED  
BROWN  
**FILICUDI**  
OTTOMAN 65X45  
FINISHES  
BURNISHED  
METAL BASE,  
HIDE LEATHER 5013

**GUSTAV**  
COFFEE TABLE Ø125  
**GUSTAV**  
SIDE TABLE Ø63  
**GUSTAV**  
SIDE TABLE Ø48  
FINISHES  
ASH STAINED  
BROWN,  
TOP CALACATTA  
ORO MATT  
**JIFF**  
CONSOLLE  
FINISH  
ASH STAINED  
BROWN  
**JENNY**  
ARMCHAIR  
FINISH  
ASH STAINED  
BROWN  
UPHOLSTERY  
ELEGANCE 955  
**JIFF**  
SIDE TABLE H46  
FINISH  
ASH STAINED  
BROWN

**NEWBRIDGE**  
BRACCIOLO 103  
RECLINABILE  
**NEWBRIDGE**  
BRACCIOLO 103  
**NEWBRIDGE**  
BRACCIOLO 88  
RECLINABILE  
FINITURA  
METALLO BRUNITO  
RIVESTIMENTO  
TOPAZIO 992  
**NEWBRIDGE**  
ELEMENTO 100X108  
**NEWBRIDGE**  
ELEMENTO 85X93  
**NEWBRIDGE**  
CUSCINO 45X45  
**NEWBRIDGE**  
CUSCINO 60X50  
RIVESTIMENTO  
TOPAZIO 992  
**ISABEL**  
POLTRONA  
RIVESTIMENTO  
CUOIO 5013  
**BANGKOK**  
POUF 60X50

FINITURA  
BASE METALLO  
BRUNITO, CUOIO 6004  
**GUSTAV**  
TAVOLINO Ø125  
**GUSTAV**  
TAVOLINO Ø63  
**GUSTAV**  
TAVOLINO Ø48  
FINITURA  
FRASSINO  
TINTO MARRONE,  
TOP CALACATTA  
ORO OPACO  
**JIFF**  
CONSOLLE  
FINITURA  
FRASSINO TINTO  
MARRONE  
**JENNY**  
POLTRONA  
FINITURA  
FRASSINO TINTO  
MARRONE  
RIVESTIMENTO  
ELEGANCE 955  
**JIFF**  
TAVOLINO H46

FINITURA  
FRASSINO TINTO  
MARRONE

**NEWBRIDGE**  
RECLINABILE  
ARMREST 103  
**NEWBRIDGE**  
ARMREST 103  
**NEWBRIDGE**  
RECLINABILE  
ARMREST 88  
FINISH  
BURNISHED METAL  
UPHOLSTERY  
TOPAZIO 992  
**NEWBRIDGE**  
UNIT 100X108  
**NEWBRIDGE**  
UNIT 85X93  
**NEWBRIDGE**  
CUSCINO 45X45  
**NEWBRIDGE**  
CUSCINO 60X50  
UPHOLSTERY  
TOPAZIO 992  
**ISABEL**  
ARMCHAIR  
UPHOLSTERY  
HIDE LEATHER 5013  
**BANGKOK**  
OTTOMAN 60X50

FINISHES  
BURNISHED  
METAL BASE,  
HIDE LEATHER 6004  
**GUSTAV**  
COFFEE TABLE Ø125  
**GUSTAV**  
SIDE TABLE Ø63  
**GUSTAV**  
SIDE TABLE Ø48  
FINISHES  
ASH STAINED  
BROWN, TOP  
CALACATTA ORO MATT  
**JIFF**  
CONSOLLE  
FINISH  
ASH STAINED  
BROWN  
**JENNY**  
ARMCHAIR  
FINISH  
ASH STAINED  
BROWN  
UPHOLSTERY  
ELEGANCE 955  
**JIFF**  
SIDE TABLE H46

FINISH  
ASH STAINED  
BROWN

**JIFF**  
TAVOLINO  
SIDE TABLE

**ISABEL**  
POLTRONA  
ARMCHAIR

**GUSTAV**  
TAVOLINO  
SIDE TABLE

**GUSTAV**  
TAVOLINO  
COFFEE TABLE

**BANGKOK**  
POUF  
OTTOMAN

**NEWBRIDGE**  
DIVANO COMPONIBILE  
SECTIONAL SOFA

**JIFF**  
CONSOLLE  
CONSOLE

**JENNY**  
POLTRONA  
ARMCHAIR



# Este

Antonio Citterio Design

Letti • Divani | Divani componibili | Pouf

**Beds • Sofas | Sectional Sofas | Ottomans**

Il letto Este si distingue per la sua originale struttura: una sorta di leggero guscio in metallo completamente rivestito in cuoio che, come una corolla, racchiude i morbidi cuscini della testata ed il materasso. Al disegno rigoroso ed essenziale, si accompagna la scelta di un materiale nobile come il cuoio che conferisce fascino ed eleganza al progetto. La sofisticata confezione è ben evidente nella lavorazione degli angoli, delle cuciture e degli spessori del cuoio.

Il letto si mantiene sollevato da terra tramite una raffinata base in metallo pressofuso disponibile nelle finiture satinato, cromato, brunito, cromo nero e champagne.

La grande versatilità del letto Este è amplificata dalla possibilità di realizzare diverse combinazioni tra la base in cuoio, disponibile in nove colori, e la testata imbottita che può essere rivestita in tutti i tessuti e le pelli della collezione.

La famiglia Este vede inoltre l'inserimento di una versatile panca imbottita, caratterizzata dalla medesima base in metallo.

Thanks to its singular shape, the Este bed is immediately eye-catching. A kind of lightweight metal shell, completely upholstered in saddle hide, envelops the soft headboard and mattress cushions like a flower corolla. The sleek, uncluttered design goes hand-in-hand with a splendid material like saddle hide that lends allure and elegance to the whole. The expert tailoring is apparent in the workmanship of the corners, the stitching and the thicknesses of the saddle hide. The bed is raised off the floor on a cast metal base available in satin, chromed, burnished, black chrome or champagne finish.

The incredible versatility of the Este bed is expanded by the possibility to create various combinations between the saddle hide base, available in nine colors, and the upholstered headboard that can be covered in all the fabrics and leathers in the collection.

The Este family now also includes a versatile ottoman, featuring the same metal base.



CATEGORY BEDS  
PRODUCT ESTE  
DESIGN ANTONIO CITTERIO

28

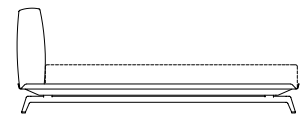

29



CATEGORY SOFAS | SECTIONAL SOFAS | OTTOMANS  
PRODUCT ESTE  
DESIGN ANTONIO CITTERIO

30



31

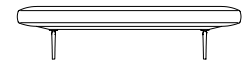

# Adda

Antonio Citterio Design

Letti  
**Beds**

L'estetica asciutta e contemporanea che caratterizza il divano Adda – presentato al Salone del Mobile nell'aprile 2017 – si declina ora nell'omonimo letto.

Ai volumi generosi della testata imbottita si contrappone una slanciata base in metallo, rivestita in tessuto o pelle, con eleganti piedi in metallo pressofuso disponibili nelle finiture satinato, cromato, brunito, cromo nero e champagne.

La morbida testata è costituita da due soffici cuscini imbottiti in piuma d'oca, contraddistinti da un profilo che ne sottolinea le forme e da originali cuciture longitudinali che producono un leggero avvallamento che sottolinea il carattere del progetto.

La linea essenziale del letto Adda gli consente di vestire con eguale disinvoltura tutti i tessuti e le pelli della collezione Flexform e di inserirsi armoniosamente in qualsiasi contesto abitativo.

The modern, essential aesthetic that sets the Adda sofa apart - launched at the Salone del Mobile in April, 2017 - has now been extended to its namesake bed.

The generous proportions of the upholstered headboard contrast smartly with the sleek metal base, upholstered in fabric or leather, with refined cast metal feet that come in satin, chromed, burnished, black chrome or champagne finish.

The soft headboard is composed of two goose down filled cushions. Elegant piping emphasizes their shape and unique horizontal stitching creates a slight indentation, adding to the distinctive personality of the design.

The uncluttered lines of the Adda bed ensure it looks equally fashionable in any of the fabrics or leathers from the Flexform collection and are its passport to fitting seamlessly in any style of home.



CATEGORY BEDS  
PRODUCT ADDA  
DESIGN ANTONIO CITTERIO

34



35

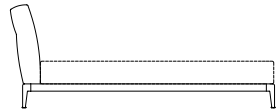

# Alison

Carlo Colombo Design

Poltrone | Pouf

**Armchairs | Ottomans**

La poltrona Alison fa tesoro della grande tradizione del design scandinavo, reinterpretato in una chiave assolutamente contemporanea.

La flessuosa struttura è in legno massello, la seduta è generosamente imbottita mentre lo schienale in cuoio offre un supporto particolarmente confortevole.

Innumerevoli quanto originali le combinazioni materico-cromatiche che si possono ottenere associando la struttura che può essere realizzata in massello di noce canaletto o frassino tinto in numerose nuances, allo schienale in cuoio disponibile in nove colori e alla seduta imbottita che può essere rivestita in tutti i tessuti e le pelli dell'esclusiva collezione Flexform.

Grazie alle proporzioni compatte e alla sua allure al di là del tempo e delle mode, la poltrona Alison si mostra perfettamente a suo agio in qualsiasi ambiente.

The Alison armchair draws upon Scandinavian design tradition, reinterpreting it through a completely contemporary lens.

The sinuously curved structure is made of solid wood and the seat is generously padded. The saddle hide seat back provides optimal support.

The combinations of materials and colors can be as endless as they are unique by marrying the structure in solid Canaletto walnut or solid ash - stained in many shades - with the seat back in saddle hide, available in nine colors, and the padded seat that can be upholstered in any of the exclusive fabrics and leathers from the Flexform collection.

Thanks to its scaled-down proportions and timeless charm, the Alison armchair is supremely at home in any setting.



CATEGORY ARMCHAIRS | OTTOMANS  
PRODUCT ALISON  
DESIGN CARLO COLOMBO

38



39



# Hera

Antonio Citterio Design

Poltrone | Pouf • Poltroncine | Sedie

**Armchairs | Ottomans • Dining Chairs | Dining Armchairs**

Hera è una famiglia di poltrone e sedie, che esprime una felice sintesi di ergonomia ed eleganza, espressamente progettata sia per un utilizzo in ambito domestico che per contesti hospitality, quali aree lounge, sale d'attesa, ristoranti.

Presenta una costruzione leggera grazie alla scocca realizzata in uno speciale materiale polimerico, che garantisce un elevato livello di confort.

Le poltrone e le sedie Hera sono completamente sfoderabili e sono proposte nella duplice versione con affusolate gambe in alluminio pressofuso nelle finiture satinato, cromato, brunito, cromato nero e champagne oppure in massello di noce canaletto o di frassino in una varietà di tinte.

Hera is a family of armchairs and chairs that brilliantly combines ergonomics and elegance, specifically designed for use both in domestic and hospitality settings like lounges, waiting rooms and restaurants.

Thanks to a shell made of a special polymer, its construction is graceful and ensures premium comfort.

The Hera armchairs and chairs have completely removable upholstery and are available in two versions: with tapered, cast aluminum legs with satin, chromed, burnished, black chromed or champagne finish; as well as in solid Canaletto walnut or solid ash stained in a choice of shades.



CATEGORY ARMCHAIRS | OTTOMANS  
PRODUCT HERA  
DESIGN ANTONIO CITTERIO

42



43



CATEGORY ARMCHAIRS | OTTOMANS  
PRODUCT HERA  
DESIGN ANTONIO CITTERIO

44



45



CATEGORY DINING CHAIRS | DINING ARMCHAIRS  
PRODUCT HERA  
DESIGN ANTONIO CITTERIO

46



47



CATEGORY DINING CHAIRS | DINING ARMCHAIRS  
PRODUCT HERA  
DESIGN ANTONIO CITTERIO

48



49



# Leda

Antonio Citterio Design

Poltrone | Pouf • Poltroncine | Sedie

**Armchairs | Ottomans • Dining Chairs | Dining Armchairs**

Una famiglia di sedute in perfetto equilibrio tra tradizione e modernità, che rappresenta in modo esemplare come la produzione seriale dell'azienda conservi un legame profondo con l'artigianalità. Motivo caratterizzante è la base in legno che richiama la tradizione del design scandinavo e coniuga eleganza e razionalità. Su di essa si innesta il morbido guscio imbottito della seduta. La scocca dalla forma avvolgente è realizzata in uno speciale materiale polimerico dalle ottime proprietà strutturali, che conferisce morbidezza per garantire il massimo confort.

La famiglia Leda comprende due poltrone, una con schienale basso e una con schienale alto ed inoltre una sedia ed una poltroncina.

Tutti gli elementi della famiglia Leda sono completamente sfoderabili.

Exemplary of how the company, in an age of standardized production, maintains its deep ties with artisan craftsmanship is this family of chairs neatly balanced between tradition and modernity.

The wood base is distinguished by a motif that echoes the tradition of Scandinavian design with a blend of elegance and rationality. Grafted into the base is the soft, padded shell of the seat. This enveloping shell is made of a special polymer that offers superior structural properties and the kind of softness that ensures the utmost in comfort.

The Leda family includes two armchairs – with low seat back or high seat back – along with a chair and a small armchair.

The upholstery is removable on all of the pieces in the Leda family.



CATEGORY ARMCHAIRS | OTTOMANS  
PRODUCT LEDA  
DESIGN ANTONIO CITTERIO

52



53



CATEGORY DINING CHAIRS | DINING ARMCHAIRS  
PRODUCT LEDA  
DESIGN ANTONIO CITTERIO

54



55



# Sveva

Carlo Colombo Design

Poltrone | Pouf • Tavolini

**Armchairs | Ottomans • Coffee and Side Tables**

L'inconfondibile carattere della poltrona Sveva si manifesta appieno nella sua elegante silhouette che ne fa intuire la natura generosa ed accogliente.

Una sinuosa scocca realizzata in poliuretano rigido strutturale e successivamente rivestita in cuoio accoglie i soffici cuscini di seduta e schienale imbottiti in piuma d'oca.

La base girevole è in alluminio pressofuso ed è prevista nelle versioni a quattro o cinque razze, quest'ultima espressamente progettata per rispondere alle esigenze del settore contract. Le finiture proposte per la base d'appoggio sono: metallo satinato, cromato, brunito, cromo nero e champagne. Innumerevoli gli abbinamenti che possono essere creati tra la scocca in cuoio disponibile in nove varianti colore ed i rivestimenti dei cuscini, che possono essere realizzati sia in tessuto sia in pelle.

La poltrona Sveva può accompagnarsi all'omonimo poggiatesta.

Il disegno della base d'appoggio ha ispirato anche una serie di tavolini proposti in diverse misure e in una pluralità di finiture che comprendono raffinate essenze, sofisticate laccature e pregiati marmi.

The sophisticated silhouette of the Sveva armchair reveals its unmistakable personality while silently telegraphing its generously welcoming appeal.

A shapely shell made of rigid structural polyurethane and then upholstered in saddle hide accommodates the soft, goose down filled seat and seat back cushions.

The cast aluminum swivel base comes in versions with four or five spokes, the latter specifically designed to meet the needs of the contract market. Finish options for the support base are: satin, chromed, burnished, black chromed and champagne finished metal.

Between the saddle hide shell - available in nine colors - and the cushion upholstery options, that can be created in both fabric and leather, countless combinations are possible.

The Sveva armchair can be paired with its own namesake ottoman.

The design of the base also inspired a series of occasional tables in various sizes and in a number of finishes, including sumptuous wood, exquisite lacquer and luxurious marble.



CATEGORY ARMCHAIRS | OTTOMANS  
PRODUCT SVEVA  
DESIGN CARLO COLOMBO

58



59



CATEGORY COFFEE AND SIDE TABLES | ARMCHAIRS | OTTOMANS  
PRODUCT SVEVA  
DESIGN CARLO COLOMBO

60



61



# Ascanio

Antonio Citterio Design

Tavolini

**Coffee and Side Tables**

Ascanio è un tavolino in legno massello che unisce alla praticità di utilizzo l'attitudine ad inserirsi con misurata eleganza in qualsiasi ambiente.

La struttura in legno consente di spostarlo agilmente all'interno dello spazio living, per poterlo avvicinare al divano o alla poltrona.

Presenta una varietà di raffinate combinazioni materiche tra la struttura che è proposta in massello di noce canaletto o massello di frassino in una pluralità di colorazioni ed il piano che può essere realizzato anch'esso in legno oppure in marmo, nelle varietà Bianco Carrara, Nero Marquina, Calacatta Oro ed Emperador.

Il tavolino Ascanio è disponibile in tre misure.

Ascanio is a solid wood occasional table that not only serves a practical function but also lends an air of discreet elegance to any room.

The table's solid wood structure makes it easy to move around in the living room, for placement near the sofa or an armchair.

A number of tasteful combinations of materials are possible - between the structure in solid Canaletto walnut or solid ash in an array of colors - and the top available in either wood or in several kinds of marble: White Carrara, Black Marquina, Calacatta Gold and Emperador.

The Ascanio occasional table is available in three sizes.



CATEGORY COFFEE AND SIDE TABLES  
PRODUCT ASCANIO  
DESIGN ANTONIO CITTERIO

64



65



# Gustav

Carlo Colombo Design

Tavoli • Tavolini

**Tables • Coffee and Side Tables**

Una famiglia di tavoli e tavolini caratterizzati dalla purezza del disegno e da una grande praticità d'utilizzo.

Ricercati dettagli come l'innesto della gamba con il piano del tavolo celano la complessità costruttiva in una semplicità soltanto apparente. Raffinate le combinazioni materiche tra la struttura in massello di noce canaletto e frassino ed il piano inserito a filo, che può essere realizzato in diverse varietà di marmo: Bianco Carrara, Nero Marquina, Calacatta Oro ed Emperador.

Pensati quali ideali elementi di servizio alle sedute della collezione, i tavolini Gustav mostrano una loro spiccata personalità ed un'attitudine a presentarsi da soli o in gruppo, per meglio valorizzare il gioco delle sovrapposizioni.

Purity of design and functionality are in the design DNA of this family of dining and accent tables.

Sophisticated details, like the leg that inserts into the table top, conceal the complexities of construction under the guise of simplicity. Exquisite combinations of materials are possible between the structure in solid Canaletto walnut and ash and the flush-set top in several kinds of marble: White Carrara, Black Marquina, Calacatta Gold and Emperador.

Designed as the perfect complements to the seating options in the collection, the Gustav side tables have bold personality and a flair for standing alone or in groups, where the interplay of overlapping planes is even more evident.



CATEGORY TABLES  
PRODUCT GUSTAV  
DESIGN CARLO COLOMBO



68



69

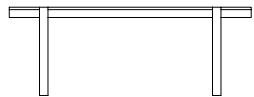

CATEGORY COFFEE AND SIDE TABLES  
PRODUCT GUSTAV  
DESIGN CARLO COLOMBO

70



71



# Spello

Gabriele e Oscar Buratti Design

Tavoli

**Tables**

Due scultoree basi in metallo verniciato conferiscono al tavolo Spello una marcata personalità. Fonte di ispirazione il brutalismo, corrente architettonica ed artistica caratterizzata da forme aspre e asciutte e strutture robuste.

Alla severità della base d'appoggio, si contrappone la poetica matericità del piano in legno massello, enfatizzata dal disegno delle lastre che ricorda la nobile tradizione dell'intarsio e da una sottile fessura che corre in senso longitudinale al piano.

Il tavolo Spello è disponibile unicamente con piano rettangolare impiallacciato nelle finiture in noce canaletto, frassino ed ebano, in molteplici tinte. Prevista anche la variante con piano in marmo in molteplici varietà.

The Spello table – two sculptural bases in painted metal – spells unmistakable personality. The source of inspiration is brutalism, an architectural and artistic movement known for its rugged, raw shapes and robust structures.

Contrasting the severity of the support base is the poetic texture of the solid wood top, played up by the design of the boards that echo the noble tradition of inlay work and by a subtle opening that runs the length of the top.

Available only in rectangular version, the Spello table comes veneered in Canaletto walnut, ash or ebony, in a choice of stains. It is also available in a version with an array of marble top choices.



CATEGORY TABLES  
PRODUCT SPELLO  
DESIGN GABRIELE E OSCAR BURATTI

74



75



# Taylor

Carlo Colombo Design

Contenitori  
**Cabinets**

La famiglia di contenitori Taylor, caratterizzata da una linea essenziale e moderna e da ricercati dettagli costruttivi, si arricchisce di nuovi elementi e finiture.

La leggera struttura è in alluminio brunito mentre le ante a battente o scorrevoli possono essere rivestite in cuoio oppure impiallacciate in noce canaletto, frassino ed ebano, in una varietà di tinte raffinate. Il piano può essere realizzato anch'esso in essenza per ottenere un effetto di continuità con la facciata oppure in marmo per creare invece un garbato contrasto.

I mobili si mantengono leggermente sollevati da terra tramite piedini in metallo brunito.

I contenitori Taylor sono ora disponibili in una pluralità di configurazioni differenti sia a sviluppo verticale che orizzontale, che risponde a diverse esigenze di utilizzo e ne moltiplica le possibilità di collocazione all'interno dell'ambiente domestico, dall'ingresso al living, fino alla zona notte.

Tutti gli elementi si presentano perfettamente finiti anche nella parte posteriore e si prestano pertanto anche ad essere collocati al centro dell'ambiente.

The Taylor family of cabinets, with their sleek, modern lines and sophisticated construction details, adds new pieces and finishes.

The lightweight structure is in burnished aluminum while the hinged or sliding doors can be covered in saddle hide or in Canaletto walnut, ash or ebony veneer, in an array of elegant colors. For a seamless effect with the front, the top can also be crafted in wood, or in marble, for graceful contrast.

The cabinets sit off the floor on burnished metal feet.

The Taylor cabinets are now available in a number of different configurations that extend either vertically or horizontally, to meet varying needs, multiplying the possibilities of placement in the home – from the entry to the living room and all the way to the bedroom.

Flawlessly finished, even on the back, the elements are also at home in the center of a room.



CATEGORY CABINETS  
PRODUCT TAYLOR  
DESIGN CARLO COLOMBO

78



79



# Zefiro

Antonio Citterio Design

Tavoli

**Tables**

L'ampia collezione di tavoli da pranzo Zefiro, caratterizzata da un segno lieve e contemporaneo, vede l'inserimento di una nuova tipologia di piano, che ne amplifica ulteriormente la versatilità.

Un raffinato profilo in metallo incornicia il piano in vetro retro-verniciato in una gamma di eleganti nuance quali bianco seta, caffè, grigio e nero.

Il profilo in metallo è previsto nelle finiture satinato, cromato, brunito, cromo nero, champagne, bianco e nero, in abbinamento alle gambe in alluminio pressofuso, che con la loro linea affusolata conferiscono leggerezza e dinamicità ai tavoli Zefiro.

I tavoli Zefiro con piano in vetro retro-verniciato sono disponibili con piani tondi, quadrati e rettangolari, in svariate misure per soddisfare le esigenze più diverse.

Zefiro is the name of a wide collection of dining tables featuring light, contemporary design now also available with a new top, which makes the Zefiro tables even more versatile than before.

An elegant metal edge frames the retro-painted glass top available in a sophisticated colour palette including silk white, coffee, grey and black.

The metal edge comes in the following finishes: satined, chromed, burnished, black chrome, black and white to match the tapered die-cast aluminium legs, which greatly contribute to the light and dynamic appeal displayed by the Zefiro tables.

The Zefiro dining tables with retro-painted glass tops are available round, square and rectangular as well as in several sizes to meet all requirements.



CATEGORY TABLES  
PRODUCT ZEFIRO  
DESIGN ANTONIO CITTERIO



82

83



# Isabel

Carlo Colombo Design

Poltroncine | Sedie | Sgabelli

**Dining Chairs | Dining Armchairs | Bar Stools**

Lo sgabello Isabel presenta le medesime caratteristiche costruttive delle omonime sedia e poltroncina, presentate al Salone del Mobile lo scorso anno.

È interamente rivestito in cuoio, gambe incluse ed è anch'esso caratterizzato da uno schienale avvolgente ed estremamente confortevole.

Il rivestimento in cuoio è proposto in nove varianti di colore.

Grazie alla sua linea ricercata ed essenziale, lo sgabello Isabel si inserisce armoniosamente sia in contesti residenziali che in progetti hospitality.

With the same construction features as its namesake chair and dining armchair launched at Salone del Mobile 2017, the Isabel bar stool is entirely upholstered in saddle hide.

It also features an extremely comfortable enveloping seat back.

The saddle hide upholstery comes in nine color options.

With its sophisticated yet uncomplicated lines, the Isabel bar stool is confidently at home in both residential and hospitality interiors.



CATEGORY DINING CHAIRS | DINING ARMCHAIRS | BAR STOOLS  
PRODUCT ISABEL  
DESIGN CARLO COLOMBO



86



87

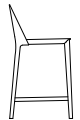

Disegni tecnici in ordine alfabetico  
**Technical drawings in alphabetical order**

Flexform si riserva il diritto di apportare ai propri modelli qualsiasi miglioramento tecnico ed estetico dovesse essere ritenuto opportuno, comprese eventuali modifiche alle dimensioni e ai materiali utilizzati, senza obbligo di preavviso.

Flexform reserves the right to make any technical and aesthetical improvements, which might be considered appropriate or necessary, including changes of sizes and materials, without any obligation of prior notice.

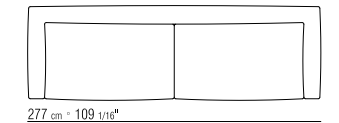
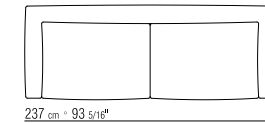
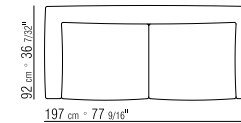
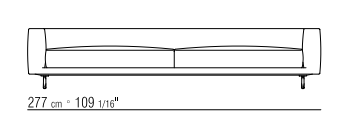
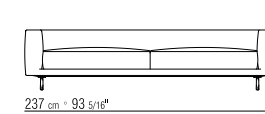
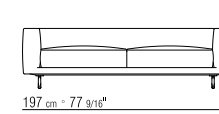
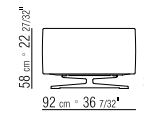
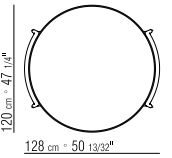
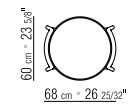
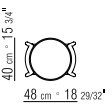
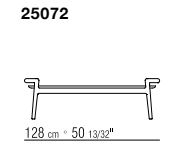
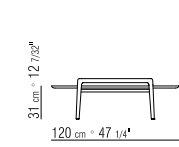
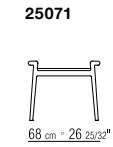
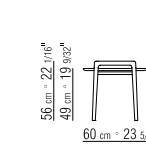
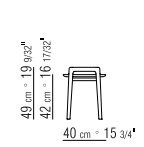
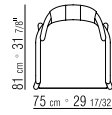
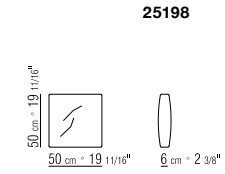
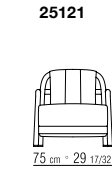
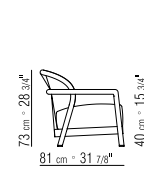
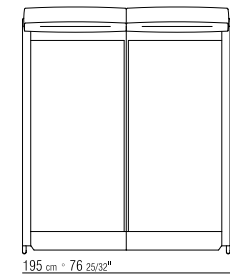
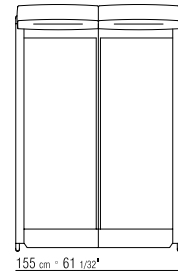
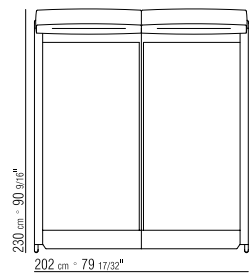
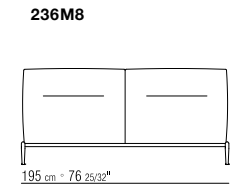
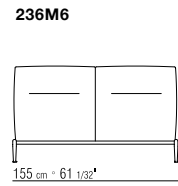
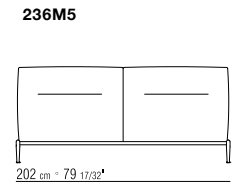
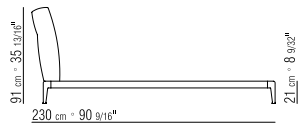
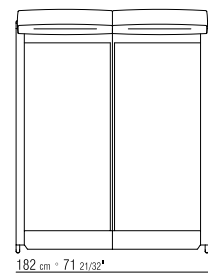
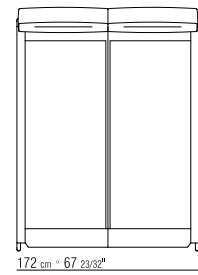
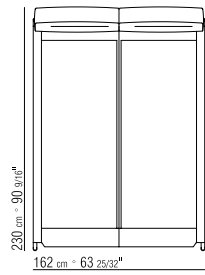
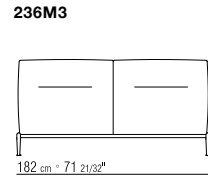
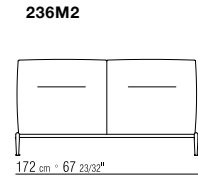
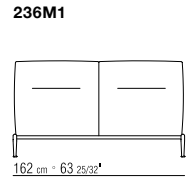
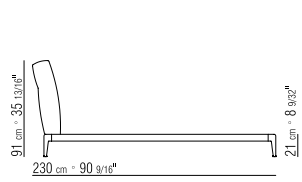

245A5

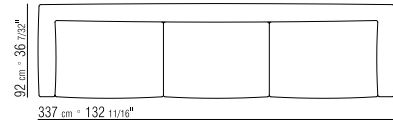
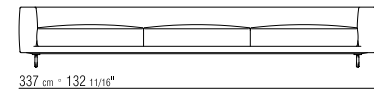

245B1

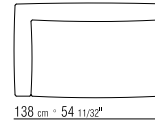
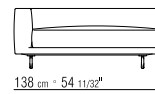

245B3

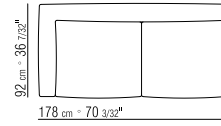
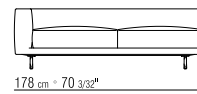

24504

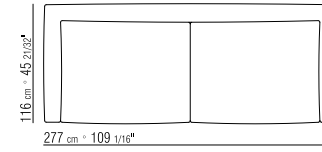
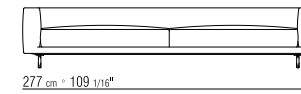
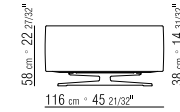

24505

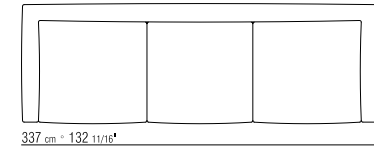
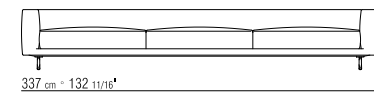

245B5

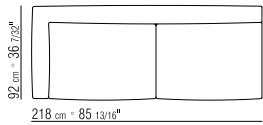
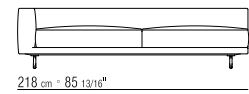
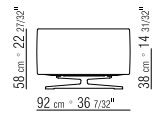

245B7

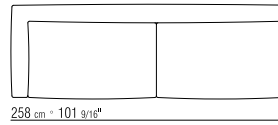
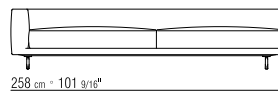

245B9

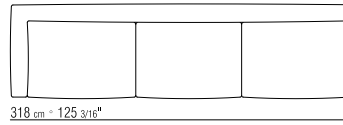
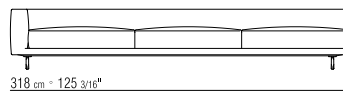

24515

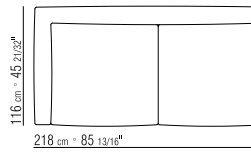
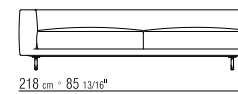
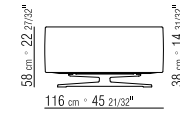

24517

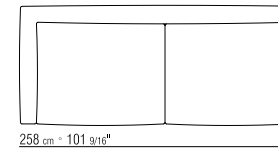
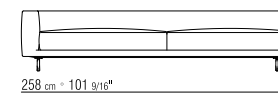

24519

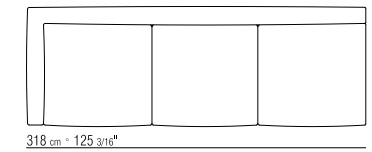
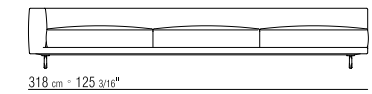

245C1

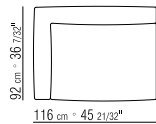
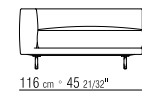
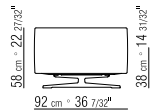

24503

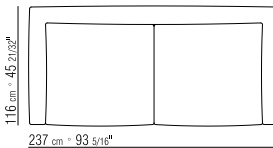
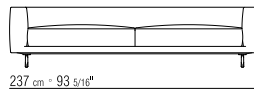
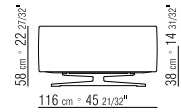

24521

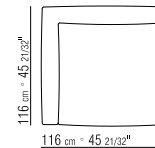
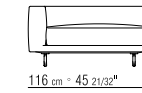
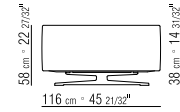

24531

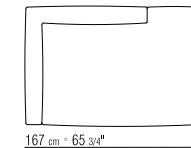
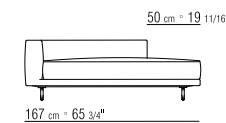

24533

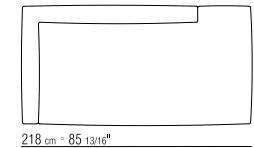
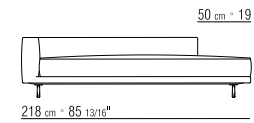

**CAMPIELLO**

DIVANI | DIVANI componibili | POUF • SOFAS | SECTIONAL SOFAS | OTTOMANS

**24550**

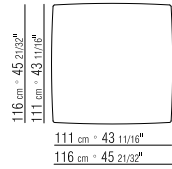
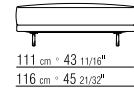
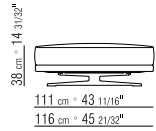

**24551**

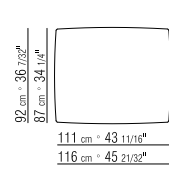
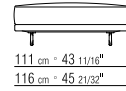
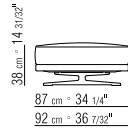

**24594**

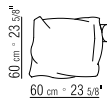

**24595**

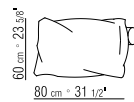

**24596**

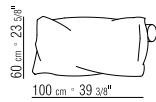

**24597**

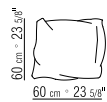

**24598**

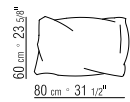

**23502**

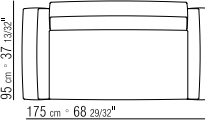
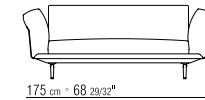
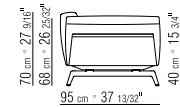

**23503**

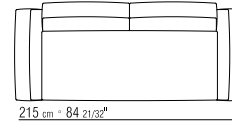
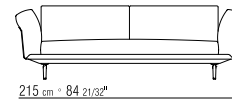

**23504**

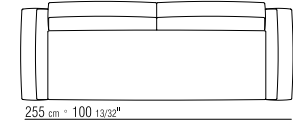
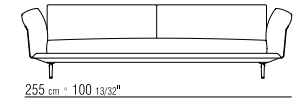

**23513**

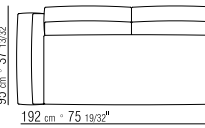
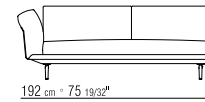
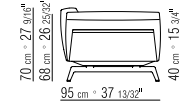

**23515**

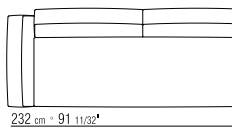
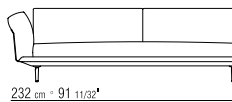

**ESTE**

DIVANI | DIVANI componibili | POUF • TAVOLINI | CONSOLLE • LETTI  
SOFAS | SECTIONAL SOFAS | OTTOMANS • COFFEE TABLES | SIDE TABLES | CONSOLES • BEDS

**235A3**

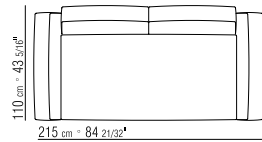
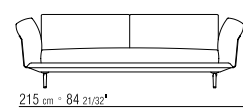
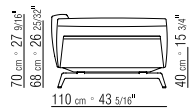

**235A4**

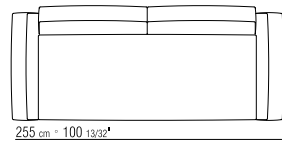
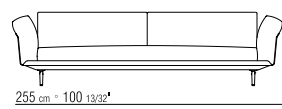

**235A5**

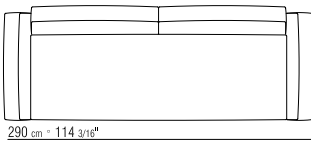
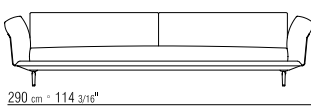

**23525**

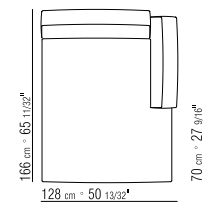
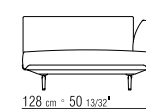
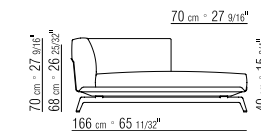

**23527**

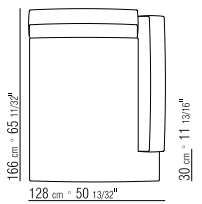
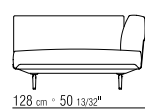
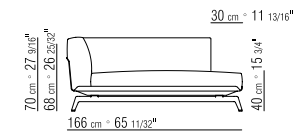

23550

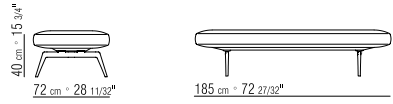

23598

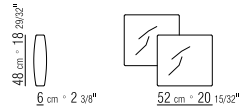

23599

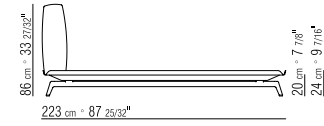
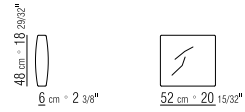

235M1

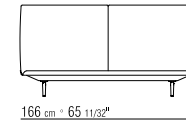

235M2

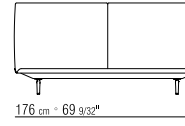

235M3

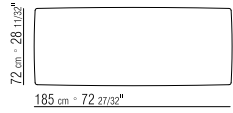
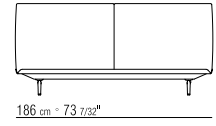

23572

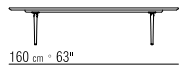
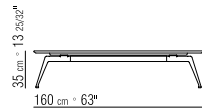

23574

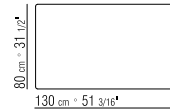
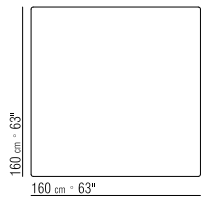
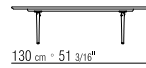
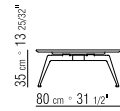

23575

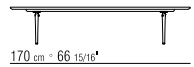
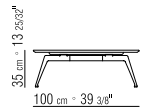

23579

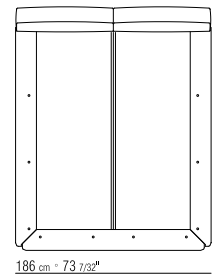
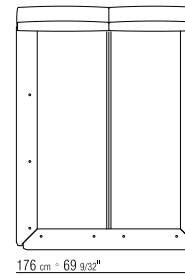
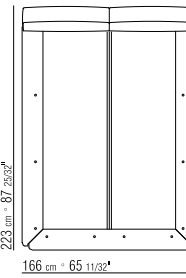
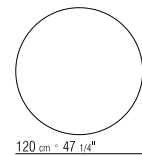
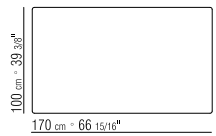
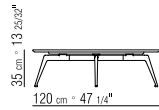

235M5

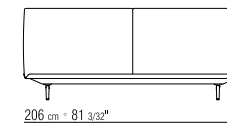

235M6

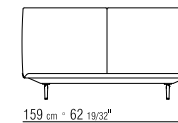

235M8

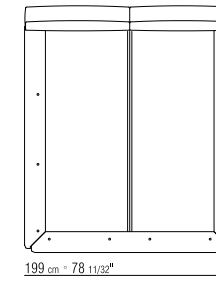
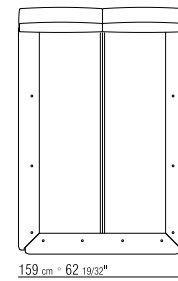
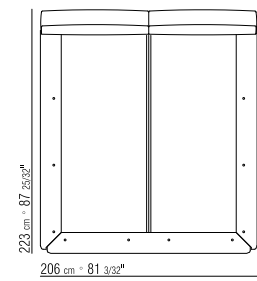
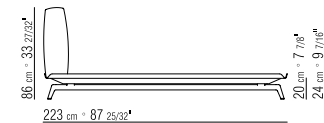
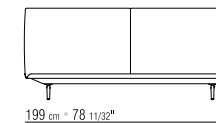

GUSTAV

TAVOLINI | CONSOLE • TAVOLI  
COFFEE TABLES | SIDE TABLES | CONSOLES • TABLES

24970

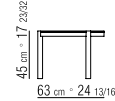
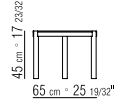
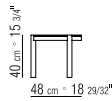
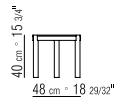

24972

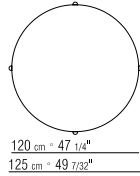
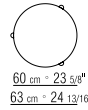
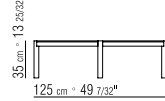

24981

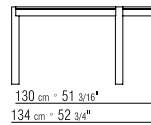
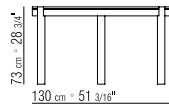

24982

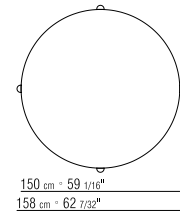
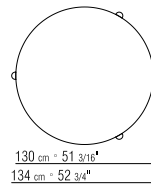
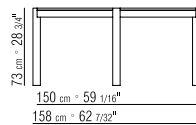

24987

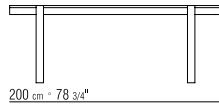
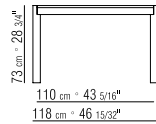

24988

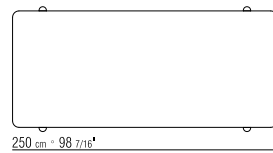
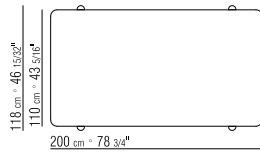
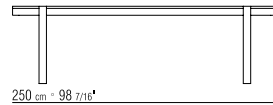
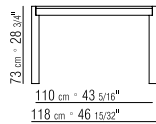

HERA

POLTRONE | POUF • POLTRONCINE | SEDIE | SGABELLI  
ARMCHAIRS | OTTOMANS • DINING CHAIRS | DINING ARMCHAIRS | BAR STOOLS

246A1

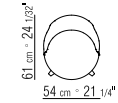
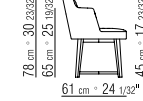

246A2

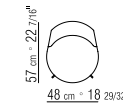
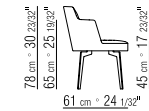

24601

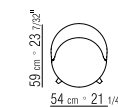
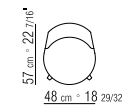
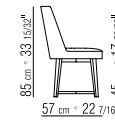

**HERA**

POLTRONE | POUF • POLTRONCINE | SEDIE | SGABELLI  
 ARMCHAIRS | OTTOMANS • DINING CHAIRS | DINING ARMCHAIRS | BAR STOOLS

**24602**



**24612**

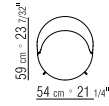
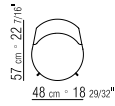

**24621**



**24622**

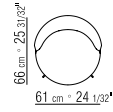
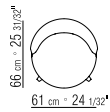

**24631**

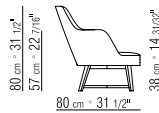

**24632**

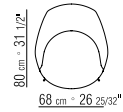
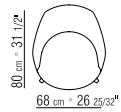
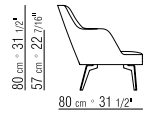

**ISABEL**

POLTRONCINE | SEDIE | SGABELLI • DINING CHAIRS | DINING ARMCHAIRS | BAR STOOLS

**20350**

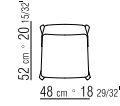
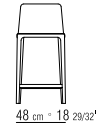
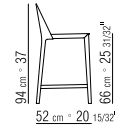

**LEDA**

POLTRONE | POUF • POLTRONCINE | SEDIE | SGABELLI  
 ARMCHAIRS | OTTOMANS • DINING CHAIRS | DINING ARMCHAIRS | BAR STOOLS

**24701**

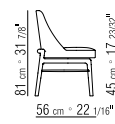

**24711**

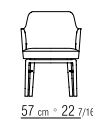
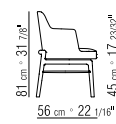

**24703**

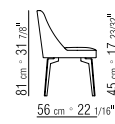

**24713**

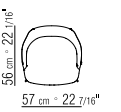
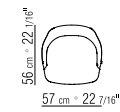
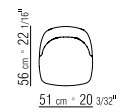

**24721**

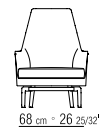
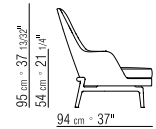

**24731**

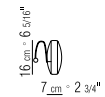
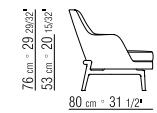

**24799**

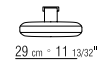
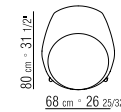
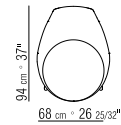
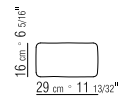

**NEWBRIDGE**

DIVANI | DIVANI COMPONENTI | POUF • LETTI  
SOFAS | SECTIONAL SOFAS | OTTOMANS • BEDS

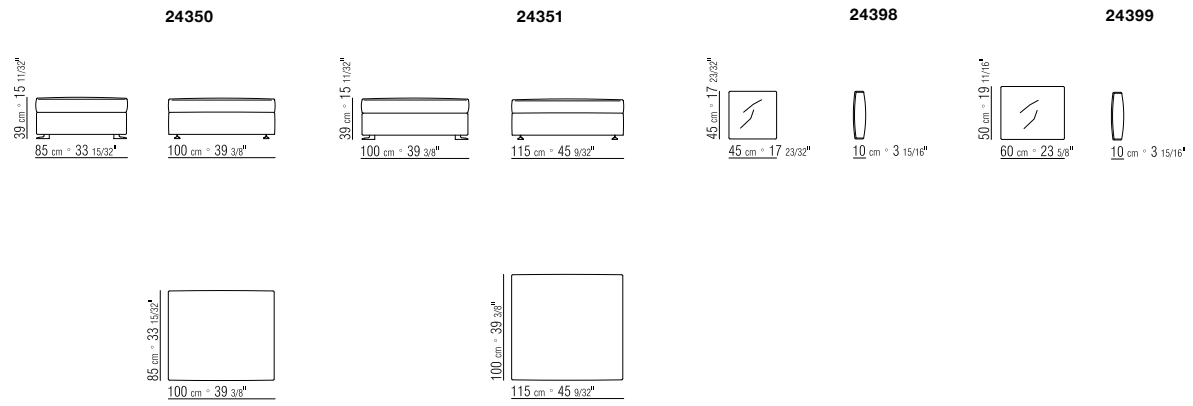
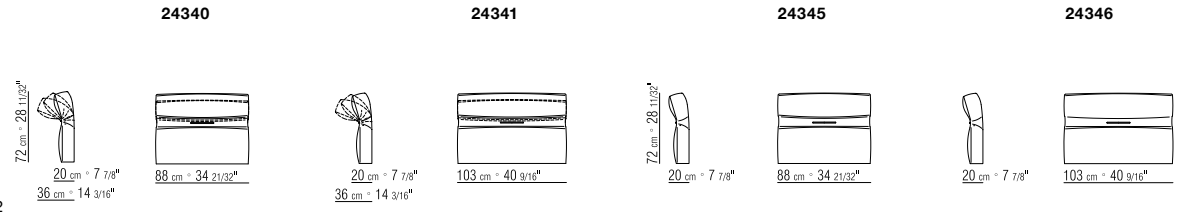
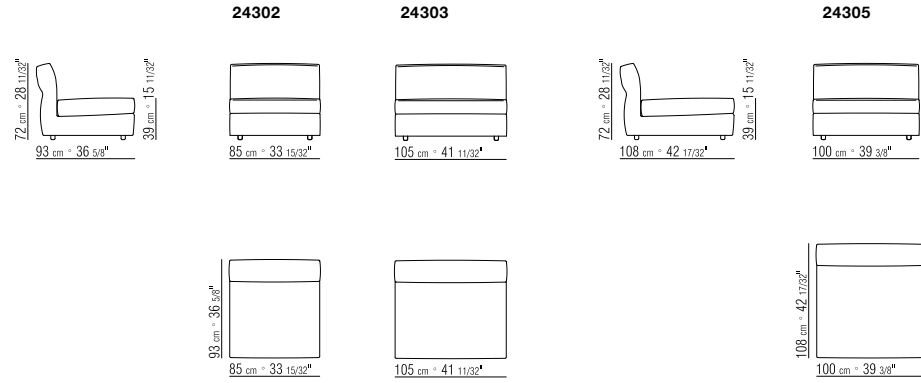

**SVEVA**

POLTRONE | POUF • TAVOLINI | CONSOLE  
ARMCHAIRS | OTTOMANS • COFFEE TABLES | SIDE TABLES | CONSOLES

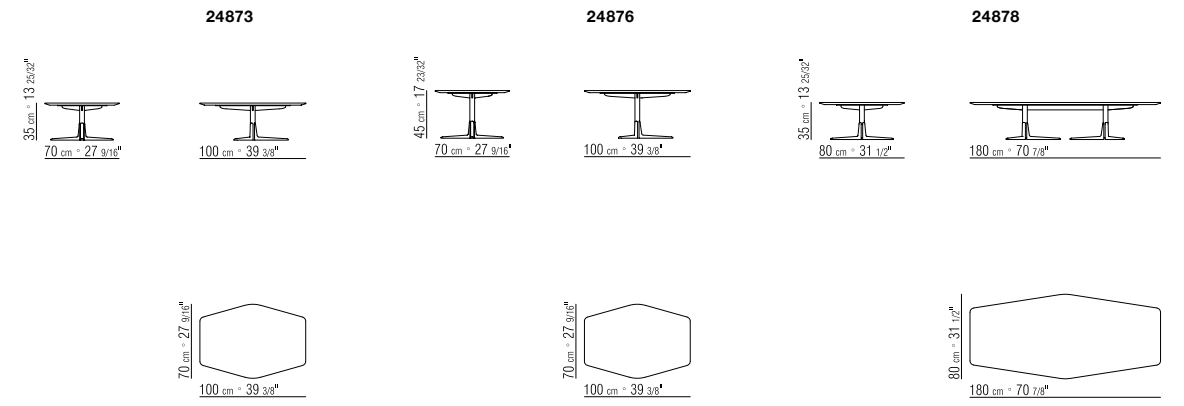
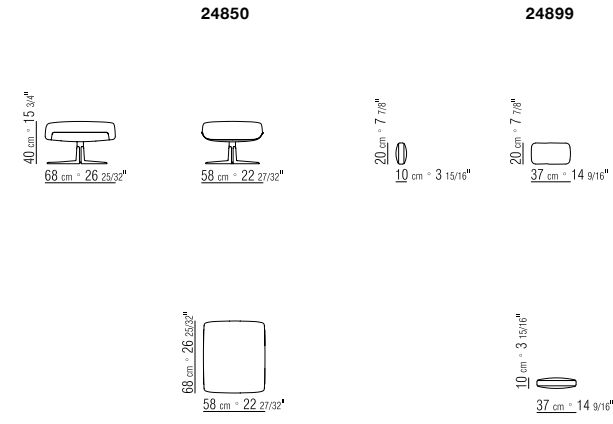
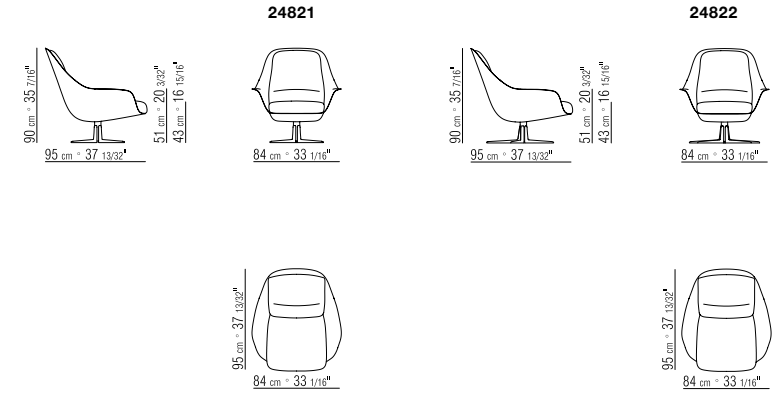

**SVEVA**

POLTRONE | POUF • TAVOLINI | CONSOLLE  
ARMCHAIRS | OTTOMANS • COFFEE TABLES | SIDE TABLES | CONSOLES

**24875**

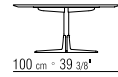
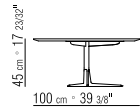

**24872**

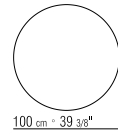
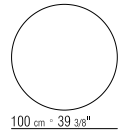
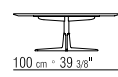
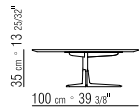

**SPELLO**

TAVOLI • TABLES

**25280**

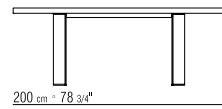
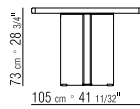

**25281**

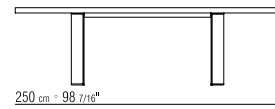

**25282**

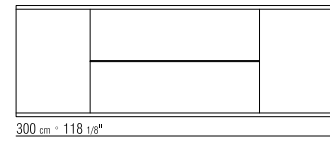
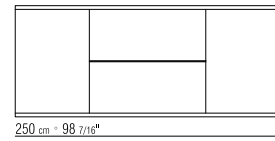
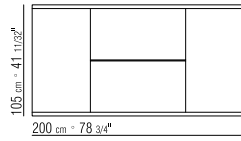
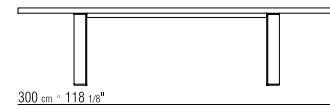

**25285**

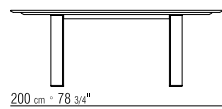
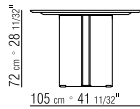

**25286**

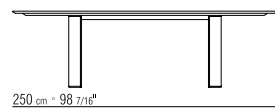

**25287**

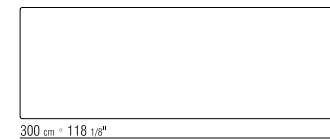
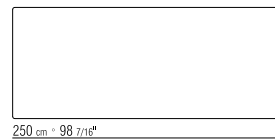
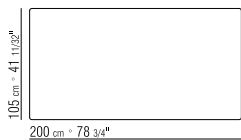

**TAYLOR**

LIBRERIE | CONTENITORI | COMPLEMENTI • BOOKSHELVES | CABINETS | ACCESSORIES

**24162**

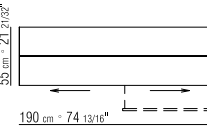
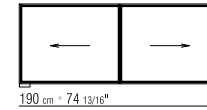
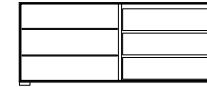

**24164**

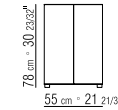
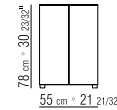
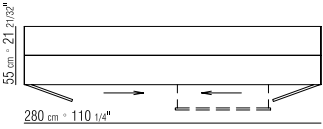
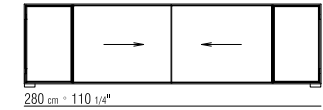

**24166**

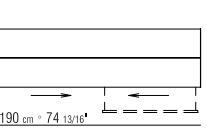
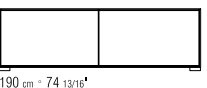
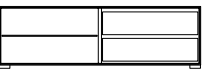

**24167**

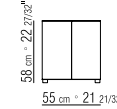
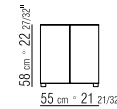
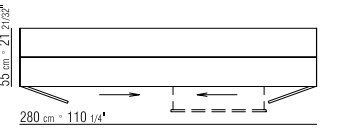
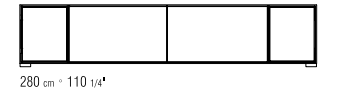

**24179**

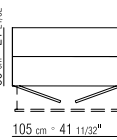
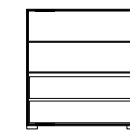
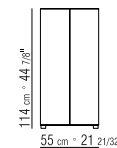

**24159**

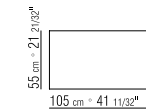
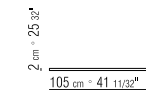

24150

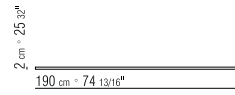
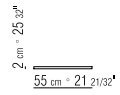

24157

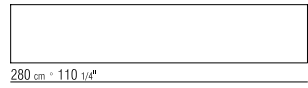
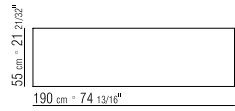
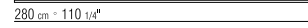

23885

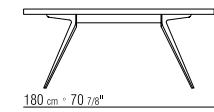
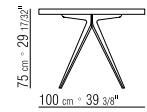

23886

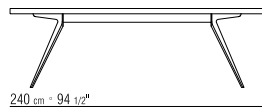

23887

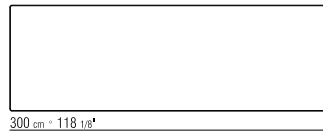
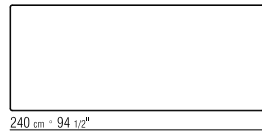
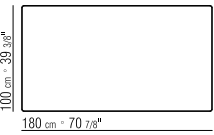
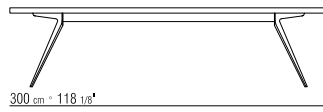

23880

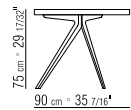

23881

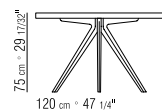

23882

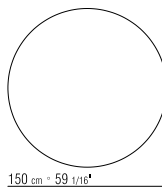
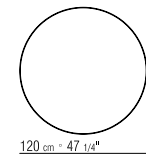
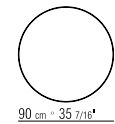
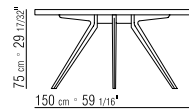

23888

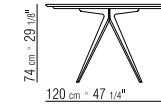
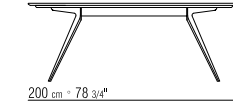

23889

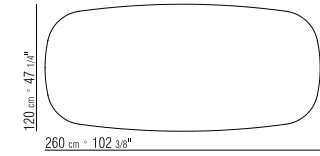
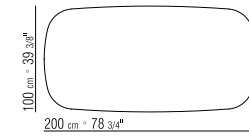
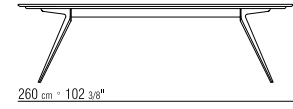

23870

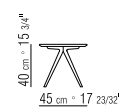

23871

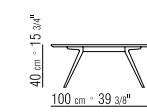

23874

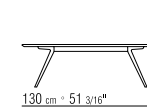
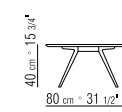

23875

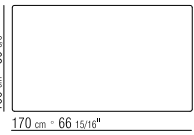
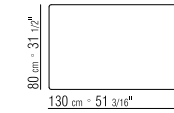
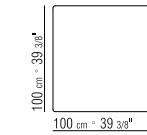
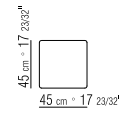
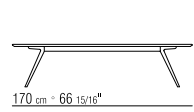
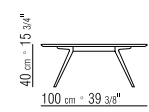

23877



23878

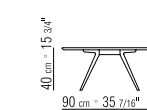

23879

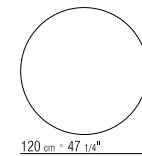
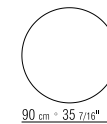
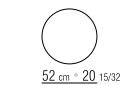
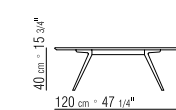

PRINTED IN ITALY  
APRIL 2018

FLEXFORM S.P.A.  
VIA EINAUDI 23/25  
20821 MEDA (MB) ITALIA  
TEL. +39 0362 3991  
INFO@FLEXFORM.IT  
WWW.FLEXFORM.IT



 TÜVRheinland CERTIFIED	Management System ISO 9001:2015	
	www.tuv.com ID 9108635793	

**FLEXFORM**

FLEXFORM | MADE IN ITALY