

Patrizia Volpato®

New forms of light.

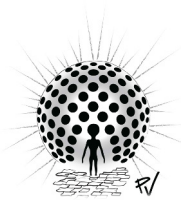

Patrizia Volpato®

New forms of light.



Headquarters

Marghera (Venice)

Italy



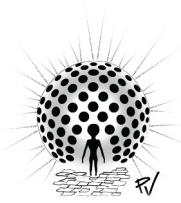

Patrizia Volpato®

New forms of light.

Origins...



The brand *Patrizia Volpato* rises from an artisanal company born in 1980 and focused on the production of high-quality decorative lamps within the design lighting sector.

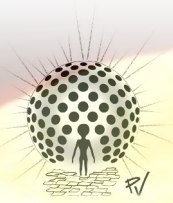

Patrizia Volpato®

New forms of light.

...Present Time

Whilst still referring to the ancient craftsmanship of Murano glassblowing, *Patrizia Volpato* became an elegant blend of traditions and modernity for different styles.

Today the company designs and produces its own collections as well as custom-made fixtures.

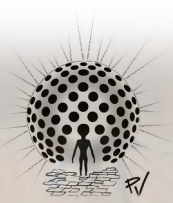

Patrizia Volpato®

New forms of light.

Customers

Patrizia Volpato has a solid customer base, in Italy and abroad, represented by:

- general contractors,
- architectural firms,
- international hotels,
- contractors for interior design,
- cruise ships,
- furniture companies,
- fashion brands,
- private residences.

Only some of the many key references:

- Permasteelisa – Engineering & Building Contractor
- Geneva Bank and TV headquarters (Switzerland)
- Hotel Lutetia (Paris, France)
- Hotel Millenium (Amman, Jordan)
- Hotel Marriot (Montreal, Canada)
- Hotel Ambassador (Tbilisi, Georgia)
- Fincantieri – Shipbuilding Contractor
- Holland American Line – Cruise ships
- P&O cruises – Cruise ships
- Francesco Molon – Furniture sector
- Fendi – Fashion sector

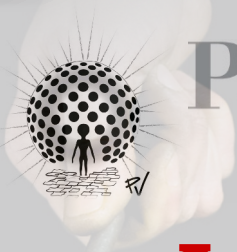

Patrizia Volpato®

New forms of light.

Vision

Patrizia Volpato wants to be the first choice
within the lighting sector for its

- outstanding products
- precise service
- remarkable creativity
- strong commitment
- total dedication

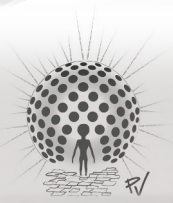

Patrizia Volpato®

New forms of light.

Mission & Core Values

Deliver lighting solutions that are:

- excellent
- artisanal
- elegant
- inspiring

Technicality and artistry combine with the following core values:

- efficiency
- expertise
- flexibility
- reliability
- accuracy
- care for details





Patrizia Volpato®

New forms of light.

Facts & Figures

5,5 days
average answer
time for quotation

>500
quotations done in
one year

35%
of export sales

32
countries
where the brand
is directly sold

70%
of sales =
customized
products

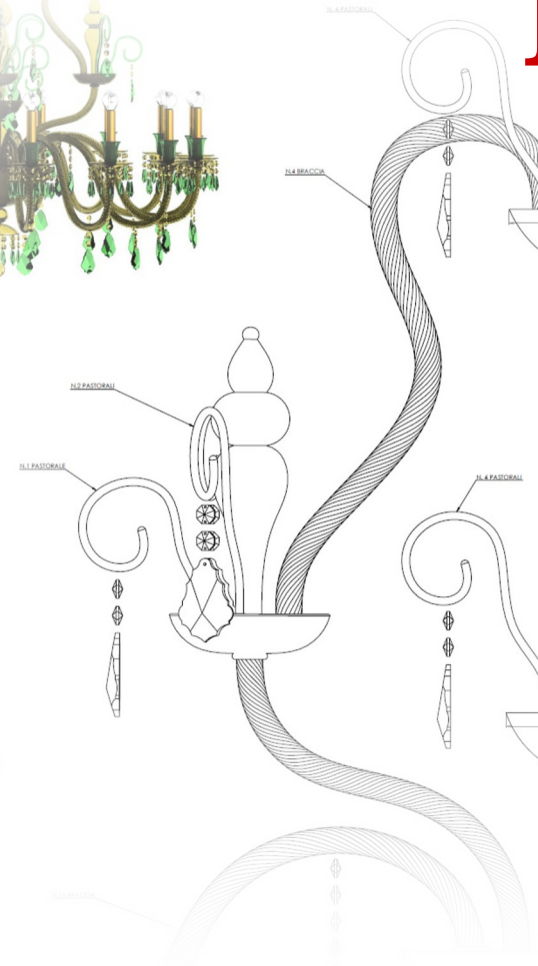



Patrizia Volpato®

New forms of light.

Innovation



Patrizia Volpato also developed a monitoring platform quick and easy to use that, by means of Bluetooth technology, enables to manage the switching on and off as well as many other functions of any light fixture.

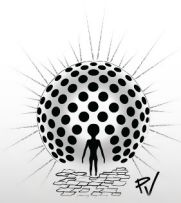

Patrizia Volpato®

New forms of light.

Payoff

Patrizia Volpato actually presents itself as a brand capable of offering “New forms of light”, yet never forgetting the importance of traditional artisanal working methods from which it gets constant inspiration for its original and authentic installations.



Patrizia Volpato®

New forms of light.

Claim

Walt Disney used to say:

“If you can dream it,
you can do it”

VS

Patrizia Volpato's claim is:

“If you can imagine it,
we can make it happen!”



Patrizia Volpato®

New forms of light.

Technical Office

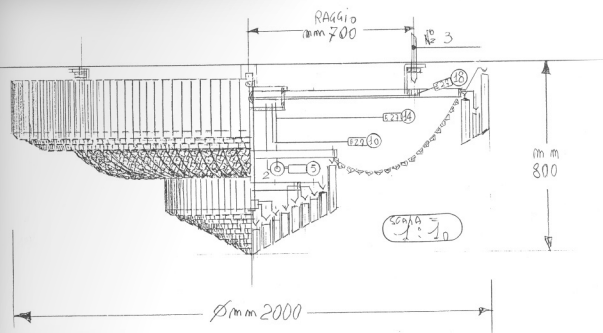

Patrizia Volpato's technical office offers a 360° consultancy, beginning with the feasibility studio, going through the executive project and getting to the finished product, using 3D modelling tools for realistic renderings as well as refined photographs for the final approval given by the customer.



Over the years the Company has acquired specific skills related to a wide range of manufacturing processes and materials such as: glass, crystal, methacrylate, LED, fiber optics, Barrisol sheets, metal and more.

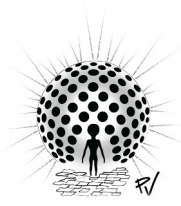

Patrizia Volpato®

New forms of light.

Production Process



It is composed of various phases with different plants, here below the most important ones.



- 1 technical office, 9 workers in total
- 3 glassmaking plants, 40 workers in total
- 7 mechanical workshops, 41 workers in total
- 4 galvanic and varnishing workshops, 29 workers in total
- 2 quality control offices, 9 workers in total

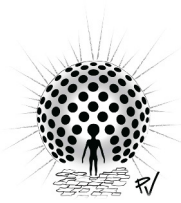

Patrizia Volpato®

New forms of light.

Tailor~made: steps

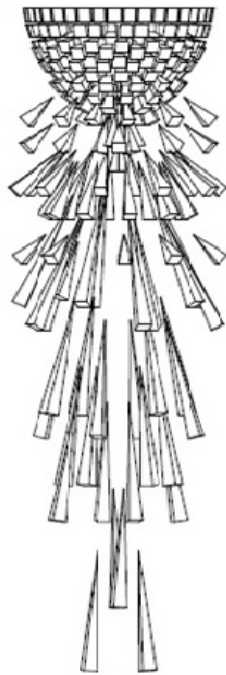
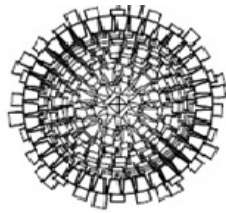

Patrizia Volpato has qualified technicians who can develop **any tailor~made creation** according to the following steps:

1. Incoming request (from ideas, photos, sketches)
2. Shop drawing
3. 3D modelling + Research & Development
4. Rendering with various proposals for alternative solutions
5. Production of the item
6. Assembly instructions of the item
7. Packaging of the item
8. Fitting of the item

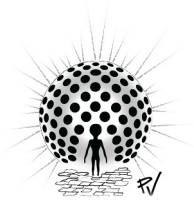

Patrizia Volpato®

New forms of light.

Finished item: features

- Refined and exclusive design
- Artisan procedures with utmost attention to details
- High quality materials
- Endurance notwithstanding time
- Forefront technologies and processing
- LED for energy saving
- Domotics for major monitoring and comfort
- Compliant with EU norms: CE + RoHS = safety
- International certifications when required (e.g.UL)
- Availability of spare parts and assistance
- Shipping all over the world, adequate packaging



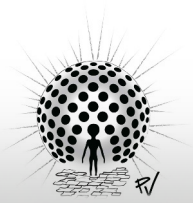

Patrizia Volpato®

New forms of light.



**Some Views
from the
«Custom»
Catalogue**



Private Villa ~ South Africa



Salone del
Mobile
Euroluce
2013

—

Milan, Italy



Hotel Lutetia

Paris, France

The image shows a grand, ornate interior space, likely a library or study hall. The ceiling is highly decorative with a repeating pattern of gold-colored medallions. A large, multi-tiered chandelier hangs from the center. The walls are light-colored with gold trim and feature several large, arched windows and doorways. In the foreground, there are several round tables with modern office chairs. A large, dark circular graphic is overlaid on the right side of the image, containing white text.

Luiss
University
~
Rome,
Italy



Building
in Kaskad Plaza
~
Dnepropetrovsk,
Ukraine

A person in a grey hoodie is working at a long wooden table in a workshop. The table is supported by wooden sawhorses. The background shows a workshop environment with various tools and equipment. The entire image has a green color cast.

Geneva Bank and Local TV
headquarters ~ Switzerland
(work in progress)

Geneva Bank and Local TV headquarters ~ Switzerland *(final result)*





Carnival Cruise Line

Carnival Sunrise 5979



Holland America Line

Nieuw Statendam 6244



Patrizia Volpato®

New forms of light.

«Famous Quotes»

Gomorra is an Italian TV series created by the writer Roberto Saviano, based on the homonymous novel: rival clans that fight each other to control illegal trafficking.

The series was a great success and its rights were sold in over 60 countries. The setting is characterized by sumptuous villas that are enriched with chandeliers coming from *Patrizia Volpato's* flagship line: «Cristalli».



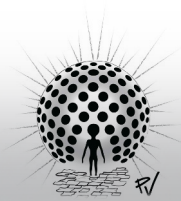

Patrizia Volpato®

New forms of light.

**Some Views
from the
«Collections»
Catalogues**





Cristalli

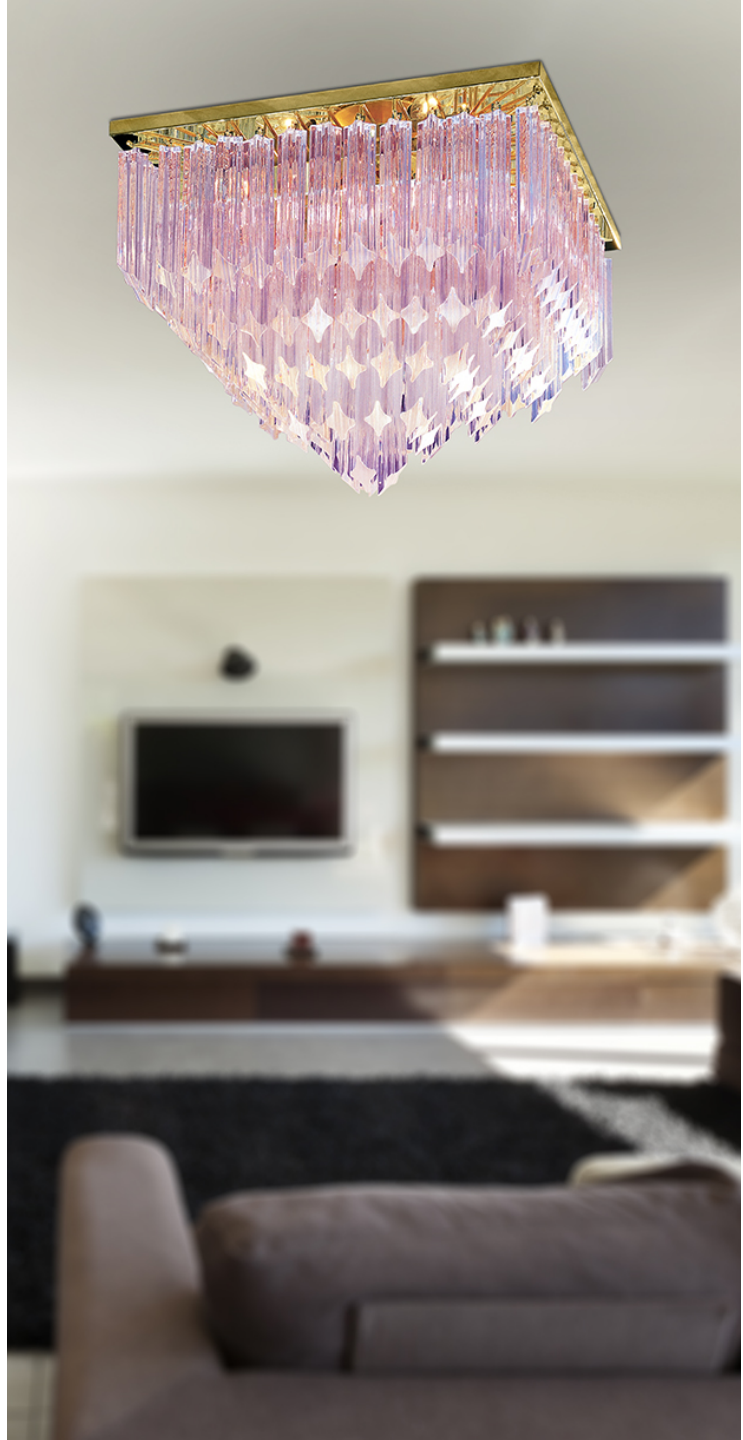



Riflessi

A photograph of a grand piano in a room with a large chandelier and a window with curtains, framed by a torn paper effect. The piano is black and has its lid open. A music book is on the stand. The chandelier is large and ornate, with many small lights. The room has a window with curtains and a patterned rug. The entire scene is framed by a white, torn paper border.

Venezia



Rondo

Crypto



Petali





Fedi



Aline

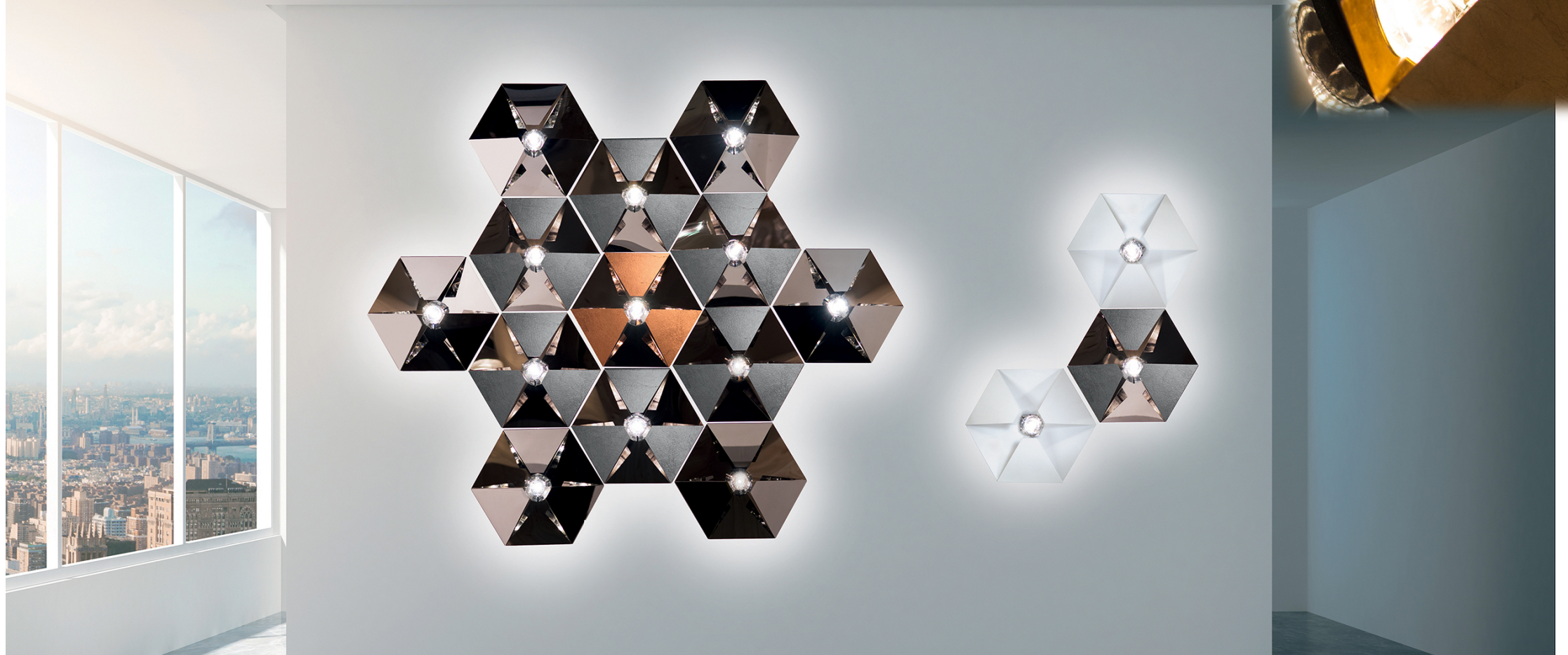



Sfera

Glace



Stone



*Luna
Nuova*





Diamante

Flow





Iride

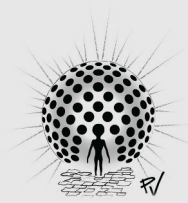

Patrizia Volpato®

New forms of light.

Web

<https://www.patriziavolpato.it/>



@patriziavolpatolighting

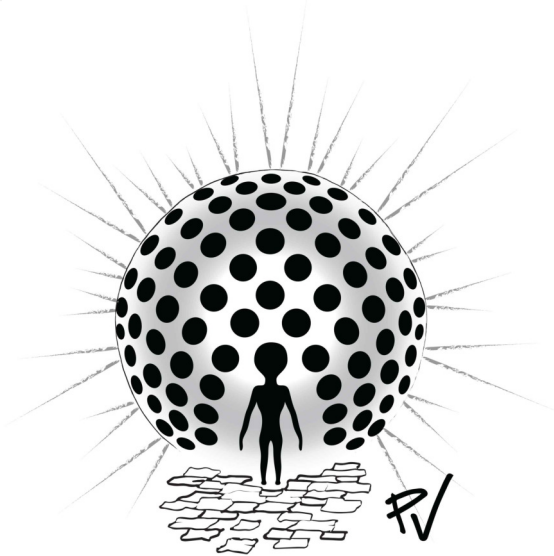

Patrizia Volpato®

New forms of light.

Thank you for your
kind attention!