

— NEW GENERATION SPACE
Collection

ERBA

— New generation space

— C'era una volta la cameretta,
un ambiente che esprimeva
un'idea di infanzia
che oggi non esiste più.

I tempi sono cambiati
e anche gli spazi
si devono adeguare, trasformare,
soddisfare sempre
nuove esigenze e desideri.

L'arredamento delle nuove
generazioni cresce insieme a loro,
si arricchisce di funzioni e soluzioni,
si veste di colori e sensazioni
in continua evoluzione.

Uno spazio da vivere e inventare
ogni giorno, ogni notte,
anno dopo anno.

EN Once upon a time there was the kids' bedroom, a space that represented the idea of childhood that no longer exists today. Times have changed and spaces have to adapt, change and always satisfy new needs and desires. Furniture addressed to the present generation enriches with functions and solutions and fits new colours and feelings in continuous evolution. A space to live and create every day, every night, year after year.

FR Il était une fois la chambre d'enfants, un espace qui exprimait l'idée d'enfance et qui n'existe plus aujourd'hui. Les temps ont changé et aussi les espaces doivent s'adapter, changer et toujours satisfaire de nouvelles exigences et désirs. Le mobilier adressé à la génération courante s'enrichit de fonctions et de solutions et il se vête de couleurs et sensations en constante évolution. Un espace à vivre et inventer tous les jours, tous les nuits, année après année.

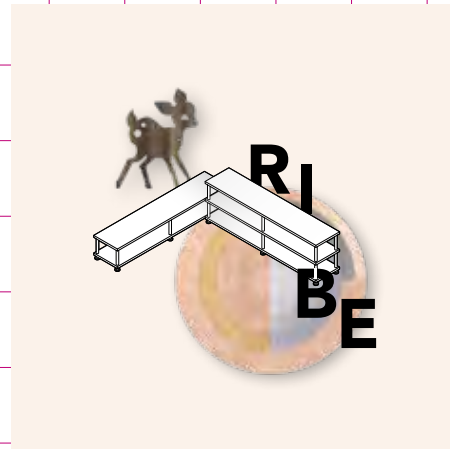

— Modularità nel tempo

EN Modularity by the time
FR Adaptabilité dans le temps

Page. 4

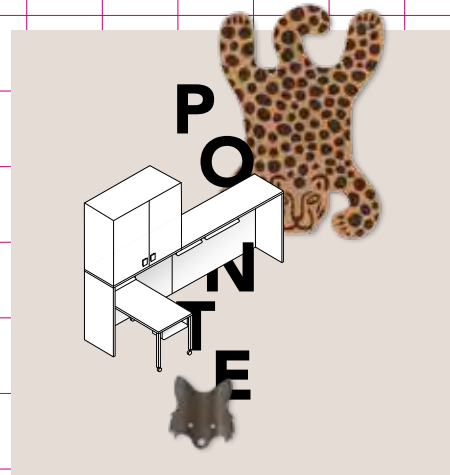

— Costruire sopra

EN Design over
FR Concevoir au-dessus

Page. 14

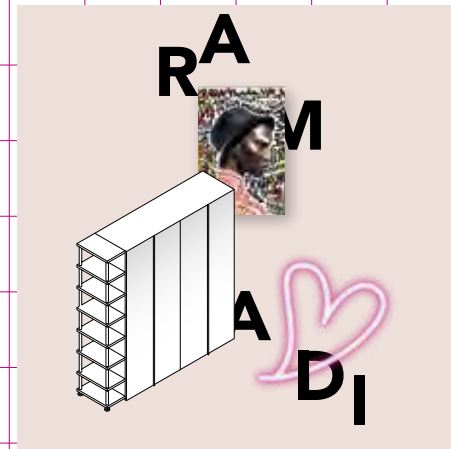

— Funzionalità sempre di moda

EN Fashionable functionality
FR Fonctionnalité toujours à la mode

Page. 94

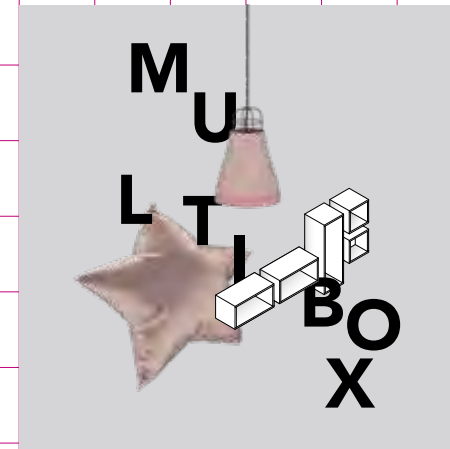

— Contenimento versatile

EN Versatile storage
FR Rangement polyvalent

Page. 24



— Colori, finiture, dati tecnici

EN Colours, finishes, technical informations
FR Couleurs, finitions, informations techniques

Page. 102

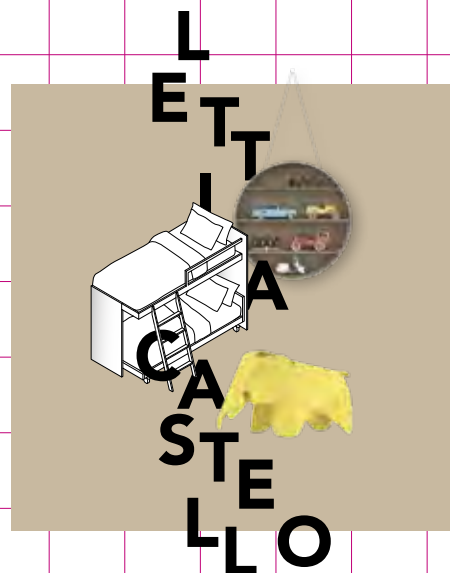

— Condivisione riuscita

EN Successful sharing
FR Partage réussi

Page. 38

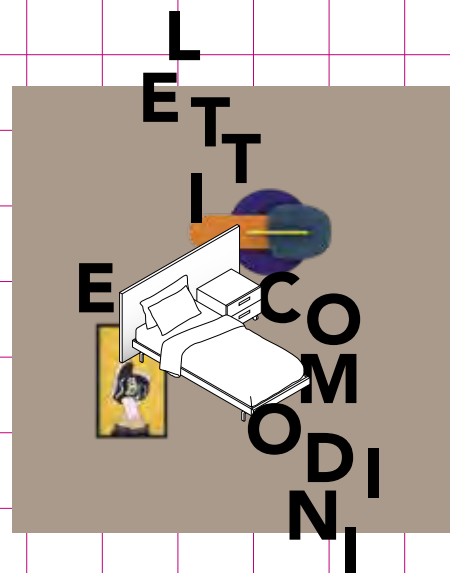

— Sognare a colori

EN Dream in colour
FR Rêver en couleurs

Page. 60

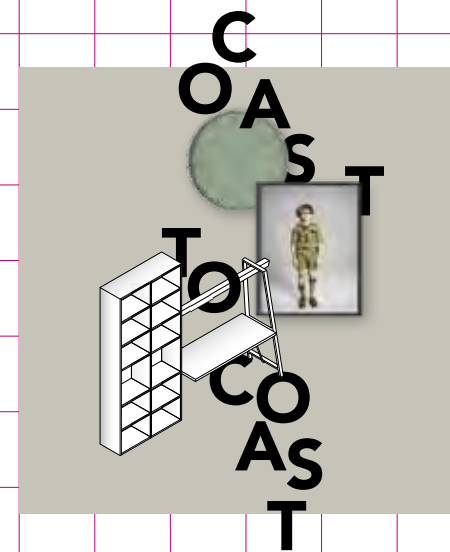

— Illuminazione geniale

EN Brilliant lighting
FR Eclairage géniale

Page. 48

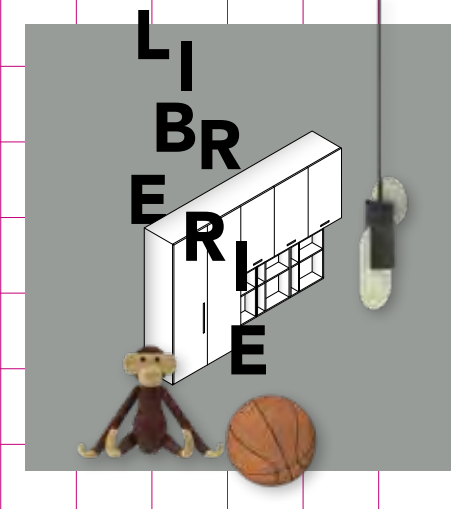

— Orizzontale e verticale

EN Horizontal and vertical
FR Horizontal et vertical

Page. 70

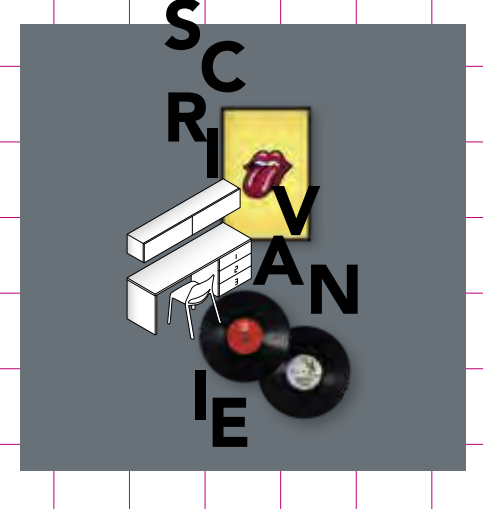

— Studio creativo

EN Creative studying
FR Etude créative

Page. 84

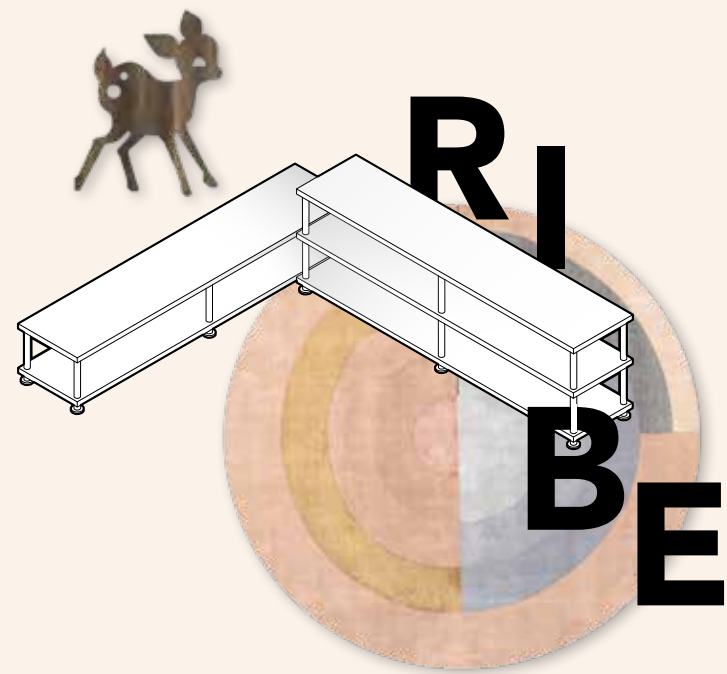

MODULARITÀ NEL TEMPO

— RIBE:
un progetto unico,
semplice, durevole, con
uno stile che si adatta
a tanti gusti e ambienti
diversi, mantenendo
un'identità originale e
riconoscibile.

EN MODULARITY BY THE TIME

RIBE: a unique, simple and long-lasting project, with a style adaptable to many tastes and different spaces, keeping its original and distinctive identity.

FR ADAPTABILITE DANS LE TEMPS

RIBE: un projet unique, simple et durable, avec un style qui convient à de nombreux goûts et différents intérieurs, en gardant une identité originale et reconnaissable.





— Composizione 1

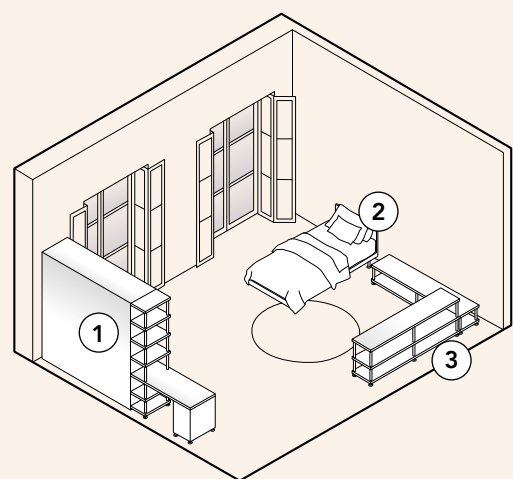

①

IT Armadio, libreria e piano scrittoio tutti integrati.
EN Wardrobe, bookshelf and desk, everything integrated.
FR Armoire, bibliothèque et bureau tous intégrés.

②

IT Letto RIBE con piedi in legno d'acero.
EN RIBE bed with maple wood feet.
FR Lit RIBE avec pieds en érable.

③

IT Libreria RIBE: semplice, funzionale, versatile, con gestione personalizzata dei piani.
EN RIBE bookshelf: simple, functional, versatile, with customized shelves.
FR Bibliothèque RIBE: simple, fonctionnelle, polyvalente, avec une gestion personnalisée des étagères.



— Composizione 1



①

IT Libreria terminale RIBE con piano scrittoio.
EN RIBE final bookshelf with desk.
FR Bibliothèque finale RIBE avec bureau.

②

IT Pouf RIBE.
EN RIBE pouf.
FR Pouf RIBE.

③

IT Armadio FREESTYLE con maniglia RIBE M18.
EN FREESTYLE wardrobe with M18 RIBE handle.
FR Armoire FREESTYLE avec poignée RIBE M18.

④

IT Letto RIBE SYSTEM FH 10.
EN RIBE bed SYSTEM FH 10.
FR Lit RIBE SYSTEM FH 10.



④



⑤

⑤

IT Libreria RIBE.
EN RIBE bookshelf.
FR Bibliothèque RIBE.

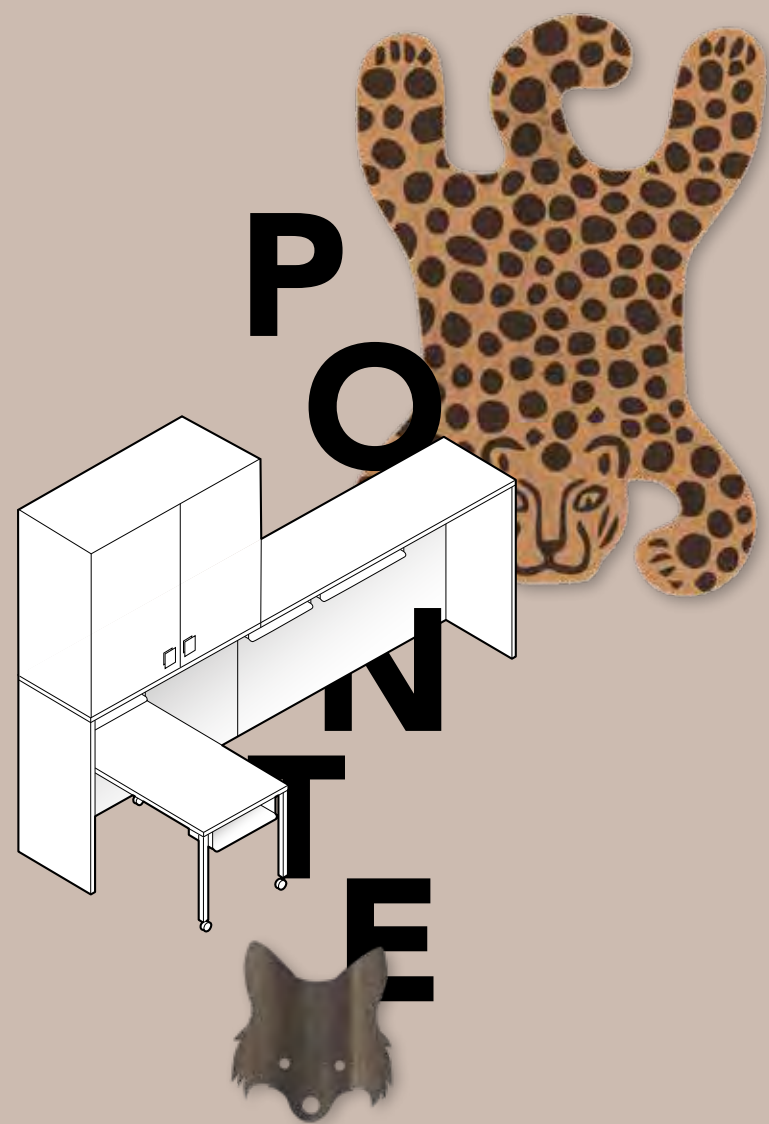

COSTRUIRE SOPRA

— PONTE:
unisce la praticità di una classica
struttura salvaspazio,
con una trave multifunzionale
Coast to Coast,
uno scrittoio su ruote,
un letto e dei moduli di
contenimento superiore,
tutti indipendenti e integrabili
nel tempo.

EN DESIGN OVER

BRIDGE UNIT: it combines the practicality of a space-saving solution, with the multifunctional rail Coast to Coast, a desk on wheels, a bed and the upper storage units. All these elements are independent and can be integrated over time.

FR CONCEVOIR AU-DESSUS

PONT: une solution qui joint la commodité d'une traditionnelle structure gain de place, avec la barre multifonctionnelle Coast to Coast, un bureau avec roulettes, un lit et des armoires au-dessus. Éléments indépendants qui peuvent être intégrés dans le temps.



— **Composizione 2**

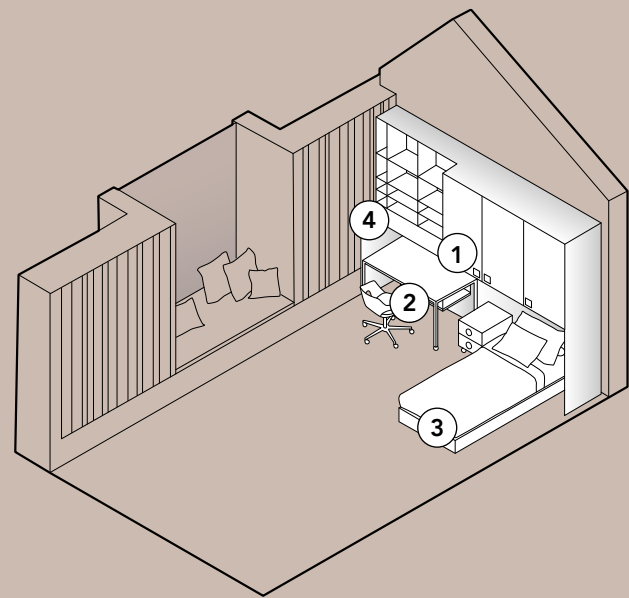

①

IT Struttura a ponte con trave COAST TO COAST, libreria e armadio, combinabili tra loro per dimensioni e finiture.
EN Bridge unit with COAST TO COAST rail, bookshelves and storage units, that can be combined with each others for sizes and finishes.
FR Pont avec barre COAST TO COAST, bibliothèques et armoires, combinables entre eux en termes de dimensions et de finitions.

②

IT Scrivania con gambe in metallo su ruote con freno, disponibile in diverse misure e finiture.
EN Desk with metal legs on wheels with brake, available in different sizes and finishes.
FR Bureau avec pieds en métal et roulettes avec frein, disponible en différentes dimensions et finitions.

③

IT Letto con contenitore o rete fissa disponibile in diverse misure e finiture.
EN Bed with storage base or fixed base available in different sizes and finishes.
FR Lit avec rangement ou sommier fixe disponible en différentes dimensions et finitions.

④

IT Trave COAST TO COAST con illuminazione e appendiabiti integrati, per creare una semplice e funzionale cabina armadio.
EN COAST TO COAST rail with lighting and hanging system integrated. A simple and functional closet in the kids' bedroom.
FR Barre COAST TO COAST avec éclairage et tringle portemanteaux intégrées. Un dressing simple et fonctionnel dans la chambre des enfants.







①

IT Scrivitoio con gambe in metallo su ruote.
EN Desk with metal legs and wheels.
FR Bureau avec pieds en métal et roulettes.

②

IT Sedia con meccanismo di alzata e cuscino.
EN Chair with seat height adjustment and pad.
FR Chaise avec hauteur réglable et coussin.

③

IT Struttura a ponte con trave COAST TO COAST.
EN Bridge unit with COAST TO COAST rail.
FR Pont avec barre COAST TO COAST.

④

IT MULTIBOX pensili.
EN Hanging units MULTIBOX.
FR MULTIBOX suspendus.

⑤

IT Comodino con maniglia M11.
EN Night table with M11 handle.
FR Chevet avec poignée M11.

⑥

IT Moduli ponte con maniglia M12.
EN Bridge units with M12 handle.
FR Modules pont avec poignée M12.

⑦

IT Letto SYSTEM FH 19.
EN Bed SYSTEM FH 19.
FR Lit SYSTEM FH 19.



CONTENIMENTO VERSATILE

— MULTIBOX:
offre infinite combinazioni
di elementi modulari per
creare tante diverse possibilità
di contenimento e inserirsi
in ogni spazio.

EN VERSATILE STORAGE

MULTIBOX: this system offers limitless combinations of units to create many storage possibilities and suit each space.

FR RANGEMENT POLYVALENT

MULTIBOX: combinaisons infinies de modules pour créer différentes possibilités de rangement et s'adapter à n'importe quel espace.







— Composizione 3

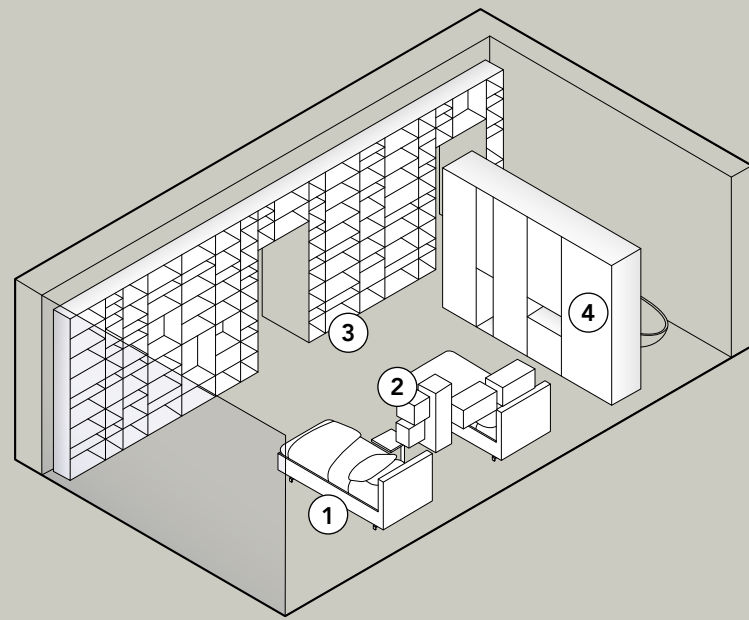

①

IT Letto in tessuto sfoderabile con contenitore o rete fissa.
EN Textile bed available with storage base or fixed base.
FR Lit en tissu déhoussable, disponible avec rangement ou sommier fixe.

②

IT Sistema MULTIBOX di contenitori pensili, base o su ruote, in molteplici configurazioni e finiture.
EN MULTIBOX is a system of hanging units, base units or units on wheels, available in different configurations and finishes.
FR Système MULTIBOX de modules suspendus, de base ou sur roulettes, disponibles en plusieurs configurations et finitions.

③

IT LIBRERIA 2.2, un sistema flessibile nelle dimensioni e negli abbinamenti tra finiture diverse.
EN BOOKSHELF 2.2, a flexible system both for sizes and combinations of different finishes.
FR BIBLIOTHEQUE 2.2, un système flexible en termes de dimensions et de combinaisons entre différentes finitions.

④

IT Armadio FREESTYLE con ante dotate di apertura push e moduli MULTIBOX integrati.
EN FREESTYLE wardrobe with push-pull doors and MULTIBOX units integrated.
FR Armoire FREESTYLE avec portes ouverture push-pull et modules MULTIBOX intégrés.



IT Pouf sagomato.
EN Shaped pouf.
FR Pouf modelé.



IT Comodino su ruote.
EN Night table on wheels.
FR Chevet avec roulettes.



IT Comodino UP.
EN UP night table.
FR Chevet UP.







①

IT Carta da parati METEO bianco.
EN METEO bianco wallpaper.
FR Papier peint METEO bianco.

②

IT Comodino UP.
EN UP night table.
FR Chevet UP.

③

IT MULTIBOX pensili.
EN Hanging units MULTIBOX.
FR MULTIBOX suspendus.

④

IT Letto SYSTEM FH 28.
EN Bed SYSTEM FH 28.
FR Lit SYSTEM FH 28.

⑤

IT Scrivania con gamba in metallo.
EN Desk with metal leg.
FR Bureau avec pied en métal.

⑥

IT Sedia con meccanismo di alzata e cuscino.
EN Chair with seat height adjustment and pad.
FR Chaise avec hauteur réglable et coussin.

⑦

IT Libreria 2.2.
EN Bookshelf 2.2.
FR Bibliothèque 2.2.

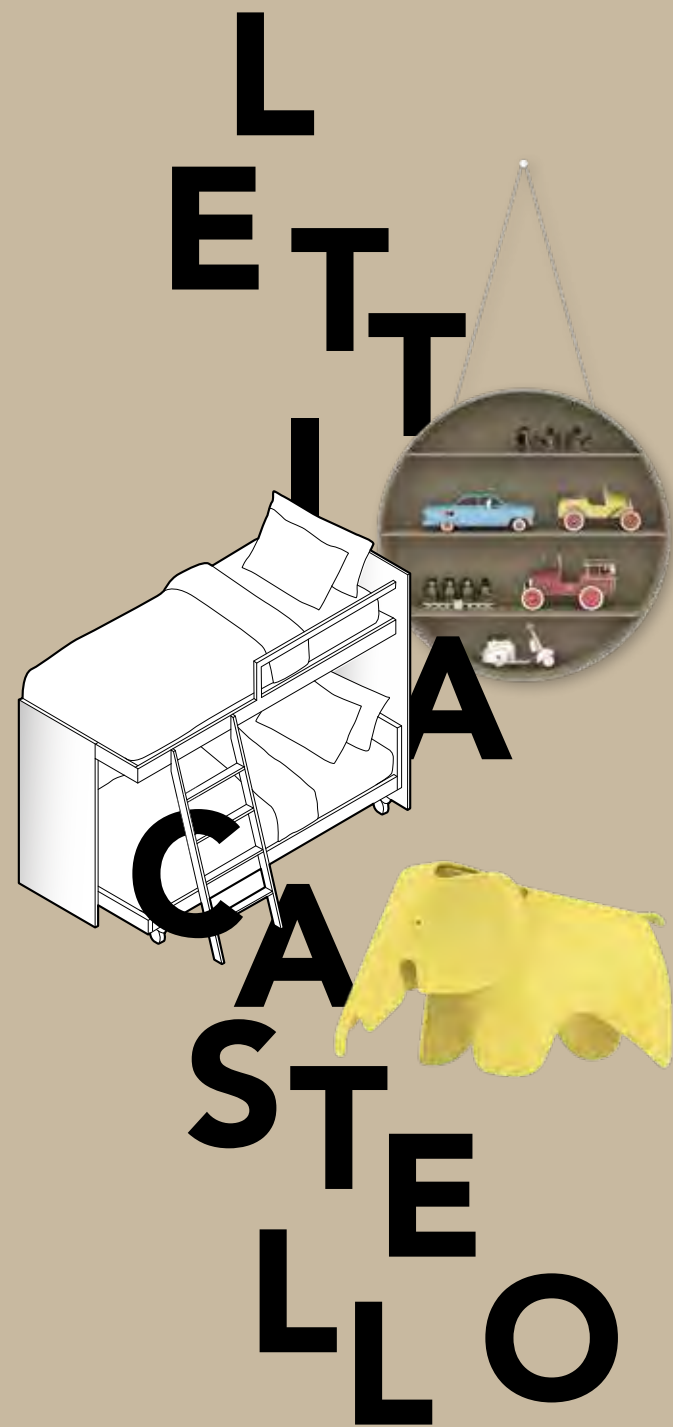

CONDIVISIONE RIUSCITA

— Letti a castello,
una soluzione versatile
che si inserisce
in ogni spazio e incontra
ogni gusto.
Un sistema integrabile
con altri elementi,
per comporre scenari
di vita a due.

EN SUCCESSFUL SHARING

*Bunk bed, a versatile solution that suits every space and meets each taste.
A system that can be integrated with other units, to create two life's space.*

FR PARTAGE REUSSE

*Lits superposés, une solution polyvalente qui s'adapte à n'importe quel espace
et satisfait tous les goûts. Un système qui peut être intégré avec d'autres
éléments, pour créer des solutions à partager à deux.*





— **Composizione 4**

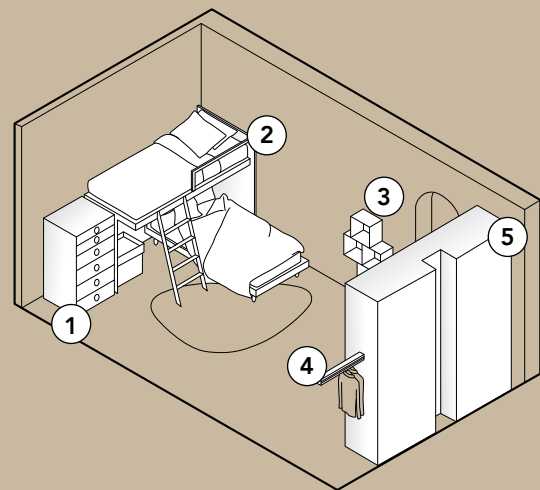

①

IT MULTIBOX con cassetti di altezza diversa per un pratico e funzionale contenimento.
EN MULTIBOX unit with drawers of different heights for a practical and functional storage.
FR MULTIBOX avec tiroirs de différentes hauteurs pour un rangement pratique et fonctionnel.

②

IT Letto a castello con letto inferiore indipendente e scala facilmente spostabile per creare spazi funzionali nella camera.
EN Bunk bed with independent lower bed and ladder easy to move for creating functional spaces in the bedroom.
FR Lits superposés avec lit bas indépendant et échelle facilement déplaçable pour créer des espaces fonctionnels dans la chambre.

③

IT Contenitori sovrapposti MULTIBOX.
EN Overlapping units MULTIBOX.
FR Modules MULTIBOX superposés.

④

IT Trave multifunzionale COAST TO COAST.
EN Multifunctional rail COAST TO COAST.
FR Barre multifonctionnelle COAST TO COAST.

⑤

IT Armadio FREESTYLE.
EN FREESTYLE wardrobe.
FR Armoire FREESTYLE.



IT Contenitori MULTIBOX.
EN MULTIBOX units.
FR Modules MULTIBOX.



IT Comodino con vassoio.
EN Night table with tray.
FR Chevet avec plateau.





①

IT Armadio FREESTYLE con maniglia M11.
EN FREESTYLE wardrobe with M11 handle.
FR Armoire FREESTYLE avec poignée M11.

②

IT Trave multifunzionale COAST TO COAST.
EN Multifunctional rail COAST TO COAST.
FR Barre multifonctionnelle COAST TO COAST.

③

IT Contenitori MULTIBOX.
EN MULTIBOX units.
FR Modules MULTIBOX.

④

IT Cassettiera MULTIBOX con maniglia M11.
EN Drawers unit MULTIBOX with M11 handle.
FR Bloc tiroirs MULTIBOX avec poignée M11.

⑤

IT Comodino con vassoio.
EN Night table with tray.
FR Chevet avec plateau.

⑥

IT Letto a castello.
EN Bunk bed.
FR Lits superposés.

⑦

IT Letto SYSTEM FH 10.
EN Bed SYSTEM FH 10.
FR Lit SYSTEM FH 10.



ILLUMINAZIONE GENIALE

— **COAST TO COAST:**
la trave tecnologica
che illumina e arreda
lo spazio, creando
soluzioni tanto originali
quanto funzionali.

EN BRILLIANT LIGHTING
COAST TO COAST: a technological rail to light up and furnish the interior,
creating solutions as original as functional.

FR ECLAIRAGE GENIALE
COAST TO COAST: la barre innovatrice qu'illumine et décore l'intérieur au
même temps, en créant des solutions aussi originales que fonctionnelles.







— **Composizione 5**

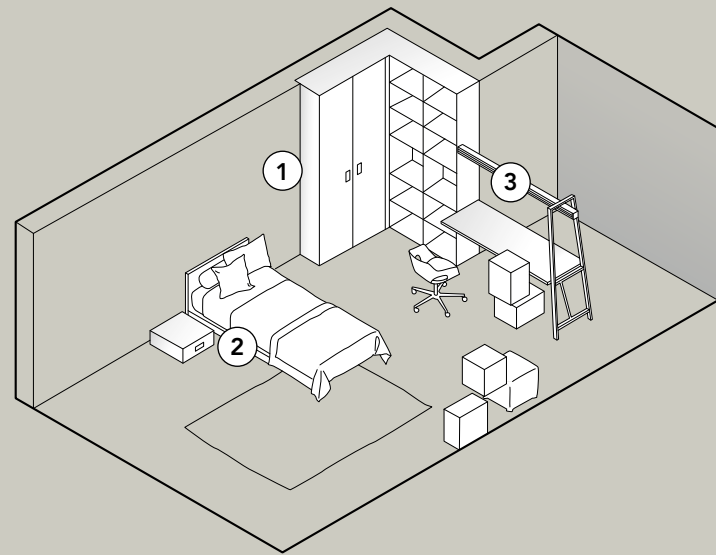

①

IT Composizione angolare con armadio FREESTYLE e libreria 2.2.

EN Corner solution with FREESTYLE wardrobe and bookshelf 2.2.

FR Solution d'angle avec armoire FREESTYLE et bibliothèque 2.2.

②

IT Letto e comodino disponibili in tutte le finiture.

EN Bed and night table available in all finishes.

FR Lit et chevet disponibles dans toutes les finitions.

③

IT Scrivania con cavalletto e trave COAST TO COAST con illuminazione a LED e ganci appendiabiti.

EN Desk with trestle and COAST TO COAST rail with LED lighting and coat hooks.

FR Bureau avec chevalet et barre COAST TO COAST avec éclairage LED et crochets portemanteaux.





①

IT Contenitori MULTIBOX.
EN MULTIBOX units.
FR Modules MULTIBOX.

②

IT Pouf.
EN Pouf.
FR Pouf.

③

IT Comodino con maniglia M13.
EN Night table with M13 handle.
FR Chevet avec poignée M13.

④

IT Letto SYSTEM FH 10.
EN Bed SYSTEM FH 10.
FR Lit SYSTEM FH 10.

⑤

IT Armadio FREESTYLE con maniglia M13.
EN FREESTYLE wardrobe with M13 handle.
FR Armoire FREESTYLE avec poignée M13.

⑥

IT Sedia con meccanismo di alzata e cuscino.
EN Chair with seat height adjustment and pad.
FR Chaise avec hauteur réglable et coussin.

⑦

IT Libreria 2.2.
EN Bookshelf 2.2.
FR Bibliothèque 2.2.

⑧

IT Scrivania con cavalletto e trave COAST TO COAST.
EN Desk with trestle and COAST TO COAST rail.
FR Bureau avec chevalet et barre COAST TO COAST.

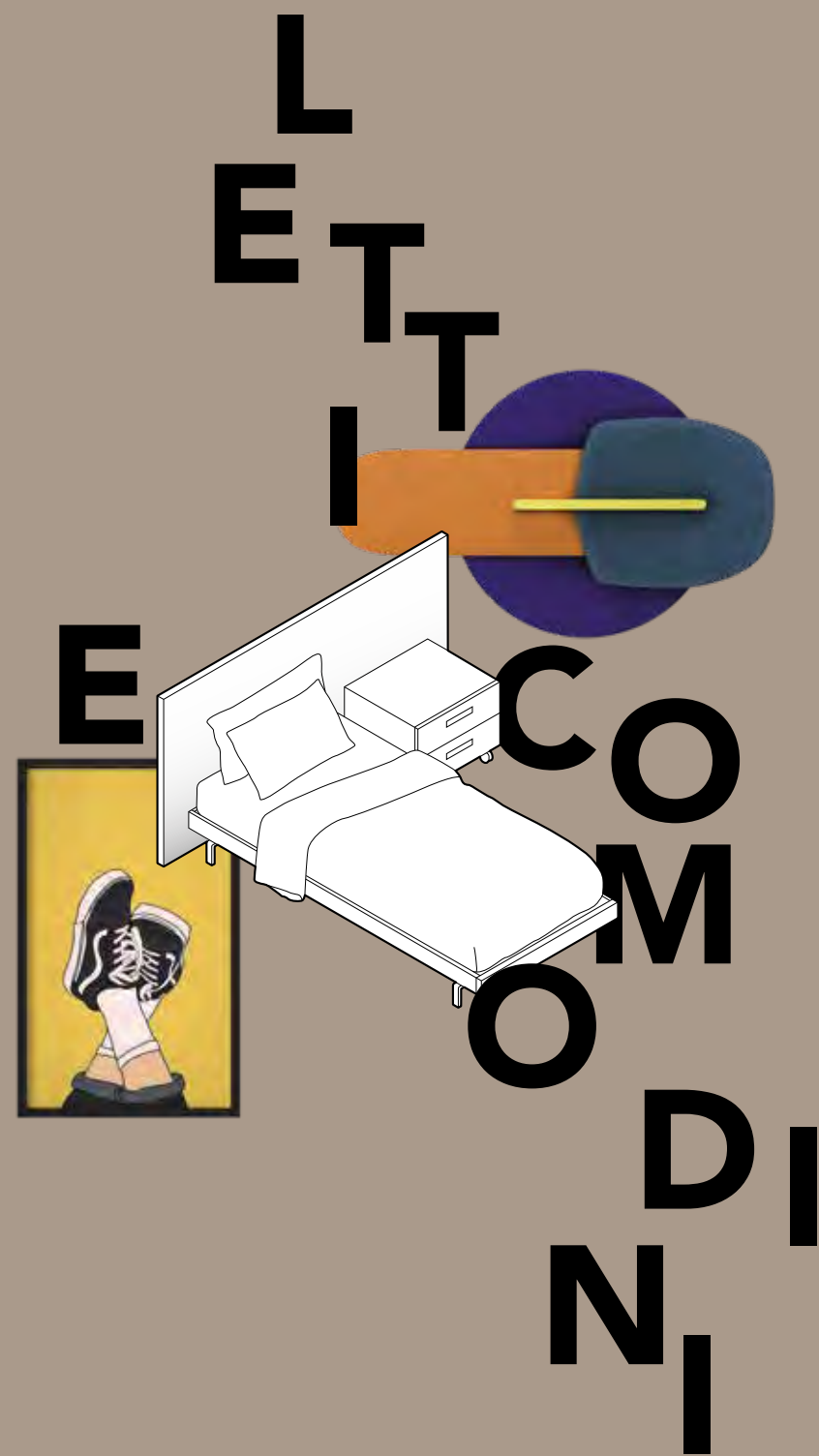

SOGNARE A COLORI

— Non solo
letti e comodini,
ma anche
grandi pannelli di testata
che si possono personalizzare
in quanto a colori
e dimensioni.

EN DREAM IN COLOUR
Not only beds and night tables, but also headboards you can customize with different finishes and sizes.

FR REVER EN COULEURS
Pas seulement des lits et des chevet, mais aussi des têtes de lits qu'on peut personnaliser avec différentes finitions et dimensions.





— **Composizione 6**

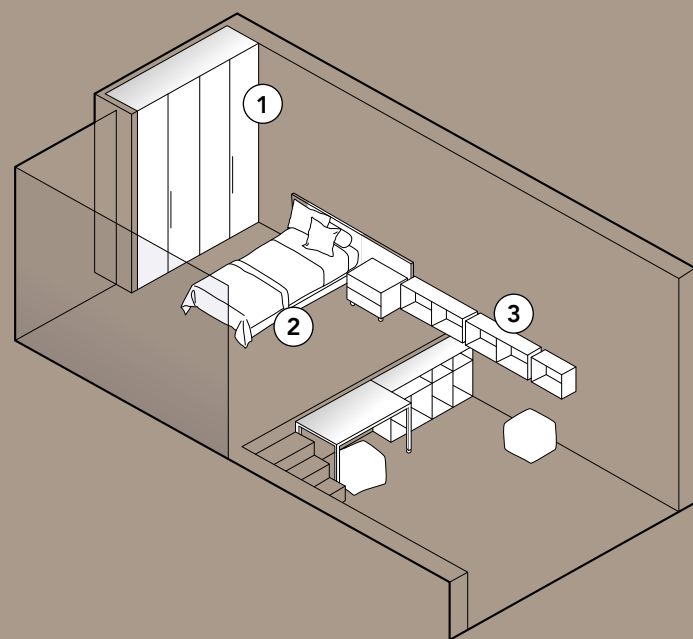

①

IT Armadio FREESTYLE disponibile in diverse configurazioni e con dimensioni su misura.

EN FREESTYLE wardrobe available in different models and also with made-to-measure sizes.

FR Armoire FREESTYLE disponible en différentes variantes et aussi sur-mesure.

②

IT Letto con pannello di testata in tessuto.

EN Bed with textile headboard.

FR Lit avec panneau de tête en tissu.

③

IT Area scrittoio con contenitori pensili e base MULTIBOX.

EN Desk area with hanging and base units MULTIBOX.

FR Espace bureau avec modules MULTIBOX suspendus et de base.





①

IT Armadio FREESTYLE con maniglia M1.
EN FREESTYLE wardrobe with M1 handle.
FR Armoire FREESTYLE avec poignée M1.

②

IT Letto SYSTEM FH 10.
EN Bed SYSTEM FH 10.
FR Lit SYSTEM FH 10.

③

IT Comodino con maniglia M1.
EN Night table with M1 handle.
FR Chevet avec poignée M1.

④

IT Pannello al metro quadro in tessuto.
EN Textile panel per square metre.
FR Panneau en tissu au mètre carré.

⑤

IT Scrivania con gambe in metallo su ruote.
EN Desk with metal legs and wheels.
FR Bureau avec pieds en métal et roulettes.

⑥

IT Contenitori MULTIBOX.
EN MULTIBOX units.
FR Modules MULTIBOX.

⑦

IT Pouf.
EN Pouf.
FR Pouf.

⑧

IT Carta da parati RIGA argilla / nebbia.
EN RIGA argilla / nebbia wallpaper.
FR Papier peint RIGA argilla / nebbia.

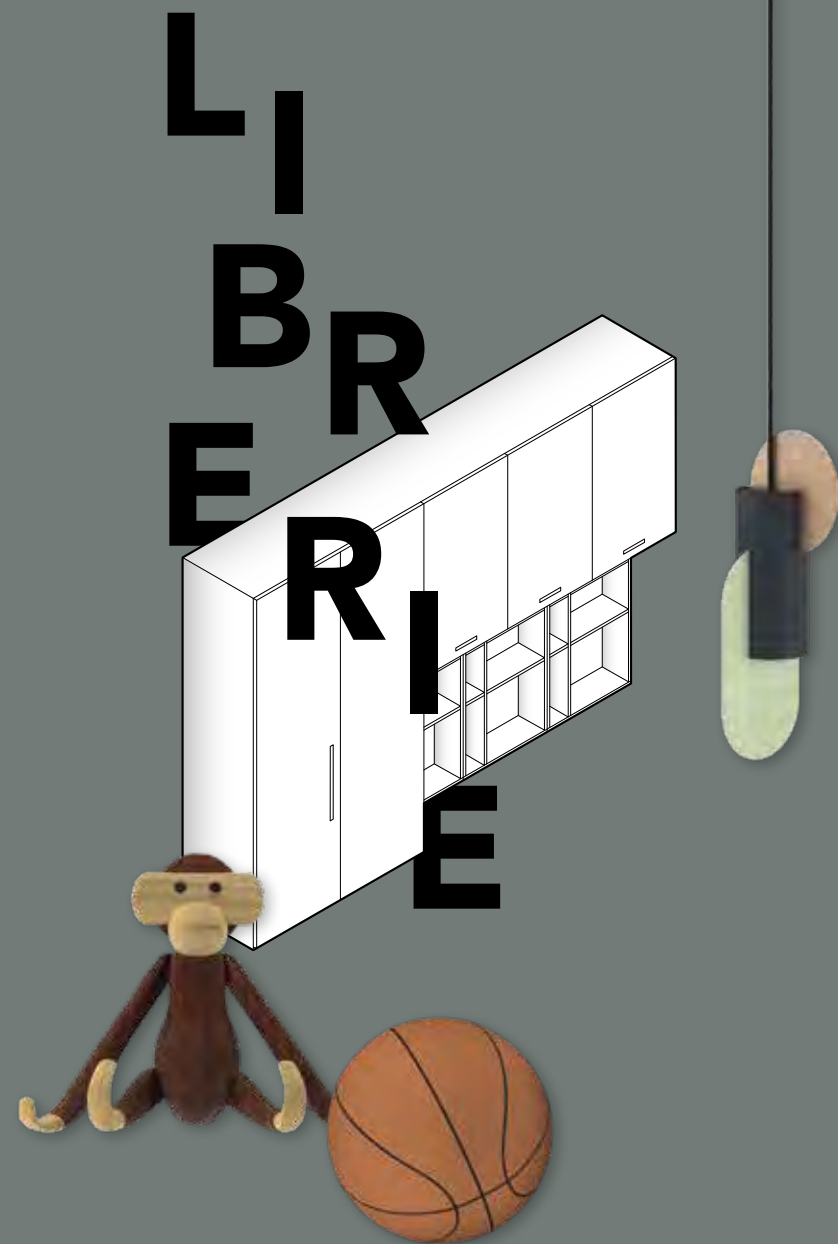

ORIZZONTALE E VERTICALE

— Accostare e
sovrapporre:
moduli con diverse
misure e funzioni,
permettono di realizzare
composizioni per librerie
originali e inseribili
in ogni ambiente.

EN HORIZONTAL AND VERTICAL

Combine units with different sizes and functions to create original bookshelves for every space.

FR HORIZONTAL ET VERTICAL

Combiner des modules avec différentes dimensions et fonctions pour créer des bibliothèques originales et adaptées à tous espaces.







— Composizione 7

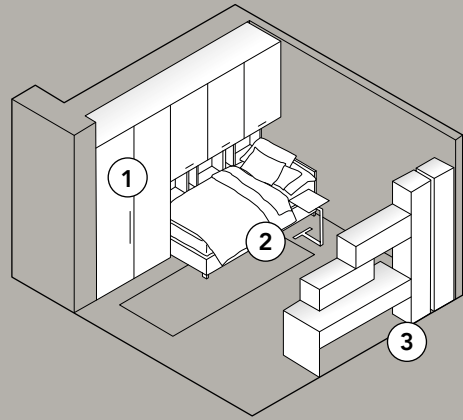

①

IT Armadio FREESTYLE e ponte MULTIBOX integrati in un'unica composizione.
EN FREESTYLE wardrobe and MULTIBOX bridge unit in a single solution.
FR Armoire FREESTYLE et pont MULTIBOX intégrés dans une seule solution.

②

IT Letto SYSTEM FH 28 disponibile con rete fissa, contenitore o con secondo letto estraibile.
EN Bed SYSTEM FH 28 available with fixed base, storage base or with second pull-out slats.
FR Lit SYSTEM FH 28 disponible avec sommier fixe, avec rangement ou avec deuxième lit extractible.

③

IT Area scrittoio con libreria 2.2 e MULTIBOX con anta a ribalta.
EN Desk area with bookshelf 2.2 and MULTIBOX with lift-up door.
FR Espace bureau avec bibliothèque 2.2 et MULTIBOX avec porte relevable.







①

IT Libreria 2.2.
EN Bookshelf 2.2.
FR Bibliothèque 2.2.

②

IT MULTIBOX pensili con anta a ribalta.
EN Hanging units MULTIBOX with lift-up door.
FR MULTIBOX suspendus avec porte relevable.

③

IT Scrivania / Cassettiera su ruote con maniglia M1 / Sgabello con meccanismo di alzata.
EN Desk / Drawers unit on wheels with M1 handle / Stool with seat height adjustment.
FR Bureau / Bloc tiroirs avec poignée M1 / Tabouret avec hauteur réglable.

④

IT Armadio Freestyle con maniglia M1.
EN FREESTYLE wardrobe with M1 handle.
FR Armoire FREESTYLE avec poignée M1.

⑤

IT Letto SYSTEM FH 28 con ruote unidirezionali con freno.
EN Bed SYSTEM FH 28 with unidirectional wheels with brake.
FR Lit SYSTEM FH 28 avec roulettes unidirectionnelles avec frein.

⑥

IT Ponte MULTIBOX con maniglia M1.
EN Bridge unit MULTIBOX with M1 handle.
FR Pont MULTIBOX avec poignée M1.

⑦

IT Comodino UP.
EN UP night table.
FR Chevet UP.

⑧

IT Carta da parati QUADRO nebbia / denim.
EN QUADRO nebbia / denim wallpaper.
FR Papier peint QUADRO nebbia / denim.



STUDIO CREATIVO

— Scrivanie personalizzate
e originali, con versatili
elementi per il contenimento
e trave multifunzionale
Coast to Coast
per appoggiare, illuminare
e appendere.

EN CREATIVE STUDYING

Original and customized desks, created with some versatile units for the storage and the multifunctional Coast to Coast rail to support, light and hang up.

FR ETUDE CREATIVE

Bureaux personnalisés et originaux créés à l'aide de modules pour le rangement et de la barre Coast to Coast pour supporter, éclairer et accrocher.



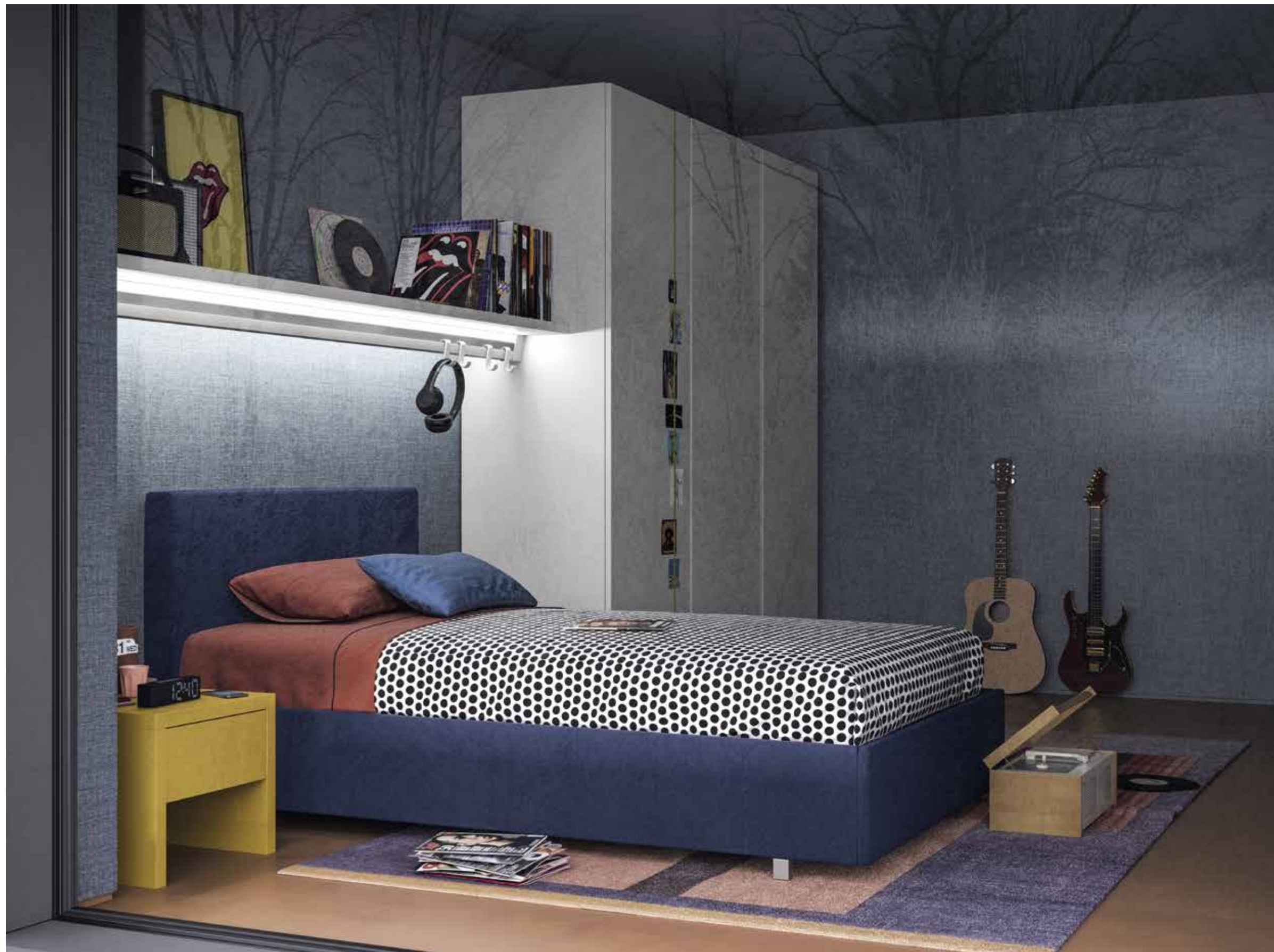

— Composizione 8

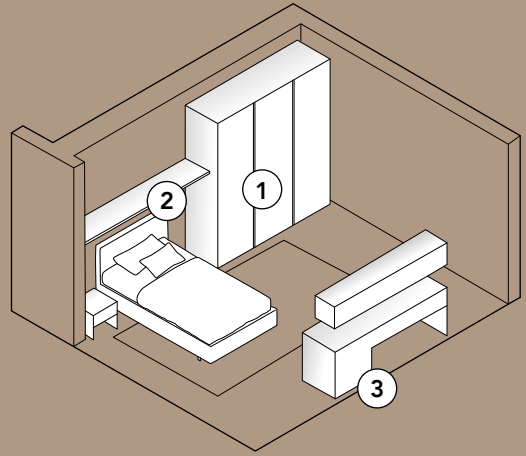

1

IT Armadio FREESTYLE con maniglia M10 in tinta o in contrasto con il colore dell'anta.
EN FREESTYLE wardrobe with M10 handle available with same or different colour of the door.
FR Armoire FREESTYLE avec poignée M10 disponible dans la même couleur que la porte ou en couleur différente.

2

IT Trave COAST TO COAST con mensola, ganci multiuso e illuminazione LED.
EN COAST TO COAST rail with shelf, multifunctional hooks and LED lighting.
FR Barre COAST TO COAST avec étagère, crochets multifonctionnels et éclairage LED.

3

IT Area studio / lavoro con scrittoio e cassetiera con maniglia M7.
EN Study / working area with desk and drawers unit with M7 handle.
FR Espace étude / travail avec bureau et bloc tiroirs avec poignée M7.





①

IT MULTIBOX pensili con anta a ribalta.
EN Hanging units MULTIBOX with lift-up door.
FR MULTIBOX suspendus avec porte relevable.

②

IT Scrivitoio con cassetiera con maniglia M7.
EN Desk with drawers unit with M7 handle.
FR Bureau avec bloc tiroirs avec poignée M7.

③

IT Sedia in polipropilene.
EN Polypropylene chair.
FR Chaise en polypropylène.

④

IT Comodino 35.
EN 35 night table.
FR Chevet 35.

⑤

IT Trave COAST TO COAST con mensola.
EN COAST TO COAST rail with shelf.
FR Barre COAST TO COAST avec étagère.

⑥

IT Letto SYSTEM FH 28.
EN Bed SYSTEM FH 28.
FR Lit SYSTEM FH 28.

⑦

IT Armadio FREESTYLE con maniglia M10.
EN FREESTYLE wardrobe with M10 handle.
FR Armoire FREESTYLE avec poignée M10.

⑧

IT Carta da parati QUADRO argilla/cipria.
EN QUADRO argilla/cipria wallpaper.
FR Papier peint QUADRO argilla/cipria.



FUNZIONALITÀ SEMPRE DI MODA

— Armadi che abbinano uno stile sempre attuale e delle soluzioni sempre funzionali: progettati e realizzati per durare a lungo nel tempo.

EN FASHIONABLE FUNCTIONALITY
Wardrobes that combine a contemporary style with functional solutions.
Products designed and realized to last a long time.

FR FONCTIONNALITE TOUJOURS A LA MODE
Armoires qui joignent un style contemporain toujours avec des solutions fonctionnelles. Des produits conçus et réalisés pour durer dans le temps.



— Composizione 9

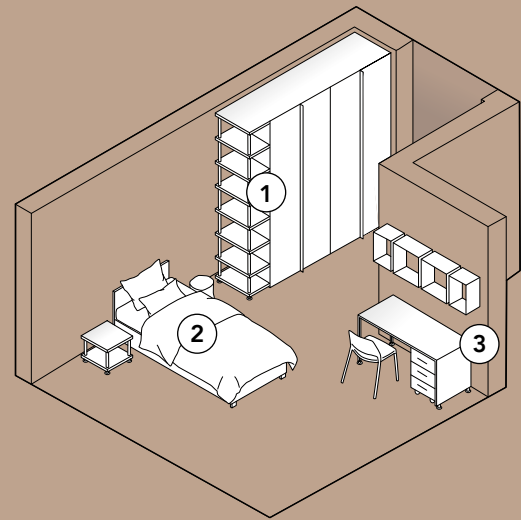

①

IT Armadio FREESTYLE con libreria terminale RIBE.
EN FREESTYLE wardrobe with RIBE final bookshelf.
FR Armoire FREESTYLE avec bibliothèque finale RIBE.

②

IT Letto SYSTEM FH 28 con rete fissa o contenitore, disponibile con materasso di diverse misure (80 / 90 / 100 / 120 x 200 cm).
EN Bed SYSTEM FH 28 with fixed base or storage base, available for mattress of different sizes (80 / 90 / 100 / 120 x 200 cm).
FR Lit SYSTEM FH 28 avec sommier fixe ou avec rangement, disponible pour matelas de différentes dimensions (80 / 90 / 100 / 120 x 200 cm).

③

IT Scrivania con moduli INFINITY senza schienale.
EN Desk with INFINITY units without back.
FR Bureau avec modules INFINITY sans dos.



— Composizione 9



①

IT INFINITY pensili.
EN Hanging units INFINITY.
FR INFINITY suspendus.

②

IT Sedia in polipropilene.
EN Polypropylene chair.
FR Chaise en polypropylène.

③

IT Scrivania e cassettiera RIBE con maniglia M18.
EN RIBE desk and drawers unit with M18 handle.
FR Bureau et bloc tiroirs RIBE avec poignée M18.

④

IT Comodino RIBE.
EN RIBE night table.
FR Chevet RIBE.

⑤

IT Letto RIBE SYSTEM FH 28.
EN RIBE bed SYSTEM FH 28.
FR Lit RIBE SYSTEM FH 28.

⑥

IT Libreria terminale RIBE.
EN RIBE final bookshelf.
FR Bibliothèque finale RIBE.

⑦

IT Armadio FREESTYLE con maniglia M8.
EN FREESTYLE wardrobe with M8 handle.
FR Armoire FREESTYLE avec poignée M8.

⑧

IT Carta da parati TUTTIFRUTTI cipria.
EN TUTTIFRUTTI cipria wallpaper.
FR Papier peint TUTTIFRUTTI cipria.

— Index



— Ribe

EN Ribe
FR Ribe

Page. 104



— Ponte Coast to Coast

EN Coast to Coast bridge unit
FR Pont Coast to Coast

Page. 106



— Letti

EN Beds
FR Lits

Page. 130



— Comodini

EN Night tables
FR Chevets

Page. 136

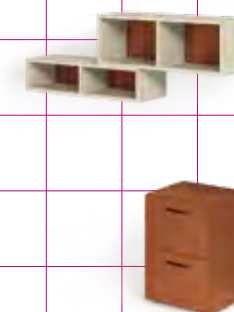

— Multibox / Infinity

EN Multibox / Infinity
FR Multibox / Infinity

Page. 144



— Maniglie

EN Handles
FR Poignées

Page. 138



— Finiture nobilitato*

EN Melamine finishes
FR Finitions mélamine

Page. 108



— Tessuti*

EN Fabrics
FR Tissus

Page. 110

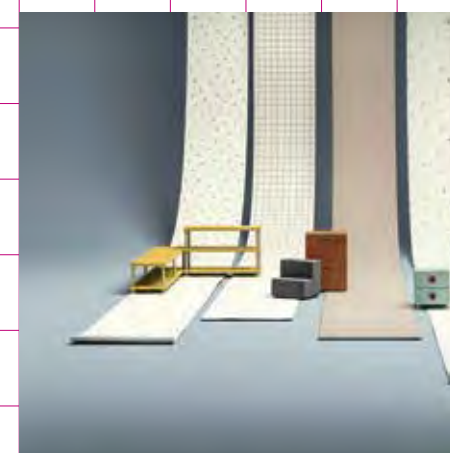

— Carte da parati*

EN Wallpapers
FR Papiers peints

Page. 118



— Scrivanie

EN Desks
FR Bureaux

Page. 148



— Sedie e pouf

EN Chairs and pouf
FR Chaises et pouf

Page. 150

*

IT Nell'impossibilità di riprodurre fedelmente colori, finiture e pattern, vi invitiamo a consultare i relativi campioni.

EN For a correct evaluation of colours, finishes and patterns, we suggest you to consult physical samples.

FR Pour une évaluation correcte des couleurs, finitions et dessins nous vous conseillons de faire référence aux échantillons physiques.

Ribe

Piani orizzontali con diverse misure e finiture, sostenuti da masselli di acero torniti. Ecco Ribe: sistema flessibile per un progetto capace di adeguarsi a spazi e necessità diverse.



EN RIBE Shelves with different sizes and finishes with turned maple wood supports. This is Ribe: a flexible project able to suit different spaces and needs.

FR RIBE Etagères de différentes dimensions et finitions avec des supports en bois d'érable tourné. Voici Ribe: un projet flexible capable de s'adapter à différents espaces et besoins.

Ponte Coast To Coast

Una struttura di base attrezzata con trave Coast to Coast multifunzionale, luce LED integrata e predisposta per agganciare mensole, appendiabiti e ganci. Sopra questo portale, si possono appoggiare moduli libreria e contenitori con misure e colori personalizzabili, anche in tempi diversi per adeguare la composizione a diverse età ed esigenze.



EN COAST TO COAST BRIDGE UNIT A simple structure accessorized with the multifunctional Coast to Coast rail, with LED light, offering the possibility to fix shelves, coat hangers and hooks. Above this structure, over the years, it is possible to install bookshelves and storage units with customized sizes and finishes, to adapt the solution to different ages and needs.

FR PONT COAST TO COAST Une simple structure équipée de barre multifonctionnelle Coast to Coast, avec LED, qui donne la possibilité d'attacher des étagères, des portemanteaux et des crochets. Dans le temps, c'est possible d'intégrer la structure avec des bibliothèques et des armoires avec finitions et dimensions personnalisées, afin de rendre la composition adaptée à différentes âges et besoins.

— Moodboard



- 1 Cipria
- 2 Argilla
- 3 Rovere Rift
- 4 6 - 16 cat. 6
- 5 Tuttifrutti Cipria
- 6 Granata
- 7 Oliva
- 8 Zafferano

— Finiture nobilitato

EN Melamine finishes / FR Finitions mélamine



- BIANCO MILANO
- ERBA
- LINO
- CANAPA
- GRIS WOOD
- ROVERE RIFT

— Moodboard

— Tessuti

EN Fabrics / FR Tissus



- 1 3 - 33 cat. 3
- 2 Glacier
- 3 Meteo Bianco
- 4 2 - 23 cat. 2
- 5 6 - 5 cat. 6
- 6 Denim
- 7 4 - 37 cat. 4
- 8 3 - 20 cat. 3
- 9 Rovere Rift

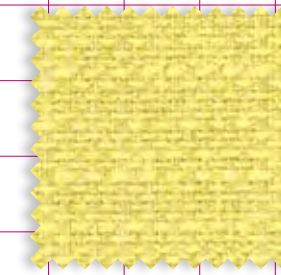

2 - 16
cat. 2

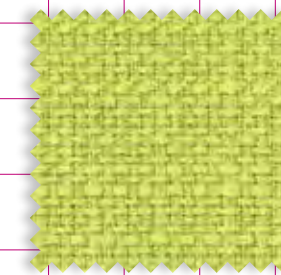

2 - 17
cat. 2

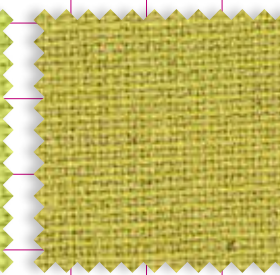

3 - 29
cat. 3

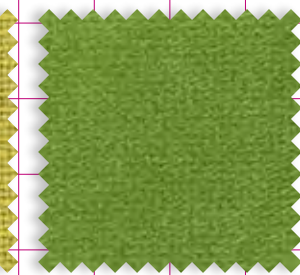

4 - 22
cat. 4

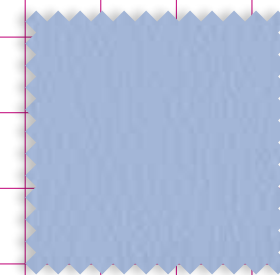

1 - 26
cat. 1

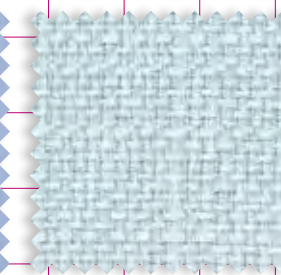

2 - 23
cat. 2

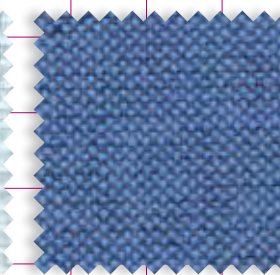

3 - 33
cat. 3

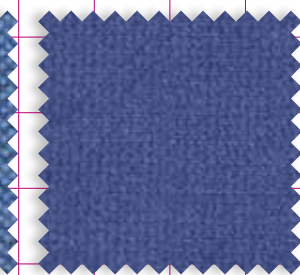

4 - 37
cat. 4

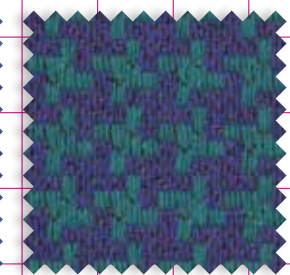

6 - 5
cat. 6

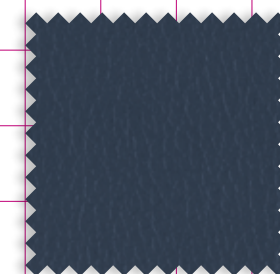

1 - 29
cat. 1

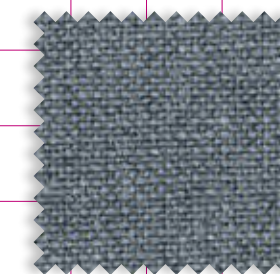

3 - 20
cat. 3



4 - 36
cat. 4

— Tessuti

EN Fabrics / FR Tissus

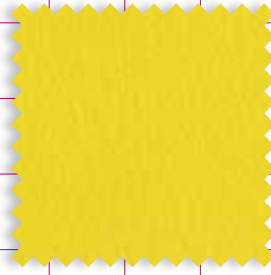

1 - 7
cat. 1

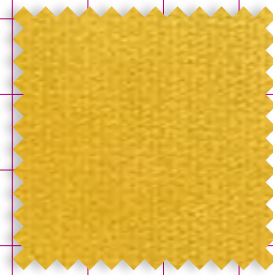

4 - 8
cat. 4

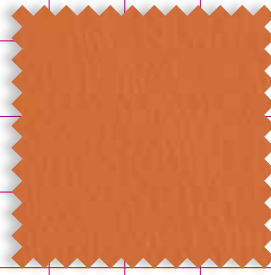

1 - 6
cat. 1

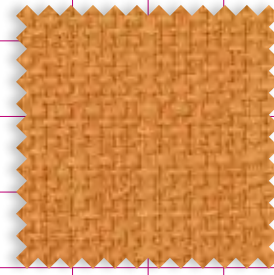

2 - 6
cat. 2

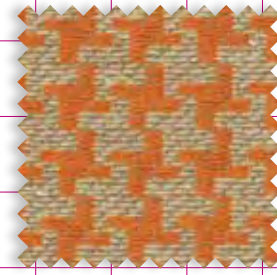

6 - 16
cat. 6



1 - 8
cat. 1

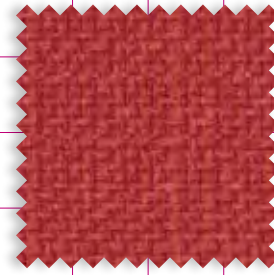

2 - 8
cat. 2



4 - 9
cat. 4

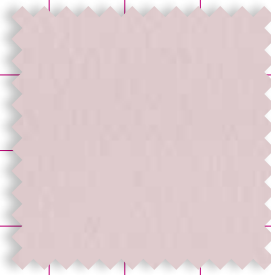

1 - 10
cat. 1

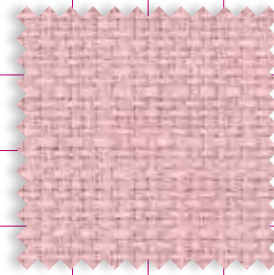

2 - 13
cat. 2



4 - 47
cat. 4

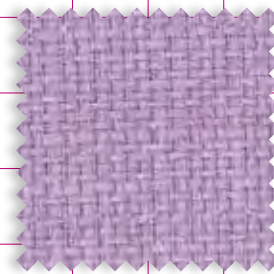

2 - 15
cat. 2



6 - 13
cat. 6

— Moodboard



- 1 Riga argilla / nebbia
- 2 Cipria
- 3 Zafferano
- 4 2 - 8 cat. 2
- 5 Bianco
- 6 4 - 9 cat. 4
- 7 6 - 16 cat. 6
- 8 Quadro bianco / granata
- 9 Granata

— Moodboard



- 1 1 - 35 cat. 1
- 2 Gris Wood
- 3 Avorio
- 4 Seppia
- 5 Riga nebbia / seppia
- 6 3 - 14 cat. 3
- 7 5 - 105 cat. 5
- 8 Bianco Milano

— Tessuti

EN Fabrics / FR Tissus

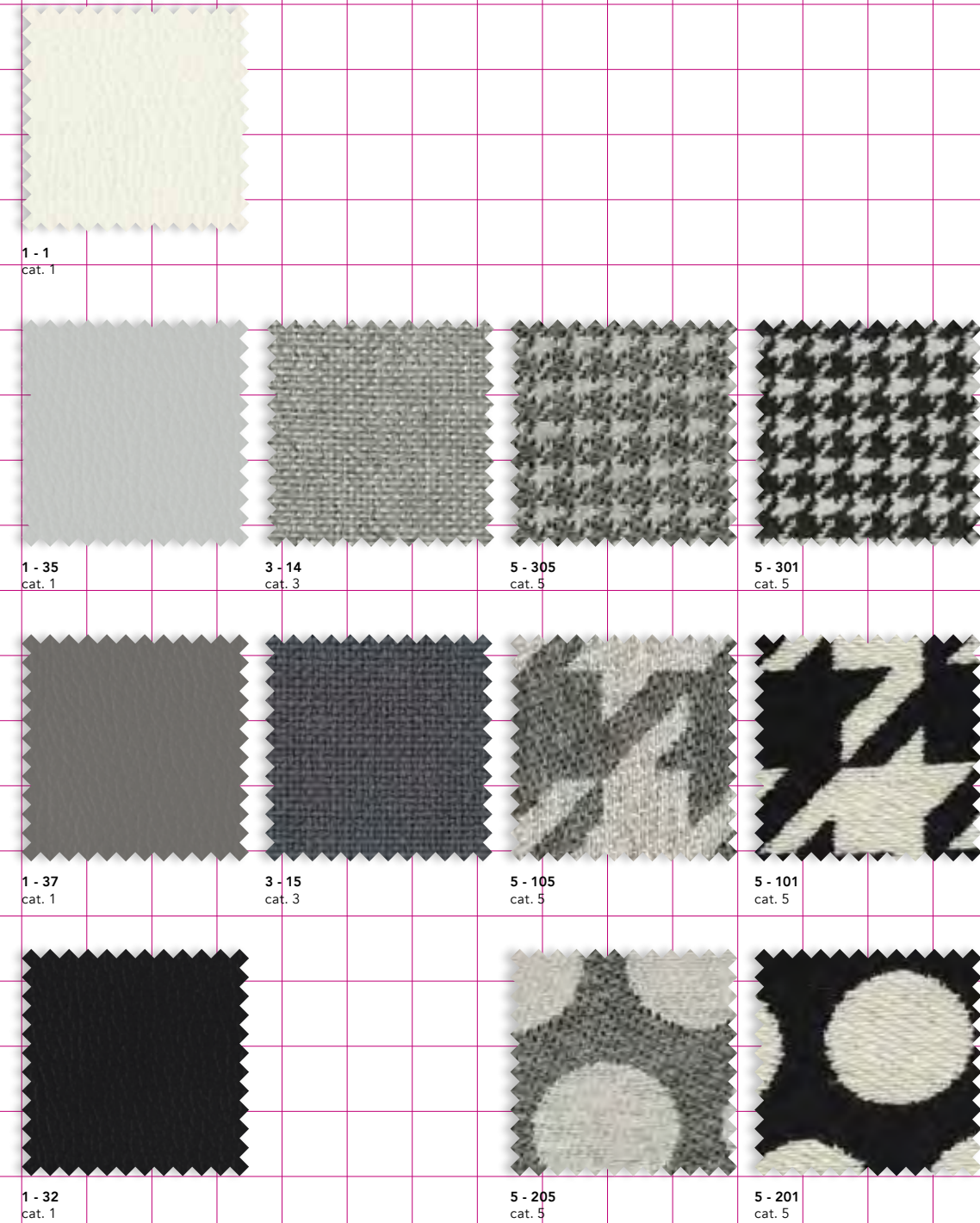

- 1 - 1 cat. 1
- 1 - 35 cat. 1
- 3 - 14 cat. 3
- 5 - 305 cat. 5
- 5 - 301 cat. 5
- 1 - 37 cat. 1
- 3 - 15 cat. 3
- 5 - 105 cat. 5
- 5 - 101 cat. 5
- 1 - 32 cat. 1
- 5 - 205 cat. 5
- 5 - 201 cat. 5

— Tessuti

EN Fabrics / FR Tissus

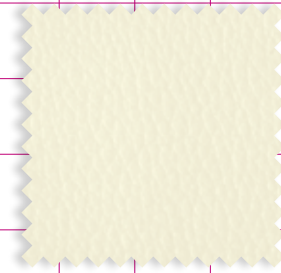

1 - 2
cat. 1

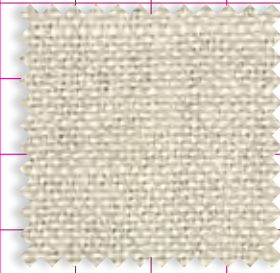

3 - 1
cat. 3

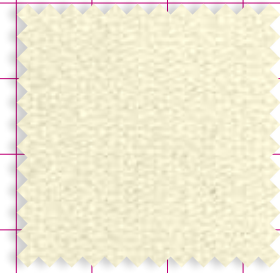

4 - 1
cat. 4

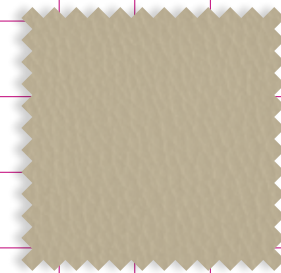

1 - 17
cat. 1

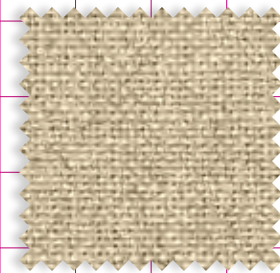

3 - 9
cat. 3

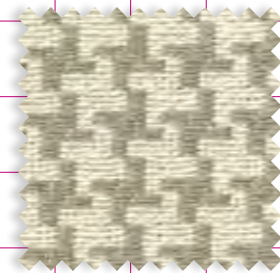

6 - 2
cat. 6

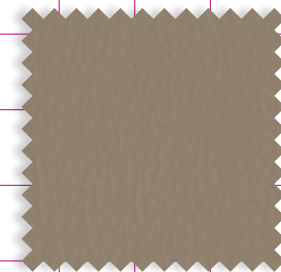

1 - 22
cat. 1

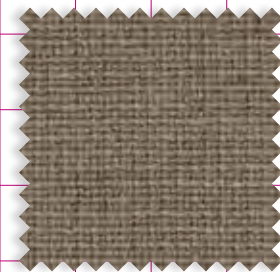

3 - 7
cat. 3



5 - 103
cat. 5

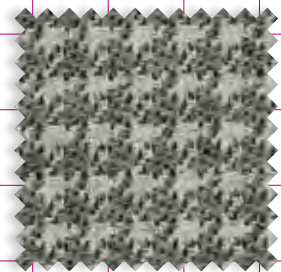

5 - 303
cat. 5

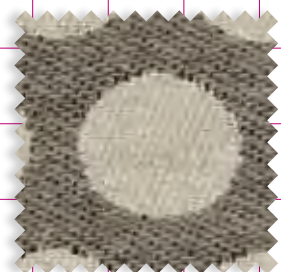

5 - 203
cat. 5

— Moodboard



- 1 Meteo bianco
- 2 Rovere Rift
- 3 1 - 2 cat. 1
- 4 Creta
- 5 Pied de poule zafferano
- 6 3 - 9 cat. 3
- 7 5 - 103 cat. 5
- 8 Canapa
- 9 Lino



Carte da parati

Grafiche e colori
che aggiungono un'ulteriore
dimensione visiva allo spazio,
permettendo di trasformarlo
facilmente nel tempo,
in sintonia con le nuove
tendenze e
con l'evoluzione
dei gusti personali.

EN WALLPAPER Patterns and colours which add a new optical dimension to the space and allow to transform it easily over time, following the latest trends and the personal tastes evolution.

FR PAPIERS PEINTS Dessins et couleurs qui ajoutent une dimension visuelle supplémentaire à l'espace et permettent de le transformer facilement dans le temps, suivant les dernières tendances et l'évolution des goûts personnels.

— Moodboard



- 1 Gris Wood
- 2 Riga argilla / nebbia
- 3 5- 203 cat. 5
- 4 Granata
- 5 Riga granata / argilla

— Carta da parati Riga

EN Riga wallpaper / FR Papiers peints Riga

IT Riferimento finiture nobilitato / EN Melamine finishes reference / FR Référence finitions mélamine



CIPRIA ARGILLA GRANATA ZAFFERANO LILLA



CIPRIA / ARGILLA ARGILLA / NEBBIA GRANATA / ARGILLA ZAFFERANO / NEBBIA

IT Riferimento finiture nobilitato / EN Melamine finishes reference / FR Référence finitions mélamine



OLIVA GLACIER DENIM LAVANDA

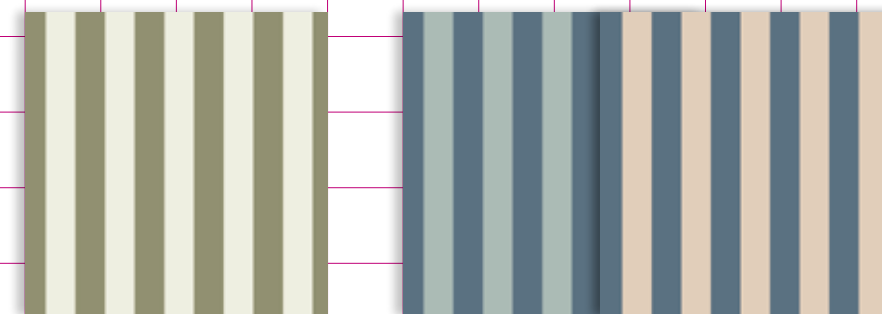

OLIVA / NEBBIA GLACIER / DENIM DENIM / CIPRIA

IT Riferimento finiture nobilitato / EN Melamine finishes reference / FR Référence finitions mélamine

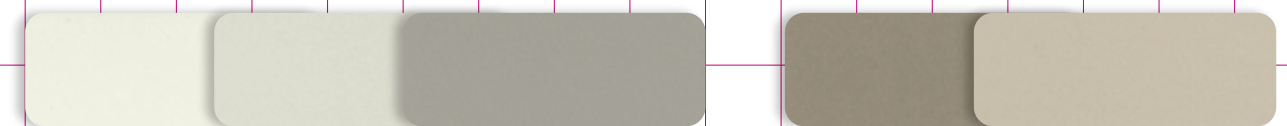

BIANCO NEBBIA SEPPIA CRETA AVORIO

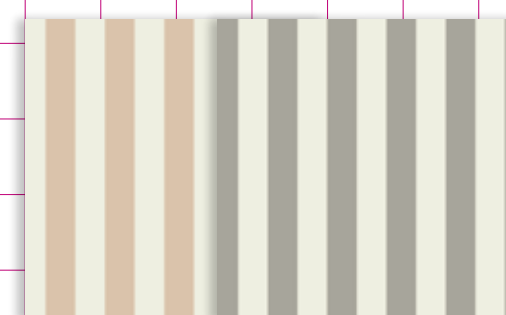

BIANCO / CIPRIA NEBBIA / SEPPIA

— Carta da parati Pied de poule

EN Pied de poule wallpaper / FR Papiers peints Pied de poule

IT Riferimento finiture nobilitato / EN Melamine finishes reference / FR Référence finitions mélamine



CIPRIA ARGILLA GRANATA ZAFFERANO



CIPRIA ARGILLA GRANATA ZAFFERANO

IT Riferimento finiture nobilitato / EN Melamine finishes reference / FR Référence finitions mélamine



OLIVA GLACIER DENIM

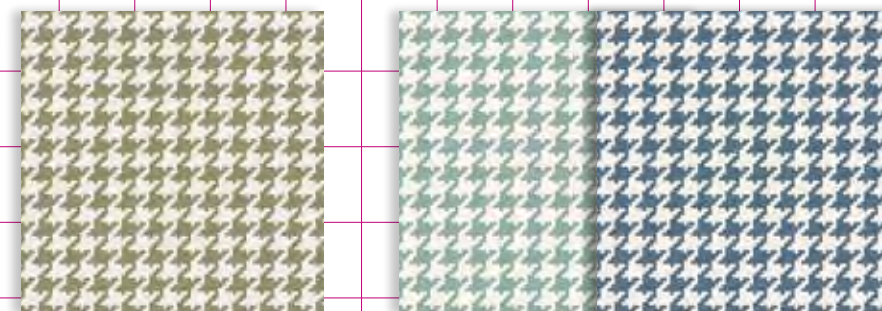

OLIVA GLACIER DENIM

IT Riferimento finiture nobilitato / EN Melamine finishes reference / FR Référence finitions mélamine

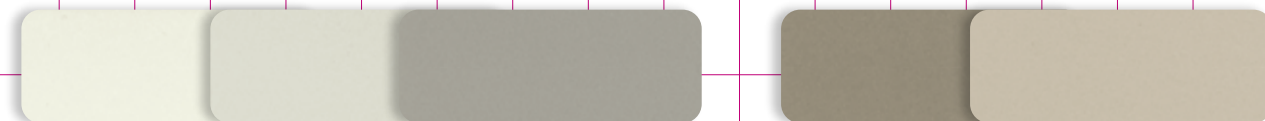

BIANCO NEBBIA SEPPIA CRETA AVORIO

— Moodboard

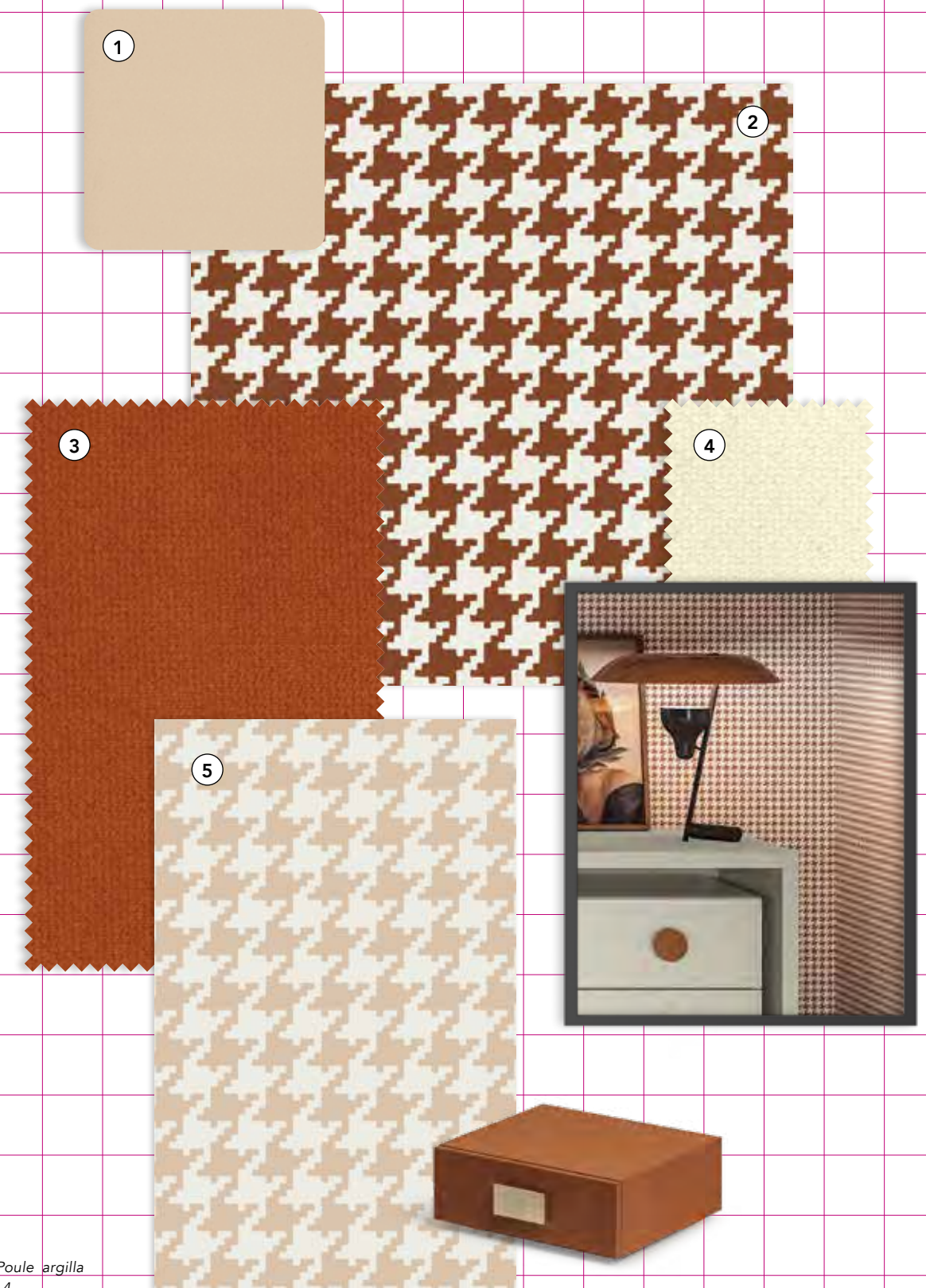

- 1 Cipria
- 2 Pied de Poule argilla
- 3 4 - 9 cat. 4
- 4 4 - 1 cat. 4
- 5 Pied de Poule cipria

— Moodboard

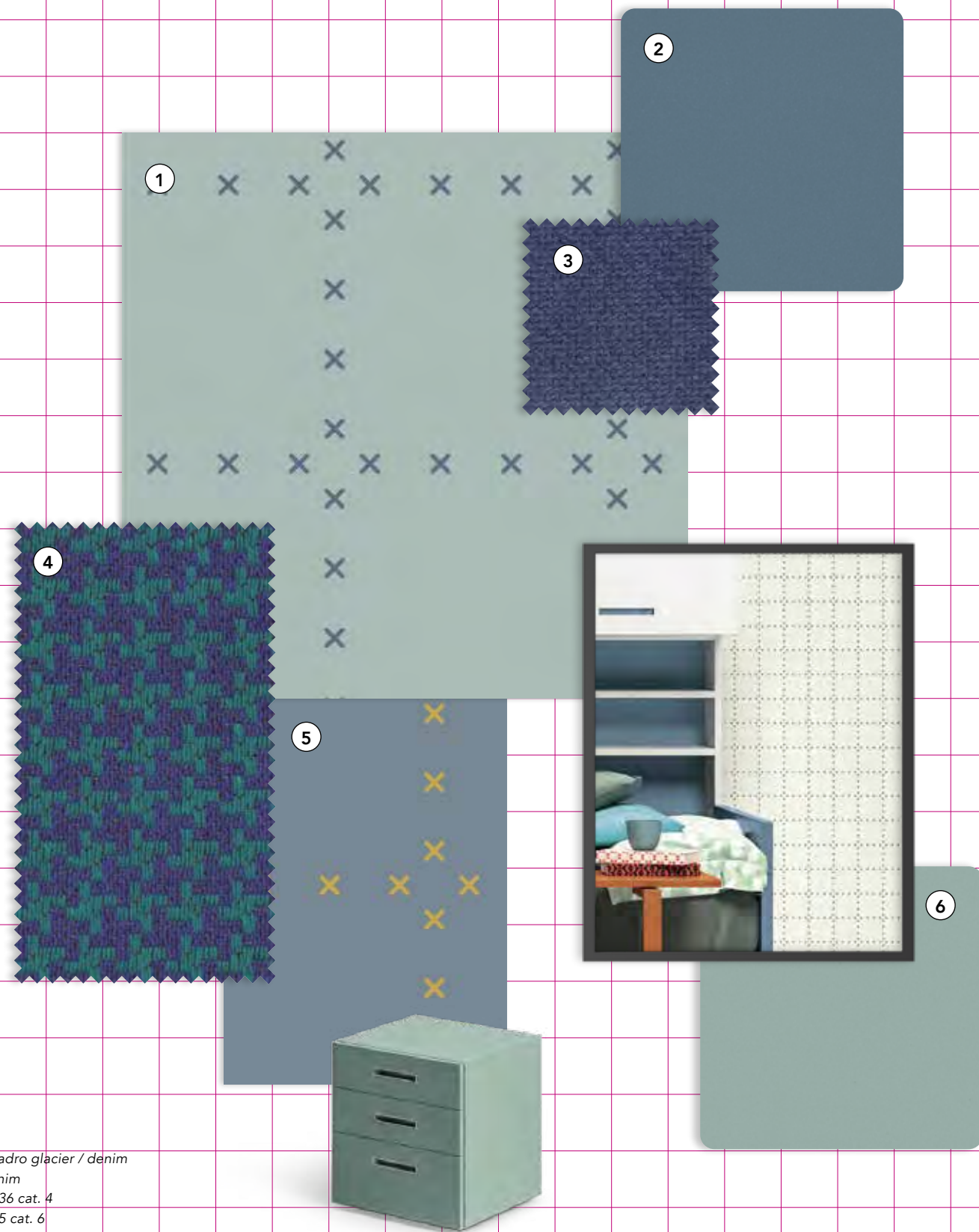

- 1 Quadro glacier / denim
- 2 Denim
- 3 4 - 36 cat. 4
- 4 6 - 5 cat. 6
- 5 Quadro denim / zafferano
- 6 Glacier

— Carta da parati Quadro

EN Quadro wallpaper / FR Papiers peints Quadro

IT Riferimento finiture nobilitato / EN Melamine finishes reference / FR Référence finitions mélamine



CIPRIA ARGILLA GRANATA ZAFFERANO LILLA



CIPRIA / ARGILLA ARGILLA / CIPRIA GRANATA / CIPRIA ZAFFERANO / DENIM

IT Riferimento finiture nobilitato / EN Melamine finishes reference / FR Référence finitions mélamine



OLIVA GLACIER DENIM LAVANDA

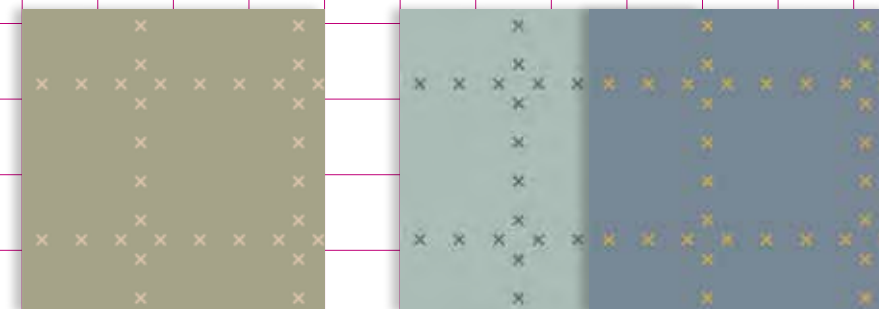

OLIVA / CIPRIA GLACIER / DENIM DENIM / ZAFFERANO

IT Riferimento finiture nobilitato / EN Melamine finishes reference / FR Référence finitions mélamine



BIANCO NEBBIA SEPPIA CRETA AVORIO

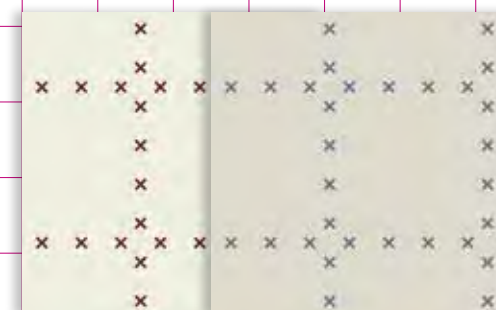

BIANCO / GRANATA NEBBIA / DENIM

— Carta da parati Tuttifrutti

EN Tuttifrutti wallpaper / FR Papiers peints Tuttifrutti

IT Riferimento finiture nobilitato / EN Melamine finishes reference / FR Référence finitions mélamine



CIPRIA ARGILLA GRANATA ZAFFERANO LILLA



CIPRIA ARGILLA GRANATA ZAFFERANO

IT Riferimento finiture nobilitato / EN Melamine finishes reference / FR Référence finitions mélamine



OLIVA GLACIER DENIM LAVANDA

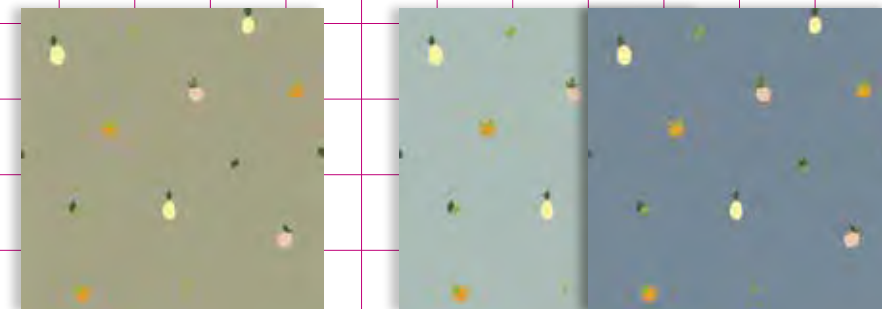

OLIVA GLACIER DENIM

IT Riferimento finiture nobilitato / EN Melamine finishes reference / FR Référence finitions mélamine



BIANCO NEBBIA SEPPIA CRETA AVORIO

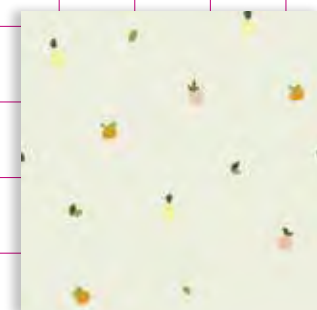

BIANCO

— Moodboard

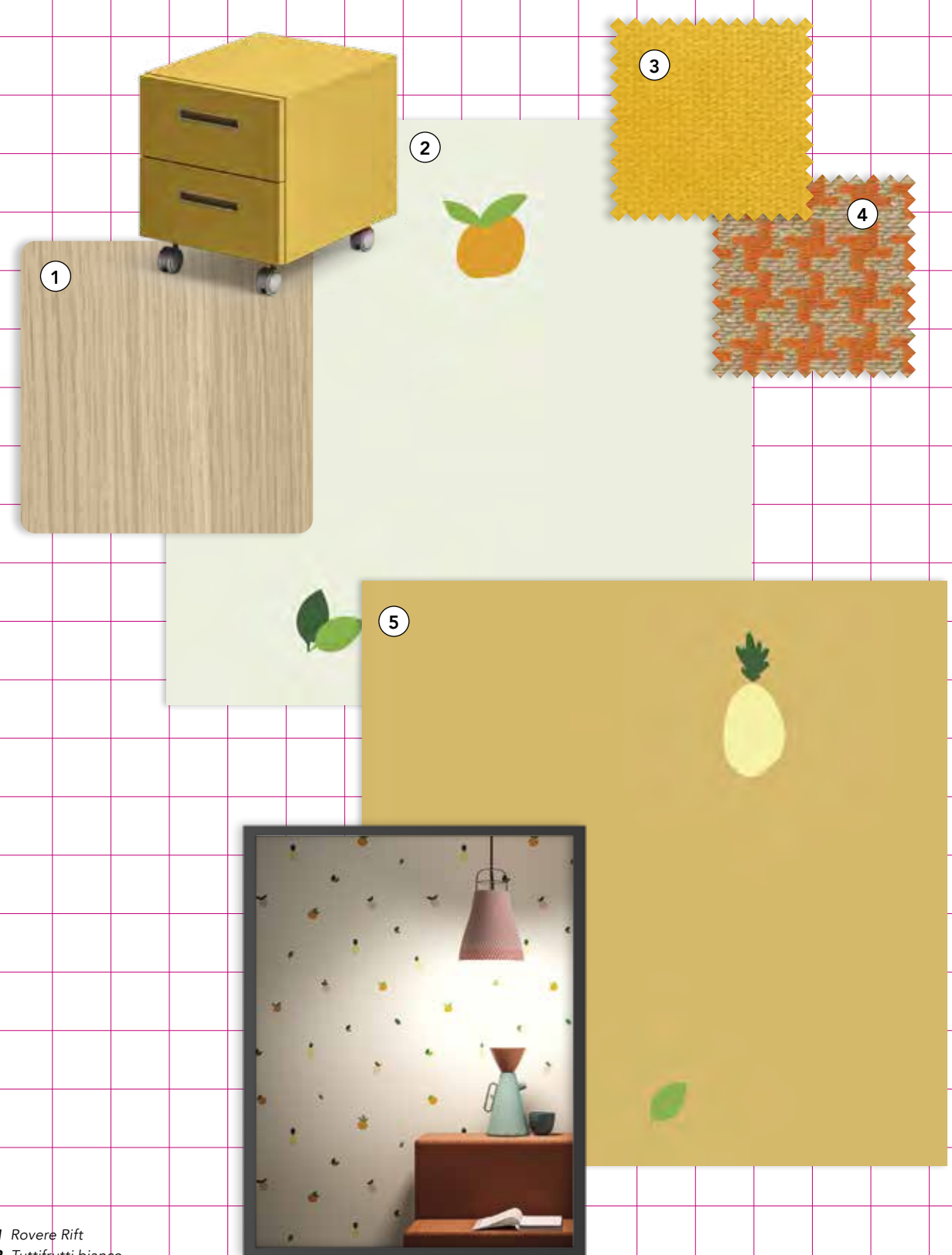

- 1 Roverè Rift
- 2 Tuttifrutti bianco
- 3 4 - 8 cat. 4
- 4 6 - 16 cat. 6
- 5 Tuttifrutti zafferano

— Moodboard

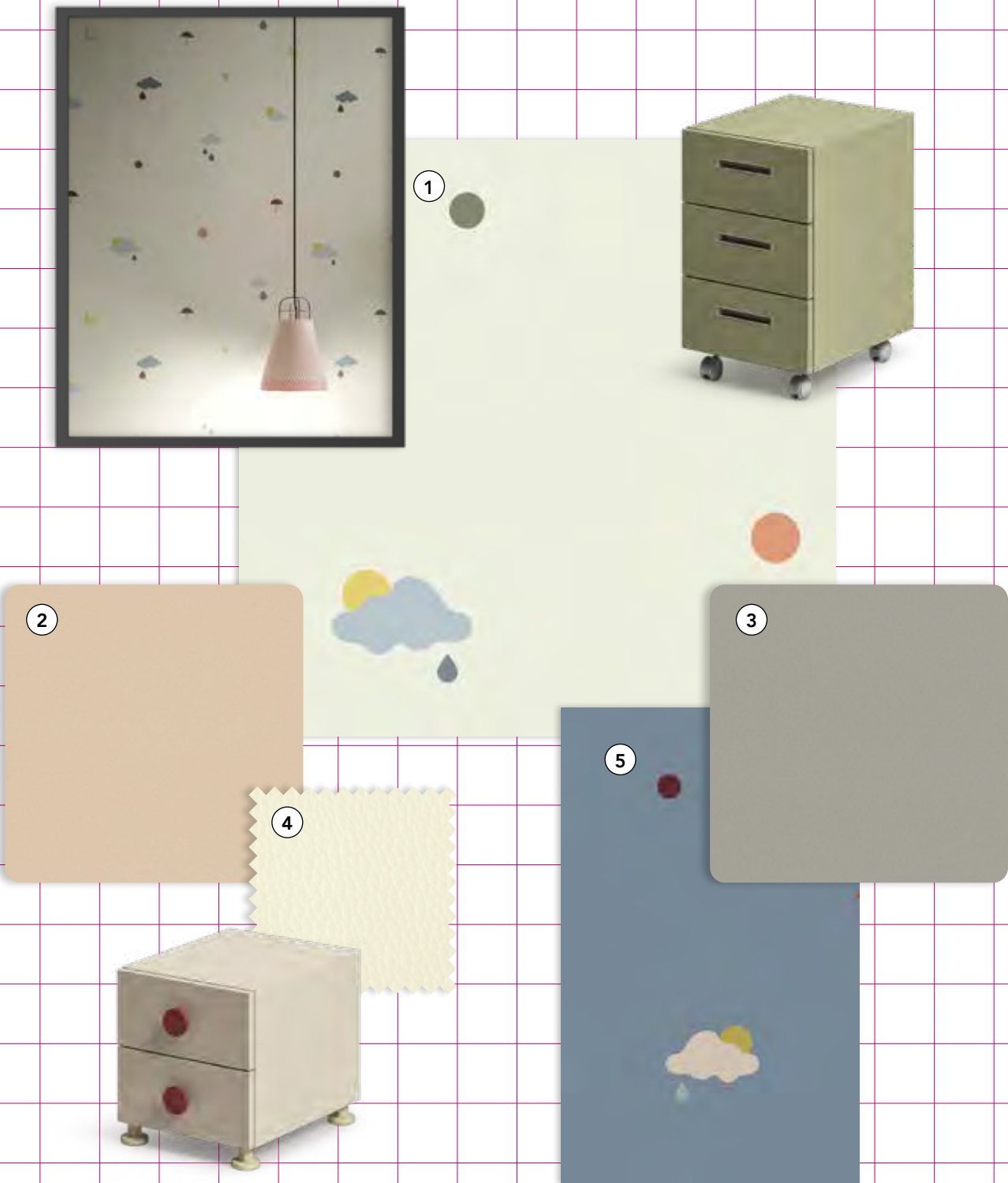

- 1 Meteo bianco
- 2 Cipria
- 3 Seppia
- 4 1 - 1 cat. 1
- 5 Meteo denim

— Carta da parati Meteo

EN Meteo wallpaper / FR Papiers peints Meteo

IT Riferimento finiture nobilitato / EN Melamine finishes reference / FR Référence finitions mélamine



CIPRIA

ARGILLA

GRANATA

ZAFFERANO

LILLA

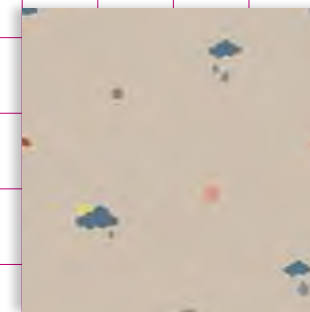

CIPRIA



GRANATA

ZAFFERANO

IT Riferimento finiture nobilitato / EN Melamine finishes reference / FR Référence finitions mélamine

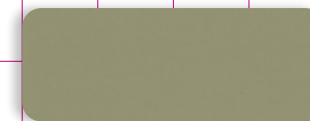

OLIVA



GLACIER

DENIM

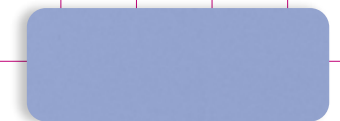

LAVANDA



OLIVA

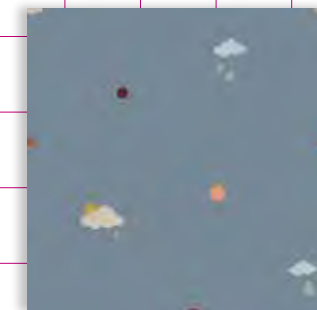

DENIM

IT Riferimento finiture nobilitato / EN Melamine finishes reference / FR Référence finitions mélamine

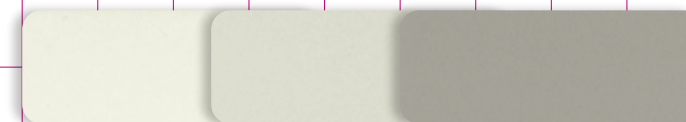

BIANCO

NEBBIA

SEPPIA

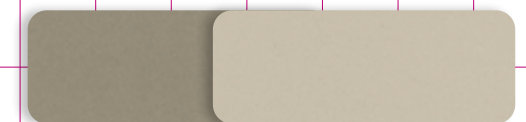

CRETA

AVORIO

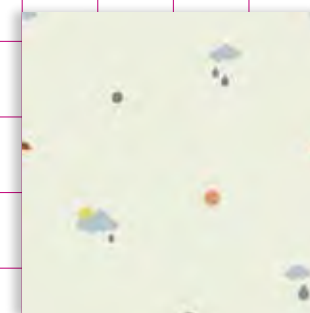

BIANCO



SEPPIA

ERBA

— Caratteristiche del sistema letti

EN Features of the beds system
FR Caractéristiques du système des



— System FH 10



IT Letto System FH 10
EN Bed System FH 10
FR Lit System FH 10

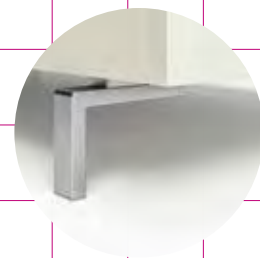

IT Piede metallo H 14,5 cm
EN Metal foot H 14,5 cm
FR Pied en métal H 14,5 cm

IT Piede RIBE H 14,5 cm
EN RIBE foot H 14,5 cm
FR Pied RIBE H 14,5 cm

IT Ruota piroettante con freno
EN Pivoting wheel with brake
FR Roulette pivotante avec frein

— System FH 19



IT Letto System FH 19
EN Bed System FH 19
FR Lit System FH 19

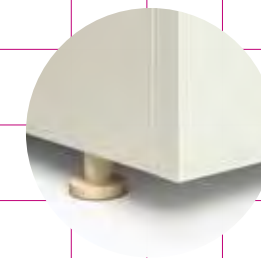
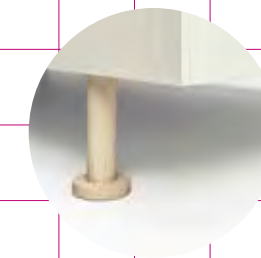
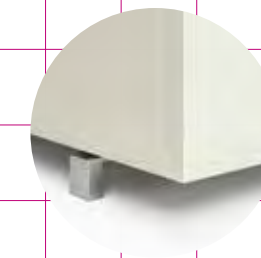
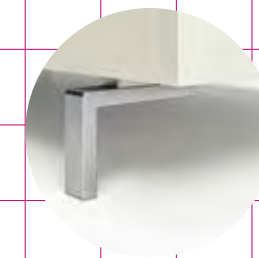
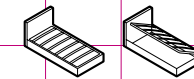

IT Piede metallo H 14,5 cm
EN Metal foot H 14,5 cm
FR Pied en métal H 14,5 cm

IT Piede metallo H 5,5 cm
EN Metal foot H 5,5 cm
FR Pied en métal H 5,5 cm

IT Piede RIBE H 14,5 cm
EN RIBE foot H 14,5 cm
FR Pied RIBE H 14,5 cm

IT Piede RIBE H 5,5 cm
EN RIBE foot H 5,5 cm
FR Pied RIBE H 5,5 cm

IT Ruota piroettante con freno
EN Pivoting wheel with brake
FR Roulette pivotante avec frein

— System FH 28



IT Letto System FH 28
EN Bed System FH 28
FR Lit System FH 28

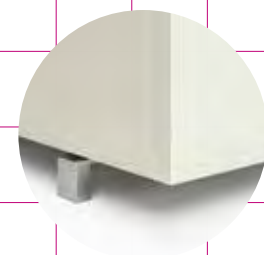
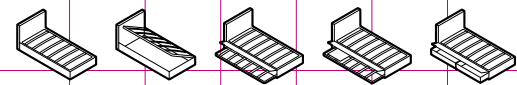

IT Piede metallo H 5,5 cm
EN Metal foot H 5,5 cm
FR Pied en métal H 5,5 cm

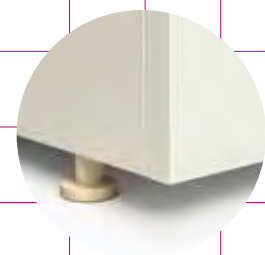

IT Piede RIBE H 5,5 cm
EN RIBE foot H 5,5 cm
FR Pied RIBE H 5,5 cm



IT Ruota unidirezionale con freno
EN Unidirectional wheel with brake
FR Roulette unidirectionnelle avec frein

— Letto a castello

EN Bunk bed / **FR** Lit superposés



IT Letto a castello
EN Bunk beds
FR Lits superposés

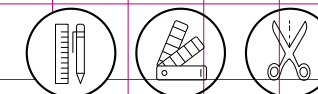

— Legenda

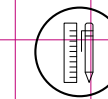

IT Personalizzazione
EN Customization
FR Personnalisation

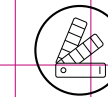

IT Finiture
EN Finishes
FR Finitions

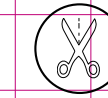

IT Su misura
EN Custom-made
FR Sur-mesure

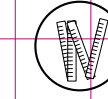

IT Larghezze
EN Widths
FR Largeurs

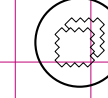

IT Tessuti
EN Fabrics
FR Tissus

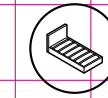

IT Rete fissa
EN Fixed slats
FR Sommier fixe

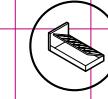

IT Letto con contenitore
EN Bed with storage base
FR Lit avec rangement

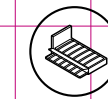

IT Letto con fascia apribile, rete estraibile
EN Bed with liftable frame, pull-out slats
FR Lit avec bande ouvrante, sommier extractible

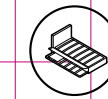

IT Letto con fascia apribile, rete estraibile con testata
EN Bed with liftable frame, pull-out slats with headboard
FR Lit avec bande ouvrante, sommier extractible avec tête

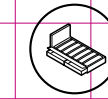

IT Letto con fascia apribile, cassettoni su ruote
EN Bed with liftable frame, big drawers on wheels
FR Lit avec bande ouvrante, grands tiroirs sur roulettes

— Comodini

EN Night tables / **FR** Chevets



IT Comodino RIBE.
EN RIBE night table.
FR Chevet RIBE.



IT Comodino RIBE.
EN RIBE night table.
FR Chevet RIBE.



IT Comodino RIBE.
EN RIBE night table.
FR Chevet RIBE.



IT Comodino UP.
EN UP night table.
FR Chevet UP.



IT Comodino 35.
EN 35 night table.
FR Chevet 35.

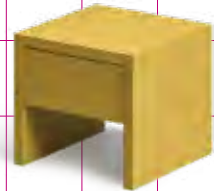

IT Comodino 35.
EN 35 night table.
FR Chevet 35.



IT Comodino MULTIBOX.
EN MULTIBOX night table.
FR Chevet MULTIBOX.



IT Comodino MULTIBOX.
EN MULTIBOX night table.
FR Chevet MULTIBOX.



IT Comodino su ruote.
EN Night table on wheels.
FR Chevet avec roulettes.



IT Comodino su ruote.
EN Night table on wheels.
FR Chevet avec roulettes.



IT Comodino con vassoio.
EN Night table with tray.
FR Chevet avec plateau.

— Maniglie

EN Handles / FR Poignées

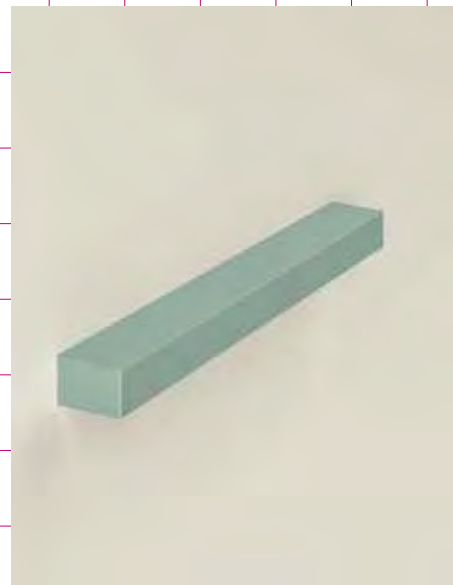

IT Maniglia M14.
EN M14 handle.
FR Poignée M14.

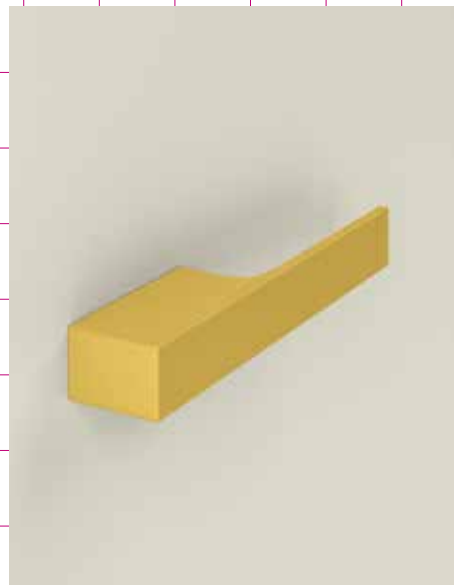

IT Maniglia M4.
EN M4 handle.
FR Poignée M4.

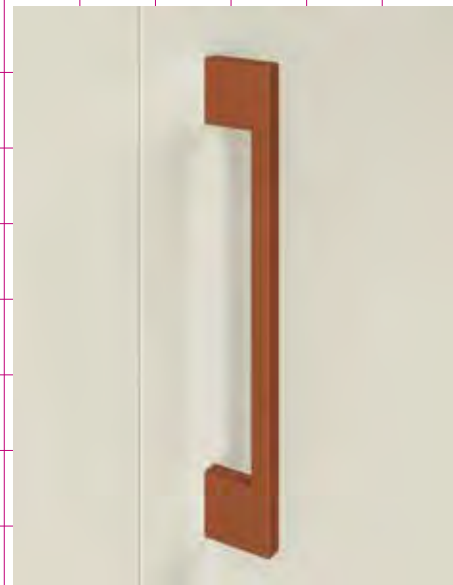

IT Maniglia M15.
EN M15 handle.
FR Poignée M15.

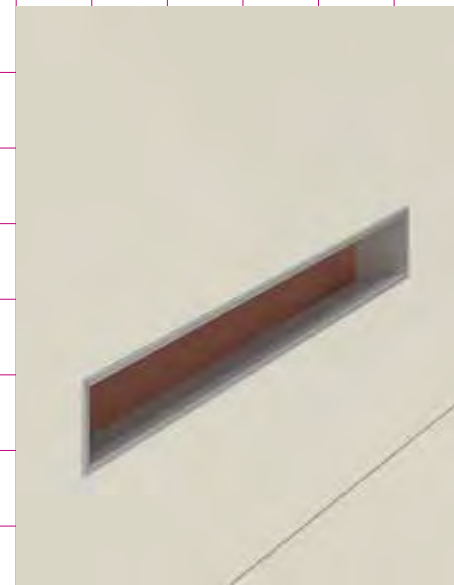

IT Maniglia M1S.
EN M1S handle.
FR Poignée M1S.



IT Maniglia M8.
EN M8 handle.
FR Poignée M8.

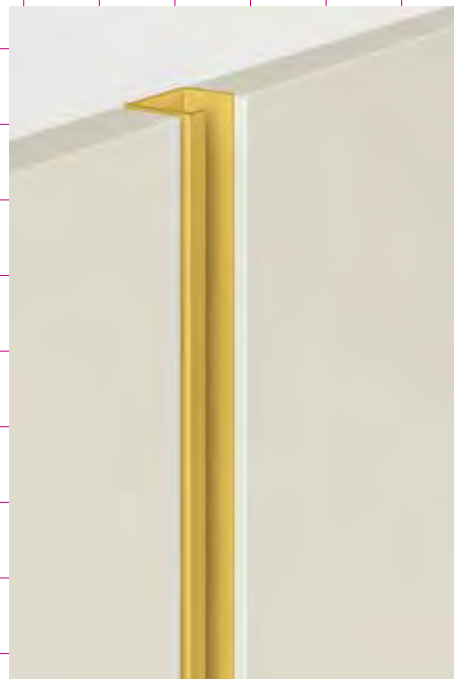

IT Maniglia M10.
EN M10 handle.
FR Poignée M10.

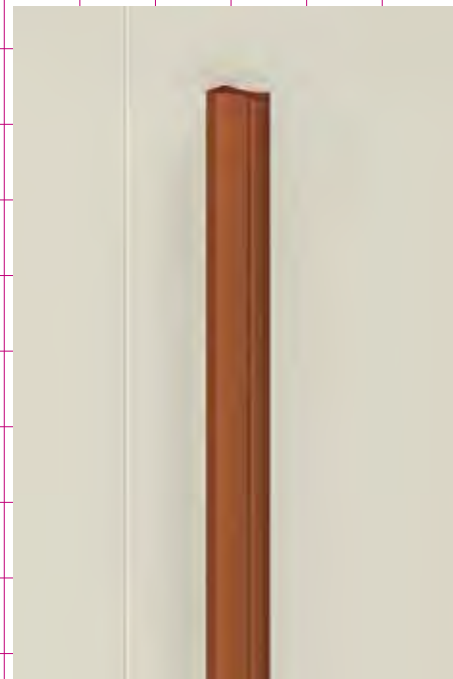

IT Maniglia M16.
EN M16 handle.
FR Poignée M16.



IT Push-Pull.
EN Push-Pull.
FR Push-Pull.

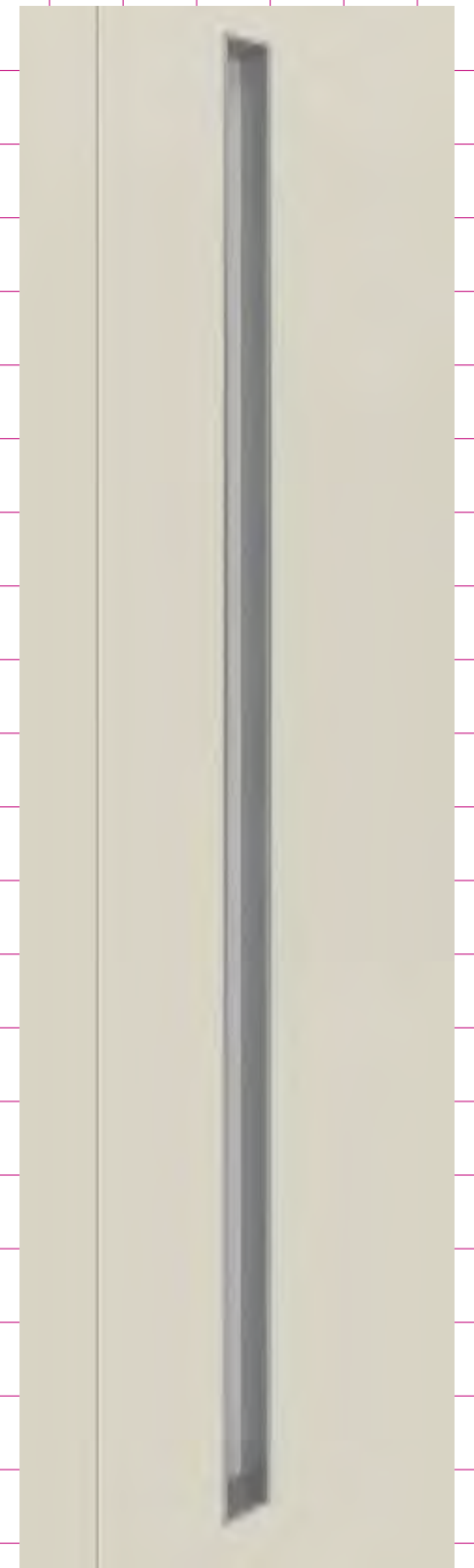

IT Maniglia M1.
EN M1 handle.
FR Poignée M1.

— Maniglie

EN Handles / FR Poignées



IT Maniglia M11 in rovere.
EN M11 oak handle.
FR Poignée M11 en chêne.



IT Maniglia M12 in rovere.
EN M12 oak handle.
FR Poignée M12 en chêne.



IT Maniglia M13 in rovere.
EN M13 oak handle.
FR Poignée M13 en chêne.

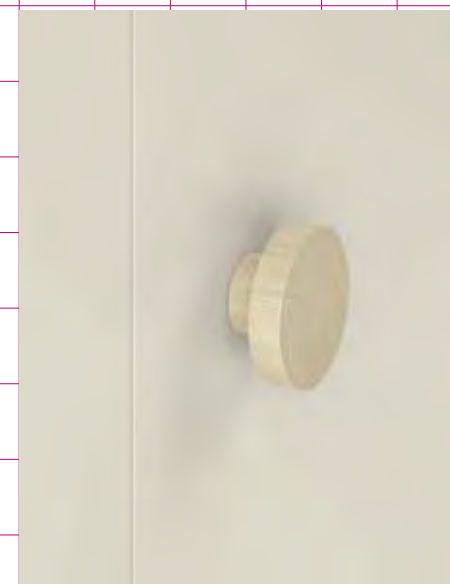

IT Maniglia M18 in acero.
EN M18 maple handle.
FR Poignée M18 en érable.

— Maniglie

EN Handles / FR Poignées

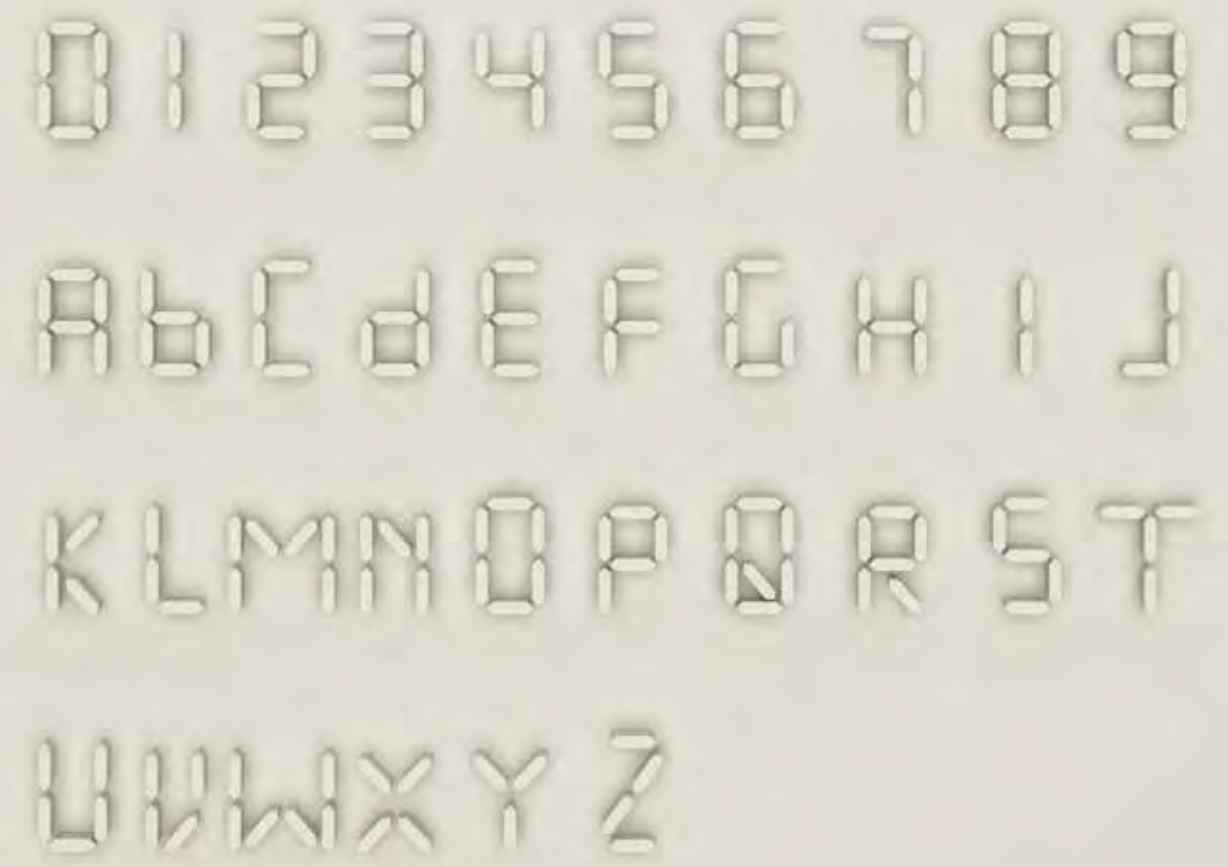
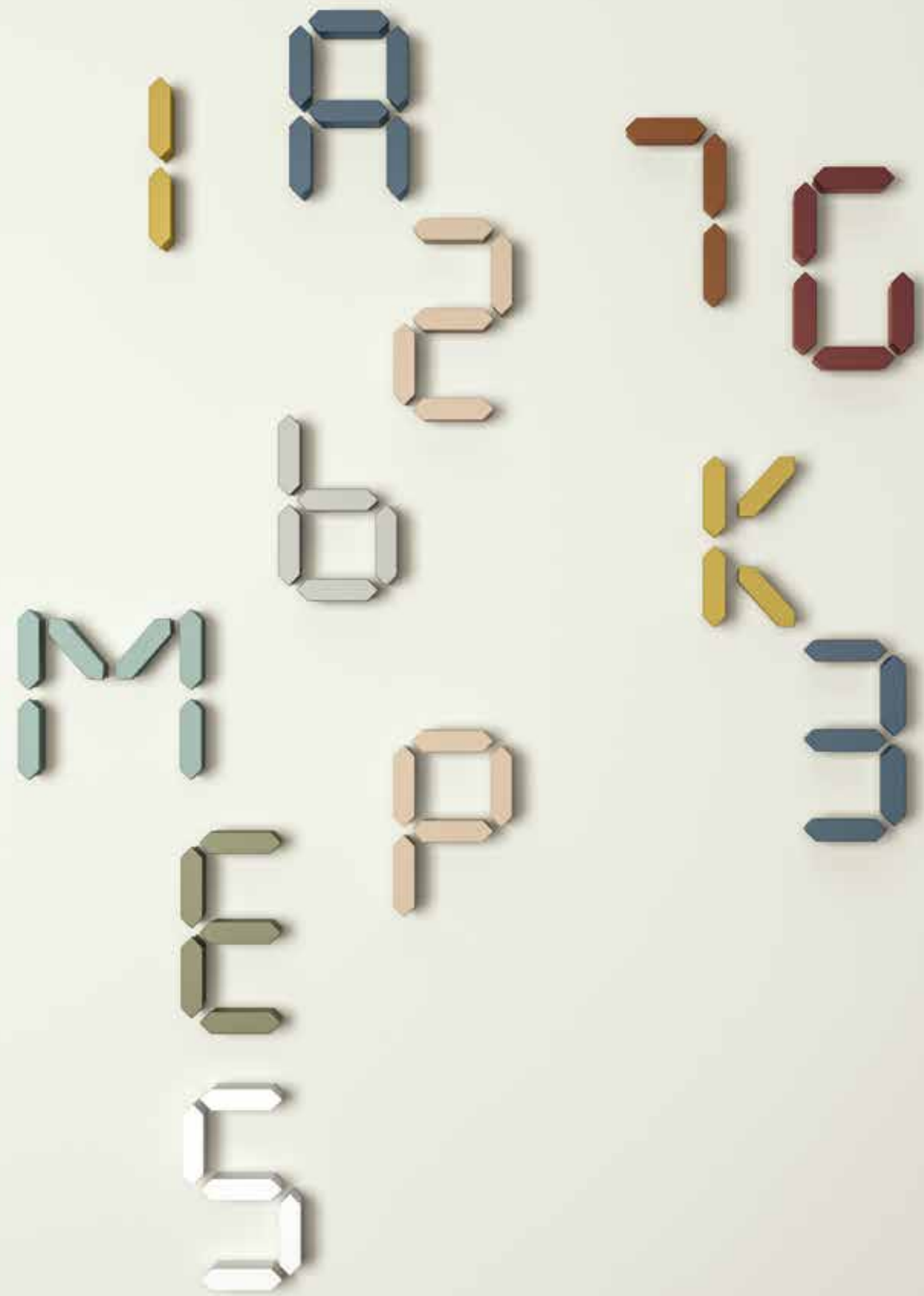

IT Maniglia M7.
EN M7 handle.
FR Poignée M7.

— **Multibox - Infinity**

EN Multibox - Infinity / FR Multibox - Infinity

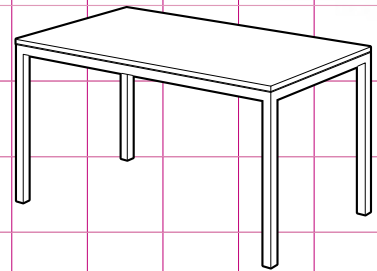

INFINITY 01

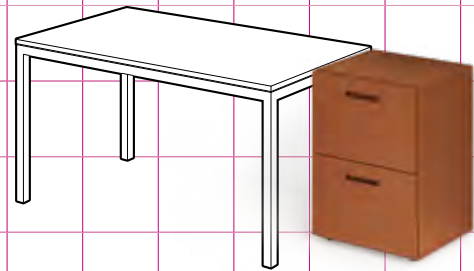

MULTIBOX 02

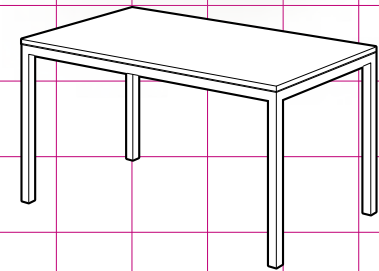

MULTIBOX 03

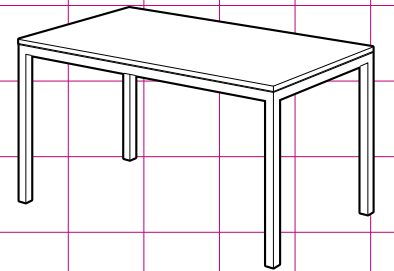

MULTIBOX 04

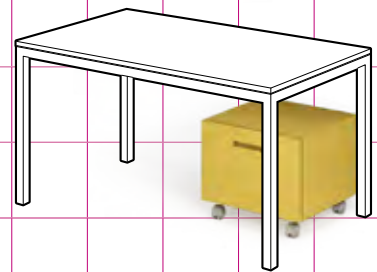

MULTIBOX 05

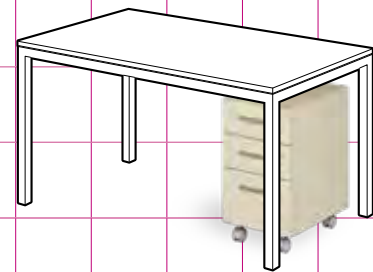

MULTIBOX 06

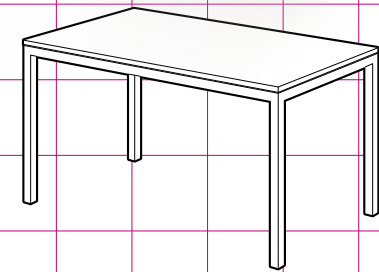

MULTIBOX 07

— Multibox - Infinity

EN Multibox - Infinity / FR Multibox - Infinity

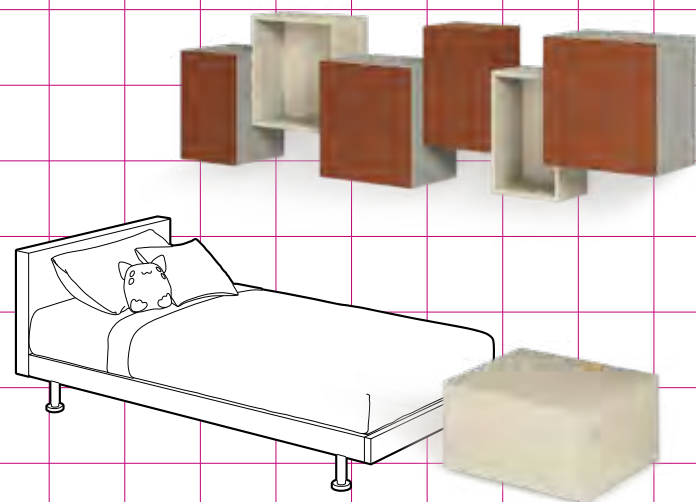

MULTIBOX 08

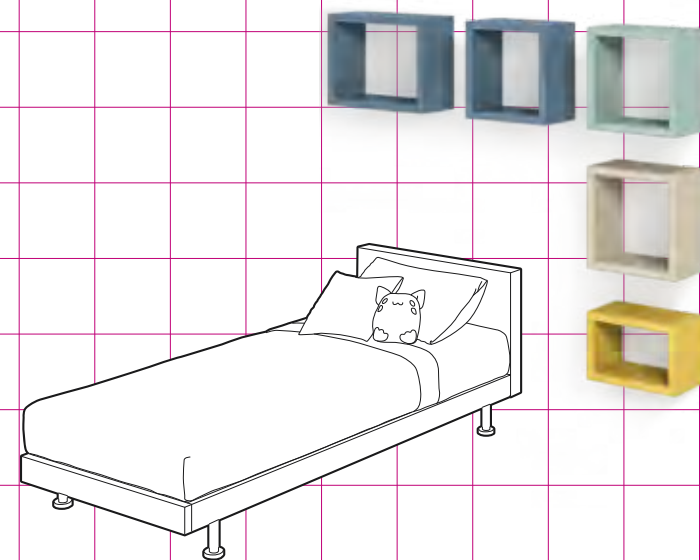

INFINITY 09

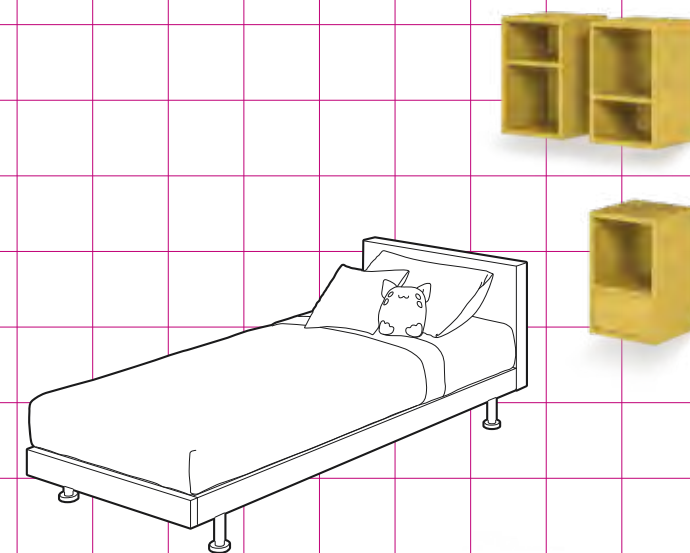

MULTIBOX 10

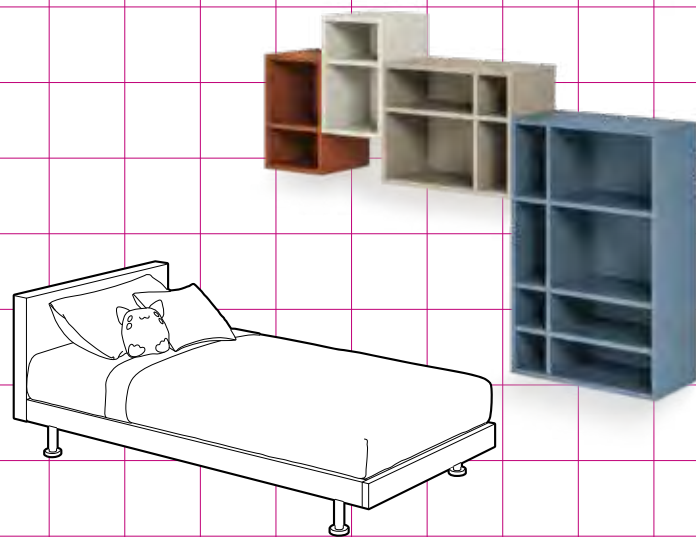

MULTIBOX 11

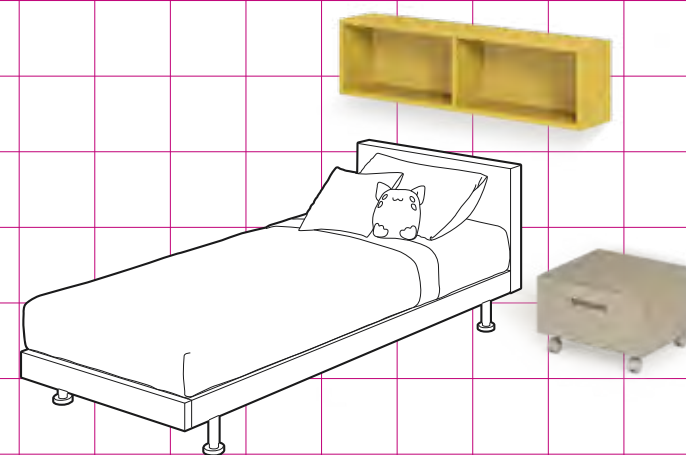

MULTIBOX 12

— Scrivanie

EN Desks / **FR** Bureaux

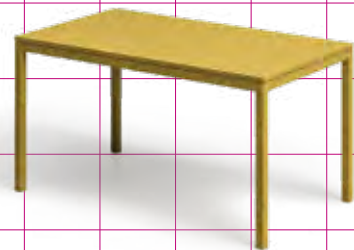

IT Scrivani con struttura in metallo.
EN Desks with metal structure.
FR Bureaux avec structure en métal.



IT Scrivani con struttura in metallo.
EN Desks with metal structure.
FR Bureaux avec structure en métal.



IT Scrivani con struttura in nobilitato.
EN Desks with melamine structure.
FR Bureaux avec structure en mélamine.

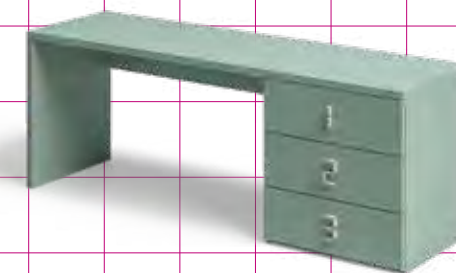

IT Scrivani con struttura in nobilitato.
EN Desks with melamine structure.
FR Bureaux avec structure en mélamine.



IT Scrivani con struttura in metallo su ruote.
EN Desks with metal legs and wheels.
FR Bureaux avec pieds en métal et roulettes.



IT Scrivani con struttura in metallo.
EN Desks with metal structure.
FR Bureaux avec structure en métal.



IT Scrivani RIBE.
EN RIBE desks.
FR Bureaux RIBE.



IT Scrivani RIBE.
EN RIBE desks.
FR Bureaux RIBE.

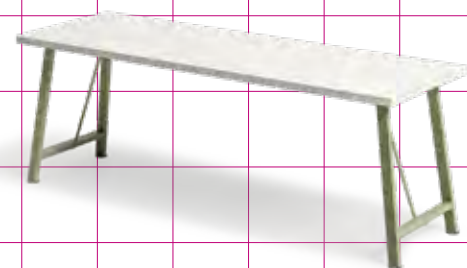

IT Scrivani con struttura COAST TO COAST.
EN Desks with COAST TO COAST structure.
FR Bureaux avec structure COAST TO COAST.

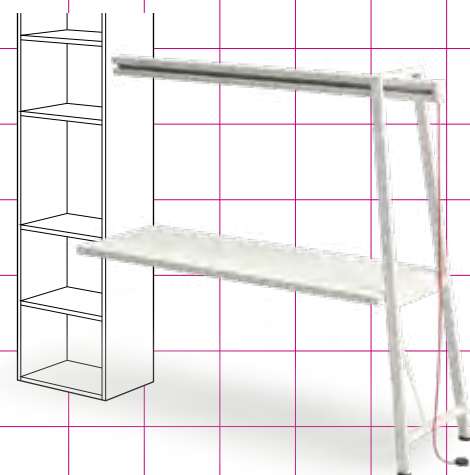

IT Scrivani con struttura COAST TO COAST.
EN Desks with COAST TO COAST structure.
FR Bureaux avec structure COAST TO COAST.

— Sedie e pouf

EN Chairs and pouf / FR Chaises et pouf



IT Sedia con meccanismo di alzata e cuscino.
EN Chair with seat height adjustment and pad.
FR Chaise avec hauteur réglable et coussin.



IT Sedia in polipropilene.
EN Polypropylene chair.
FR Chaise en polypropylène.



IT Pouf RIBE.
EN RIBE pouf.
FR Pouf RIBE.



IT Pouf sagomato.
EN Shaped pouf.
FR Pouf modelé.



IT Sgabello con meccanismo di alzata.
EN Stool with seat height adjustment.
FR Tabouret avec hauteur réglable.

— Prodotti che durano nel tempo

EN Products that last over time / FR Produits qui durent dans le temps



EN Designed to transform over time and made with high quality materials, ERBA furnishing solutions have a longer life cycle than traditional bedrooms. They contribute to the reduction of consumptions and pollution, related to industrial processes, and also to the waste disposal, for a better world.

FR Conçues pour se transformer dans le temps et réalisées avec matériaux de qualité, les solutions ERBA ont une vie beaucoup plus longue que les chambres traditionnelles. Elles contribuent à réduire la consommation et la pollution liée aux processus industriels et aussi à l'élimination des déchets, pour un monde meilleur.

— Territorio

EN Area / FR Région

Dal 1958 Erba opera nel Distretto del Mobile della Brianza

Mariano Comense



— Conoscenza, ricerca, passione per la qualità dell'arredo e della vita, in un luogo nel quale la migliore tradizione manifatturiera, incontra la cultura del progetto e l'innovazione tecnologica. Una somma di valori che fanno la differenza, per un progetto multiforme e in continua evoluzione. Dalla camera dei ragazzi, al guardaroba, agli ambienti di servizio, Erba interpreta l'abitare nel segno della personalizzazione e della flessibilità che diventa stile.

EN Since 1958 Erba works in Brianza, the Furnishing District par excellence.

Knowledge, research, passion for design and life quality, in a place where the best manufacturing tradition meets the project culture and the technological innovation. Values that make the difference for a multifaceted project in constant evolution. Kids' bedrooms, wardrobes, and service spaces: customization and flexibility are the foundations of the Erba style.

FR Depuis 1958, Erba travaille dans la Brianza, le District du Meuble.

Connaissance, recherche, passion pour la qualité du mobilier et de la vie, dans une région où la meilleure tradition manufacturière rencontre la culture du projet et de l'innovation. Un ensemble de valeurs qui font la différence dans un projet multiforme et en constante évolution. La chambre d'enfants, les armoires, l'aménagement des locaux de service, Erba interprète l'art du vivre la maison sous le signe de la personnalisation et de la flexibilité qui devient un vrai style.



— Azienda

EN Company / FR Entreprise

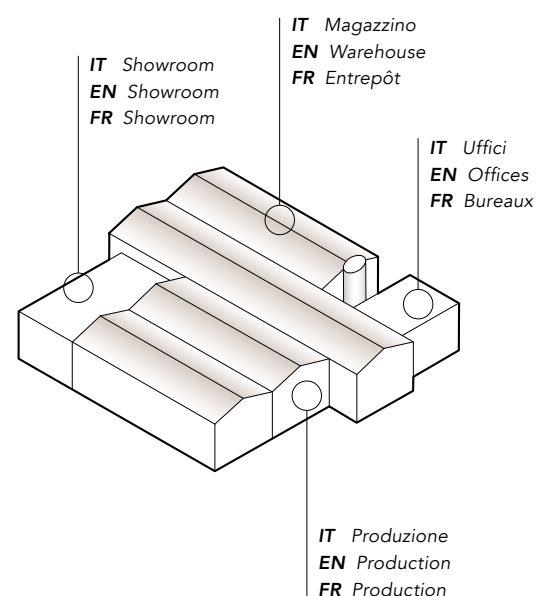

— Da più di **50 anni** Erba è presente nel mercato dell'arredo. L'unità produttiva e lo showroom sorgono nel Distretto della **Brianza**, territorio noto per l'eccellenza produttiva nel settore arredo di fascia medio-alta e per le forti competenze tecniche e potenziale creativo. Il prodotto Erba viene concepito come un capo sartoriale. Nasce da qui il desiderio di "**vestirlo**" al meglio. "**Sartorialità**" significa anche "**a misura**", uno dei servizi che contraddistingue l'azienda.

EN For more than **50 years**, Erba has been present in the furnishing industry.

The production centre and showroom are located in **Brianza**, an area famous for high-end excellent furnishing production, expert workmanship, technical skills, and great creativity.

The product Erba is like a tailored suit. This gives rise to the desire to better "**dress**" the product. "**Tailoring**" also means "**made-to-measure**", one of the services that distinguishes the company.

FR Depuis plus de **50 ans** Erba est présente sur le marché de l'ameublement.

La production et le showroom se trouvent dans la région de la **Brianza**, territoire connu pour ses excellents produits de gamme moyenne supérieure dans le secteur de l'ameublement et pour les grandes compétences techniques et son potentiel de créativité.

Le produit Erba est le résultat du travail d'un atelier de couture. C'est ici que naît le désir d'"**habiller**" le produit au mieux. "**Haute couture**" signifie également "**sur mesure**", un des services qui caractérise l'entreprise.



Un percorso organizzato e puntuale, dalla progettazione al punto vendita.

Una realtà fatta di persone e tecnologie. Grazie a sistemi di produzione di ultima generazione, Erba ha innalzato i livelli di produttività e di controllo sulla qualità, restando fedele ai migliori valori del Made in Italy.

EN A well-organized and accurate process, from the project to the dealer.

An entity made up of people and technologies. Thanks to the forefront production systems, Erba has raised its levels of productions and quality control, staying loyal to the best Made in Italy values.

FR Un parcours organisé et ponctuel, à partir de la conception jusqu'au le revendeur.

Une réalité faite de personnes et de technologies. Grâce aux systèmes de production de dernière génération, Erba a augmenté les niveaux de productivité et de contrôle de la qualité, tout en restant fidèle aux meilleures valeurs du Made in Italy.



IT I prodotti sono ampiamente personalizzabili nelle finiture e nelle dimensioni grazie ad un sistema produttivo su commessa.

EN The possibilities of product customization are really wide, both in finishes and sizes, thanks to the production system just in time.

FR Les produits sont largement personnalisables dans les finitions et les dimensions grâce à un système de production sur commande.

1



IT L'estrema cura degli imballaggi riduce quasi a zero (0,05%) i reclami.

EN Extreme care for packaging reduces complaints almost to zero (0,05%).

FR L'attention extrême pour l'emballage réduit presque à zéro (0,05%) les services après vente.

3

4

IT Erba offre un servizio di consegna rapido per soddisfare richieste particolari.

EN Erba offers a service of fast delivery in order to satisfy particular requests.

FR Erba offre un service de livraison très rapide pour pouvoir satisfaire des demandes spéciales.

5

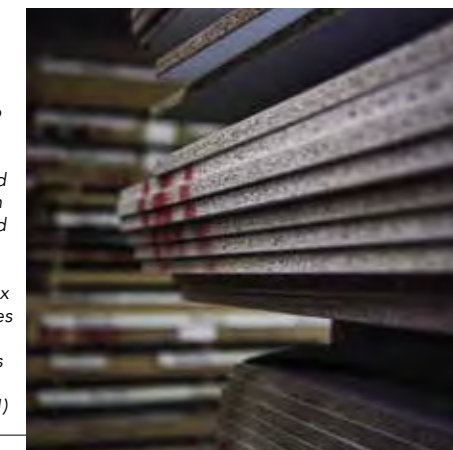

IT Tutti i materiali utilizzati rispettano le normative europee di sicurezza ed hanno un basso livello di emissioni (E1).

EN All materials used respect the European safety regulations and have a low emissions level (E1).

FR Tous les matériaux utilisés sont conformes aux normes de sécurité européennes et ils sont à un niveau réduit d'émissions (E1)

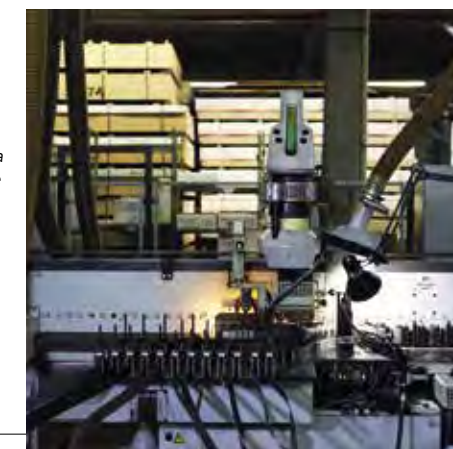

IT L'elevato livello di automazione accelera i tempi di produzione e di consegna.

EN The high level of automation makes the production and delivery time shorter.

FR Le haut niveau d'automatisation accélère les délais de production et de livraison.



“ Le persone hanno bisogno di continui stimoli per essere motivate ed agire con il cuore, perché quando si fa una cosa volentieri, la si fa bene. Il nostro spirito di collaborazione ci permette di dare forma a idee, prodotti, servizi di alta qualità. La sinergia con i nostri clienti ci porta a raggiungere insieme grandi traguardi. ”

Alessandro Erba

EN “People need continuous stimulation for being motivated and working with heart. When you do something with pleasure, you do it well. Our cooperation allows us to give shape to ideas, products and high quality services. The partnership with our customers leads us to achieve great goals.”

FR “Les gens ont besoin d'être stimulés en permanence pour être motivés et agir avec le cœur. Si vous faites quelque chose volontiers, vous le faites bien. Notre esprit de collaboration nous permet de donner forme à des idées, à des produits et à des services de haute qualité. La synergie avec nos clients nous conduit à obtenir de gros résultats.”



ERBA

Via Don Guanella, 28 C.P. 119
22066 Mariano Comense (Como)
Italy
T. +39 031 746 663
F. +39 031 750 624
erba@erbamobili.it
www.erbamobili.it

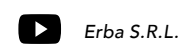
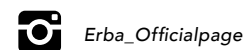

associato a:



Art direction / Graphic / Digital image / Styling Genny Canton Studio
Photo page 155 - 157 - 159 David Hatters
Copy Daniele Varelli
Color Correction Studio Emmequadro
Printed by Sinchromia

February 2020

