

magg

welcome to



our world





mogg Scheda tecnica
Data sheet

PIANTA | PLAN
FRONTE | FRONT

METRICA A Libreria | Bookcase







Designer: Ctrizak
Anno | Year: 2017
Materiali | Materials: Struttura in metallo verniciato con ripiani in vetro | Painted metal structure with glass shelves





MGGG srl via A. de Gasperi 76 20833 | Gussano (MB) | Italy | t. +39 0362 1723880 | f. +39 0362 1585432 | www.mogg.it | info@mogg.it MADE IN ITALY

Inquadra il qr code con il tuo smartphone per vedere la scheda tecnica del prodotto.

Use your smartphone to scan the qr code and see the product sheet.

novità /
news

					
mochi p. 44	narciso p. 52	divina p. 58	costantina opal p. 64	shape p. 72	metrica lamp p. 78

				
matrix p. 4	rio p. 14	skyfall p. 20	plier p. 28	lunee p. 34

matrix
design Bellavista Piccini

2025



Tavolino in cemento. Disponibile nei colori: taupe, brick, smoke, pearl.

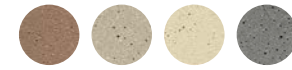

Coffee table in concrete. Available in colours; taupe, brick, smoke, pearl.

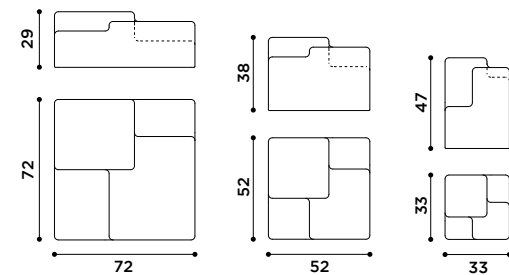







rio
design Alain Gilles

2025



Letto imbottito. Struttura imbottita con rivestimento sfoderabile nei tessuti come da campionario.

Upholstered bed. Padded structure with removable cover in fabrics as per our sample card.

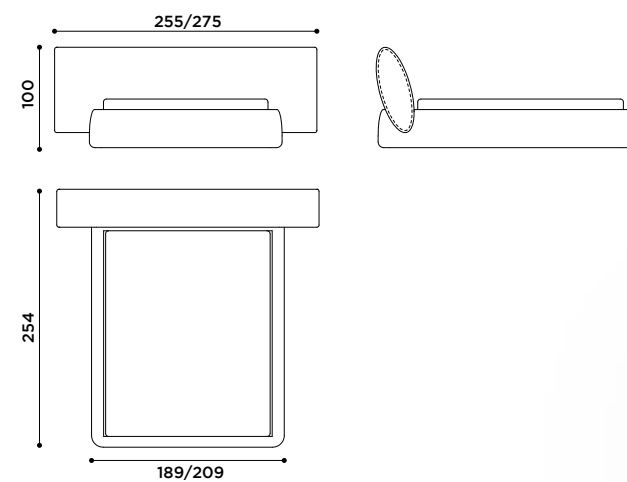





mogg



skyfall
design Alessandro Di Prisco

2025



Poltroncina imbottita. Struttura imbottita con rivestimento non sfoderabile nei tessuti come da campionario.

Upholstered armchair. Padded structure with non-removable cover in fabrics as per our sample card.

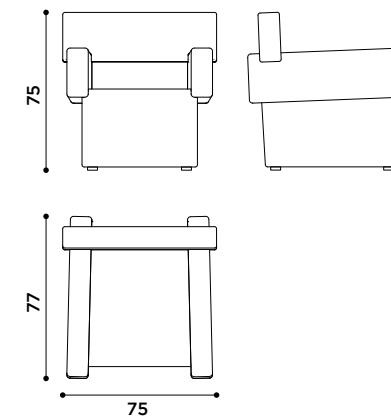









Lampada da parete in metallo.
Disponibile nelle finiture: Delabrè D_01 oro,
Delabrè D_02 peltro,
Delabrè D_03 oyster.



*Wall lamp in metal. Available in the
finishes: Delabrè D_01 gold, Delabrè
D_02 peltro, Delabrè D_03 oyster.*

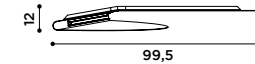
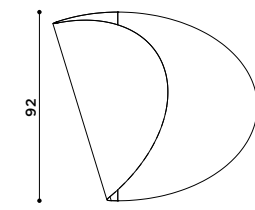
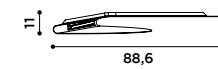
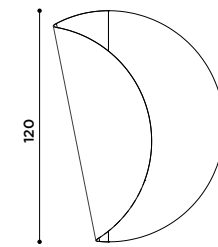





lunee
design Marcantonio

2025



Sedia in multistrato di legno curvato. Disponibile in frassino naturale, tinto moka oppure tinto iroko. Versione imbottita con rivestimento non sfoderabile nei tessuti come da campionario.

Chair in curved plywood. Available in natural ash-wood, moka stained or iroko stained colours. Upholstered version with non-removable cover in fabrics as per our sample card.

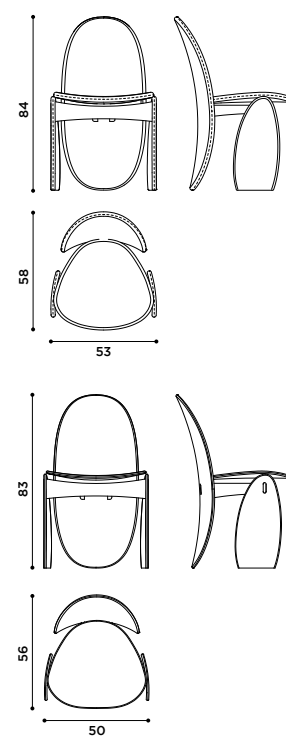



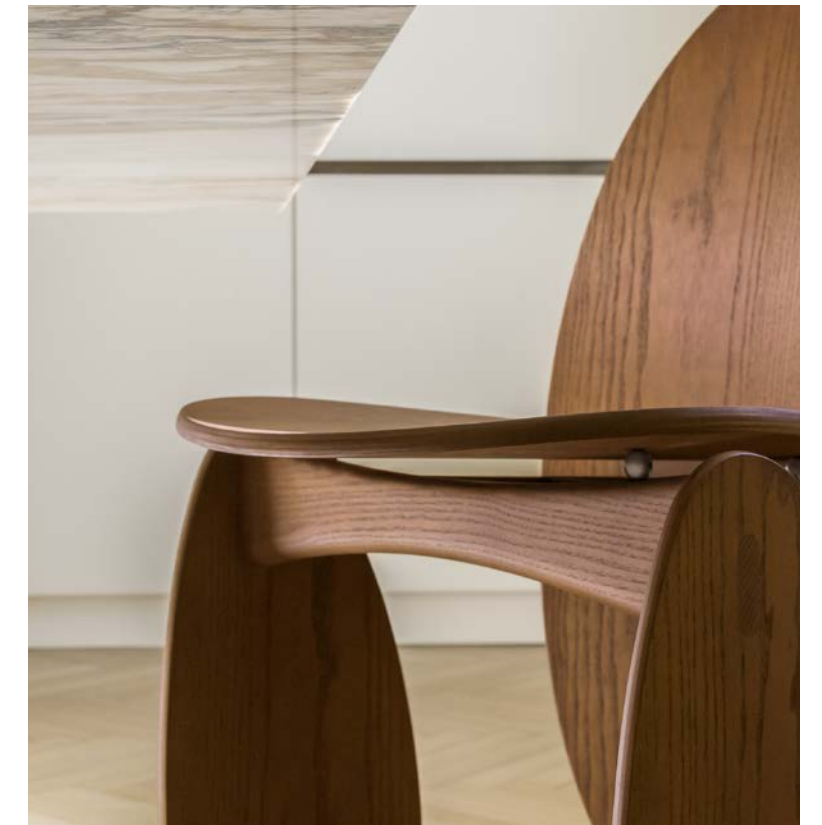
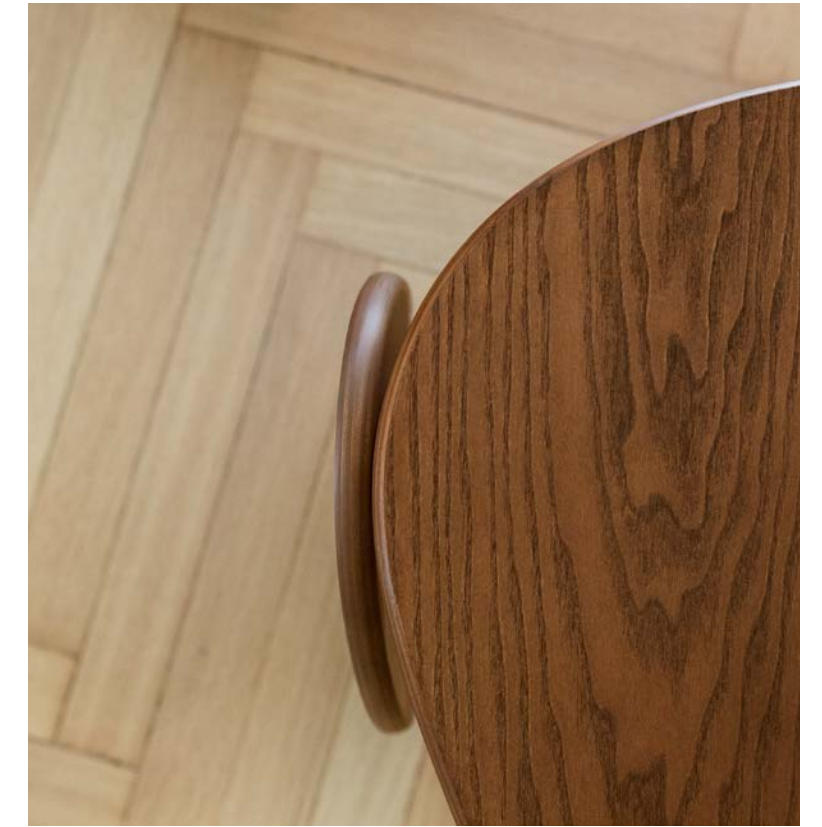





mochi
design Arthur De Menezes



Poltroncina imbottita. Struttura imbottita con rivestimento non sfoderabile nei tessuti bi-elastici come da campionario.

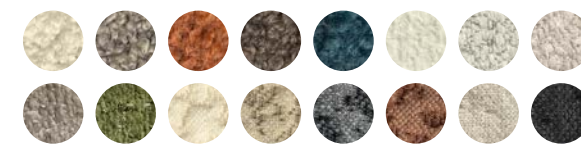

Upholstered armchair. Padded structure with non-removable cover in bi-elastic fabrics as per our sample card.

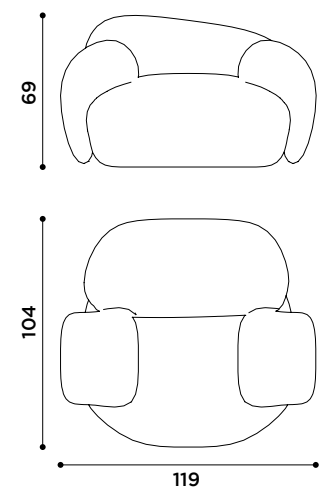







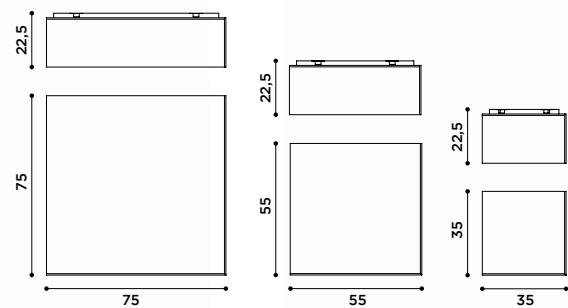

Specchio a parete con mensola.

Wall mirror with shelf.







Portabottiglie in metallo da parete.
Disponibile nelle finiture: brunito,
cromato.



*Wall metal bottle-holder. Finishes:
burnished, chromed.*

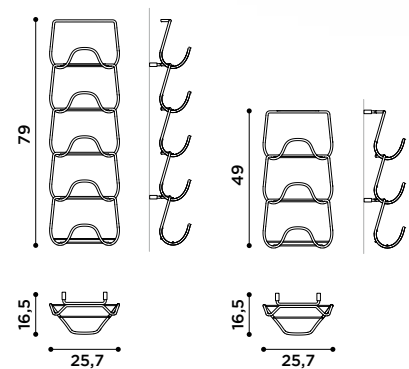

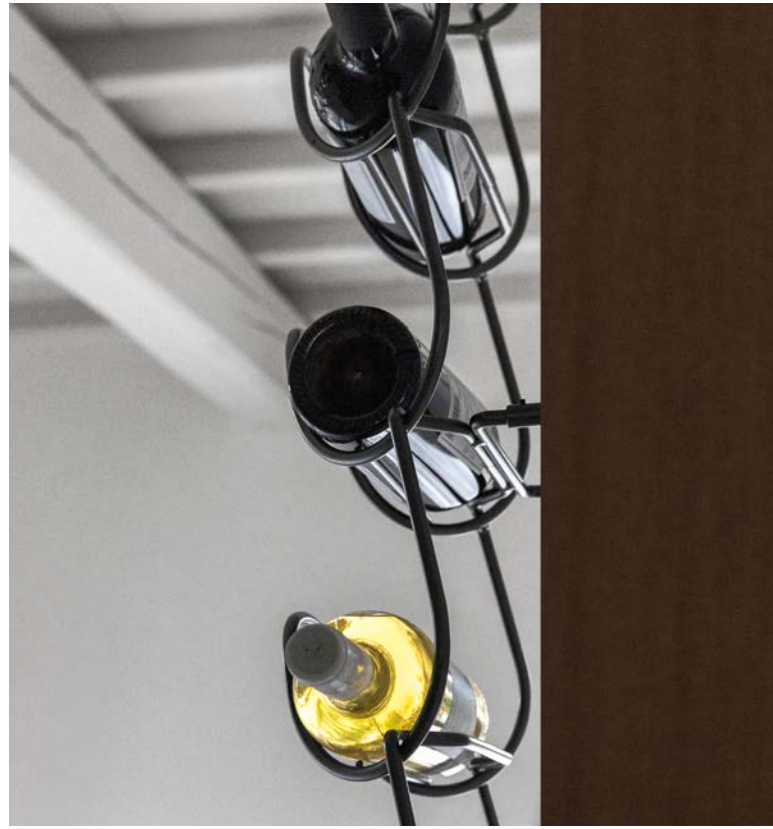



costantina opal
design Nava + Arosio

2025



Lampada da terra e da tavolo.
Struttura in metallo e paralumi in
vetro soffiato opale.

*Floor and table lamp. Metal
structure and opal blown glass
lampshades.*

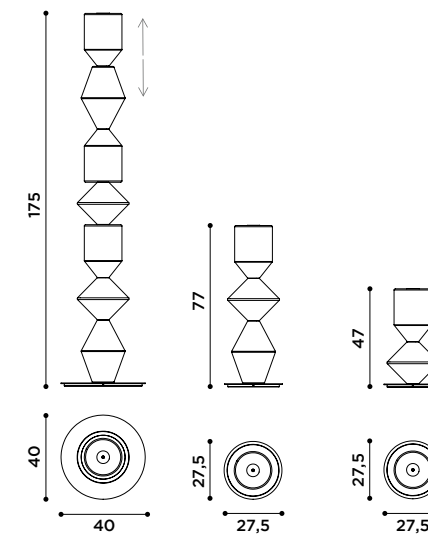







shape
design Uto Balmoral



Console in MDF. Finiture: laccata opaco o lucido in tutti i colori come da campionario o materico spatolato a mano nei colori: bianco, nero, grigio, avorio, terracotta

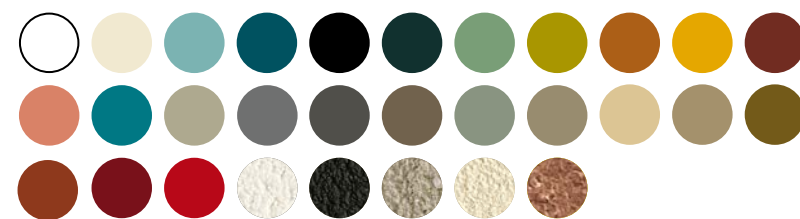

Console in MDF. Finiture: matt or glossy lacquered as colors card or covered with hand-spread materic finish in the colours: white, black, grey, ivory, terracotta.

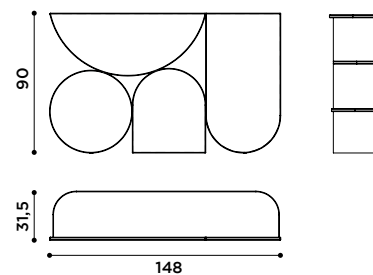





metrica lamp
design Ctrlzak

2025



Lampada a sospensione con struttura in metallo. Disponibile nelle finiture: brunito e oro.



Pendant lamp with metal frame. Finishes: burnished, gold.

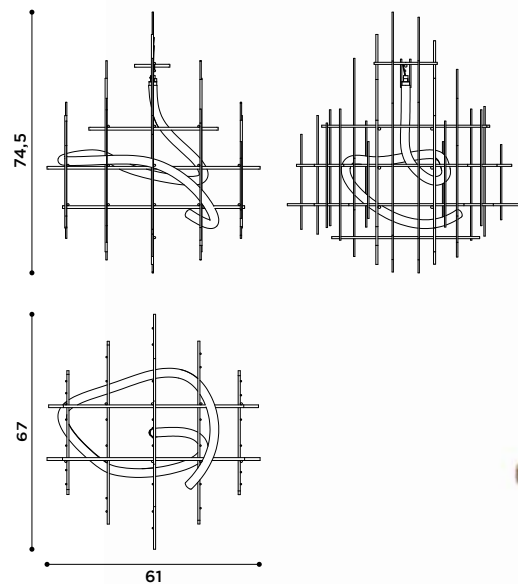

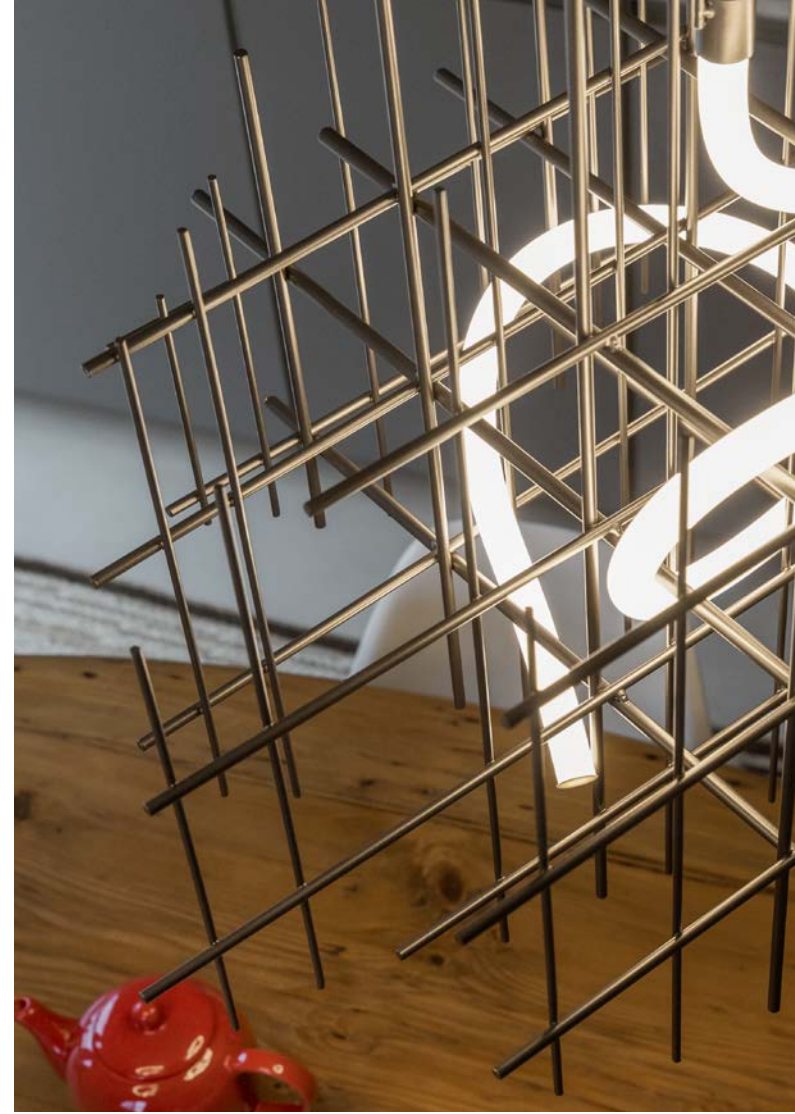
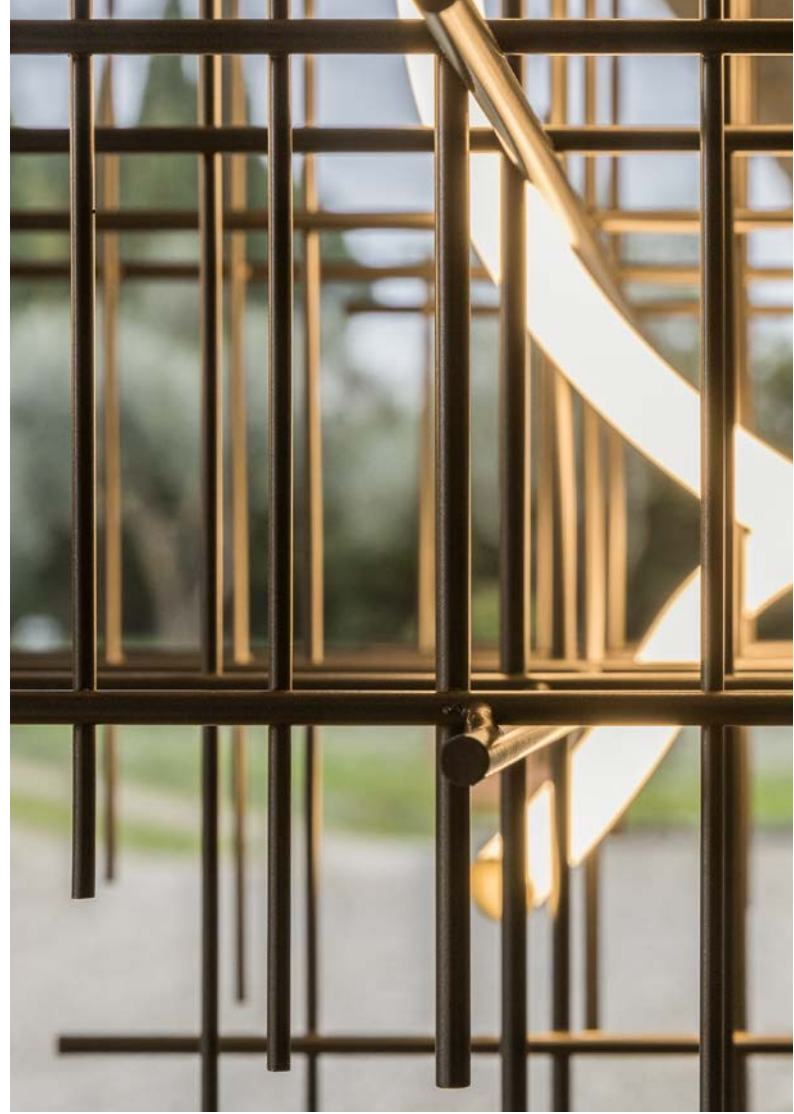

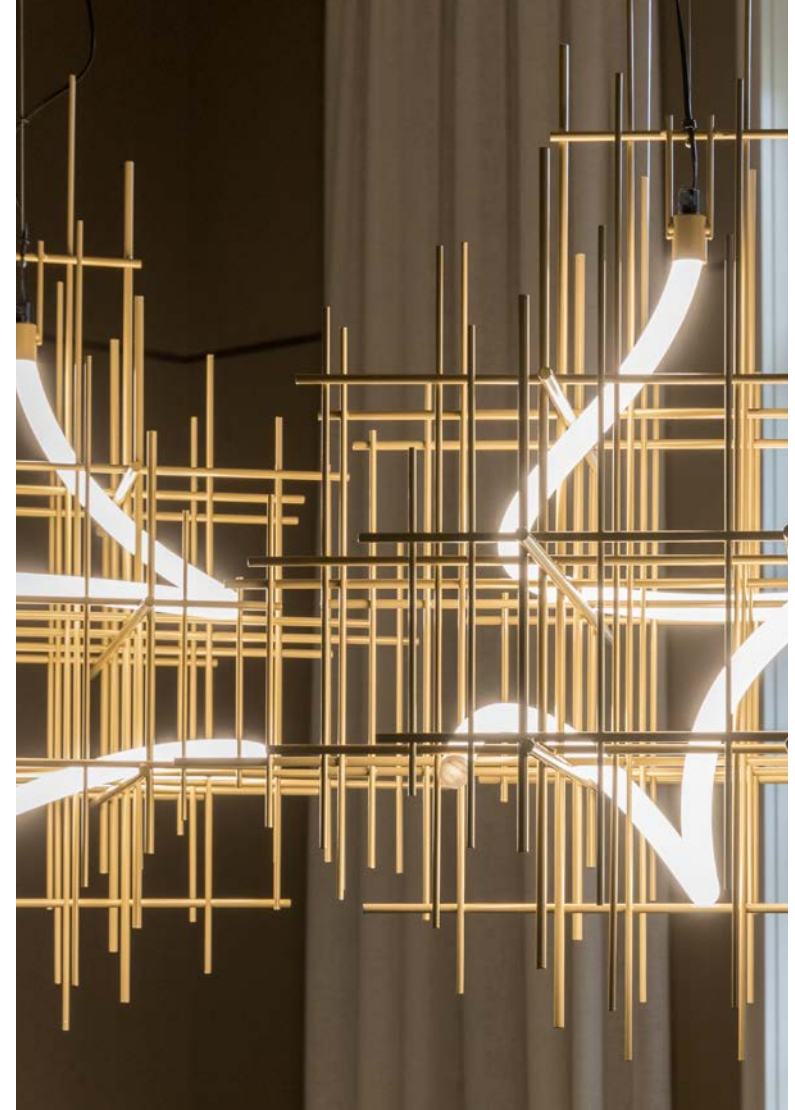

PANNO / FINEST WOOL

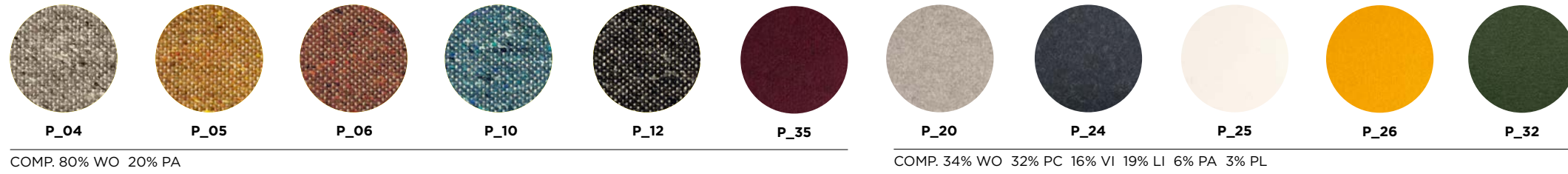

COTONE / COTTON

COMP. 100%CO

I tessuti possono variare di tonalità da una partita all'altra. L'azienda non si assume responsabilità in caso di eventuali differenze di colore. La stampa dei colori è indicativa. *Fabrics can show differences in colours from batch to batch. The company declines any responsibility in case of any colour differences. Colours printing is indicative.*

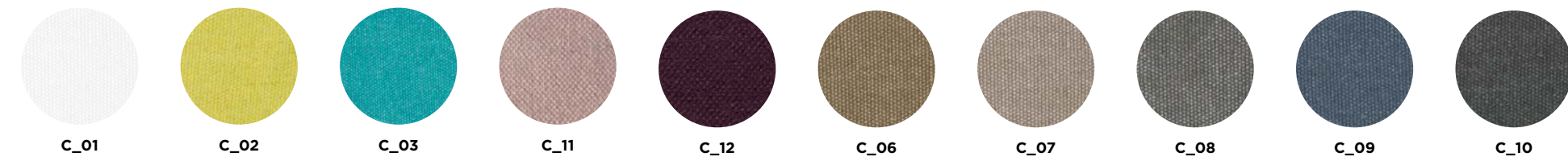

LINO / LINEN COMP. 100% LI

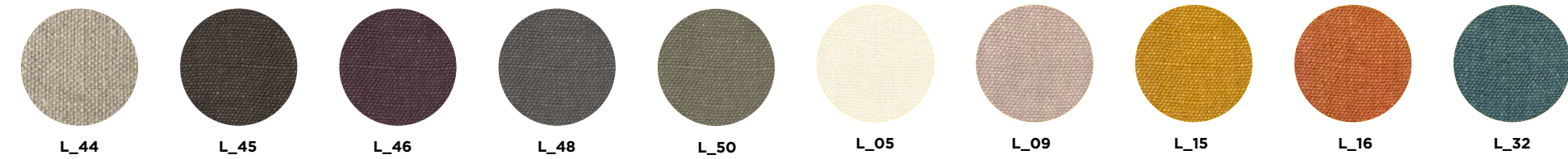

TEXTURE 1

I tessuti possono variare di tonalità da una partita all'altra. L'azienda non si assume responsabilità in caso di eventuali differenze di colore. La stampa dei colori è indicativa. *Fabrics can show differences in colours from batch to batch. The company declines any responsibility in case of any colour differences. Colours printing is indicative.*



TEXTURE 2

I tessuti possono variare di tonalità da una partita all'altra. L'azienda non si assume responsabilità in caso di eventuali differenze di colore. La stampa dei colori è indicativa. *Fabrics can show differences in colours from batch to batch. The company declines any responsibility in case of any colour differences. Colours printing is indicative.*

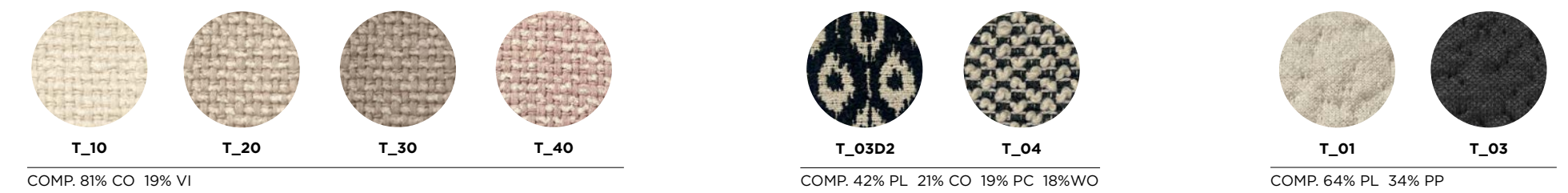

TEXTURE 3

I tessuti possono variare di tonalità da una partita all'altra. L'azienda non si assume responsabilità in caso di eventuali differenze di colore. La stampa dei colori è indicativa. *Fabrics can show differences in colours from batch to batch. The company declines any responsibility in case of any colour differences. Colours printing is indicative.*

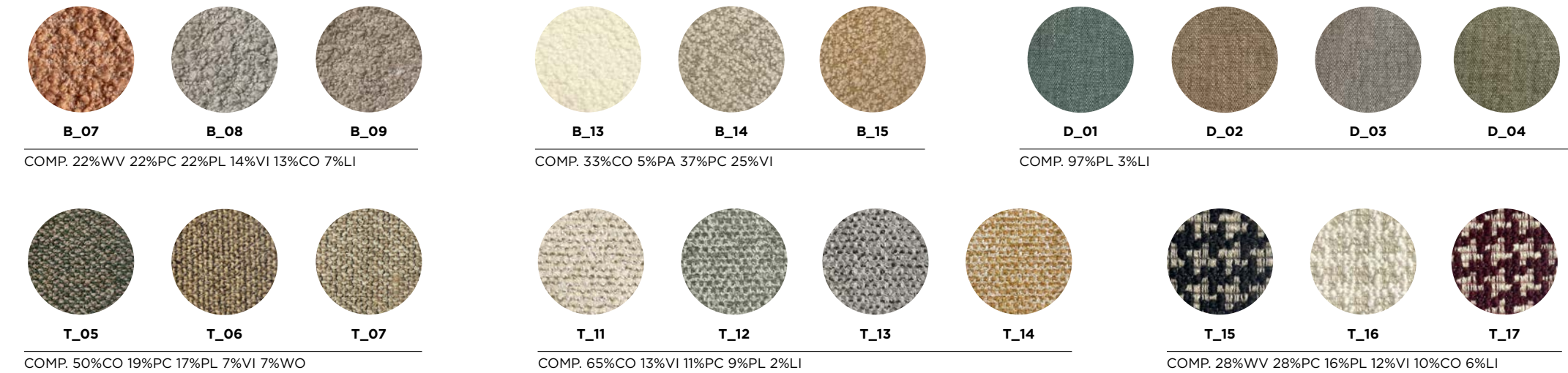

BIELASTICI / BIELASTICS

I tessuti possono variare di tonalità da una partita all'altra. L'azienda non si assume responsabilità in caso di eventuali differenze di colore. La stampa dei colori è indicativa. *Fabrics can show differences in colours from batch to batch. The company declines any responsibility in case of any colour differences. Colours printing is indicative.*



PELLI / LEATHER

Le pelli sono materiali unici. La presenza di piccoli graffi o differenze nell'uniformità sono caratteristiche e pregi della vera pelle e non devono essere considerati difetti. *Leathers are one-of-a-kind materials. The presence of small scratches or scars are characteristics and virtues of true leather and should not be considered defects.*



FONO ASSORBENTI / SOUND-ABSORBING FABRICS COMP. 54% JU 46% LI

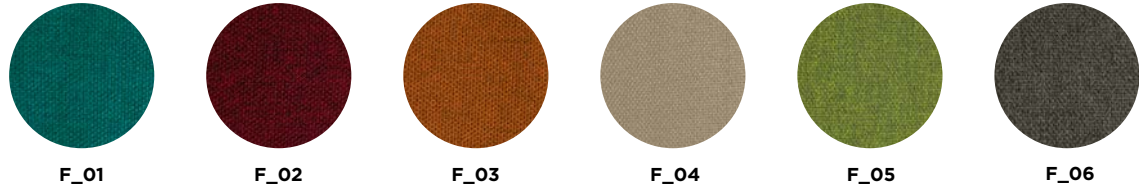

METALLO / METAL

I materiali possono variare di tonalità da una partita all'altra. L'azienda non si assume responsabilità in caso di eventuali differenze di colore. La stampa dei colori è indicativa. *Materials can show differences in colours from batch to batch. The company declines any responsibility in case of any colour differences. Colours printing is indicative.*



LEGNO / WOOD



MATERICI / MATERIALS

I materiali possono variare di tonalità da una partita all'altra. L'azienda non si assume responsabilità in caso di eventuali differenze di colore. La stampa dei colori è indicativa. *Materials can show differences in colours from batch to batch. The company declines any responsibility in case of any colour differences. Colours printing is indicative.*



VETRI / GLASSES



MOGG srl

via A. da Giussano 76
20833 Giussano MB ITALY
t. +39 0362 1723880
info@mogg.it
www.mogg.it

THANKS TO:

Eda Milano
Editions Milano
Studio_Pepa

PROGETTO GRAFICO:

jekyll & hyde

STYLING:

alessandro pasinelli studio

FOTOGRAFIE:

ezio manciucca
tiziano sartorio

POST PRODUCTION E STAMPA:

Azzerboni Printing srl

STAMPA:

Giugno 2025

