

GIORGETTI



PLACES TO LIVE SINCE 1898



Places to live since 1898

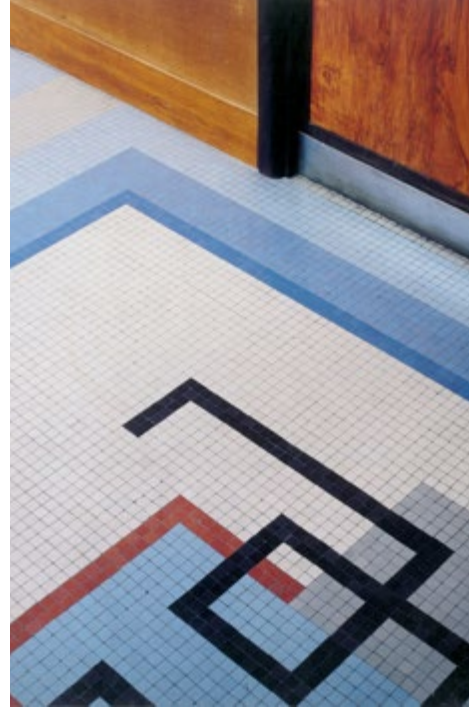

Villa Il Girasole,
the revolving house

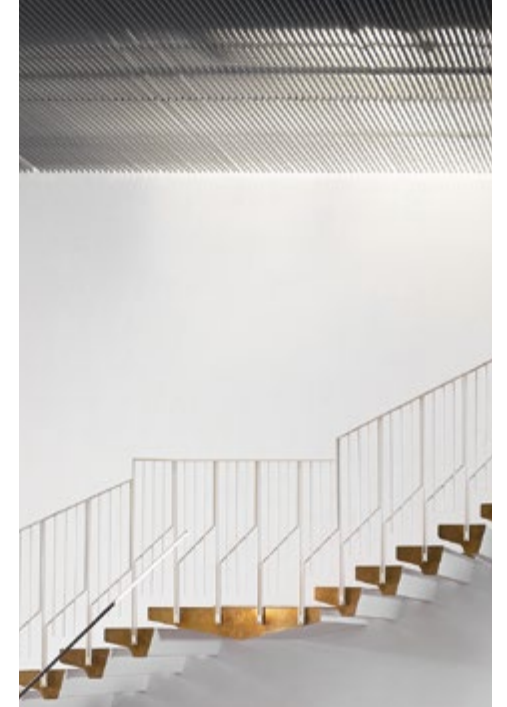

Milan, a grand tour

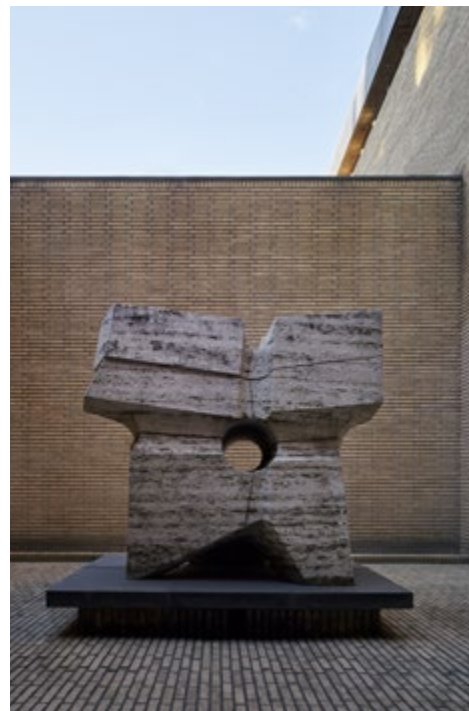

Debut at Academy

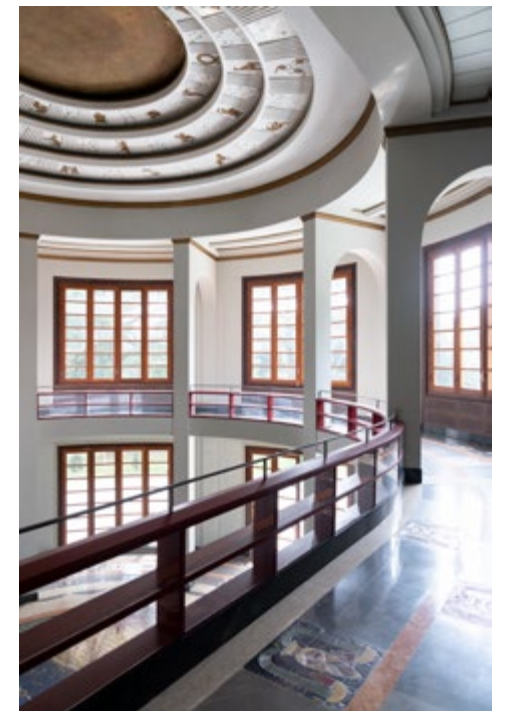

A small oasis from the late 1930



A house where the Renaissance
meets contemporary art

EN — Places to live.

The first rotating house.
Four historic buildings.
Three academic foundations.
A palatial building.
A residence.

A veronese hill.
A city of hubbub and points of convergence.
A valley with a park.
A thermal spring.
Three lakes.

A visionary architecture.
Extraordinary houses of the nineteenth-century Modernism.
An international enclave.
Rationalism.
Classicism.

Places of intimate and deep relationships with furnishing elements, in which to rediscover the pleasure of living, in which to feel good.

Design and art intertwine. A stylistic vision nourished by creative influences.

Giorgetti continues to respond to the **transformation of the home** into a more flexible, multitasking place and a setting for changing lifestyles. An evolution that expresses a **fluid and broad vision of living** that goes beyond domestic walls and increasingly permeates even hospitality venues.

IT — Spazi da vivere.

La prima casa rotante.
Quattro edifici storici.
Tre Accademie.
Un palazzo.
Una residenza.

Una collina veronese.
Una città di fermenti e convergenze.
Una valle con un parco.
Una sorgente termale.
Tre laghi.

Un'architettura visionaria.
Case gioiello del novecento modernista.
Un'enclave internazionale.
Razionalismo.
Classicismo.

Luoghi di relazioni intime e profonde con gli elementi d'arredo, in cui riscoprire il piacere dell'abitare, in cui sentirsi bene.

Design e arte si intrecciano. Una visione stilistica che si alimenta nelle contaminazioni creative.

Giorgetti continua a farsi interprete della **trasformazione della casa** in un luogo sempre più flessibile e multitasking, teatro di nuovi stili di vita. Un'evoluzione che racconta una **visione dell'abitare fluida e trasversale** che valica le mura domestiche e permea sempre più anche i luoghi.

Villa Il Girasole, the revolving house

Villa Il Girasole,
the revolving house

MARCELLISE 2025

EN — In the Italian garden, framed by reinforced concrete, wheels and railway tracks, cypresses, cherry trees and grapevines, Villa Il Girasole appears. Extraordinary and visionary this experimental rotating home was designed by Angelo Invernizzi to follow the sun, just like the flowers which inspired it.

Il Girasole was a comprehensive project, spanning from engineering to architecture and even marketing, as it had its own logotype. This coordinated identity was expressed in a veritable user's manual, distinguished by imagery relating to sunflowers ('girasole' in Italian) as the symbolic key.

IT — Nel giardino all'italiana tra cemento armato ruote e binari, cipressi ciliegi e vigne, appare Villa Il Girasole, uno straordinario e visionario esperimento di casa rotante, concepita da Angelo Invernizzi per inseguire il Sole, come fa il fiore a cui è ispirata.

È stato un progetto integrale, ingegneristico architettonico e di comunicazione, con un proprio logotipo, un'identità coordinata declinata in un vero e proprio manuale d'uso, contraddistinta dall'immaginario del girasole come chiave simbolica.

Villa Il Girasole, the revolving house

PLACES TO LIVE SINCE 1896



Lorelei sofas / divani

Floria table / tavolo

Otto poufs

Aei cabinet/ contenitore

Kukei sideboards / madie

Upward lamp / lampada

Neomeris carpet / tappeto



Lorelei sofas / divani

Floria table / tavolo

Neomeris carpet / tappeto



I've known Villa Il Girasole as an exceptional house for some time now a project which conjures marvel and awe, probably because it's utopian and futurist. It's an edifice built upon engineering expertise, but enlivened by imagination and fantasy. At first glance, it looks like the invention—or dream—of a scientist.

Villa Il Girasole: una casa eccezionale, un progetto capace di suscitare meraviglia e stupore, probabilmente perché utopico, futuristico. È un'architettura costruita su conoscenze ingegneristiche, ma mossa dall'immaginazione e dalla fantasia.



Villa Girasole, revolving house

PLACES TO LIVE SINCE 1898



Lorelei sofas / divani
Neomeris carpet / tappeto

Floria table / tavolo

Filare 24 bottle holder / portabottiglie



Wing and the revolving nois

CE 398



Floria table / tavolo

Plume chairs / sedie

Charlotte cabinet / contenitore

Water lamps / lampade

Blow wall sculptures / sculture da parete

Atena, Amorfo vase / vaso

Panopea carpets / tappeti

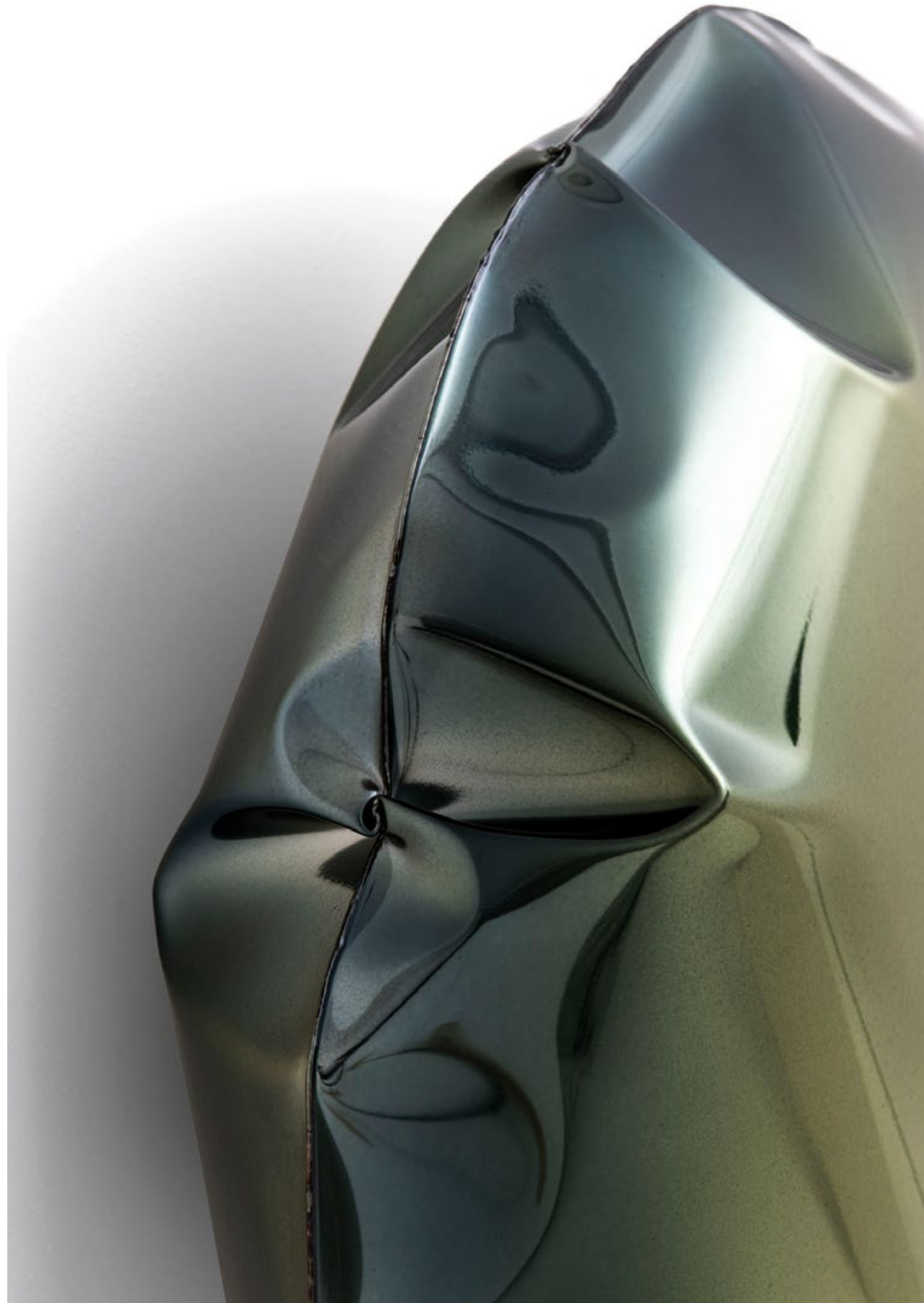

Villa Il Girasole, the revolving house

PLACES TO LIVE SINCE 1898



Plume chair / sedia

Floria table / tavolo

Plume chair / sedia

Panopea carpets / tappeti



Villa Il Girasole, the revolving house

PLACES TO LIVE SINCE 1898





The home—a place where incompatible elements coexist, from stillness and movement to a rationalist approach and a futurist sensibility—brings lightness to reinforced concrete. It makes that which is affixed mobile, and it makes buildings smart, just as home automation would almost a century later.

La villa - un luogo di coabitazioni impossibili tra staticità e movimento, tra approccio razionalista e sensibilità futurista - rende lieve il cemento armato, mobile ciò che è fisso, intelligente l'edificio come farà quasi un secolo dopo la rivoluzione domotica.



Seidon sofa / divano

Seidon sofas / divani

Attitude carpet / tappeto

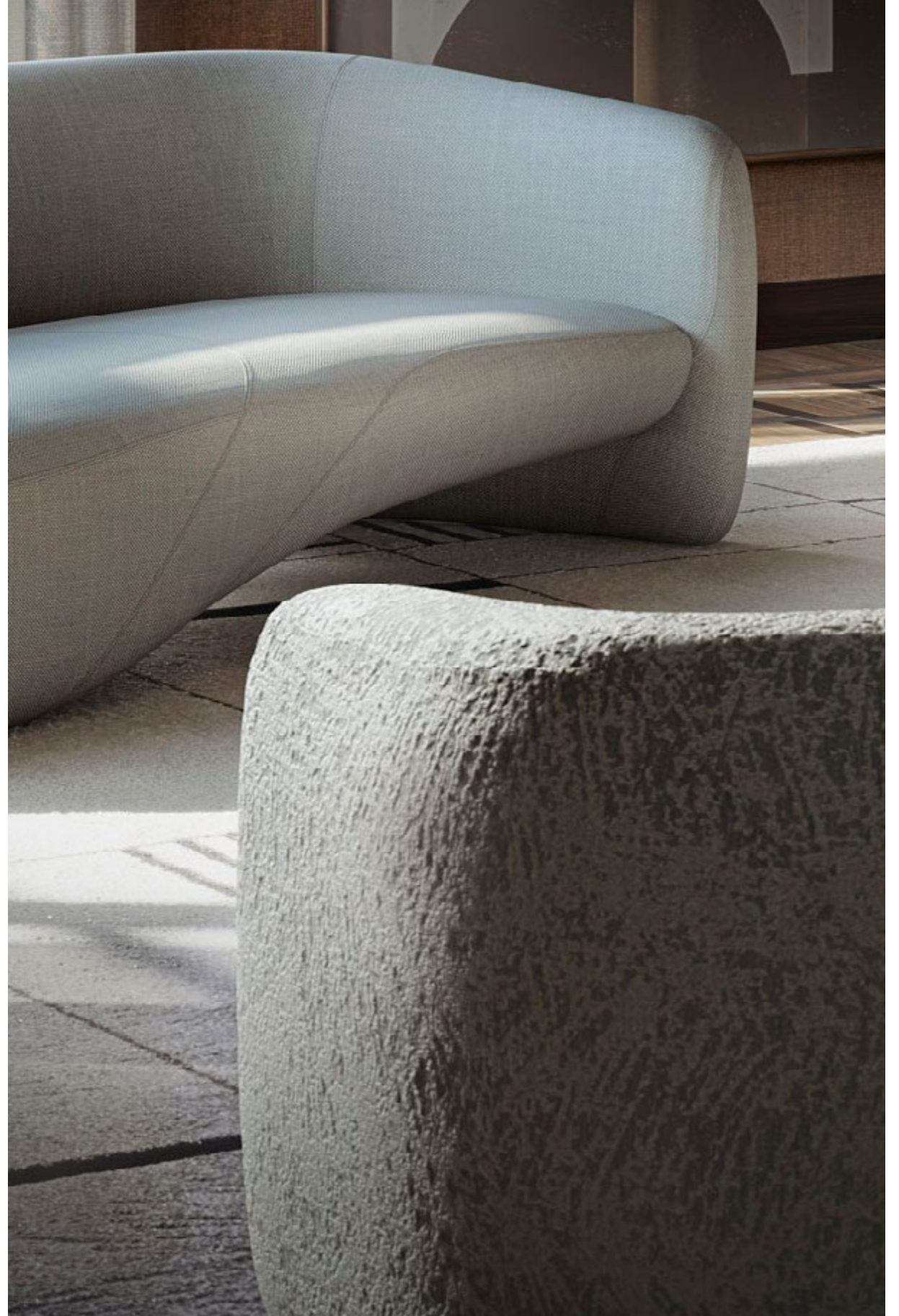

Seidon sofas / divani

Nastus, Vanity vases / vasi

Teti, Vesper poufs

Attitude carpets / tappeti

Galet, Kromis low tables / tavolini

Scirocco sideboard / madia

Upward lamp / lampada

Sliver lamps / lampade



Villa Il Girasole, the revolving house

PLACES TO LIVE SINCE 1898



Teti pouf

Villa Il Girasole is a challenging and courageous project where 'reinforced concrete is endowed with the precision of mechanical engineering', Angelo Invernizzi once said with proud pragmatism. Happy to have made the most immobile of materials move, and to have offered rooms with a view in eternal and gentle movement.

Villa Il Girasole è un progetto sfidante e ardito, dove "il cemento armato può avere la precisione dell'ingegneria meccanica" - dirà con orgoglioso pragmatismo Angelo Invernizzi. Felice di avere fatto muovere il più immobile dei materiali, e di aver regalato camere con vista in perenne e gentile movimento.





Nereide sofa / divanoLigea, Ploto low tables / tavoliniClori armchair / poltronaLibra lamp / lampadaNastus, Bubbles vases / vasiNeomeris carpet / tappeto



Ligea low tables / tavolini

Neomeris carpet / tappeto



Villa Maullino, the revolving house

PLACES TO LIVE SINCE 1898

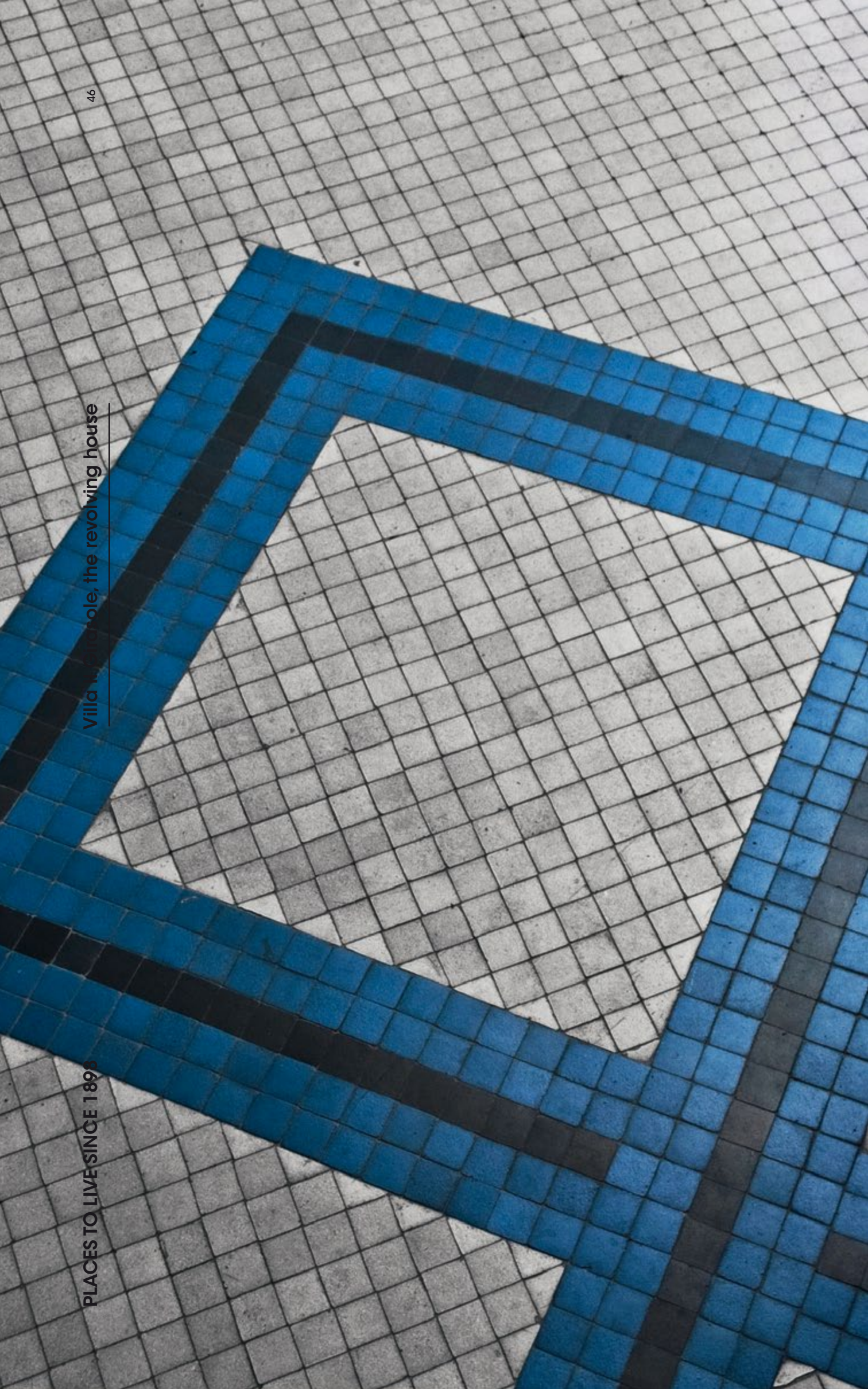

Nereide low table / tavolino



Neomeris carpet / tappeto



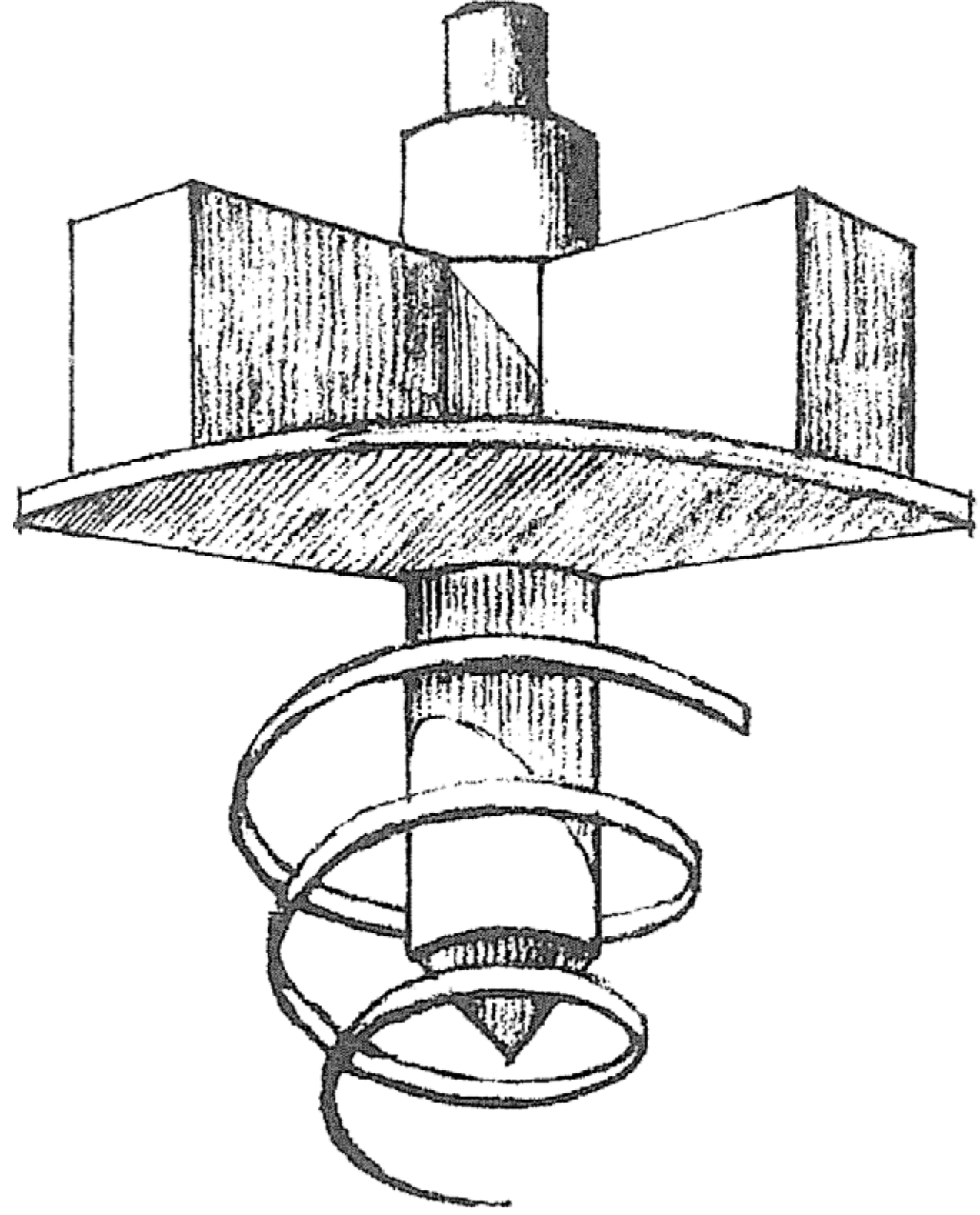

Ligea low table / tavolini

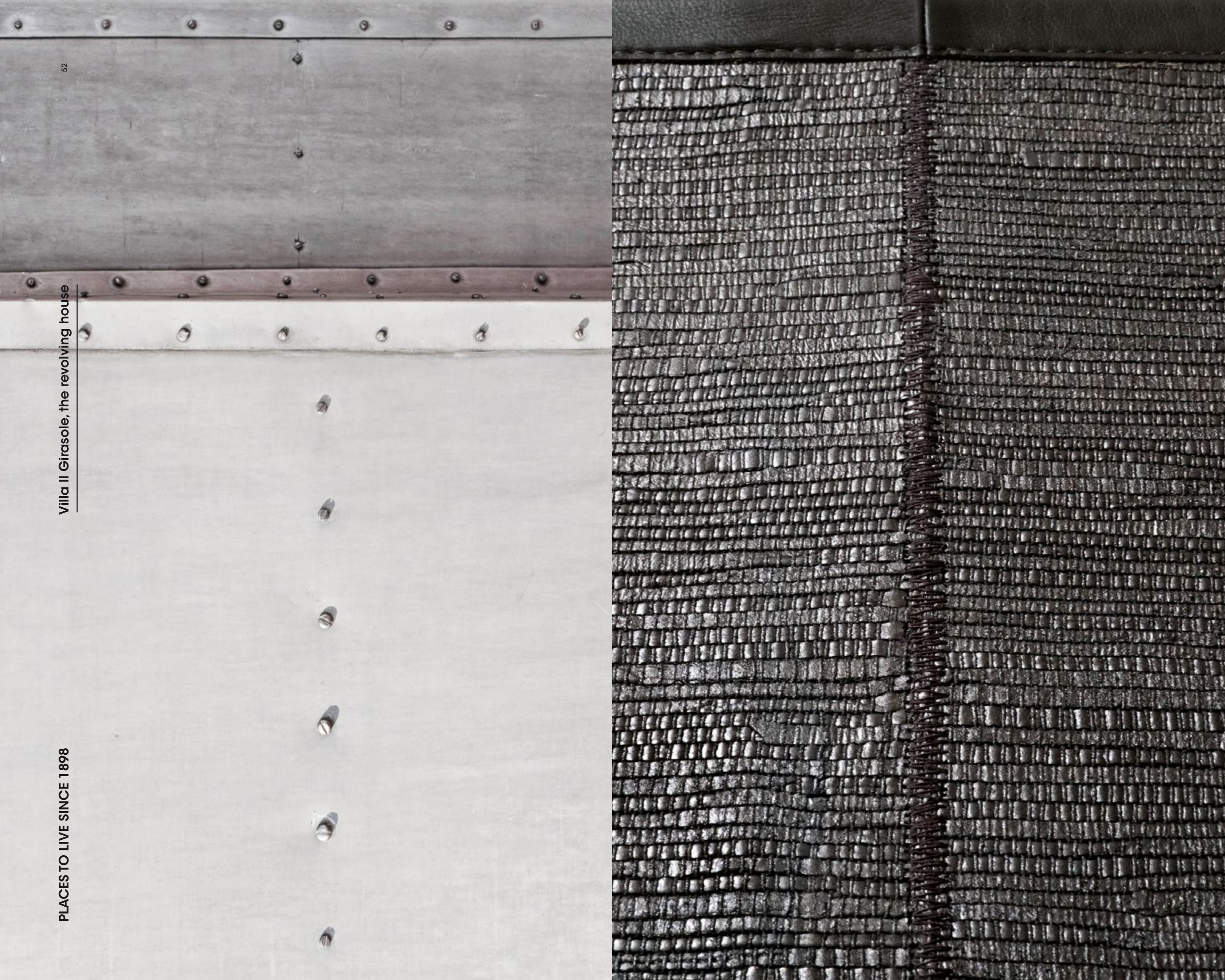

The structure is the only element in reinforced concrete, while all other internal components are defined by lightness: walls in Eraclit, panels covered in double wallpaper, the first being a thick adhesive layer which acted as glue, and the second being 'upholstery' in golden linen fabric. The hardwood floors are a triumph of three types of wood. This system of references, symmetries, and secret accords between symbols, alignments and numbers pervades and defines the entire project. It is one of the reasons the home is so alluring and mysterious.

Solo la struttura sarà in cemento armato, mentre ogni altra componente interna sarà all'insegna della leggerezza con le pareti in Eraclit, pannelli rivestiti da una doppia carta da parati, una prima adesiva e spessa che agiva come collante, una seconda in stoffa - lino dorato fissato con tesate. Il parquet sarà un virtuosismo di tre legni. Questa ricerca dei rimandi, delle simmetrie, delle segrete corrispondenze tra i simboli, gli allineamenti e i numeri pervade e connota l'intero progetto, ed è uno dei motivi di fascino, e mistero, della villa.

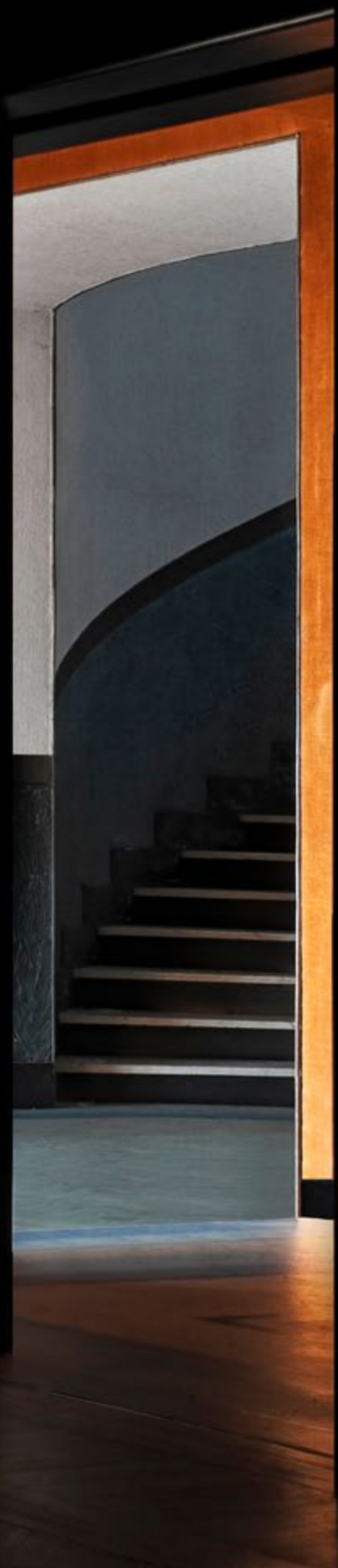

Nereide sofa / divano

Ploto low table / tavolino



Lorelei armchairs / poltrone

Spark low table / tavolino

Hikari bar cabinet

Kendama lamp / lampada

Hineri vases / vasi

Light carpet / tappeto



Villa Il Girasole, the revolving house

PLACES TO LIVE SINCE 1898



Lorelei armchair / poltrona

Spark low table / tavolino

Light carpet / tappeto





Tiber&Tiberina poufs, low tables / poufs, tavolini

Miyabi, Reiwa walk in closet / cabina armadio



Villa II Girasole, the revolving house

PLACES TO LIVE SINCE 1898



Sibilia low table / tavolino

Frame bed / letto

Sibilia low table / tavolino

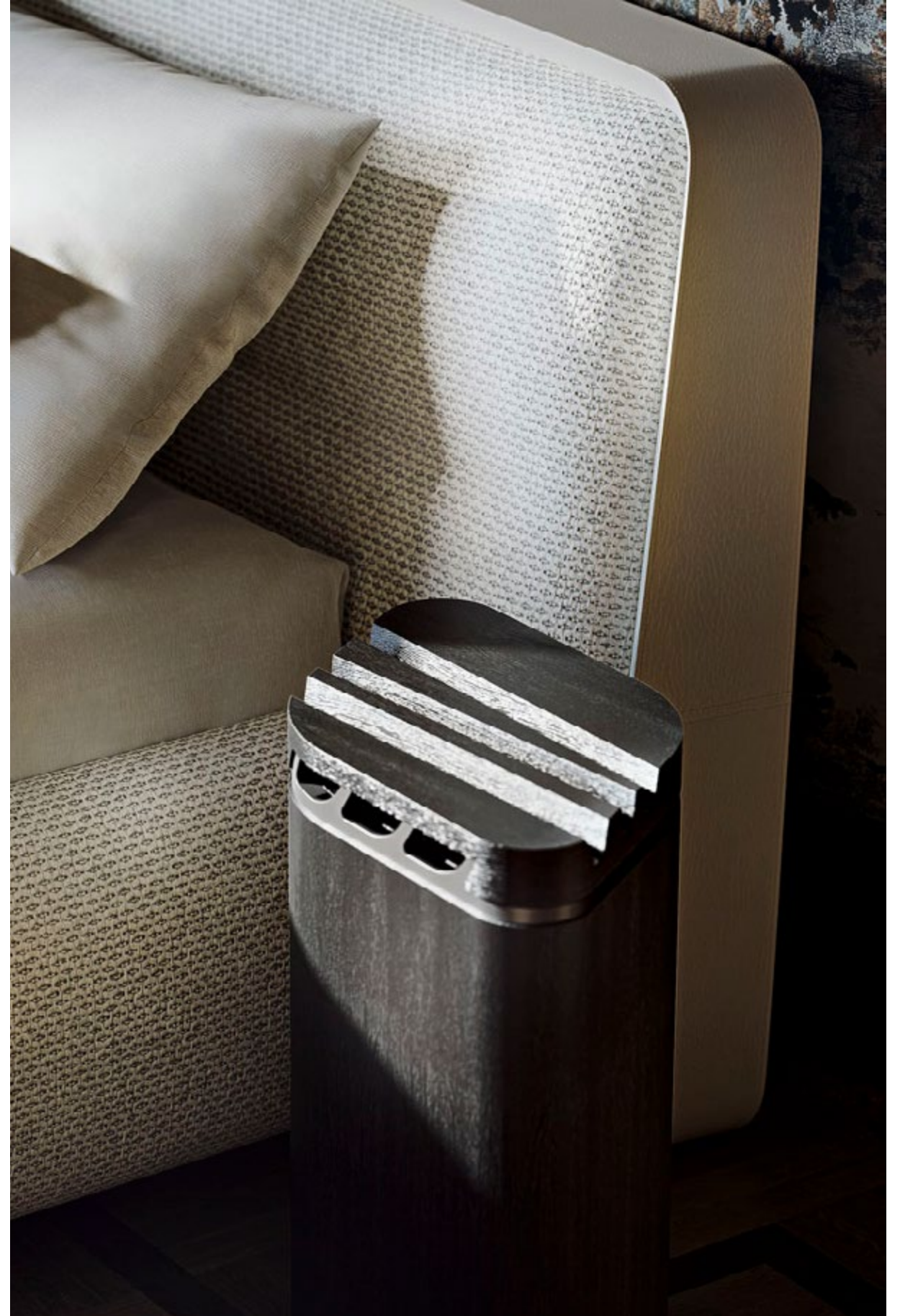

Frame bed / letto

All Around armchair / poltrona

Chanterelle, Dual, Sibilia low tables / tavolini

Beyond carpet / tappeto





Moorea table / tavolo

Moorea chairs / sedie

Marimo suspension ceramic vases / vasi in ceramica da sospensione

Nisida carpets / tappeti





Villa Ilse



Moorea chair / sedia

GK.01, GK.02 kitchen / cucina

Skirt stools / sgabelli

Floema plates / piatti





Moorea sofas / divani

Aldia low tables / tavolini

Nisida carpets / tappeti

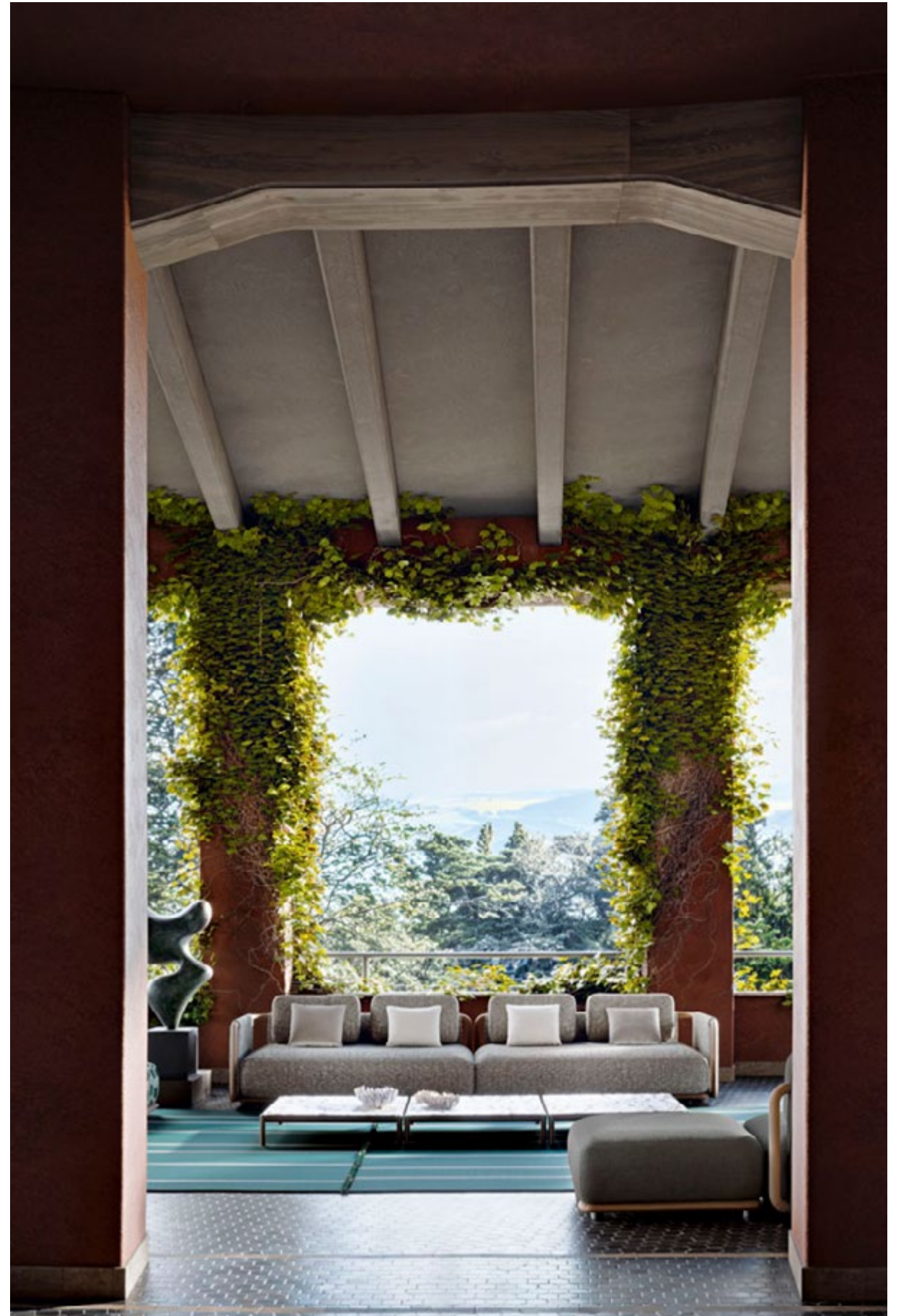

Moorea sofas / divani

Aldia low tables / tavolini

Nisida carpets / tappeti





Villa Il Girasole, the revolving house



PLACES TO LIVE SINCE 1898

Moorea sunbeds / lettini

Apsara, Kromis low tables / tavolini

Nisida carpets / tappeti



Villa Il Girasole, the revolving house



PLACES TO LIVE SINCE 1898

Moorea sunbed / lettino

Moorea sunbeds / lettini

Apsara low tables / tavolini

Nisida carpets / tappeti



Milan, a grand tour

Milan, a grand tour

PLACES TO LIVE SINCE 1898

Milan, a grand tour

MILANO 2024

EN — A backdrop of wonderful examples of Milanese nineteenth-century Modernist constructions. Behind the architecture itself are the stories of its origins and the visionaries who conceived and believed in these extraordinary buildings that were destined to house art, theatre or businesses or indeed, simply to incite wonder and appreciation: the Manzoni Theatre designed by Alziro Bergonzo in 1950, the Swiss Institute by Armin Meili and Giovanni Romano (1952), the PAC | Pavilion of Contemporary Art by Ignazio Gardella (1954) and the more recent Confcommercio offices designed by Eugenio Gerli in the late Sixties.

IT — Sulla trama antica della città si innalzano opere del Novecento modernista milanese. Dietro alle architetture ci sono le storie delle origini, di chi ha voluto e creduto in queste “case gioiello”, destinate ad accogliere l’arte, lo spettacolo, il commercio, o semplicemente a suscitare stupore e meraviglia: il Teatro Manzoni di Alziro Bergonzo, del 1950, l’Istituto Svizzero di Armin Meili e Giovanni Romano, del 1952, il PAC | Padiglione di Arte Contemporanea di Ignazio Gardella, del 1954, e, con un salto nel tempo, gli uffici di Confcommercio di Eugenio Gerli, di fine anni ’60.

PLACES TO LIVE SINCE 1898

Milan, a grand tour



Karphi Nap bed / letto

Delphi night table / comodino

Delphi chest /cassettone

Delphi chest of drawers/ cassetiera

Liz-valet valet / servomuto

Liz-bench bench / panca

Clori armchair and pouf / poltrona e pouf

Riff mirror / specchio

Nao lamp / lampada

Light carpet / tappeto

Brun Fine Art & Antiques Gallery: wood box with mother-of-pearl inlay details, made in Guangzhou, China; gold-finish bronze sculpture, Carlo Zauli; *Studio per il cavaliere nero*, Portoro marble sculpture, Andrea Cascella; gold-finish bronze sculpture on a stone base, Veronika von Eyck / scatola in legno intarsiato e dettagli in madreperla, lavorazione Cina Canton; scultura in bronzo dorato, Carlo Zauli; scultura *Studio per il cavaliere nero*, marmo Portovenere, Andrea Cascella; scultura in bronzo dorato su base in pietra, Veronika von Eyck



Karphi Nap bed / letto

Liz-valet valet / servomuto

Area tray / vassoio

Crystal Stone glasses / bicchieri



Liz-valet valet / servomuto



Milioni a grand tour

PLACES TO LIVE SINCE 1898

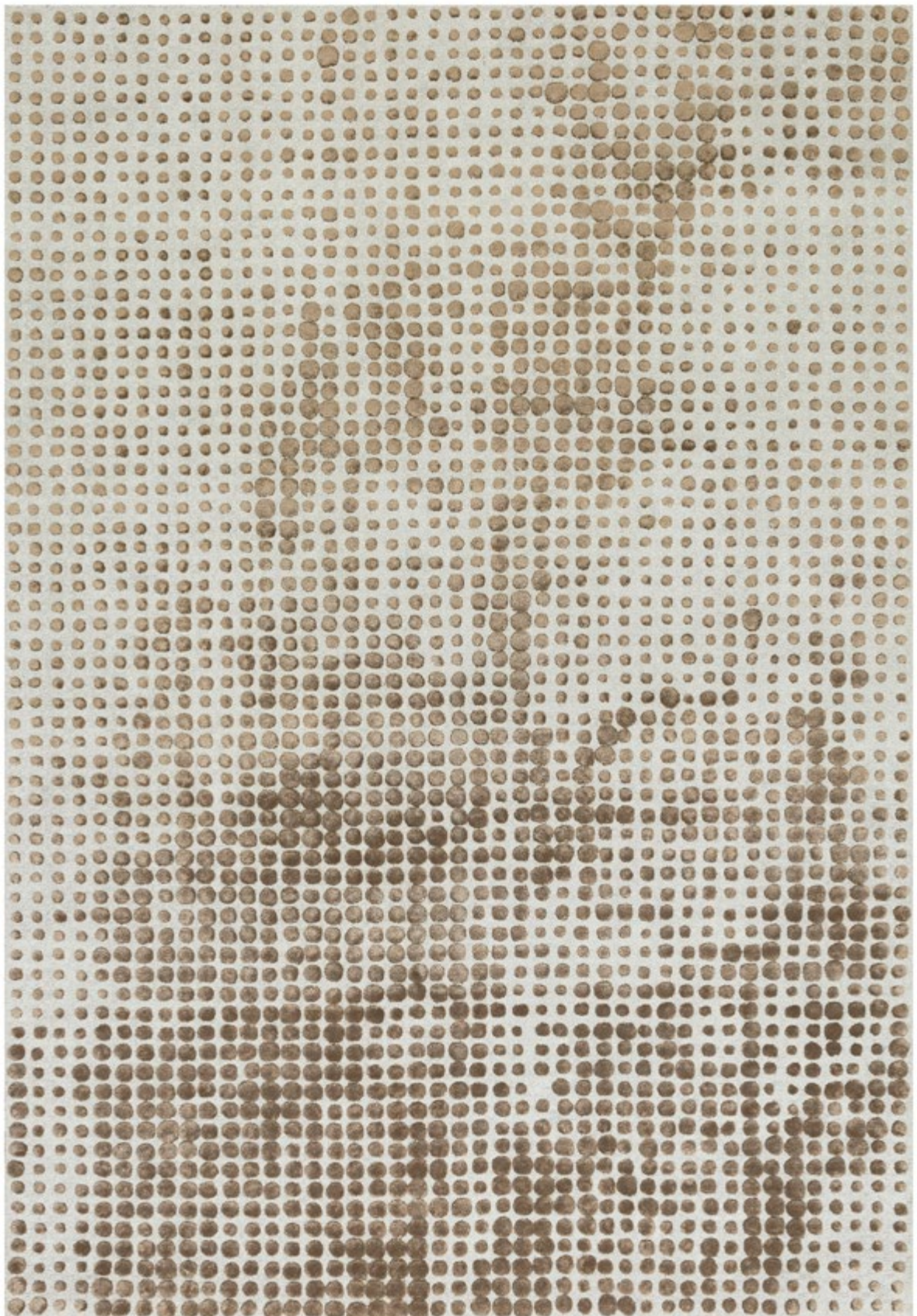

Light carpet / tappeto

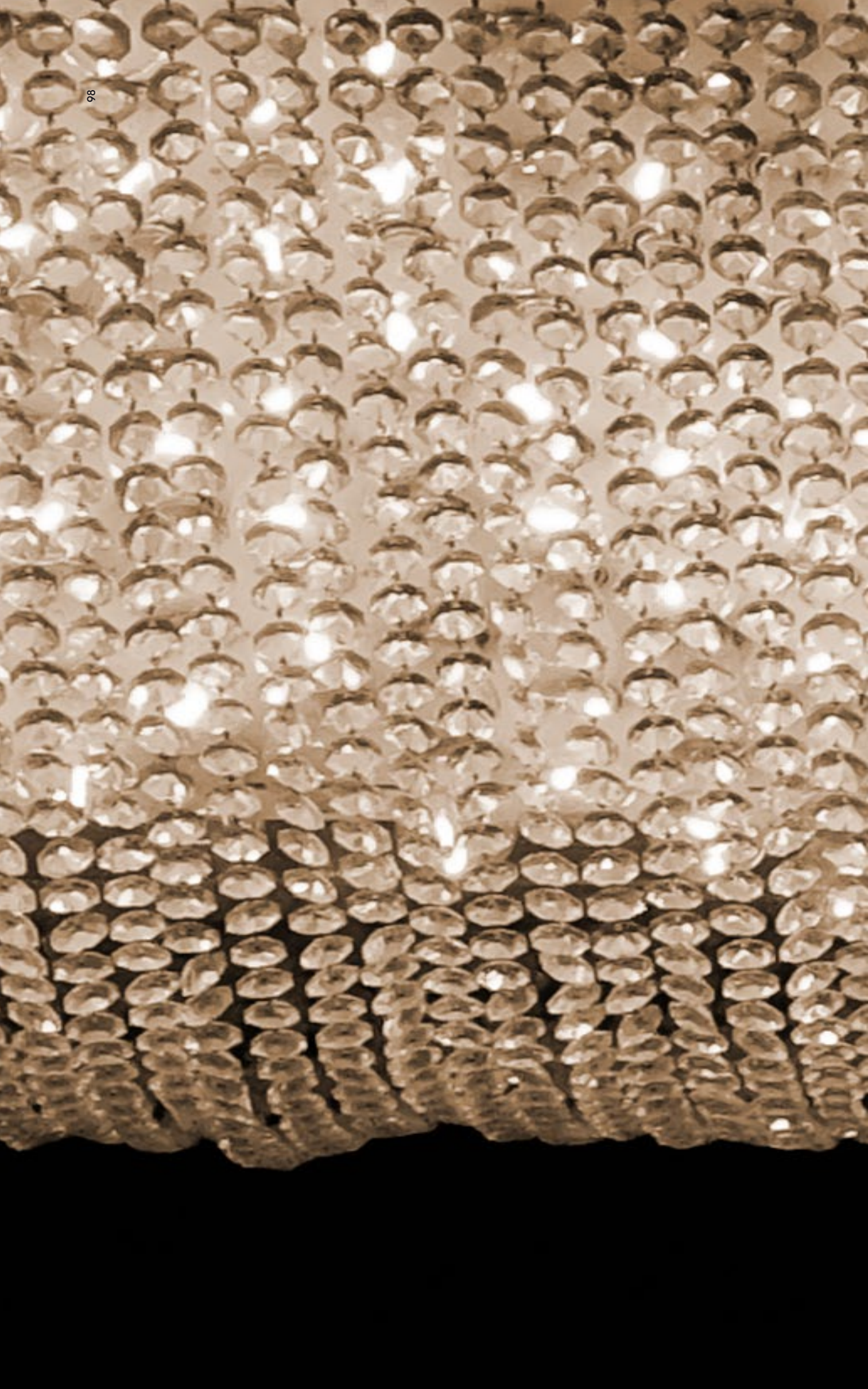

With its unique mix of elegant classic and contemporary architecture, the Quadrilatero is an area of Milan that particularly appeals to me. When I visited these four seemingly diverse buildings, I sensed a common thread, i.e. a sense of history that is interwoven with the way the city has evolved. Regardless of the differences in period and style, there is a certain continuity that expresses a Milan that remains faithful to its essence, even as the city itself continues to change.

Il quadrilatero è una zona di Milano che mi affascina particolarmente per il suo mix unico di eleganti architetture classiche e contemporanee. Visitando i quattro edifici, ho percepito un filo conduttore che unisce questi spazi così eterogenei: un senso di permanenza e di storia che si intreccia con l'evoluzione della città. Nonostante le differenze di epoca e stile, c'è una continuità che parla della Milano che cambia ma che rimane.



Skyline seating system / sistema di sedute

Chanterelle low tables / tavolini

Move rocking armchair / poltrona a dondolo

Otto poufs

Borealis screens / paraventi

Charlotte cabinet / contenitore

Amorfo, Hineri, Vanity vases / vasi

Floema plates / piatti

Beyond carpet / tappeto

Brun Fine Art & Antiques Gallery: pair of Chinese guardian lions in glazed ceramic; lost-wax bronze bull sculpture / coppia di cani di Pho in ceramica smaltata, Cina; scultura in bronzo e cera persa raffigurante toro



Chanterelle low tables / tavolini



Chanterelle low table / tavolino

Solemyidae sofas / divani

Chanterelle, Ray low tables / tavolini

Lady armchair / poltrona

Hikari bar cabinet

Liz-console console/ consolle

Summa pouf

Area tray / vassoio

Crystal Stone set of bar glasses, wine coolers and crystal bottles / set di bicchieri bar, glacette e bottiglie in cristallo

Inside vase / vaso

Moonshadow carpet / tappeto

Brun Fine Art & Antiques Gallery: *Cavallo e cavaliere*, polychromatic terracotta sculpture, Agenore Fabbri; gilded carved wood sculptures of Apollo and Zeus on a varnished base / scultura *Cavallo e cavaliere*, terracotta policroma, Agenore Fabbri; sculture in legno intagliato e dorato raffiguranti Apollo e Zeus, su base laccata.



Crystal Stone glasses / bicchieri

Bar Tender shaker



Liz-console console/ consolle Summa pouf

Brun Fine Art & Antiques Gallery, Agenore Fabbri: *Cavallo e Cavaliere*, polychromatic terracotta sculpture / *Cavallo e Cavaliere*, scultura in terracotta policroma



Liz-console console/ consolle

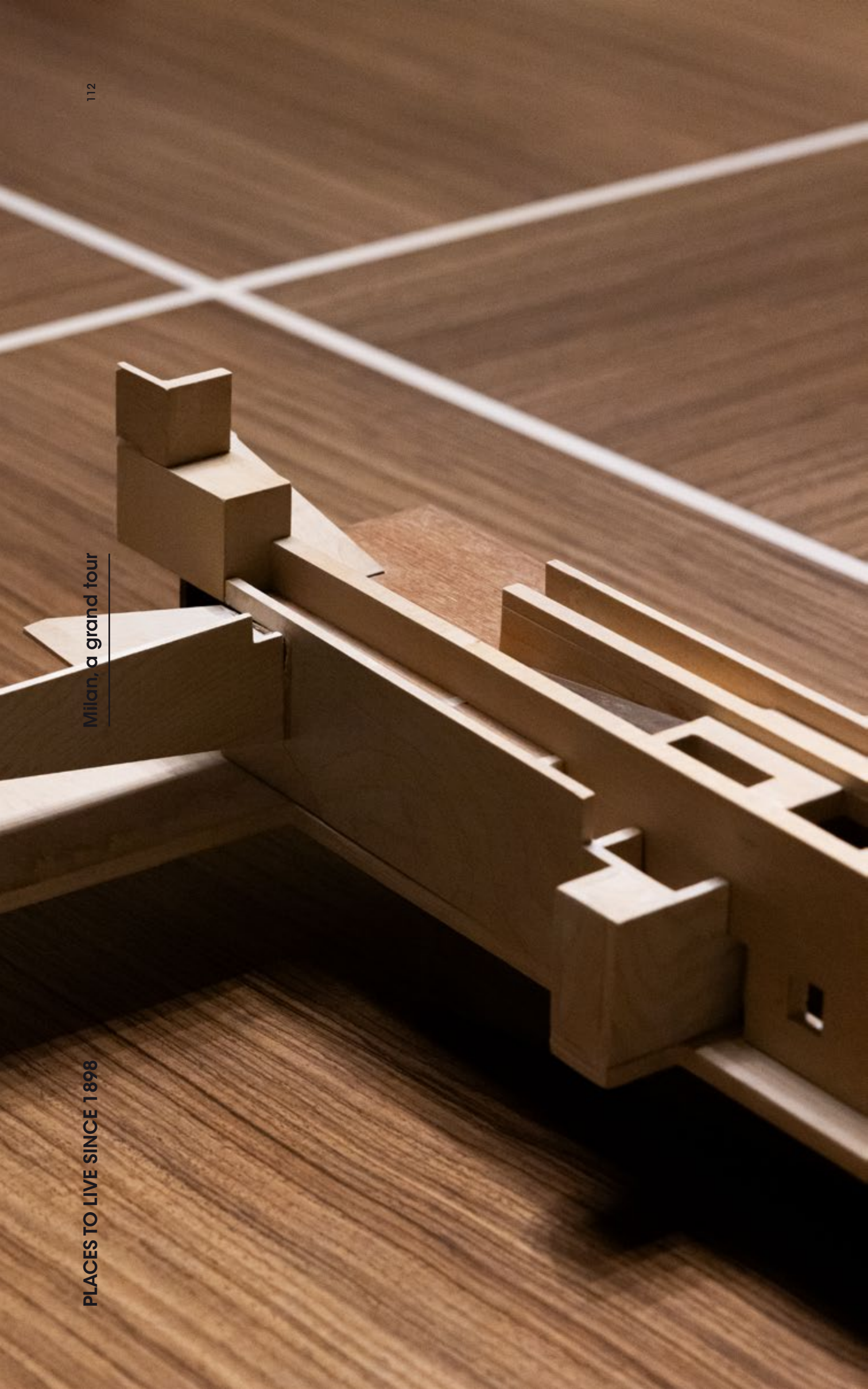

Here, fashion and design, tradition and innovation come together in an effortless dialogue against a backdrop of wonderful examples of Milanese nineteenth-century Modernist constructions whose essential lines and fine materials create a contemporary world that nevertheless retains the quality of a bygone age.

Qui, dove moda e design, tradizione e innovazione si incontrano e si parlano, sulla trama antica della città si innalzano opere del Novecento modernista milanese di grande valore, che con le loro linee pure e i loro materiali nobili vanno a creare un mondo contemporaneo con la qualità dell'antico.

Gordon table / tavolo

Calathea executive bergères / poltrone direzionali

Pietro Cascella: site-specific wall-hung and freestanding stone sculptures / sculture a parete e a terra site-specific, pietra



Gordon table / tavolo

Calathea executive bergère / poltrona direzionale



Calathea executive bergère / poltrona direzionale



Mistral table / tavolo

Plume chairs / sedie

Aei cabinets / contenitori

Area tray / vassoio

Crystal Stone set of bar glasses, wine coolers and crystal bottles /

set di bicchieri bar, glacette e bottiglie in cristallo

Brun Fine Art & Antiques Gallery: sculptural concrete base for a coffee table / base scultorea in calcestruzzo per tavolino





Plume chair / sedia



Milan, a grand tour



PLACES TO LIVE SINCE 1898

Plume chairs / sedie



Summa pouf



Soho seating system / sistema di seduta

Spark low table / tavolino

Summa pouf

Hikari sideboard / madia

Nastus vases / vasi

Brun Fine Art & Antiques Gallery: *Il Buon Pastore*, bronze sculpture on a marble base, Franco Lombardi; *Proposta*, Creole marble sculpture, Andrea Cascella / scultura *Il Buon Pastore*, bronzo su base marmo, Franco Lombardi; scultura *Proposta*, marmo creolo, Andrea Cascella



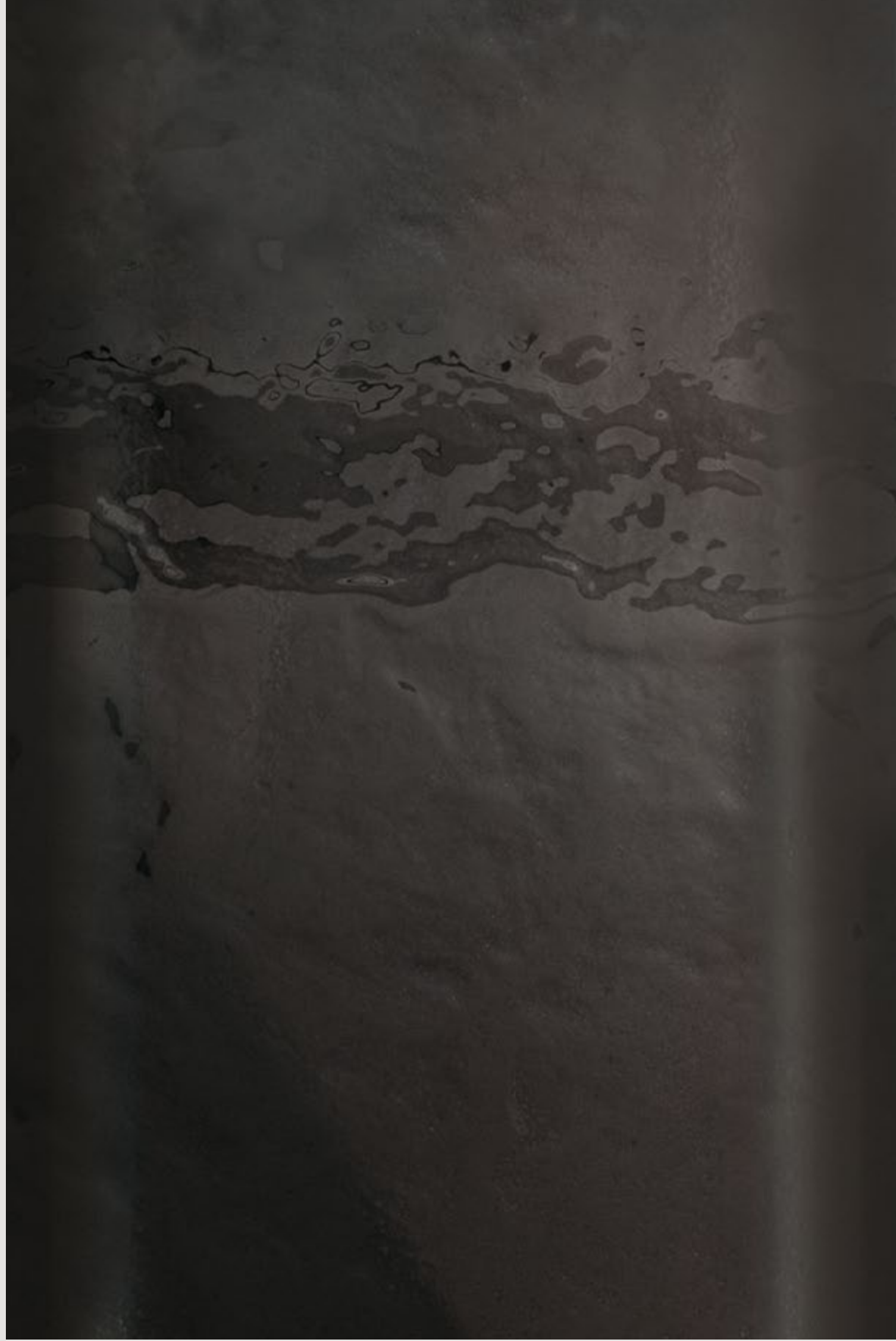

Behind the architecture itself, are the stories of its origins and the visionaries who conceived and believed in these extraordinary buildings that were destined to house art, theatre or businesses or indeed, simply to incite wonder and appreciation.

Dietro alle architetture ci sono le storie delle origini, di chi ha voluto e creduto in quelle "case gioiello", destinate ad accogliere l'arte, lo spettacolo, il commercio, o semplicemente a suscitare stupore e meraviglia.



Tenet writing desk / scrivania

Calathea executive bergère / poltrona direzionale

Town containers / contenitori

On Off lamp / lampada

Crystal Stone set of bar glasses, wine coolers and crystal bottles / set di bicchieri bar, glacette e bottiglie in cristallo

Bar Tender shaker

Frequence carpet / tappeto

Brun Fine Art & Antiques Gallery: seated Asian figure in painted terracotta; bronze medallion with the faces of a man and a woman against a floral background / figura in terracotta dipinta raffigurante personaggio orientale assiso; medaglione in bronzo raffigurante volti di uomo e donna su sfondo floreale



Swing armchairs / poltrone Ghiblim low table / tavolino Upward lamp / lampada
Bubbles vases / vasi Flora glazed ceramic flowers / fiori in ceramica smaltata
Modular carpet / tappeto

Brun Fine Art & Antiques Gallery, Sirio Tofanari: bronze gazelle sculpture / scultura in bronzo raffigurante gazella



Flora glazed ceramic flowers / fiori in ceramica smaltata

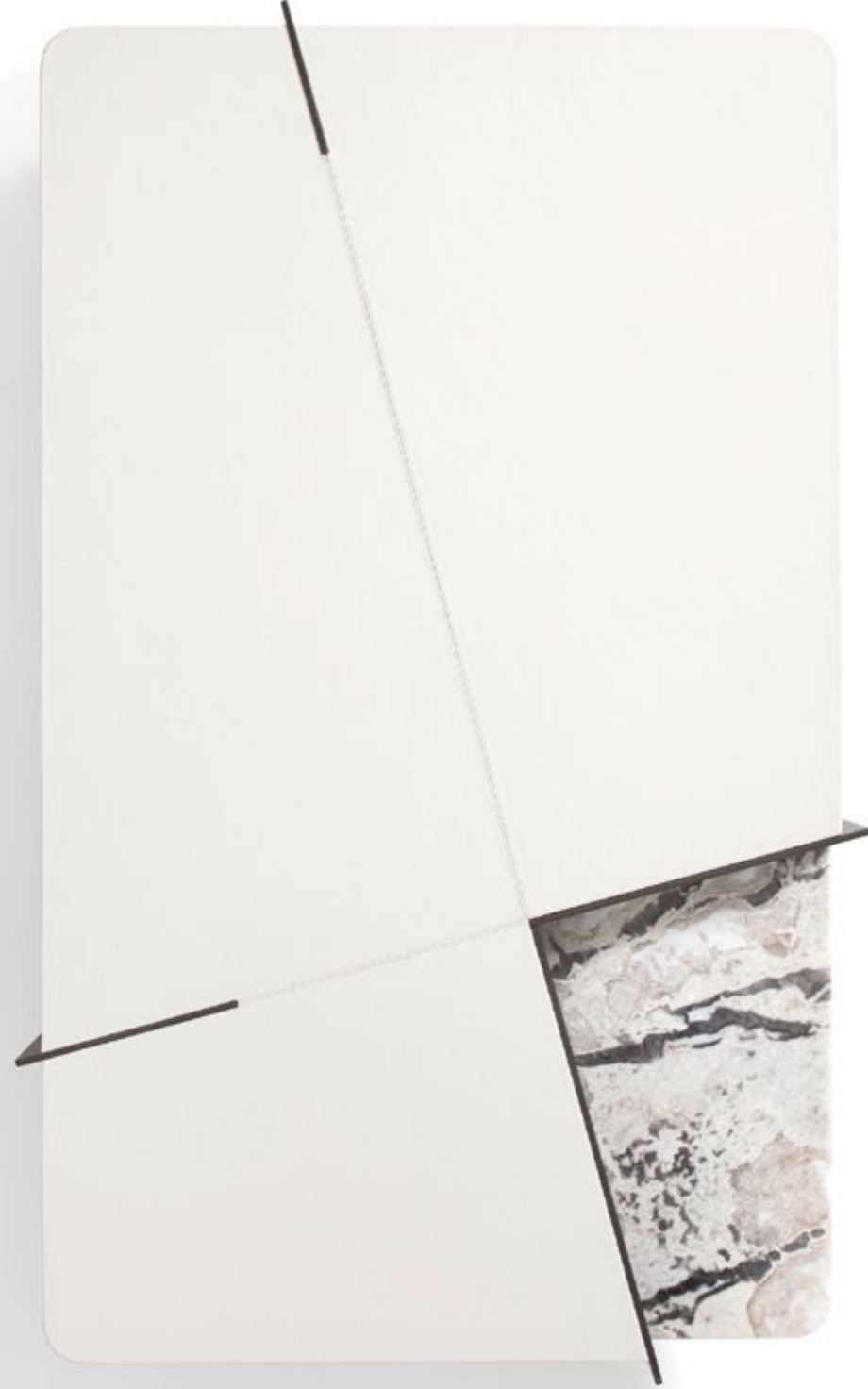

Ghiblim low table / tavolino





Vesper seating system / sistema di seduta

Progetti Fashion small armchair / poltroncina

Griffe low table / tavolino

Mistral table / tavolo

Libra lamp / lampada

Liling carpet / tappeto

Brun Fine Art & Antiques Gallery, Andrea Cascella: *Studio per un'altra estate*, limestone sculpture; *Untitled*, Rock Crystal sculpture / *Studio per un'altra estate*, scultura in pietra calcarea
Senza Titolo, quarzo Rock Crystal

Brun Fine Art & Antiques Gallery, Pietro Melandri: glazed ceramic vase / vaso in ceramica smaltata







Libra lamp / lampada



Mistral table / tavolo **Ibla** chairs / sedie **Amiral** bookcase / libreria **Water** lamps / lampade **Tube** vases / vasi

Brun Fine Art & Antiques Gallery: fish sculpture in bronze, Sirio Tofanari; fluted column in white marble with a bust of a woman in white marble, Giovacchino Fortini / scultura in bronzo raffigurante pesci, Sirio Tofanari; colonna scanalata in marmo bianco con busto muliebre in marmo bianco, Giovacchino Fortini



ibla chair / sedia





PAC is among the very first examples in Italy of architecture designed to host contemporary art. Conceived as a versatile exhibition structure with fluid, wall-less spaces, which was considered highly innovative at the time, it also introduced other original features such as the continuity between the natural and the artificial, and between art and nature.

Il PAC è tra i primi esempi in Italia di architettura progettata per l'arte contemporanea e pensata come un'agile struttura espositiva, con spazi fluidi privi di pareti divisorie, un'innovazione per l'epoca, come originale è la continuità tra il naturale e l'artificiale, tra arte e natura, grazie alla vetrata che si affaccia sui giardini di Villa Reale.





Scirocco sideboard / madia

Brun Fine Art & Antiques Gallery, Andrea Cascella: *Stillness*, portoro marble sculpture / *Stillness*, marmo Portovenere scultura



Karphi seating system / sistema di seduta

Chanterelle, Scaleno low tables / tavolini

Scirocco sideboard / madia

Bond separating elements / elementi separatori

Water lamps / lampade

Bubbles, Nastus vases / vasi

Sataria carpet / tappeto

Brun Fine Art & Antiques Gallery, Andrea Cascella: *Stillness*, portoro marble sculpture; *Tutto grigio*, marble sculpture / *Stillness*, marmo Portovenere scultura; *Tutto grigio*, marmo Blue Turquin



Mistral table / tavolo Amiral bookcase / libreria Lazy Susan revolving tray / vassoio girevole
Floema plates / piatti Crystal Stone set of bar glasses, wine coolers and crystal bottles /
set di bicchieri bar, glacette e bottiglie in cristallo Water lamps / lampade





Debut at the Academy

Valle Giulia

ROMA 2023

EN ____ Between Villa Borghese and the Parioli district in Rome, there's a place where art, architecture, nationalities and lands coexist: Valle Giulia. Here, the prestigious cultural institutes of nine nations are clustered, each one just a few hundred meters from the next. Discovering this secluded place, unknown even to locals, and its buildings, small gems of art and cosmopolitan culture, happened by chance. And, as often happens with the unexpected, it has proven to be fortuitous.

IT ____ Tra Villa Borghese e i Parioli esiste un luogo in cui arte, architettura, popoli e geografie coesistono: Valle Giulia. Qui sono concentrati i prestigiosi istituti culturali di ben nove nazioni, tutti a poche centinaia di metri l'uno dall'altro. L'incontro con questo luogo, isolato e segreto agli stessi romani, e le sue architetture, piccole gemme di arte e cultura cosmopolita, è avvenuto per caso e, come spesso succede con l'inaspettato, si è rivelato un incontro felice.



Karphi seating system / sistema di seduta

Eva bergère, pouf

Athene Scaleno low tables / tavolini

Amorfo, Harria vases / vasi

Frequence carpet / tappeto

Brun Fine Art Gallery, Pho dogs in glazed ceramic, and brush holders in carved wood / cani di Pho in ceramica smaltata e portapennelli in legno intagliato



Karphi seating system / sistema di seduta

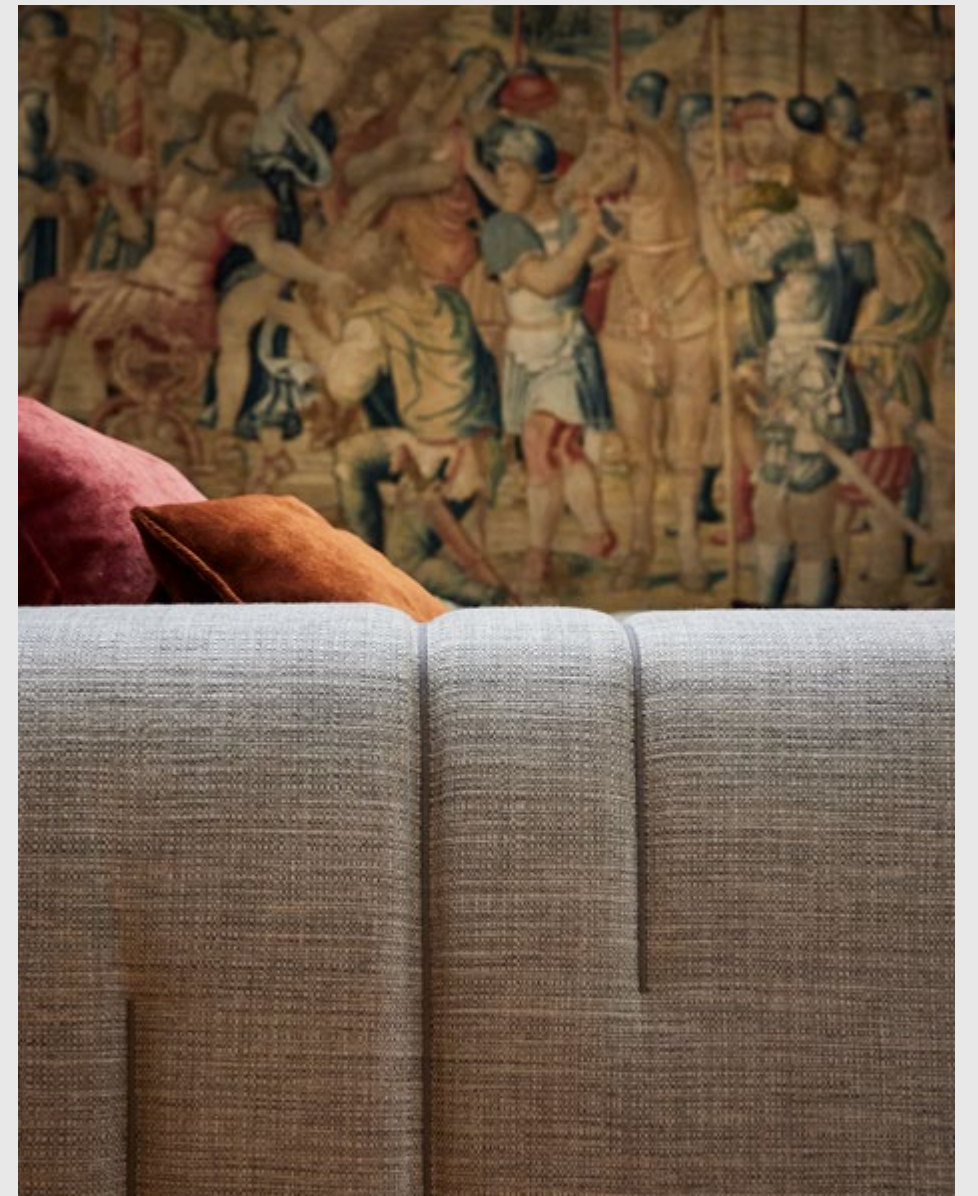



A visual storytelling in a peaceful, solitary road of Rome surrounded by greenery where three academic foundations (the Academia Belgica, the Royal Netherlands Institute and the Danish Academy) stand out among the others, twentieth-century buildings that are as prestigious as the institutes within.

Un racconto visivo, in una via tranquilla e solitaria di Roma, stradina immersa nel verde, dove si affacciano, tra le altre, tre fondazioni accademiche - l'Accademia Belgica, il Reale Istituto Neerlandese e l'Accademia di Danimarca - ospitate in edifici novecenteschi di grande valore.

G-Code Table table / tavolo

Hero chairs / sedie

Nastus vase and bowls / vasi e ciotole

Floema plates / piatti





Valle Giulia

PLACES TO LIVE SINCE 1898





Hero chairs / sedie

G-Code Table table / tavolo

Hero chairs / sedie



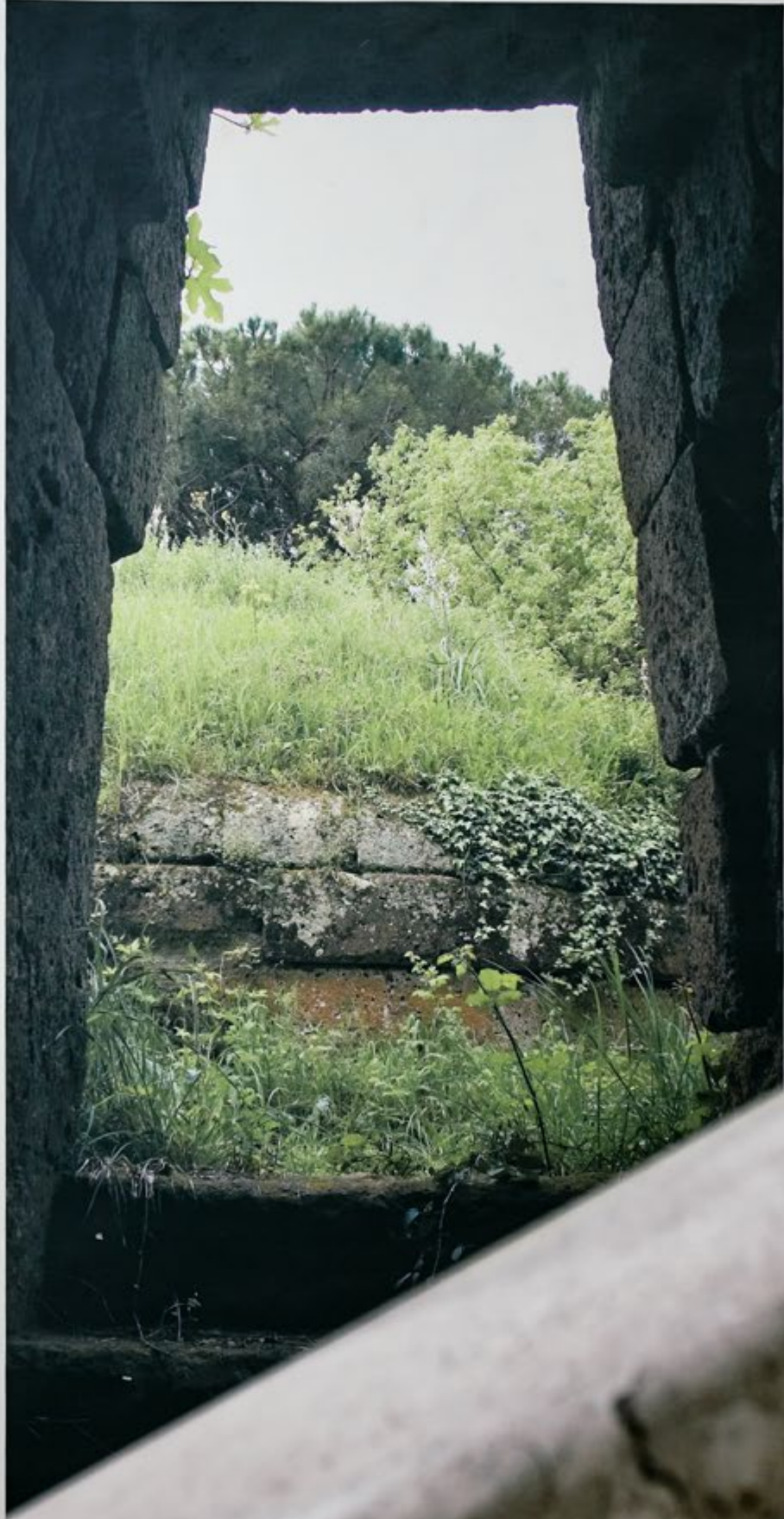

Here, nature, with her Italian gardens guarded over by porticos and terraces of Pontian memory, receives us, responding to the idea of hospitality and inclusion that inspired and sparked the birth of the academies themselves, veritable cultural ambassadors in a foreign land.

Qui la natura, con i suoi giardini all'italiana su cui si affacciano portici e terrazze di pontiana memoria, accoglie, rispondendo all'idea di ospitalità e inclusione che ha ispirato e suggerito la nascita delle stesse Accademie, veri e propri Ambasciatori culturali in terra straniera.

Tie XL armchair / poltrona Spark coffee tables / tavolini Kukei sideboard / madia Amazonia sculptures / sculture Floema plates / piatti Vanity vases / vasi
Diy mosaic puzzle Area trays / vassoi
 Brun Fine Art Gallery, bronze Guanyin head / testa Guanyin in bronzo



Tie XL armchair / poltrona
Area tray / vassoio

Spark coffee tables / tavolini

Diy mosaic puzzle



Tie XL armchair / poltrona

Valle Giulia

PLACES TO LIVE SINCE 1898



Kukei sideboard / madia

Floema plates / piatti

Vanity vases / vasi

Diy mosaic puzzle

Brun Fine Art Gallery, bronze Guanyin head / testa Guanyin in bronzo

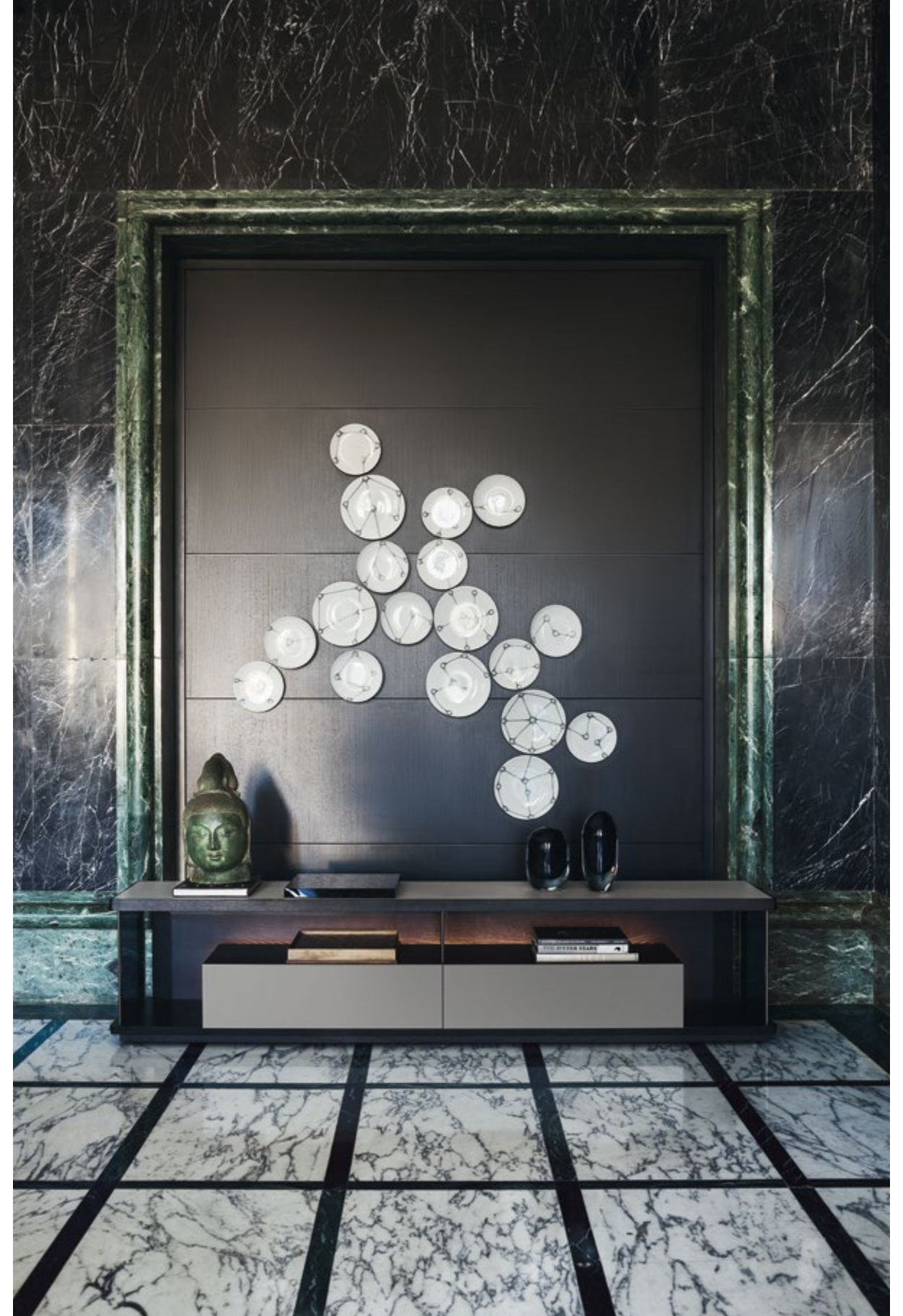

PLACES TO LIVE SINCE 1898

Valle Giulia



Altea bed / letto Morfeo bedside table / comodino Domus system / sistema Progetti armchair / poltrona
New Kendama, Swords lamps / lampade Whisper carpet / tappeto
 Gallery Brun Fine Art, vestal metal alloy / vestale, lega metallica
 Giulio Romano, *I Generali incoronati*, Accademia Belgica, Rome, tapestry / arazzo





Progetti armchair / poltrona

Griffe coffee table / tavolino

Domus system / sistema

Gallery Brun Fine Art, vestal metal alloy / vestale, lega metallica

Giulio Romano, *I Generali incoronati*, tapestry, Academia Belgica, Rome /

Giulio Romano, *I Generali incoronati*, Academia Belgica, Rome, tapestry / arazzo



“Valle Giulia was the silent inspiration of my imagination. The colours and fine materials of the Academia Belgica, with its magnificent library and entry, striking enough to take your breath away on their own; the grand view of the garden of the Royal Netherlands Institute, with the intimate, secret air of a private villa; the infinite creative departure points offered by the Danish Academy, with its enchanting, frozen-in-time library.

Worlds that are different yet equal when it comes to the contemplation of so much beauty.”

“Valle Giulia è stata l’ispiratrice silenziosa della mia immaginazione.

I colori e i materiali nobili dell’Academia Belgica, con la sua libreria e il suo ingresso magnifici, di per sé scenografie da togliere il fiato; il grandioso affaccio sul parco del Reale Istituto Neerlandese, con la sua aria intima segreta da villa privata; gli infiniti spunti creativi suggeriti dall’Accademia di Danimarca, con la sua incantevole biblioteca sospesa nel tempo. Mondi diversi eppure uguali davanti alla contemplazione di tanta bellezza.”

- FEDERICO CEDRONE -





Mizar table special version / tavolo, versione speciale
Gallery Brun Fine Art, terracotta vase / vaso terracotta

Norah chairs / sedie

Anthology boiserie

Modular carpet/ tappeto



Norah chairs / sedie



Mizar table / tavolo

Modular carpet/ tappeto



Drive sofa / divano All Around armchairs / poltrone Mia low tables / tavolini Woody pouf and side-table / pouf e tavolin Borealis screen / paravento
Clina vase / vaso Liling carpet / tappeto

Gallery Brun Fine Art, Claudio Zauli, vase, polychrome ceramics, and stoneware clod / vaso in ceramica policroma e zolla in gres

Marble statues, Royal Netherlands Institute, Rome / statue in marmo, Reale Istituto Neerlandese, Roma



The fine materials, the clean, rigorous aesthetics of the different architectural styles: Rationalism for the Accademia Belgica, Neoclassicism and Renaissance Revival for the Royal Netherlands Institute and Functionalism for the Danish Academy.

All designed to highlight the identity and role of the places.

I materiali di pregio, la pulizia e il rigore dei diversi stili architettonici: Razionalismo per l'Accademia Belgica, Classicismo e Neorinascimento per il Reale Istituto Neerlandese, Funzionalismo per l'Accademia di Danimarca.

Tutti volti a sottolineare l'identità e la funzione dei luoghi.

Mia low tables / tavolini

Woody pouf and side-table / pouf e tavolini

Clina vases / vasi

Liling carpet / tappeto





Calathea armchair / poltroncina

Borealis paravento / screen

Martin Rous, oil on canvas, Royal Netherlands Institute, Rome / olio su tela, Reale Istituto Neerlandese, Roma



Nature and art, the kind that you see but also the kind that you soak up via the history of a place and in the passing of time. Tangible beauty, a gift from the heavens and from man, in perfect harmony.

Natura e arte, quella che si vede ma anche che si respira nella storia del luogo e nel flusso del tempo. Bellezze tangibili, dono del cielo e dell'uomo, in perfetta armonia.



Valle Giulia



PLACES TO LIVE SINCE 1898

Woody pouf and side-table / pouf e tavolini

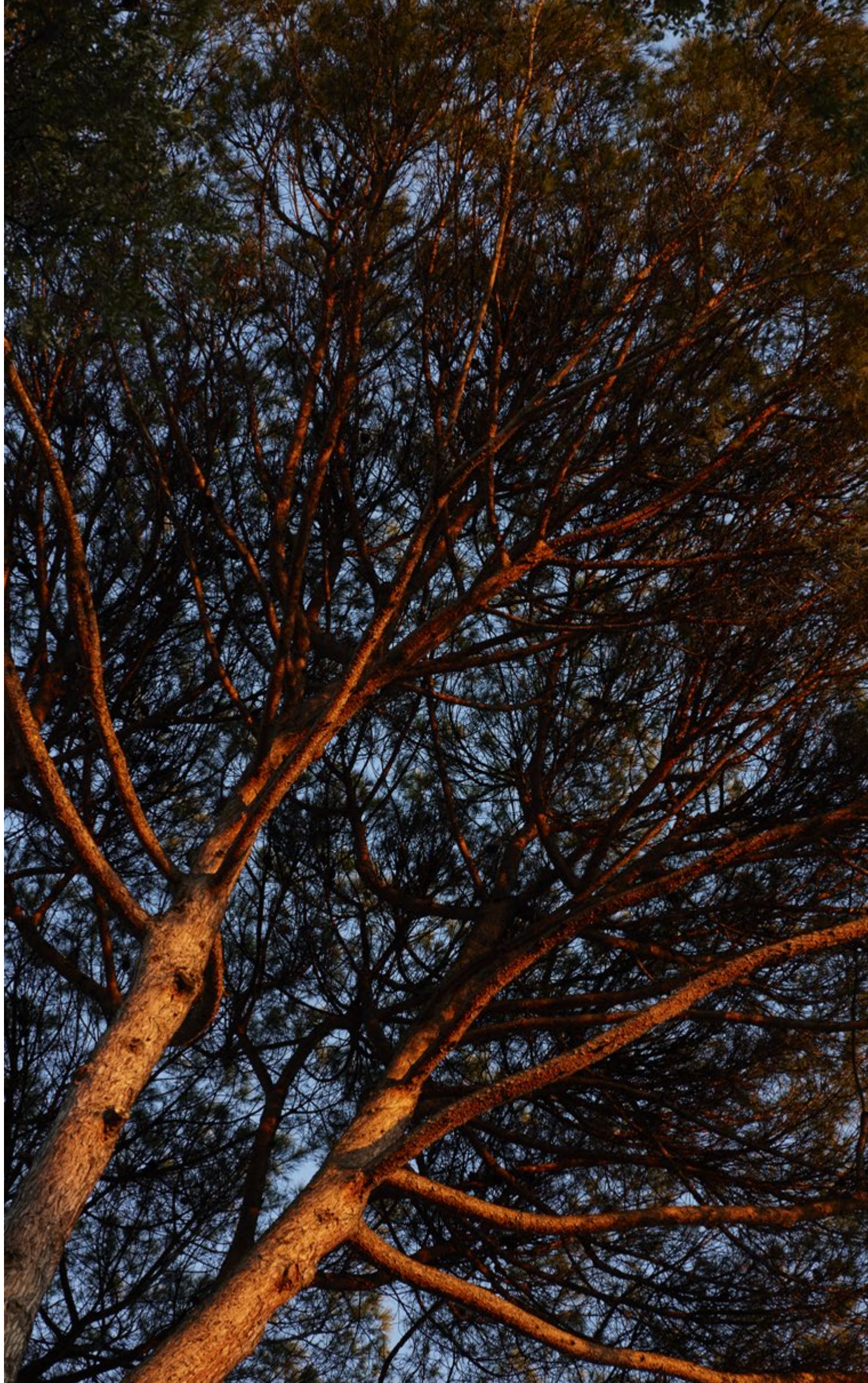

Gea low table / tavolino

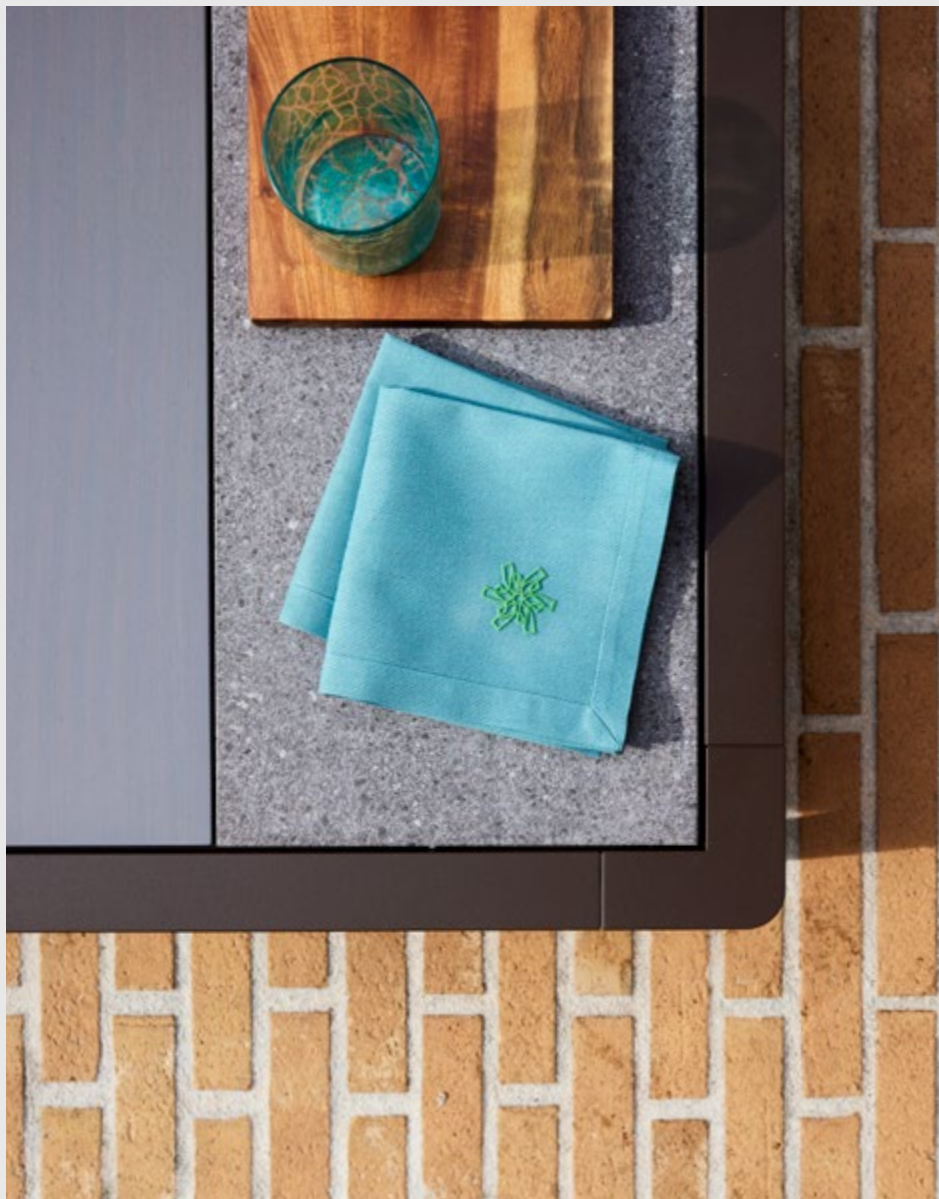

Gea sun bed and rocking small armchair / lettino e poltroncina a dondolo

Gea, Apsara low tables / tavolini Gea candle holders / porta candele

Sys hindsbo, *Man with anxious dog*, marble, Danish Academy, Rome / *Uomo con cane ansioso*, marmo, Accademia di Danimarca, Roma



Skirt stools / sgabelli Harria, Hineri vases / vasi Leggio lectern / reggilibro Club portasigari / cigar box
 Leif Kath, *Senza titolo*, 2008



Skirt stool / sgabello





Calathea executive swivel armchair / poltrona direzionale girevole

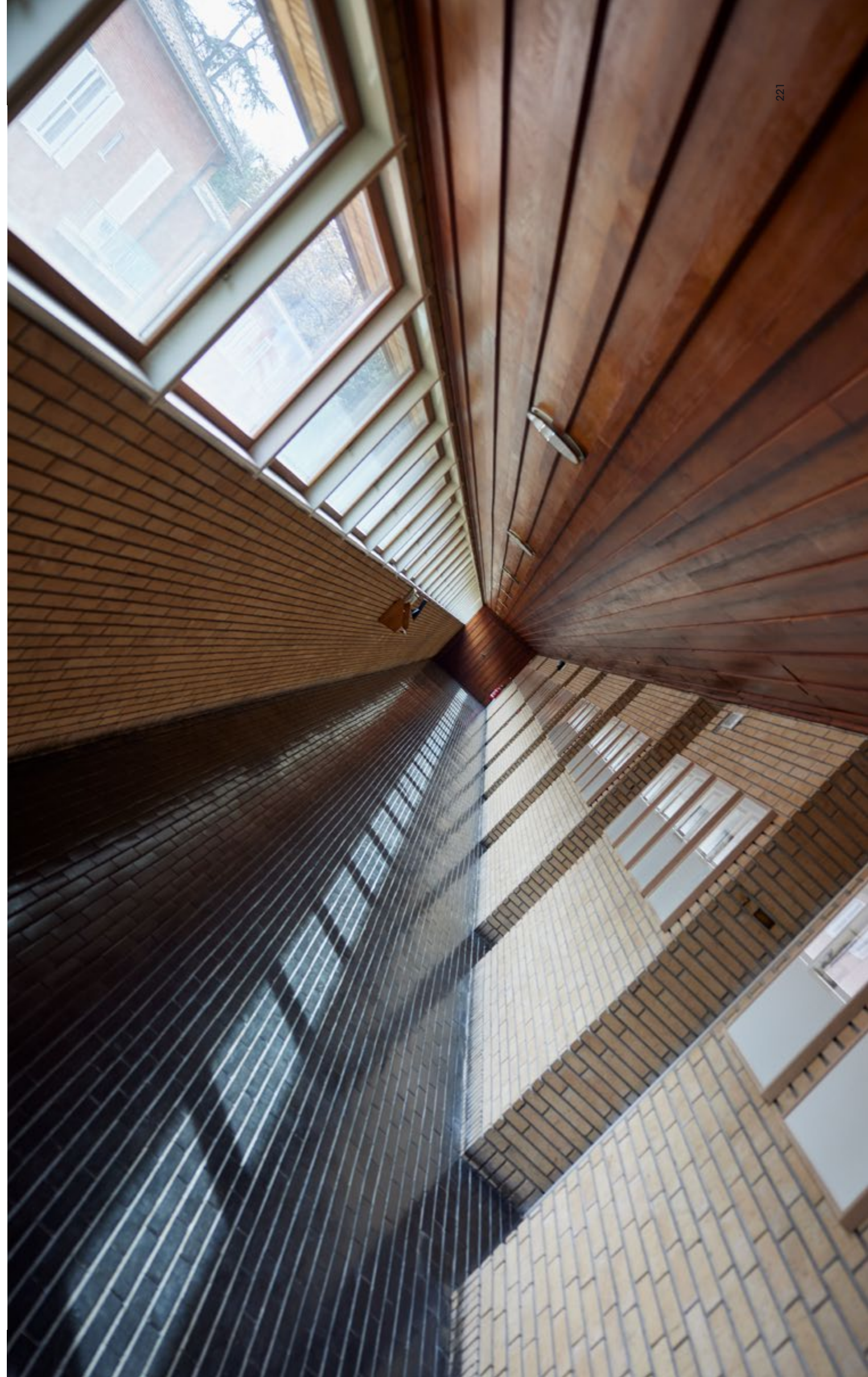

G-Code Desk desk /scrivania

Calathea executive swivel armchair / poltrona direzionale girevole

Urban seating system / sistema di seduta

Round, low tables / tavolini

Harria, Bubbles vases /vasi

Spazio Tempo table lamp / lampada da tavolo

Sataria carpet / tappeto



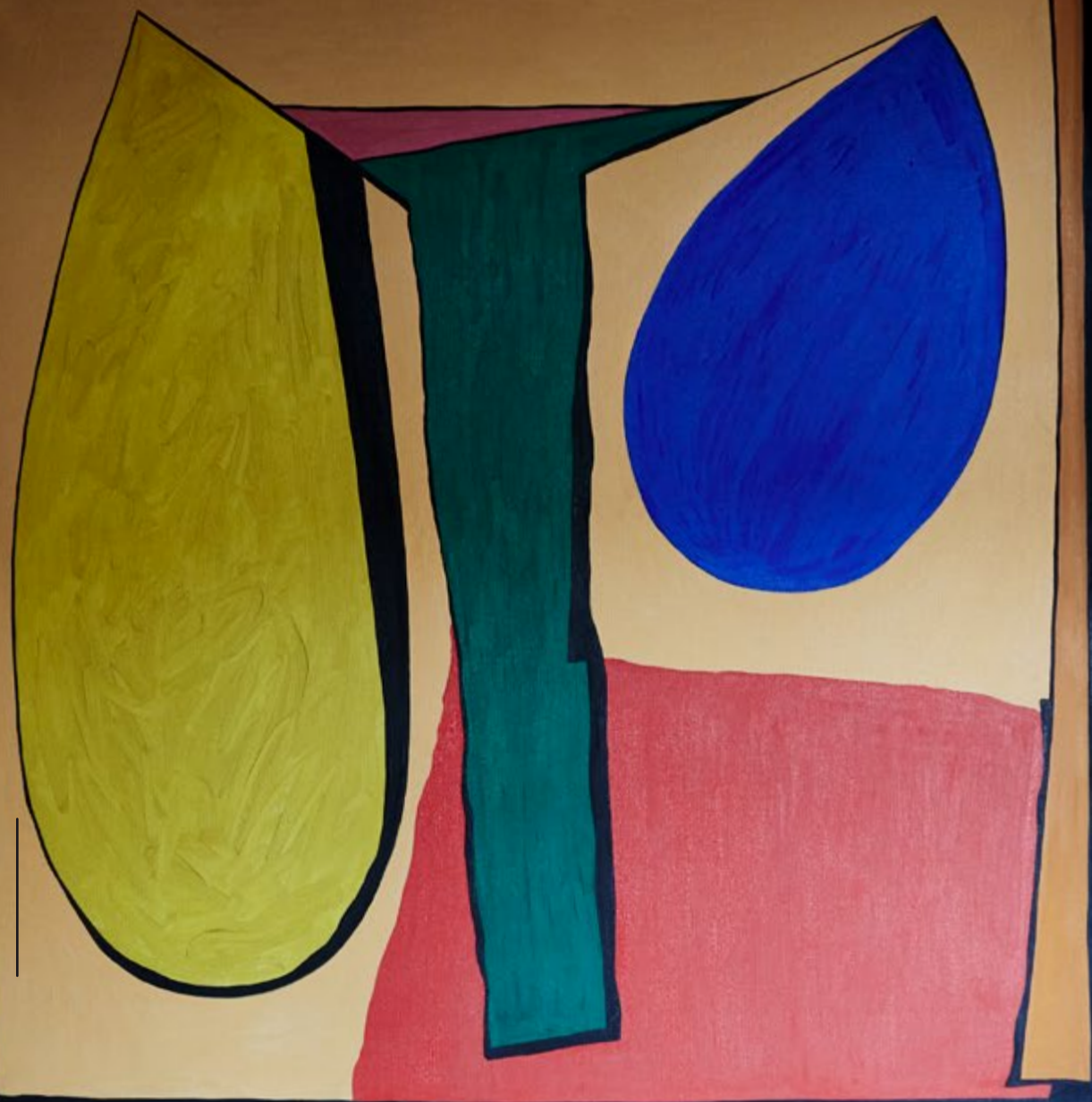

Within the spaces of these structures, we've imagined domestic and familiar settings where the Giorgetti lifestyle intermingles with the architectural references and cultural and artistic atmospheres of different lands and eras, all of which share a Mediterranean genius loci, made of the sky, colours, and aromas.

Dentro gli spazi di queste architetture, abbiamo immaginato ambienti domestici e familiari dove lo spirito dell'abitare Giorgetti si mescola ai riferimenti architettonici e alle atmosfere culturali e artistiche di geografie ed epoche diverse ma accomunate dal genius loci mediterraneo - fatto di cielo, colori, profumi.

Griffe low table / tavolino Ripple small armchairs / poltroncine Vanity vases /vasi
Richard Mortensen, *Lettere postume a Clara Jensen*, 1970





Opus armchair / poltrona

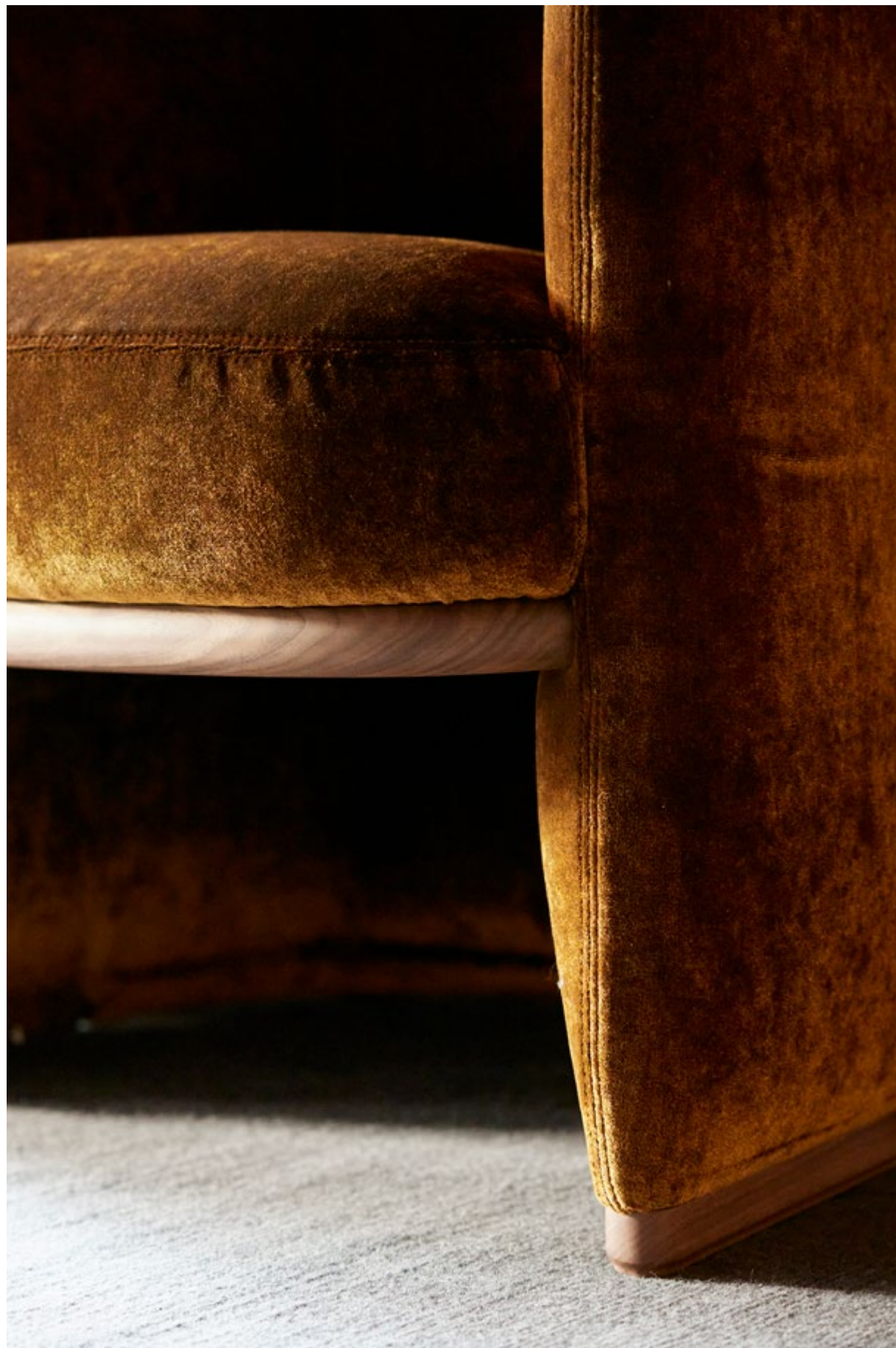

Opus armchairs / poltrone
Niels Guttormsen, iron sculpture, Danish Academy, Rome

Spark coffee table with chessboard inlay / tavolino con intarsio a scacchiera
Niels Guttormsen, iron sculpture, Danish Academy, Rome

Summa pouf

On Off lamp / lampada

Cross Over carpet / tappeto





Brun Fine Art Gallery, Bronze seated figure, Japan / figura seduta, bronzo, Giappone







Aldia table and chairs / tavolo e sedie **Nisida** carpet and pillows / tappeto e cuscini
 Gallery Brun Fine Art, plaster heads / teste di gesso

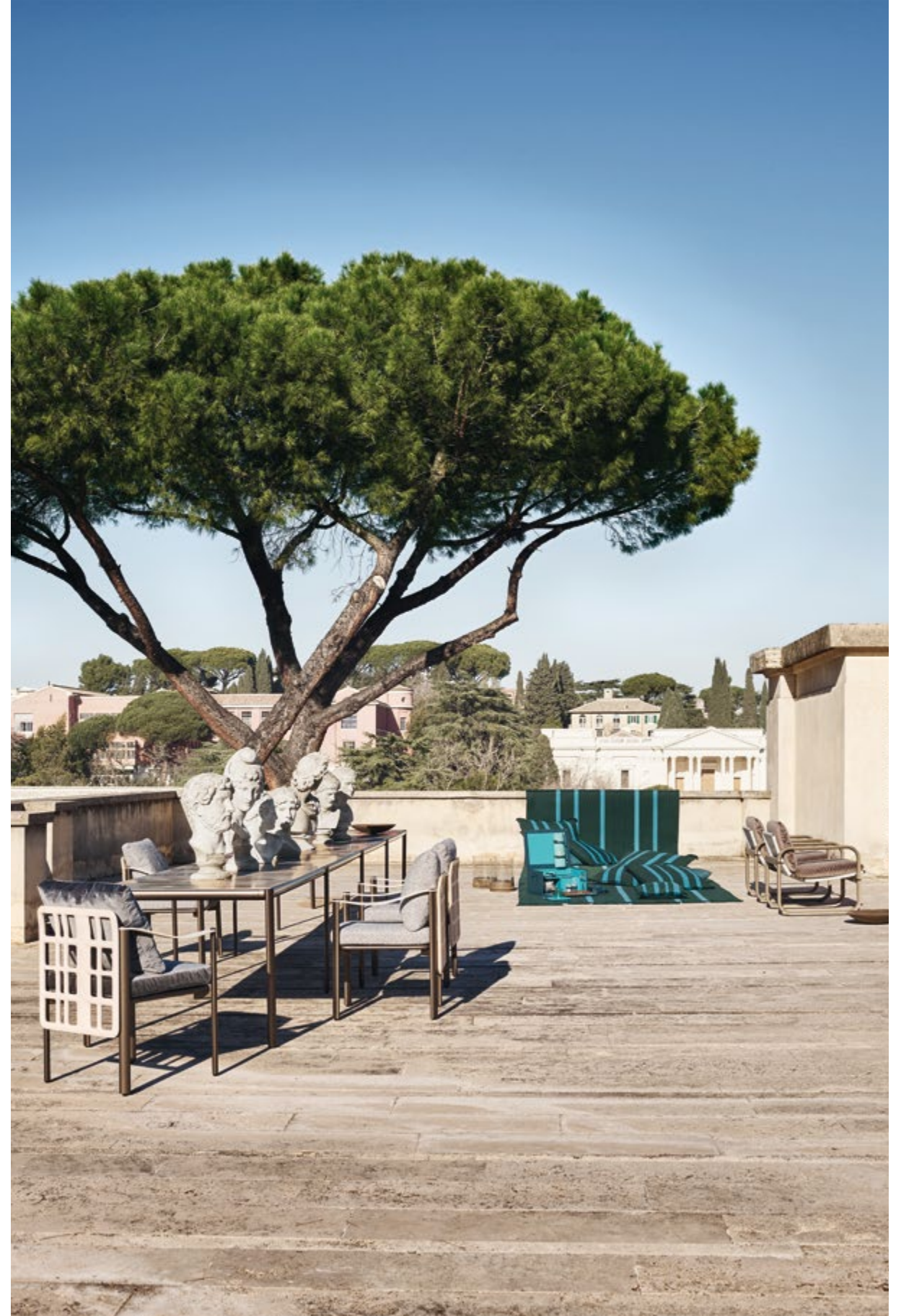



Nisida carpet and pillows

Gea candle holders / porta candele

Floema plates / piatti

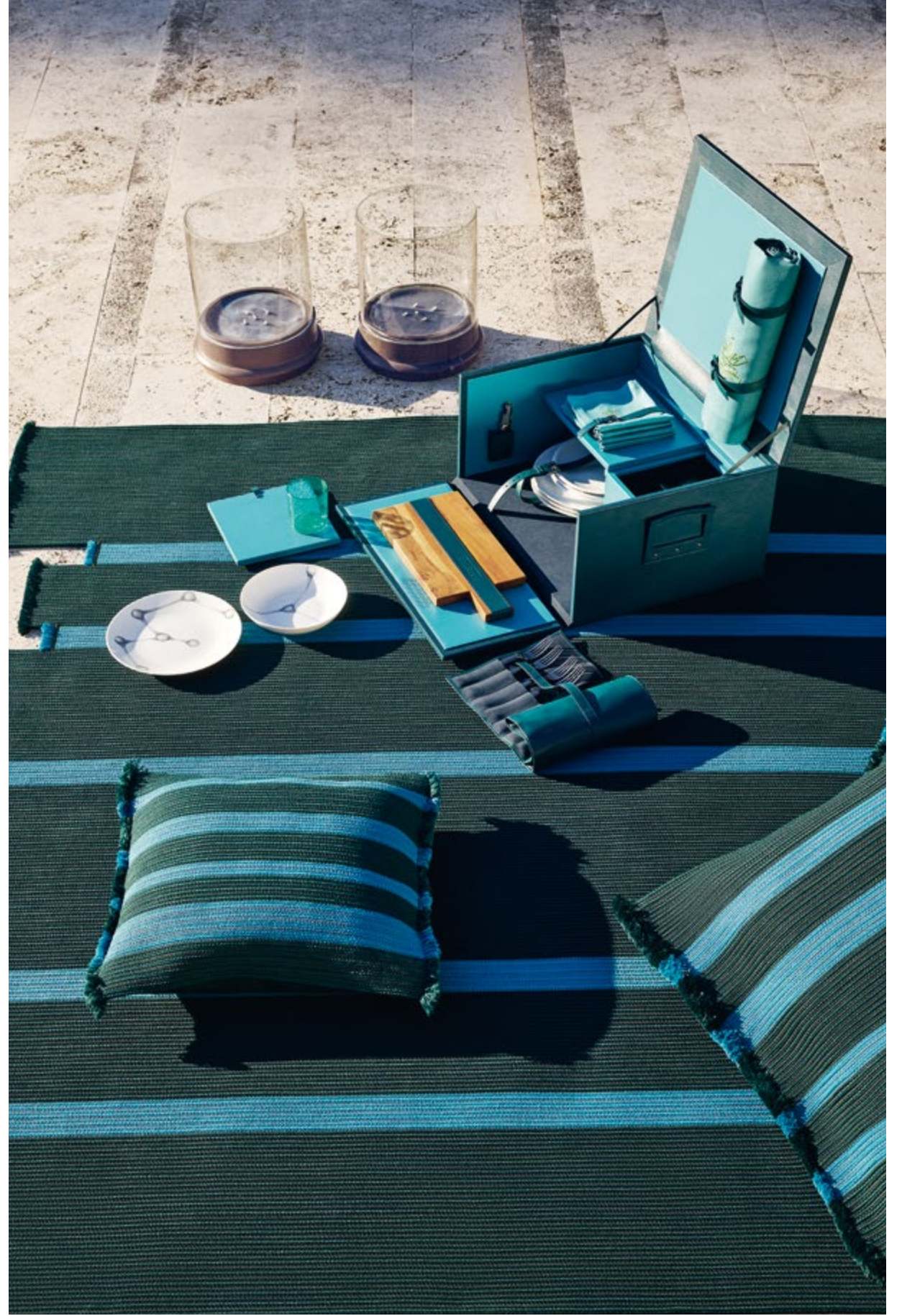



G-Code Console console / consolle **Hero** small armchair / poltroncina **Fit** low table / tavolino **Bubbles** vases / vasi **Breeze** carpet / tappeto
 Søren Georg Jensen, *Aurora Septentrionalis*, Danish Academy, Rome / *Aurora Septentrionalis*, Accademia di Danimarca, Roma





Janet armchair / poltrona Kukei sideboard / madia Shighera carpet / tappeto
Kaspar Bonnén, *Where?*, Danish Academy, Rome / Accademia di Danimarca, Roma



Kukei sideboard / madia Shighera carpet / tappeto
Kaspar Bonnén, *Where?*, Danish Academy, Rome / Accademia di Danimarca, Roma



A small oasis from the late 1930s

Castrocaro Terme

CASTROCARO 2022

- EN** — Finding the Castrocaro Terme spa was fortuitous. All of its rooms share exuberant materials and iconographic narration (play and leisure) and even geometric rigour in their forms (solemnity and austerity), a world that balances sense and sensibility, the identifying impulses of Italian architecture and decoration in the late Deco period, one of the golden ages of our artistic heritage.
Being in these spaces today means living or re-living the evocative, thrilling settings of the era, because everything is still as it once was.
- IT** — Castrocaro Terme è stato un incontro felice. Tutti gli spazi hanno in comune l'esuberanza dei materiali e delle narrazioni iconografiche (gioco e svago) come il rigore geometrico delle forme (solennità e sobrietà), un mondo in equilibrio tra sentimento e ragione, pulsioni identitarie della cultura architettonica e decorativa italiana del periodo tardo déco, tra le golden age della nostra storia artistica.
Abitare questi spazi, oggi, significa vivere o rivivere le situazioni emotive e suggestive dell'epoca, perché tutto è rimasto e mantenuto com'era.



Soho seating system / sistema di seduta Domus system / sistema Anthology boiserie
Montecarlo poker box Sataria carpet / tappeto
Oblong Gallery, *Balancing on the past*, Stefano Bombardieri, sculpture / scultura



Soho seating system / sistema di seduta Griffe low tables / tavolini Domus system / sistema Anthology boiserie Montecarlo poker box Amorfo, Hineri vases / vasi
Diy mosaic puzzle Sataria carpet / tappeto
 Oblong Gallery, *Balancing on the past*, Stefano Bombardieri, sculpture / scultura





Soho seating system / sistema di seduta

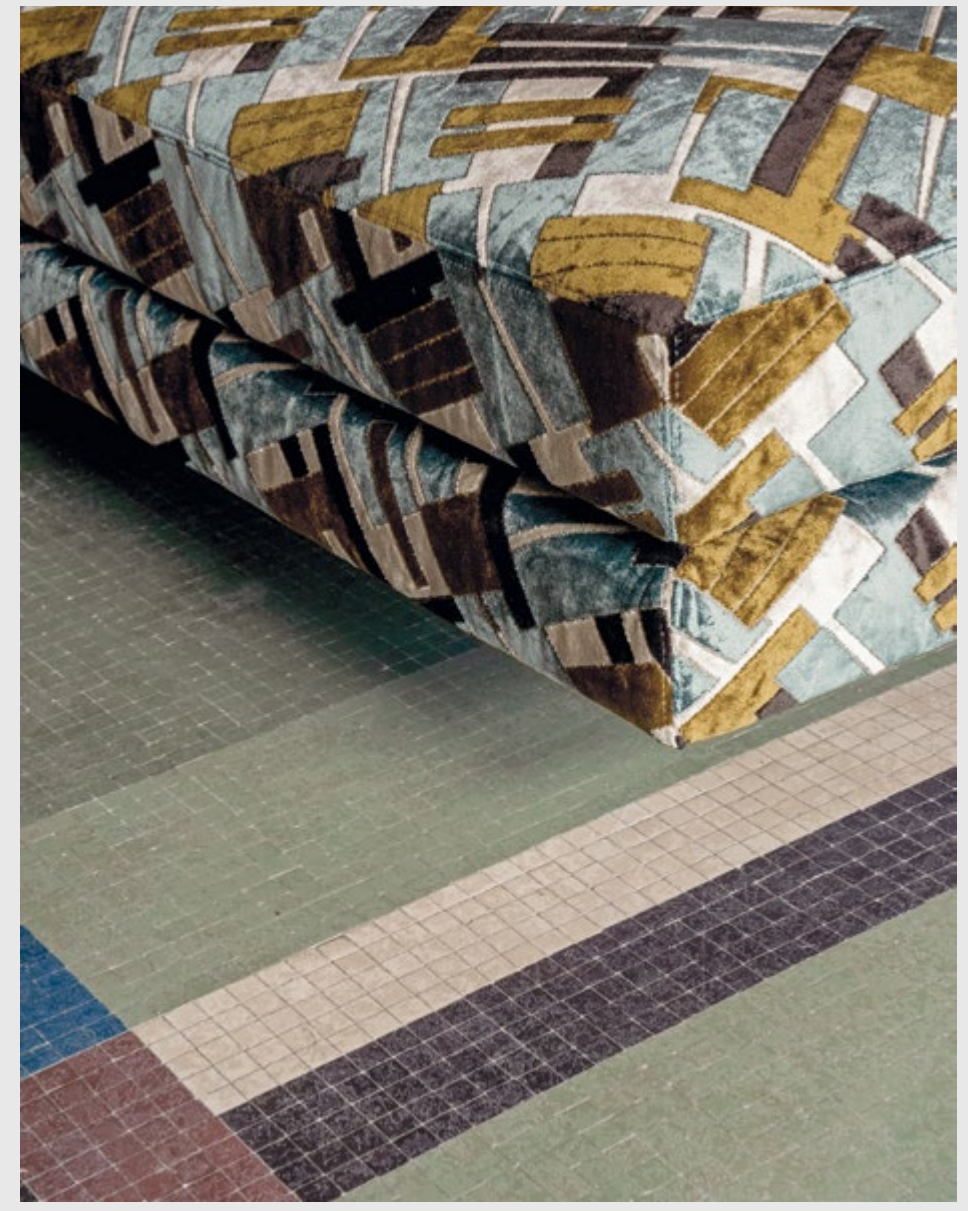



Soho seating system / sistema di seduta
Sataria carpet / tappeto

Griffe low table / tavolino



The Padiglione delle Feste (Party Pavilion) in Castrocaro Terme plunges us into the past, into the backdrops of holidays and leisure in the 1930s: its immense main hall, the enormous ballroom, the banquet room, the room of cards. All the spaces, entirely unchanged over time, embody grandeur.

Il Padiglione delle Feste di Castrocaro Terme è un tuffo nel passato, nelle atmosfere di vacanza e svago anni Trenta: la hall immensa, l'enorme sala da ballo, il salone dei banchetti, le sale delle carte, tutti gli spazi, completamente intatti, esprimono grandeur.





Shirley bench / panca

Clamp low table / tavolino



Norah chair / sedia

Clamp low table / tavolino



Galet low tables / tavolini



Vesper seating system / sistema di seduta
Kendama lamps / lampade

Galet low tables / tavolini



Castrocaro Terme

PLACES TO LIVE SINCE 1898



Otto pouf

Vesper seating system / sistema di seduta
Buds fragrance diffuser / diffusore di profumo



Galet low table / tavolino



Edward vanity

Montgomery small armchair / poltroncina







Aldia seating system / sistema di sedute

Koi baskets / ceste



It's a very photogenic, fascinating and inspiring place, which helps you get the right shot. The ceramic decorations are incredible: the colours, the iconography, and the abundance of materials and details fuse perfectly with the rationalist architecture of the building, which however, isn't the minimalism of Terragni.

It's a richer, slightly bohemian version where logic encounters joy and feeling.

È un luogo molto fotogenico, affascinante e stimolante, che aiuta a trovare l'inquadratura corretta.

Le decorazioni in ceramica sono meravigliose: i colori, le iconografie, la ricchezza dei materiali e dei dettagli si sposano perfettamente con l'architettura razionalista dell'edificio, che non è però quella minimalista di Terragni, è una versione più ricca, un po' bohémien, dove la ragione incontra la gioia e il sentimento.



Borealis screen / paravento

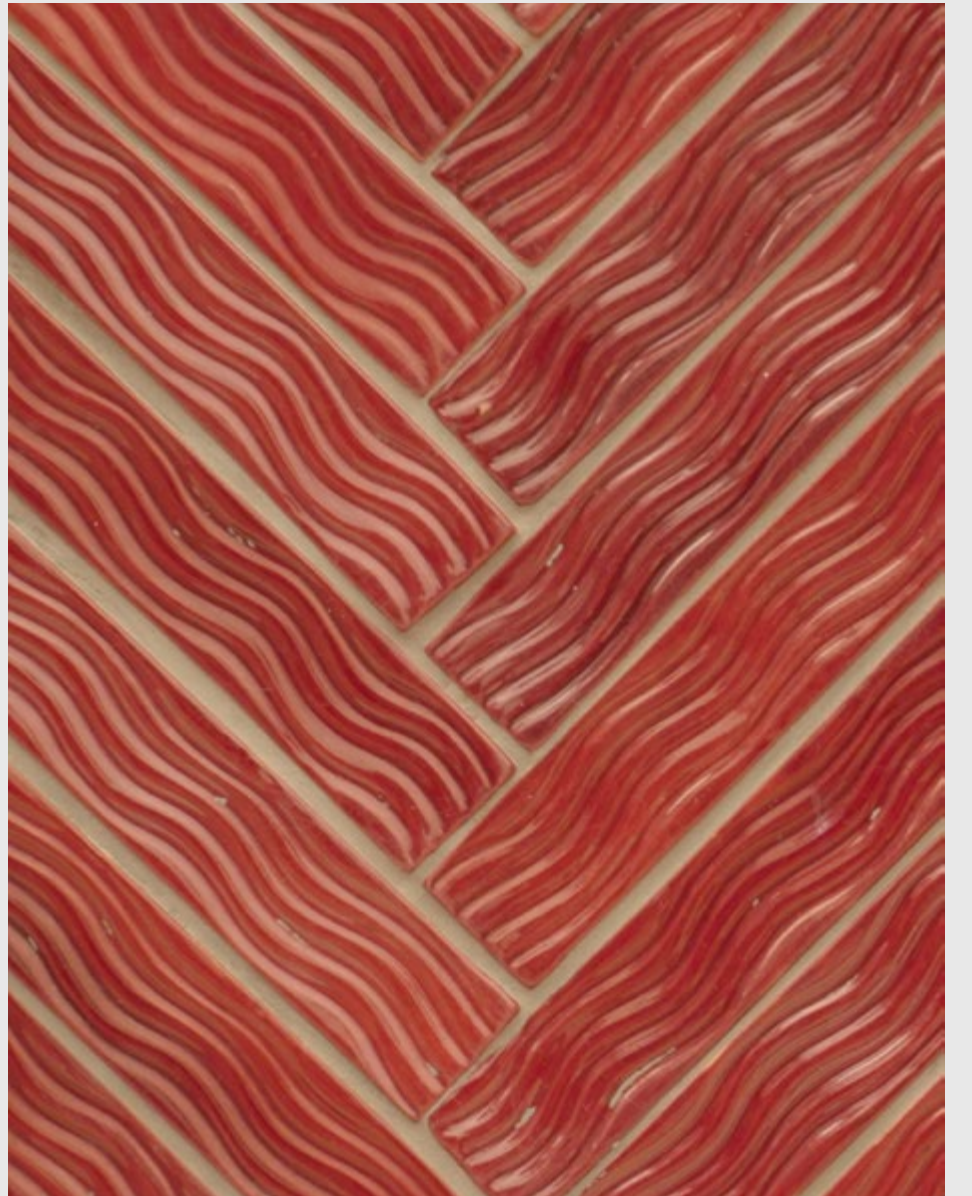

Aura armchairs / poltrone **Ray** low table / tavolino **Borealis** screen / paravento
Charlotte cabinet / contenitore **Crystal Stone** set of bar glasses, wine coolers and bottles /
 set di bicchieri bar, glacette e bottiglie **Liling** carpet / tappeto



Aura armchair / poltrona



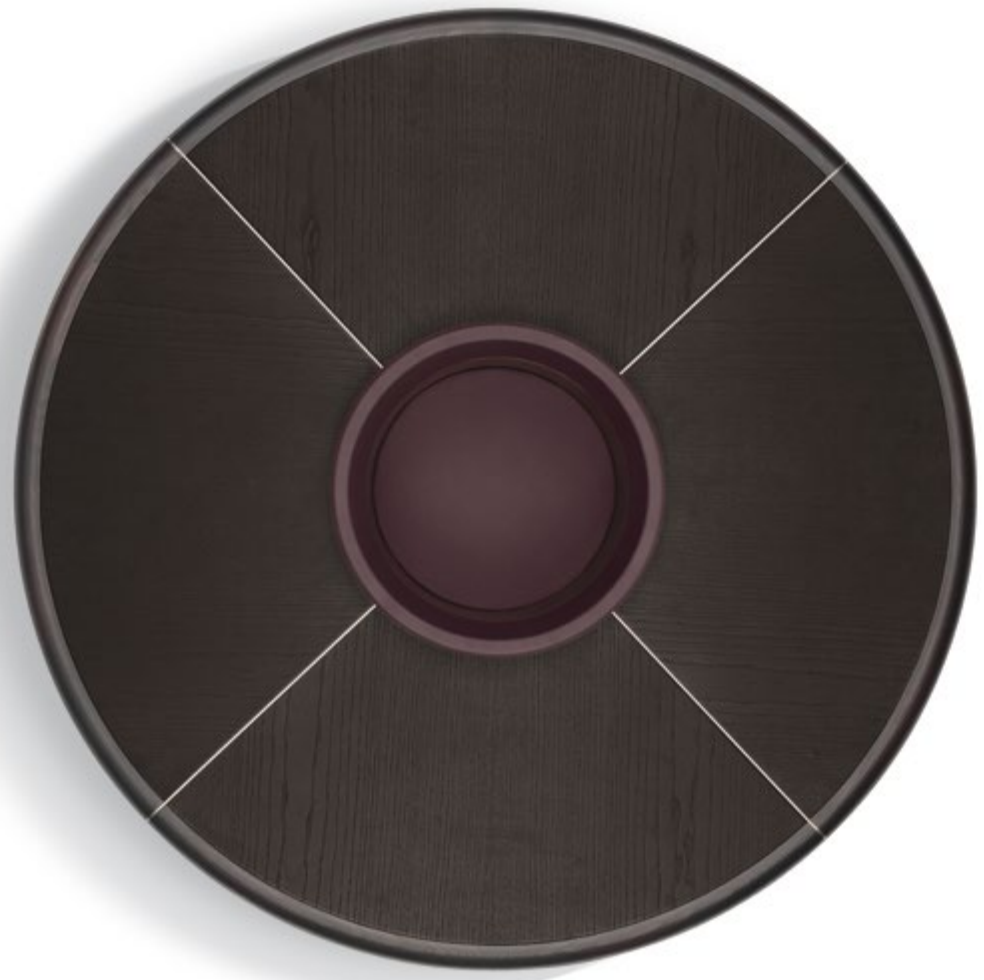

Aura armchair / poltrona
Liling carpet / tappeto

Ray low table / tavolino

Borealis screen / paravento



The beauty of decorative details, prized materials, unique spaces designed to exalt life's essential elements: beauty and culture as authentic sources of meaning and significance.

La bellezza dei dettagli decorativi, i materiali pregiati, le atmosfere uniche fatte di ambienti progettati per esaltare gli elementi essenziali della vita, la bellezza, la cultura come autentiche fonti di senso e significato.

Shibus cabinet / contenitore

Atena, Roman vases / vasi

Crystal Stone set of bar glasses, wine coolers and bottles / set di bicchieri bar, glacette e bottiglie



Aldia table / tavolo

Montgomery small armchairs / poltroncine

Shibusa cabinet / contenitore

Atena, Roman vases / vasi

Crystal Stone set of bar glasses, wine coolers and bottles / set di bicchieri bar, glacette e bottiglie

Tivoli, Villa d'Este Pond, Fujishima Takeji, University Art Museum, Tokyo University of the Arts, Japan



T. MARZENO

T. SAMBUCIA

Terme di Sole

Castrocaro

Castrocaro Terme

PLACES TO LIVE SINCE 1898



Flamingo gaming table / tavolo da gioco Annette chairs / sedie
Houdini cabinet / contenitore Host trolley / carrello
Crystal Stone set of bar glasses, wine coolers and bottles / set di bicchieri bar, glacette e bottiglie



Flamingo gaming table / tavolo da gioco Annette chair / sedia

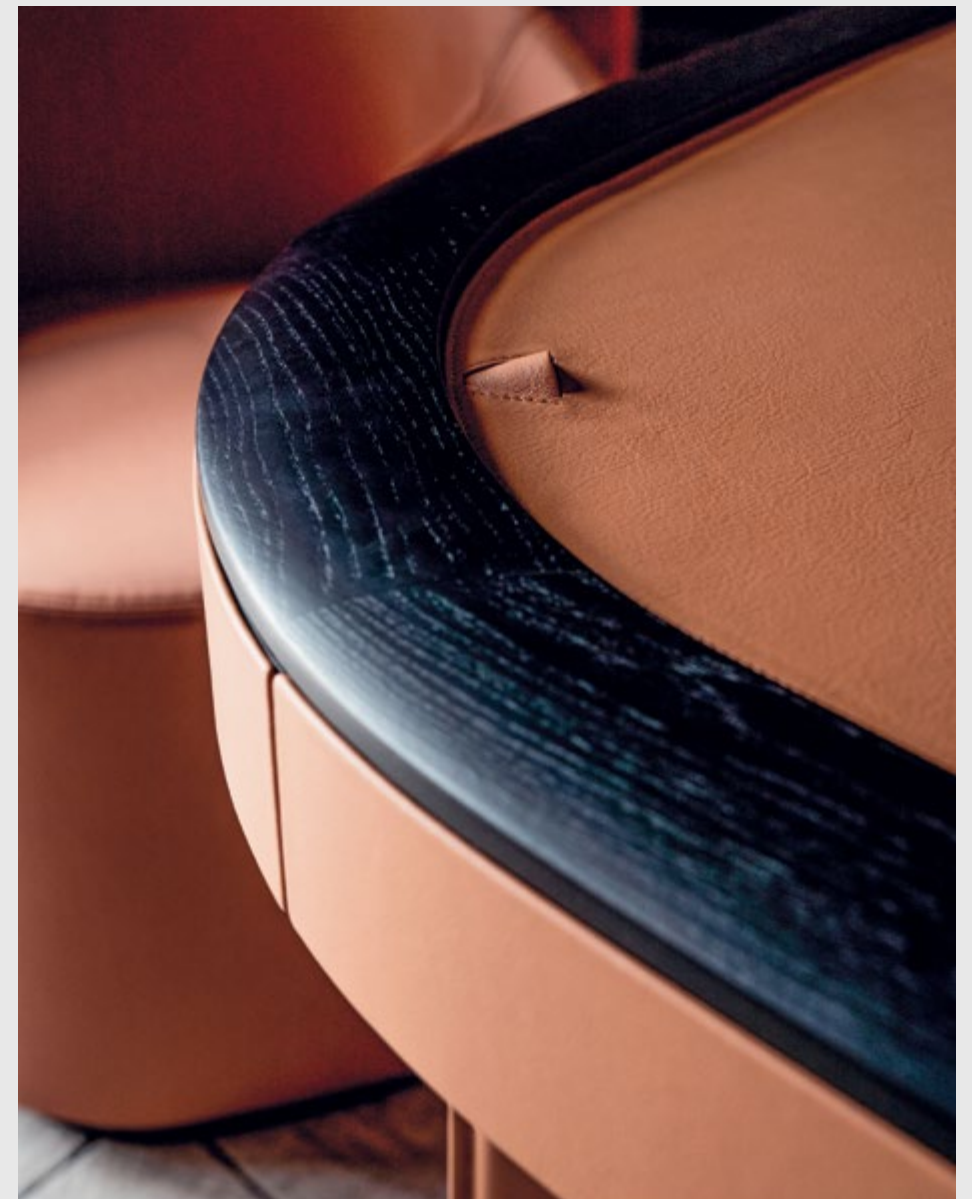



Annette chairs / sedie

Flamingo gaming table / tavolo da gioco

Annette chairs / sedie

Crystal Stone set of bar glasses, wine coolers and bottles / set di bicchieri bar, glaccette e bottiglie



Castrocaro Terme

PLACES TO LIVE SINCE 1898





Edward vanity

Montgomery small armchair / poltroncina



Vibe bed / letto
Edward vanity

Side Vibe bedside table / comodino
Montgomery small armchair / poltroncina

Trace wallpaper / carta da parati
Frequency carpet / tappeto



Ode stools / sgabelli





Montgomery armchair / poltroncina

Montgomery armchairs / poltroncine

Borealis screen / paravento



A house where the Renaissance meets contemporary art

Palazzo Beccaguti Cavriani

MANTOVA 2021

EN — The 16th century Palazzo Beccaguti Cavriani is a beautiful old building that has been enhanced by a renovation to restore its architectural elements and highlight its perfect geometries. There is history behind it, but there is also a desire to stay in step with the evolution of the way we do things, the way we think about housing, architecture and art. The building and its city, Mantua, reflect the combination of history and innovation, of love for the past but also of a continuous and constant desire to dig deeper and remain up-to-date. And to enjoy the best our era, our moment in time, has to offer.

IT — Il Palazzo cinquecentesco Beccaguti Cavriani, un edificio con una grande storia, esaltata dall'ultimo intervento che ha ripulito le architetture e ne ha messo in evidenza le geometrie perfette. C'è una storia alle spalle, ma c'è anche una volontà di seguire l'evoluzione del modo di fare, di immaginare l'abitazione, l'architettura e l'arte. Il palazzo e la sua città, Mantova, riflettono il connubio di storia e innovazione, di amore per il passato ma anche di una volontà continua e costante di fare ricerca e mantenersi aggiornati. Godere nel vivere il meglio della nostra era, del nostro momento.



Hug armchairs / poltrone

Clamp small tables / tavolini



An interplay of reflections, between outdoor and indoor.
The metaphysical arches of the courtyard connect the outdoor space with the living room.

Giochi di riflessi, tra esterni e interni. Le arcate metafisiche del cortile mettono in comunicazione lo spazio open air con l'ambiente living.

Adam bed / letto
Summa pouf

Corium night tables / comodini
Shed carpet / tappeto

Gallery Brun Fine Art, bronze sculpture / scultura in bronzo

Uyuni, Amiral mirrors / specchiere

Disegno Gallery, Maurizio Donzelli, art piece / opera d'arte

Shirley panca / bench

Kendama lamp / lampada





Janet armchairs / poltrone

Janet armchairs / poltrone

Clop rocking seat / seduta a dondolo

Domus system / sistema

Skyline low table / tavolino

Kendama lamp / lampada

Moonshadow carpet / tappeto

Gallery Brun Fine Art, Bruno Cassinari, sculpture / scultura

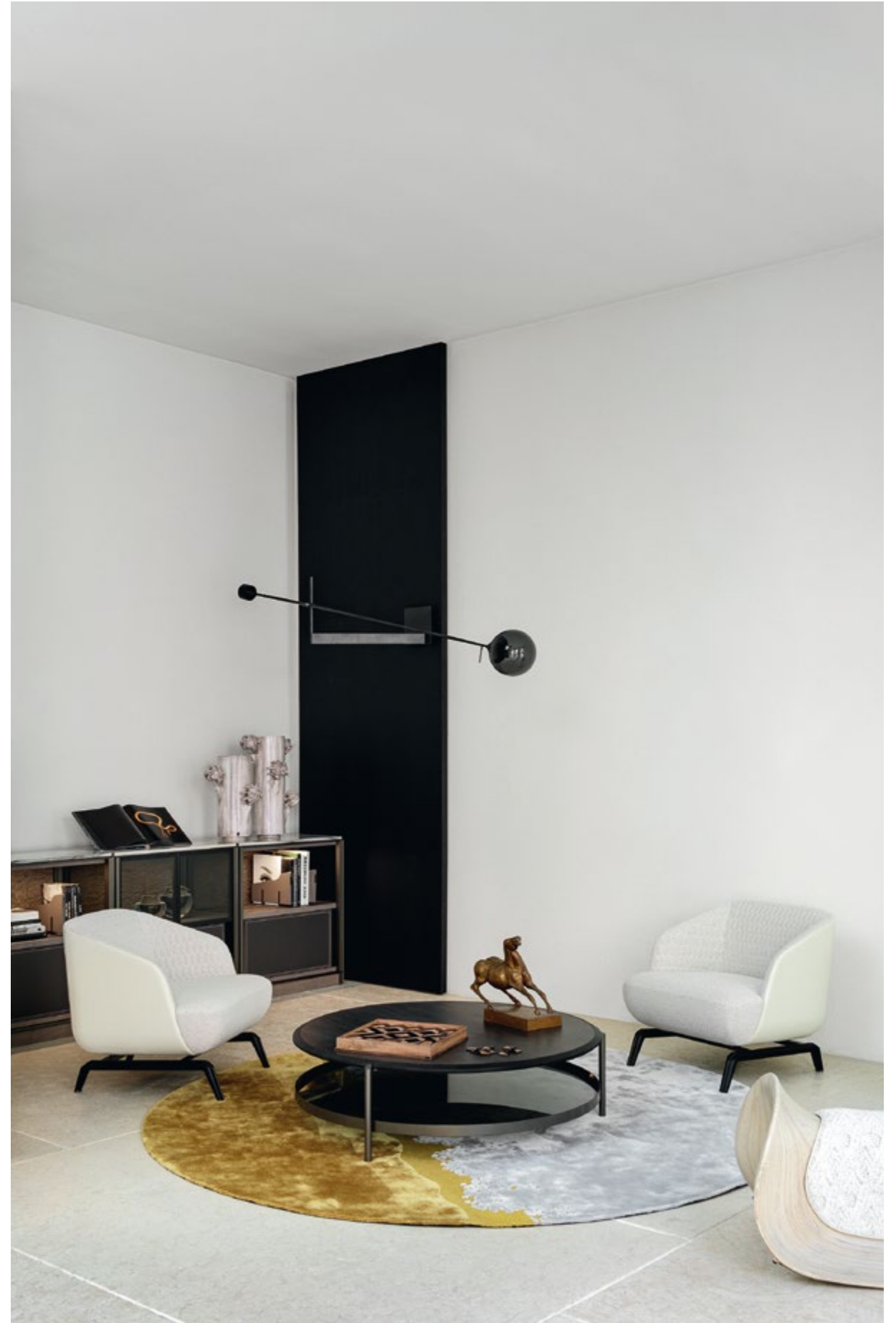



Shirley bench and mirror / panca e specchio
Frequence carpet / tappeto

Clamp low table / tavolino

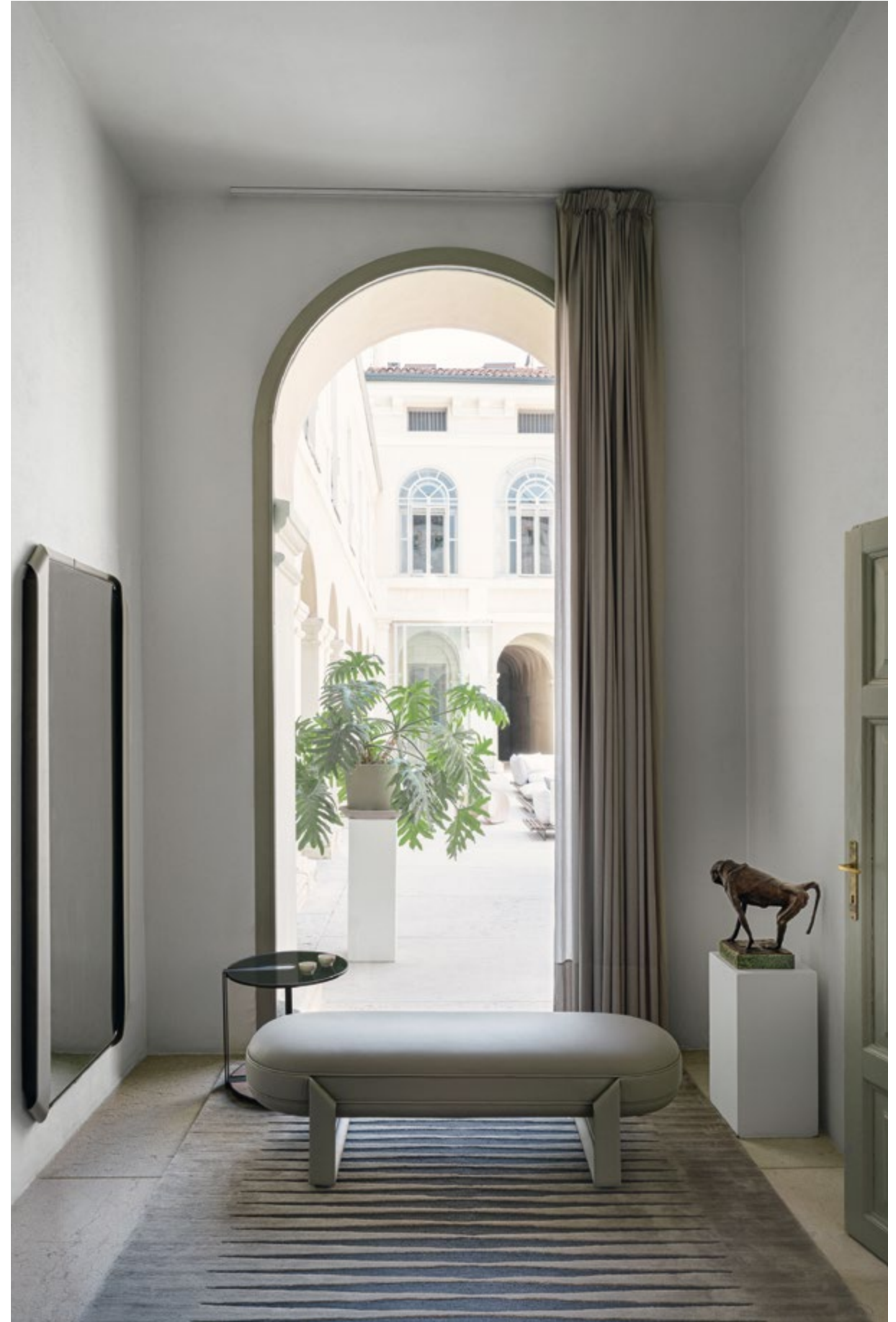

Skyline seating system / sistema di sedute Scaleno low tables / tavolini Host cabinet and trolley / mobile bar e carrello Domus system / sistema
Crystal Stone set of bar glasses, wine coolers and bottles / set di bicchieri bar, glaccette e bottiglie Harria vases / vasi Sataria carpet / tappeto
 Gallery Brun Fine Art, Marino Marini, bronze sculpture / scultura in bronzo



Scaleno low tables / tavolini
Salaria carpet / tappeto

Domus system / sistema

Harria vases / vasi



Purity and formal rigour make the house seem almost institutional, but in reality, it's a home where everything is usable for domestic life, and the coexistence of elements from the past and a contemporary attitude make it a living, familiar place.

Per purezza e rigore formale sembra una casa quasi istituzionale, ma in realtà è un'abitazione dove tutto è fruibile per una vita domestica, e la convivenza tra elementi del passato e attitudine al contemporaneo la rendono un luogo vivo e familiare.



Loop small armchairs / poltroncine

Break table / tavolo

Gea lamp / lampada

Gea trays / vassoi



Loop small armchairs / poltroncine

Break table / tavolo

Gea trays / vassoi



Palazzo Beccaguti Cavriani

PLACES TO LIVE SINCE 1898



Tie chairs / sedie

Houdini cabinet / contenitore

Mezzaluna Gallery, Ernesto Treccani, ceramic sculptures / sculture in ceramica



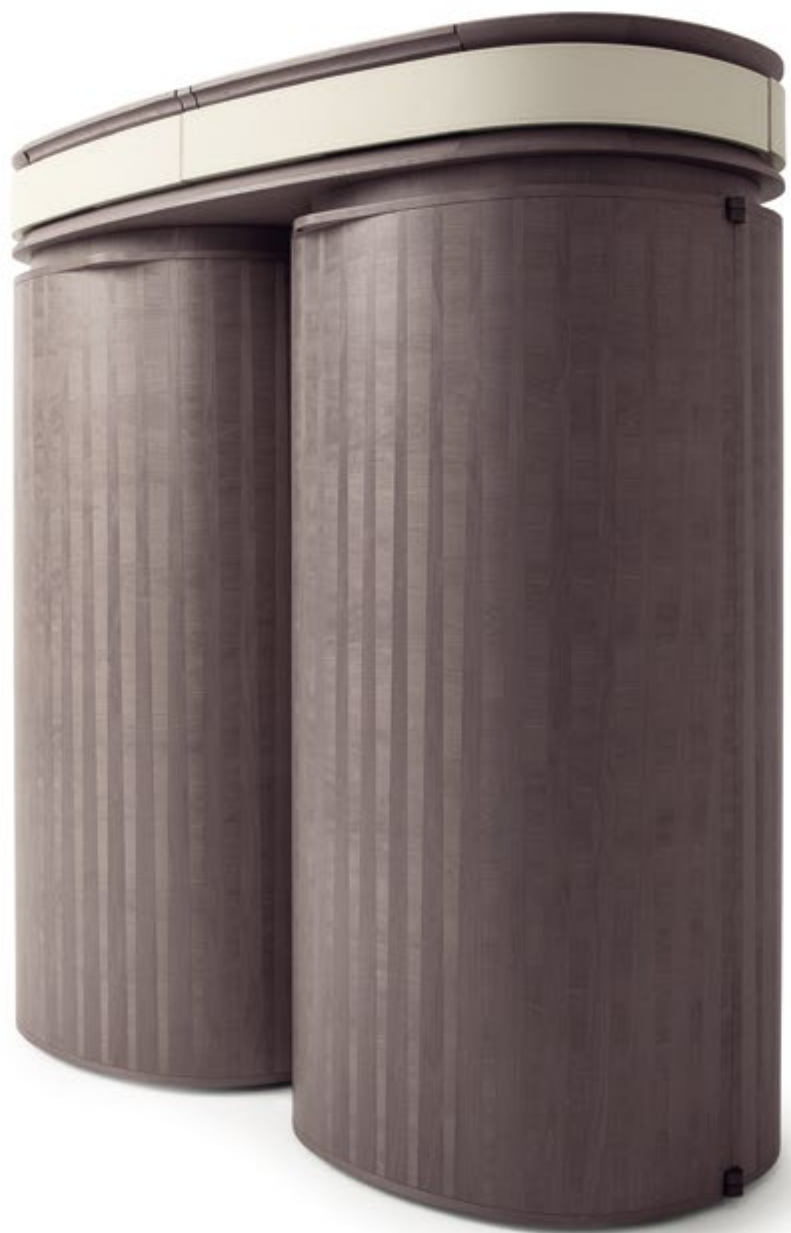

Houdini cabinet / contenitore



Houdini cabinet / contenitore



The complex architecture of the building offers many different spaces, different trajectories and ways of living.

La complessa architettura del palazzo offre molti spazi, eterogenei tra loro, diverse traiettorie di atmosfere e modi di abitare.

Palazzo Beccagutti Cavriani

PLACES TO LIVE SINCE 1898



Tamino armchairs / poltrone

Houdini cabinet / contenitore

Clamp low table / tavolino



PLACES TO LIVE SINCE 1898

Palazzo Beccaguti Cavriani

344

345



Apsara seating system and small tables / sistema di seduta e tavolini
Gea lamp and candle holders / lampada e porta candele

Loop small armchairs / poltroncine

Clop rocking seats / sedute a dondolo

Koi basket / cesta



Aldia table and small armchairs / tavolo e poltroncine

Gea trays / vassoi

Amazonia sculptures / sculture



Apsara seating system and small tables / sistema di seduta e tavolini
Gea candle holders / porta candele

Loop small armchairs / poltroncine

Clop rocking seat / seduta a dondolo

Koi basket / cesta





Amazonia sculpture / scultura



The garden, almost a hortus conclusus, a sort of small urban jungle that lives entirely off nature, has been furnished with outdoor pieces in warm, dynamic, vital textiles and colours, mirroring and interpreting the other outdoor environment: the courtyard.

Il giardino esterno, quasi un hortus conclusus - una sorta di piccola giungla urbana che vive totalmente di natura - è stato arredato con un outdoor dai tessuti e colori caldi, dinamici, vitali, che offre un'interpretazione speculare all'ambiente outdoor nel cortile.



Gea small armchairs / poltroncine



Gea small armchair / poltroncina

Aldia open-air collection Clop rocking seat / seduta a dondolo
Roberto Cambi, sculptures / sculture



Aldia open-air collection



Aldia open-air collection

Clop rocking seat / seduta a dondolo



Decoration is not merely an end in itself: many social contexts and bonds are formed around ornamental objects, capable of giving direct, immediate character to a space, warming it with a sort of intimate, private sentiment.

Il decor non è fine a se stesso, molte sono le situazioni conviviali, i legami, che accadono intorno agli oggetti ornamentali, capaci di caratterizzare gli ambienti in una maniera forte, immediata, e riscaldare l'atmosfera con una sorta di affettività intima, privata.

Move rocking chair / poltrona a dondolo

Brun Fine Art Gallery, cabinet in ebony wood / stipo in legno ebanizzato



Ago table / tavolo **Bicolette** chairs / sedie **Dia** cabinet / contenitore
Sliver lamp / lampada **Roman, Wave** vases / vasi **Liling** carpet / tappeto
Disegno Gallery, Italo Bressan, painting / dipinto

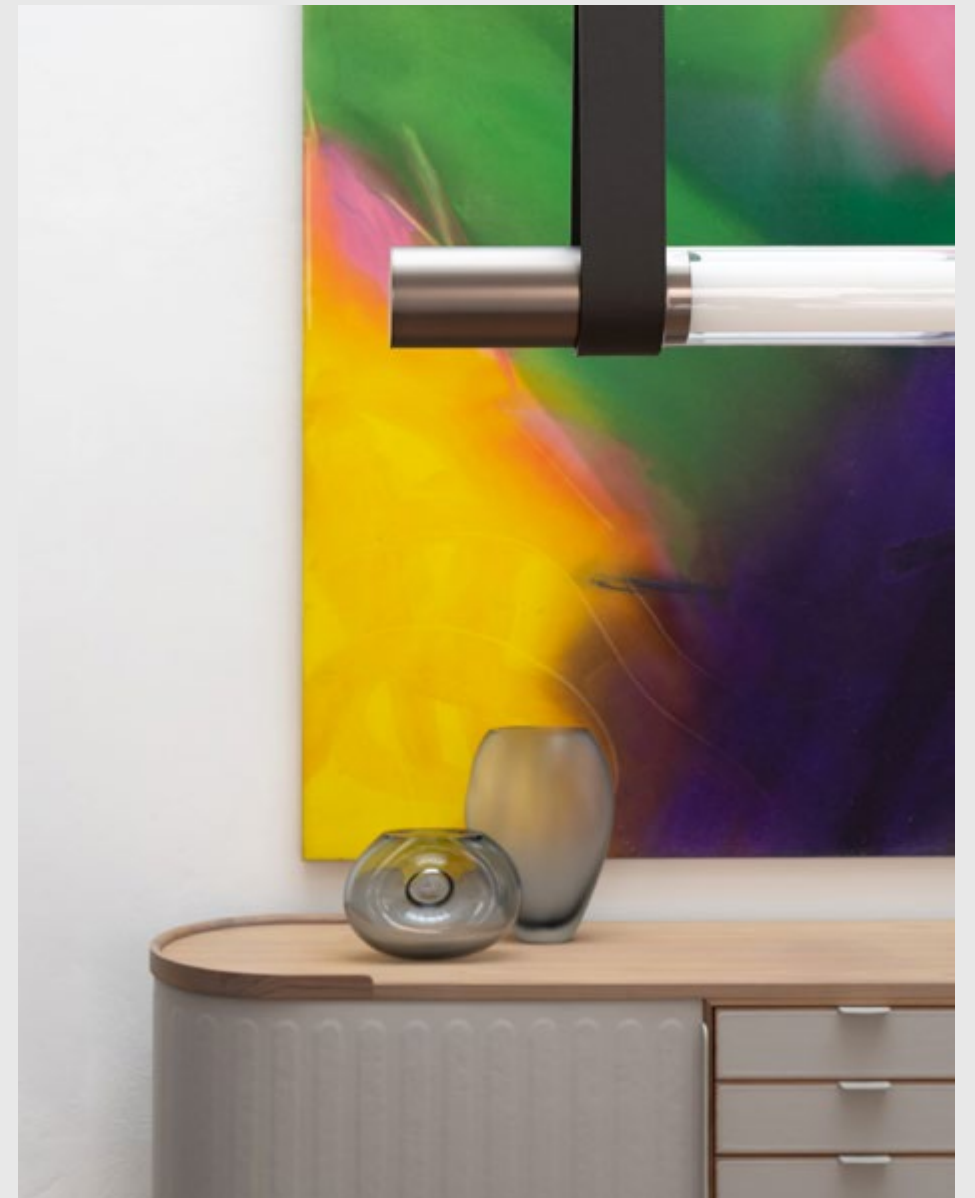



90° minuto football table / calcetto

Hineri vases / vasi

Moonshadow carpet / tappeto



Finiture / Finishes

June / Giugno 2025

PLACES TO LIVE SINCE 1898



Lorelei sofas / divani:
 Abba 5341, Pelle Plus 9323, piping flexible wood; Chamonix 5421, Pelle Plus 9323, Pelle Plus 9323 /
 Abba 5341, Pelle Plus 9323, piping legno flessibile; Chamonix 5421, Pelle Plus 9323, Pelle Plus 9323 /
Floria table / tavolo:
 Calacatta marble, Pelle Plus 9315 /
 Marmo Calacatta, Pelle Plus 9315
Otto poufs:
 Flash 5450, Pelle Plus 9317; Flash 544, Pelle Plus 9313
Aei cabinet / contenitore:
 Natural Canaletto walnut (fin.11) / Noce Canaletto naturale
Kukei sideboards / madie:
 Grey ash wood (fin. 2R), Pelle Satin 9185 /
 Frassino cenere (fin. 2R), Pelle Satin 9185
Neomeris carpet / tappeto:
 A005, D004



Lorelei sofas / divani:
 Abba 5341, Pelle Plus 9323, piping flexible wood; Chamonix 5421, Pelle Plus 9323, Pelle Plus 9323 /
 Abba 5341, Pelle Plus 9323, piping legno flessibile; Chamonix 5421, Pelle Plus 9323, Pelle Plus 9323 /
Floria table / tavolo:
 Calacatta marble, Pelle Plus 9315 /
 Marmo Calacatta, Pelle Plus 9315
Neomeris carpet / tappeto:
 A005, D004

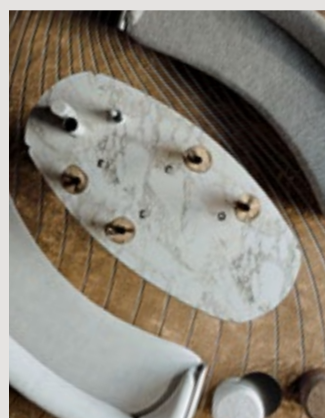

Lorelei sofas / divani:
 Abba 5341, Pelle Plus 9323, piping flexible wood; Chamonix 5421, Pelle Plus 9323, Pelle Plus 9323 /
 Abba 5341, Pelle Plus 9323, piping legno flessibile; Chamonix 5421, Pelle Plus 9323, Pelle Plus 9323 /
Floria table / tavolo:
 Calacatta marble, Pelle Plus 9315 /
 Marmo Calacatta, Pelle Plus 9315
Neomeris carpet / tappeto:
 A005, D004



Floria table / tavolo:
 Labradorite marble, Pelle Plus 9332 /
 Marmo Labradorite, Pelle Plus 9332
Plume chairs / sedie:
 Damaris 5320, piping Pelle Plus 9326, anthracite grey ash wood (fin. 93), caned /
 Damaris 5320, piping Pelle Plus 9326, frassino grigio antracite (fin. 93), paglia di Vienna
Charlotte cabinet / contenitore:
 Grey Canaletto walnut (fin.2W) /
 Noce Canaletto grigio (fin.2W)
Panopea carpets / tappeti:
 Military chic



Floria table / tavolo:
 Labradorite marble, Pelle Plus 9332 /
 Marmo Labradorite, Pelle Plus 9332
Plume chairs / sedie:
 Damaris 5320, piping Pelle Plus 9326, anthracite grey ash wood (fin. 93), caned /
 Damaris 5320, piping Pelle Plus 9326, frassino grigio antracite (fin. 93), paglia di Vienna
Panoepa carpets / tappeti:
 Military chic



Seidon sofas / divani:
 Flash 5443; Barren 5413
Attitude carpet / tappeti:
 D001, D088, D140



Seidon sofas / divani:
 Flash 5443, Barren 5413
Vesper pouf:
 Pelle Satin 9192
Teti pouf:
 Plutarco 1140, shaded lacquered base white-copper /
 Plutarco 1140, base laccata sfumata bianco-rame
Galet low table / tavolino:
 Leather 9110, Zebrino marble /
 Pelle 9110, marmo Zebrino
Kromis low table / tavolino:
 Ambra-Fumè-Trasparente acidato-Bronzo-Fumè
Scirocchio sideboard / madia:
 Anthracite grey ash wood (fin. 93) /
 Frassino grigio antracite (fin. 93)
Attitude carpets / tappeti:
 D001, D088, D140



Nereide sofa / divano:
 Valenzano 4135, Pelle Satin 9191, anthracite grey ash wood (fin. 93) /
 Valenzano 4135, Pelle Satin 9191, frassino grigio antracite (fin. 93)
Ligea low tables / tavolini:
 Anthracite grey ash wood (fin. 93); Calacatta marble, Pewter painted metal (fin.5L); Pelle Satin 9192 /
 Frassino grigio antracite (fin. 93); marmo Calacatta, metallo verniciato Pewter (fin.5L); Pelle Satin 9192
Ploto low table / tavolino:
 Pelle Plus 9185, Pewter painted metal (fin.5L), anthracite grey ash wood (fin. 93) /
 Pelle Plus 9185, metallo verniciato Pewter (fin.5L), frassino grigio antracite (fin. 93)
Neomeris carpet / tappeto:
 D001, D081, D041

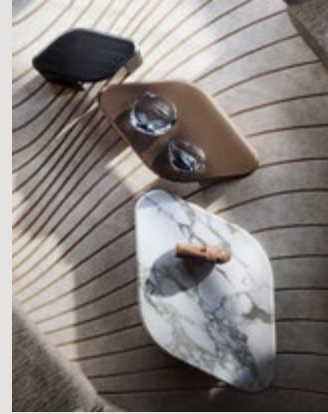

Ligea low tables / tavolini:
 Anthracite grey ash wood (fin. 93); Pelle Satin 9185;
 Calacatta marble, metallo verniciato Pewter (fin.5L) /
 Frassino grigio antracite (fin. 93), Pelle Satin 9185;
 Marmo Calacatta, metallo verniciato Pewter (fin.5L)
Neomeris carpet / tappeto:
 A119, A112, A003



Ploto low table / tavolino:
 Pelle Plus 9185, Pewter painted metal (fin.5L), anthracite grey ash wood (fin. 93) /
 Pelle Plus 9185, metallo verniciato Pewter (fin.5L), frassino grigio antracite (fin. 93)



Lorelei armchairs / poltrone:
 Duchessa 5239, lacquered glossy white /
 Duchessa 5239, laccata bianco lucido
Spark low table / tavolo:
 Zebrino marble, pewter-finish 5L painted aluminium and anthracite grey ash wood (fin. 93), Zebrino marble /
 Marmo Zebrino, alluminio verniciato finitura pewter 5L e frassino grigio antracite (fin. 93)
Hikari bar cabinet:
 Annealed, back-printed shaded and tempered glass, grey ash wood (fin. 2R), pewter painted metal (fin.5L) /
 Vetro ricotto, retro-stampato sfumato e temprato, grigio antracite (fin. 2R), metallo verniciato Pewter (fin.5L)
Light carpet / tappeto:
 A119, A003



Lorelei armchairs / poltrone:
 Duchessa 5239, lacquered glossy white /
 Duchessa 5239, laccato bianco lucido
Spark low table / tavolo:
 Zebrino marble, pewter-finish 5L painted aluminium, anthracite grey ash wood (fin. 93) /
 Marmo Zebrino, alluminio verniciato finitura pewter 5L, frassino grigio antracite (fin. 93)
Light carpet / tappeto:
 A119, A003



Tiber low table / tavolino:
 Pelle Plus 9313, grey ash wood (fin. 2R) /
 Pelle Plus 9313, frassino grigio cenere (fin. 2R)
Tiberina puof:
 Tinto 6522
Myabi, Reiwa walk in closet / cabina armadio:
 Antracite grey ash wood (fin. 93) /
 Frassino grigio antracite (fin. 93)



Frame bed / letto:
 Along 4123, saddle leather milky /
 Along 4123, cuoio latte
Sibilia low table / tavolino:
 Pewter painted metal (fin.5L), anthracite grey ash
 wood (fin. 93) /
 Metallo verniciato Pewter (fin.5L), frassino grigio
 antracite (fin. 93)



Frame bed / letto:
 Along 4123, saddle leather milky /
 Along 4123, cuoio latte
All Around armchair / poltrona:
 Anilina Nubuck 9255, Pelle Plus 9316 /
Chanterelle low table / tavolino:
 Anthracite grey ash wood (fin. 93), leather 9108 /
 Frassino grigio antracite, pelle 9108
Dual low table / tavolino:
 Ebony macassar /
 Ebano macassar
Sibilia low table / tavolino:
 Pewter painted metal (fin.5L), anthracite grey ash
 wood (fin. 93) /
 Metallo verniciato Pewter (fin.5L), frassino grigio
 antracite (fin. 93)
Beyond carpet / tappeto:
 E094, A003

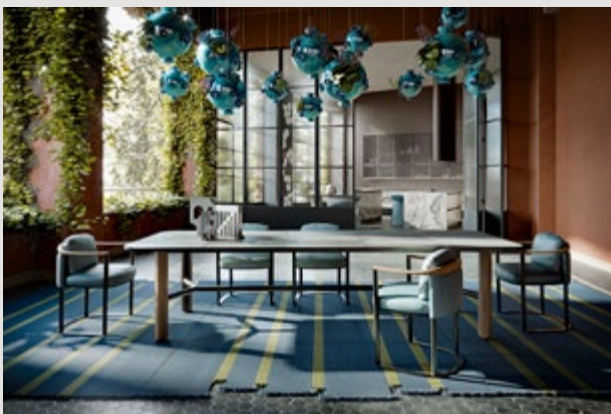

Moorea table / tavolo:
 Etna lava stone, AISI 316L stainless steel, Pewter painted
 (fin.5L), Teak wood /
 Pietra lavica dell'Etna, acciaio inox AISI 316L, verniciato
 Pewter (fin.5L), legno Teak
Moorea chairs / sedie:
 Monterey 1159, Pelle performa 9360, AISI 316L stainless steel,
 Pewter painted (fin.5L), Teak wood /
 Monterey 1159, Pelle performa 9360, acciaio inox AISI 316L,
 verniciato Pewter (fin.5L), legno Teak
Nisida carpets / tappeti:
 denim- olive green - turquoise



GK1, GK2 kitchen / cucina :
 Grey ash wood (fin. 2R), Arabescato Orobico marble /
 Frassino cenere (fin. 2R), marmo Arabescato Orobico
Skirt stools / sgabelli:
 Leather 9139 /
 Pelle 9139

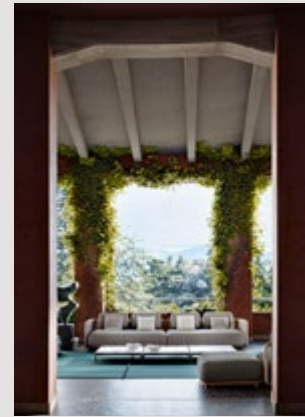

Moorea sofa / divano:
 Key west 1174, AISI 316L stainless steel, Pewter painted (fin.5L),
 Teak wood /
 Key west 1174, acciaio inox AISI 316L, verniciato Pewter (fin.5L),
 legno Teak
Nisida carpets / tappeti:
 denim- olive green - turquoise



Moorea sofas / divani:
 Key west 1174, Pool recycled 1175, Tulum 1180, AISI 316L stainless
 steel, Pewter painted (fin.5L), Teak wood /
 Key west 1174, Pool recycled 1175, Tulum 1180, acciaio inox AISI 316L,
 verniciato Pewter (fin.5L), legno Teak
Aldia low tables / tavolini:
 Palladiana marble, Pewter-finish 5L painted metal /
 Marmo Palladiana, metallo verniciato finitura Pewter 5L
Nisida carpets / tappeti:
 denim- olive green - turquoise



Moorea sunbeds / lettini:
 Magnetic 1143, AISI 316L stainless steel, Pewter painted (fin.5L),
 Teak wood /
 Magnetic 1143, Acciaio inox AISI 316L, verniciato Pewter (fin.5L),
 legno Teak
Kromis low table / tavolino:
 Blu-Fumè-Trasparente acidato-Bronzo-Fumè
Nisida carpets / tappeti:
 burgundy - terracotta - navy



Moorea sunbeds / lettini:
 Magnetic 1143, AISI 316L stainless steel, Pewter painted (fin.5L), Teak wood /
 Magnetic 1143, Acciaio inox AISI 316L, verniciato Pewter (fin.5L), legno Teak
Kromis low table / tavolino:
 Blu-Fumè-Trasparente acidato-Bronzo-Fumè
Nisida carpets / tappeti:
 burgundy - terracotta - navy



Karphi nap bed / letto:
 Salima 4090, Pelle Plus 9323
Clori armchair and pouf / poltrona e pouf:
 Alpaca 4084, saddle leather milky, natural Canaletto walnut (fin.11) with Pewter painted metal (fin.5L) inserts /
 Alpaca 4084, cuoio latte, noce Canaletto naturale (fin.11) con inserti in metallo verniciato Pewter (fin.5L)
Delphi night table / comodino:
 Pelle Plus 9323, fumé glass, dark Canaletto walnut (fin.2Z) /
 Pelle Plus 9323, vetro fumé, noce Canaletto scuro (fin.2Z)
Delphi chest / cassettoni:
 Pelle Plus 9322, dark Canaletto walnut (fin.2Z) /
 Pelle Plus 9322, noce Canaletto scuro (fin.2Z)
Delphi chest of drawers / cassetiera:
 Pelle Plus 9315 fumé glass, grey Canaletto walnut (fin.2W) /
 Pelle Plus 9315, vetro fumé, noce Canaletto grigio (fin.2W)
Liz-bench bench / panca:
 Anilina Nubuck 9259, grey Canaletto walnut (fin. 2W), Pelle Plus 9313 /
 Anilina Nubuck 9259, noce Canaletto grigio (fin. 2W), Pelle Plus 9313



Karphi nap bed / letto:
 Salima 4090, Pelle Plus 9323, dark Canaletto walnut (2Z) /
 Salima 4090, Pelle Plus 9323, noce Canaletto scuro (2Z)
Liz-valet valet / servomuto:
 Anilina Nubuck 9259, grey Canaletto walnut (fin. 2W), Pelle Plus 9313,
 Pewter painted metal (fin.5L) /
 Anilina Nubuck 9259, noce Canaletto grigio (fin. 2W), Pelle Plus 9313,
 metallo verniciato Pewter (fin.5L)
Light carpet / tappeto:
 D022, A114



Skyline seating system / sistema di seduta:
 Willis 5367
Chanterelle low tables / tavolini:
 Fumé glass, anthracite grey ash wood (fin. 93), Pelle Plus 9323 /
 Vetro fumé, frassino grigio antracite (fin. 93), Pelle Plus 9323
Borealis screens / paraventi:
 Pelle Plus 9313, Pewter painted metal (fin.5L) /
 Pelle Plus 9313, metallo verniciato Pewter (fin.5L)
Move armchair / poltrona:
 Duchessa 5233, anthracite grey ash wood (fin. 93) /
 Duchessa 5233, frassino grigio antracite (fin. 93)
Otto poufs:
 Tonga 5197, Claron 5346; Claron 5346, Infinity Cord 5185
Charlotte cabinet / contenitore:
 Grey Canaletto walnut (fin.2W), Calacatta marble /
 Noce grigio Canaletto (fin.2W), marmo Calacatta
Beyond carpet / tappeto:
 D082, B085



Solemydae sofas / divani:
 Kalipe 4101, Claron 5354
Chaterelle low table / tavolino:
 Fumé glass, grey ash wood (fin. 2R), Pelle Plus 9323 /
 Vetro fumé, frassino cenere (fin. 2R), Pelle Plus 9323
Ray low table / tavolino:
 Grey ash wood (fin. 2R), Pelle Plus 9313 /
 Frassino cenere (fin. 2R), Pelle Plus 9313
Lady armchair / poltrona:
 Pelle Plus 9313, Daydreamer 5213
Hikari bar cabinet:
 Grey ash wood (fin. 2R), leather 9111 /
 Frassino cenere (fin. 2R), pelle 9111
Moonshadow carpet / tappeto:
 A138, A017



Liz-console console / consolle:
 Pelle Plus 9313, grey Canaletto walnut (fin.2W), onyx /
 Pelle Plus 9313, noce Canaletto grigio (fin.2W), onice
Summa pouf:
 Glaze 4080, 4081, Pelle Plus 9320



Gordon table / tavolo:
 Natural maple (fin.98), saddle leather tobacco /
 Acero natural (fin.98), cuoio tabacco
Calathea executive bergères / poltrone direzionali:
 Pelle Plus 9313, Willis 5370

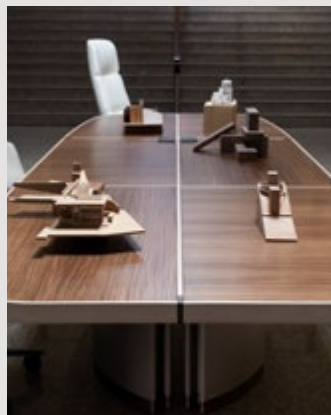

Gordon table / tavolo:
 Natural maple (fin.98), saddle leather tobacco /
 Acero natural (fin.98), cuoio tabacco
Calathea executive bergères / poltrona direzionali:
 Pelle Plus 9313



Mistral table / tavolo:
 Anthracite grey ash wood (fin.93), Levanto Red marble /
 Frassino grigio antracite (fin.93), Marmo Rosso Levanto
Plume chairs / sedie:
 Anthracite grey ash wood (fin.93), Duchessa 5238 and
 piping Pelle Plus 9317, Duchessa 5248 and piping Pelle Plus
 9313, Duchessa 5233 and piping Pelle Plus 9322, Duchessa 5
 239 and piping Pelle Plus 9137 /
 Frassino grigio antracite (fin.93), Duchessa 5238
 e piping Pelle Plus 9317, Duchessa 5248 e piping Pelle Plus
 9313, Duchessa 5233 e piping Pelle Plus 9322, Duchessa 5239
 e piping Pelle Plus 9137
Aei cabinets / contenitori:
 Natural Canaletto Walnut (fin.11), tempered glass /
 Noce Canaletto naturale (fin.11, vetro temperato



Soho seating system / sistema di seduta:
 Willbur 4119
Spark low table / tavolino:
 Anthracite grey ash wood (fin.93), Pewter painted metal (fin.5L) /
 Frassino grigio antracite (fin.93), metallo verniciato Pewter (fin.5L)
Summa pouf:
 Anilina Nubuck 9261, 9251, Claron 5340
Hikari sideboard / madia:
 Anthracite grey ash wood (fin.93), leather 9119 /
 Frassino grigio antracite (fin.93), pelle 9119



Tenet writing desk / scrivania:
 Saddle leather milky, dove grey maple (fin.2B) /
 Cuoio latte, acero grigio tortora (fin.2B)
Calathea executive bergère / poltrona direzionale:
 Pelle Plus 9313
Town containers / contenitori:
 Natural Canaletto walnut (fin.11, saddle leather milky /
 Noce Canaletto naturale (fin.11), cuoio latte
Frequence carpet / tappeto:
 D022, D049

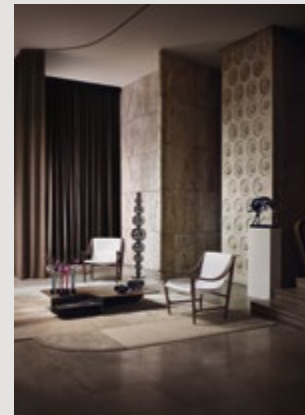

Swing armchairs / poltrone:
 Saddle leather milky, grey Canaletto walnut (fin.2W) /
 Cuoio latte, noce Canaletto grigio (fin.2W)
Ghiblim low table / tavolo:
 Grey Canaletto walnut (fin.2W), Grigio Orobico marble /
 Noce Canaletto grigio (fin.2W), marmo Grigio Orobico
Modular carpet / tappeto:
 A138



Vesper sofa, divano:
 Nelson 5358
Griffe low table / tavolino:
 Natural Canaletto walnut (fin.11), Palissandro marble /
 Noce Canaletto naturale (fin.11), marmo Palissandro
Progetti Fashion small armchair / poltroncina:
 Dark beech wood (fin.91), Katori sheepskin /
 Faggio scuro (fin.91), montone Katori
Mistral table / tavolo:
 Anthracite grey ash wood (fin.93) /
 Frassino grigio antracite (fin.93)
Liling carpet / tappeto:
 D022, E110



Mistral table / tavolo:
 Anthracite grey ash wood (fin. 93), Orobico marble /
 Frassino grigio antracite (fin. 93), marmo Orobico
Ibla chairs / sedie:
 Alcide 5201, Tonga 5194, anthracite grey ash wood (fin. 93) /
 Alcide 5201, Tonga 5194, frassino grigio antracite (fin. 93)
Amiral bookcase / libreria:
 Grey ash wood (fin. 2R), Pelle Plus 9327 /
 Frassino cenere (fin. 2R), Pelle Plus 9327

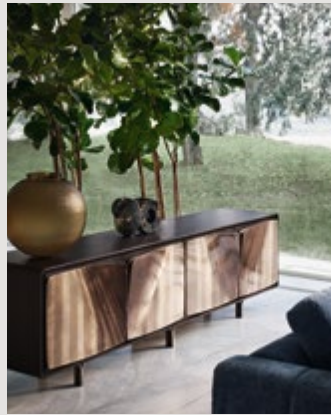

Scirocco sideboard / madia:
 Anthracite grey ash wood (fin. 93) /
 Frassino grigio antracite (fin. 93)



Karphi seating system / sistema di seduta:
 Claron 5351, Pelle Plus 9327
Chanterelle low table / tavolino:
 Fumè glass, grey ash wood (fin. 2R), Pelle Plus 9323 /
 Vetro fumè, frassino cenere (fin. 2R), Pelle Plus 9323
Scaleno low tables / tavolini:
 Anthracite grey ash wood (fin. 93), leather 9111,
 Calacatta marble /
 Frassino grigio antracite (fin. 93), pelle 9111,
 marmo Calacatta



Mistral table / tavolo:
 Anthracite grey ash wood (fin. 93), Orobico marble /
 Frassino grigio antracite (fin. 93), marmo Orobico
Lazy Susan tray / vassoio:
 Back-painted glass /
 Vetro retroverniciato
Amiral bookcase / libreria:
 Grey ash wood (fin. 2R), Pelle Plus 9327 /
 Frassino cenere (fin. 2R), Pelle Plus 9327



Karphi seating system / sistema di seduta:
 Damaris 5317
Eva bergère and pouf:
 Split 5281, milk shiny lacquered /
 Split 5281, laccatura lucida latte
Athene low tables / tavolini:
 Maple in dark finish (fin. 45), pau ferro /
 Acero in finitura scura (fin. 45), pau ferro
Scaleno low table / tavolino:
 Leather 9122, Calacatta marble, anthracite grey ash wood (fin. 93) /
 Pelle 9122, marmo Calacatta, frassino grigio antracite (fin. 93)
Frequence carpets / tappeti:
 D022, D049



G-Code table table / tavolo:
 Calacatta marble, grey Canaletto walnut (fin. 2W) /
 Marmo Calacatta, noce Canaletto grigio (fin. 2W)
Hero chairs / sedie:
 Mikado Cloud 4072, grey Canaletto walnut (fin. 2W) /
 Mikado Cloud 4072, noce Canaletto grigio (fin. 2W)



Hero chairs / sedie:
 Mikado Cloud 4072, grey Canaletto walnut (fin. 2W) /
 Mikado Cloud 4072, noce Canaletto grigio (fin. 2W)
G-Code Table table / tavolo:
 Calacatta marble, grey Canaletto walnut (fin. 2W) /
 Marmo Calacatta, noce Canaletto grigio (fin. 2W)



Tie XL armchair / poltrona:
 Alcide 5210, piping Pelle Plus 9323
Spark low tables / tavolini:
 Pelle Plus 9326, Pewter painted metal (fin.5L), anthracite grey ash wood
 (fin. 93), Calacatta marble, Pewter painted metal (fin.5L), anthracite
 grey ash wood (fin. 93) /
 Pelle Plus 9326, metallo verniciato Pewter (fin.5L), frassino grigio
 antracite (fin. 93), Marmo Calacatta, metallo verniciato Pewter (fin.5L),
 frassino grigio antracite (fin. 93)
Kukei sideboard / madia:
 Pelle Plus 9323, anthracite grey ash wood (fin. 93) /
 Pelle Plus 9323, frassino grigio antracite (fin. 93)



Tie XL armchair / poltrona:
Alcide 5210, piping Pelle Plus 9323
Spark low tables / tavolini:
Pelle Plus 9326, Pewter painted metal (fin.5L), anthracite grey ash wood (fin. 93), Calacatta marble, Pewter painted metal (fin.5L), anthracite grey ash wood (fin. 93) / Pelle Plus 9326, metallo verniciato Pewter (fin.5L), frassino grigio antracite (fin. 93). Marmo Calacatta, metallo verniciato Pewter (fin.5L), frassino grigio antracite (fin. 93)

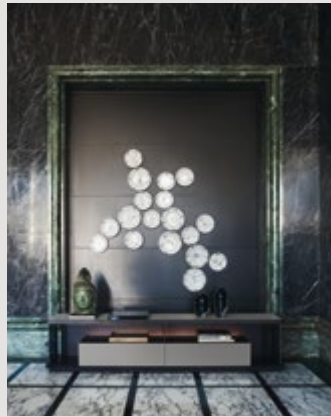

Kukei sideboard / madia:
Pelle Plus 9323, anthracite grey ash wood (fin. 93) / Pelle Plus 9323, frassino grigio antracite (fin. 93)



Altea bed / letto:
Mikado Cloud 4072, Pelle Performa 9353
Progetti armchair / poltrona:
Glaze 4081, dark beech wood (fin.54) / Glaze 4081, faggio scuro (fin.54)
Morfeo bed sidetable / comodino:
Leather 9108 / Pelle 9108
Domus cabinet / contenitore:
Calacatta marble, grey ash wood (fin. 2R) / Marmo Calacatta, frassino cenere (fin. 2R)
Whisper carpet / tappeto:
E055, E104



Progetti armchair / poltrona:
Glaze 4081, dark beech wood (fin.54) / Glaze 4081, faggio scuro (fin.54)
Griffe low table / tavolino:
Pelle Plus 9321, anthracite grey ash wood (fin. 93) / Pelle Plus 9321, frassino grigio antracite (fin. 93)
Domus cabinet / contenitore:
Calacatta marble, grey ash wood (fin. 2R) / Marmo Calacatta, frassino cenere (fin. 2R)



Mizar table / tavolo:
Calacatta marble, cast bronze / Marmo Calacatta, fusione di bronzo
Norah chairs / sedie:
Cruise Melange 5271, dark Canaletto walnut (fin. 2Z) / Cruise Melange 5271, noce Canaletto scuro (fin. 2Z)
Modular carpet / tappeto:
A138



Drive sofa / divano:
Claron 5344, piping Anilina Nubuck 9257
All Around armchairs / poltrone:
Pelle Plus 9321, Lounef 4075 /
Woody low tables / tavolini:
Calacatta viola marble, Pelle Plus 9322 Pelle Plus 9320
Marmo calacatta viola, Pelle Plus 9322. Pelle Plus 9320
Mia low tables / tavolini:
Calacatta viola marble, Pelle Plus 9322. Dark Canaletto walnut (fin. 2Z), Pelle Plus 9322 / Marmo Calacatta viola, Pelle Plus 9322. Noce Canaletto scuro (fin.2Z), Pelle Plus 9322
Borealis screen / paravento:
Anilina Nubuk 9262, Plus Plus 9322
Liling carpet / tappeto:
D022, E110



Woody low tables / tavolini:
Calacatta viola marble, Pelle Plus 9322. Pelle Plus 9320
Marmo calacatta viola, Pelle Plus 9322. Pelle Plus 9320
Mia low tables / tavolini:
Calacatta viola marble, Pelle Plus 9322. Dark Canaletto walnut (fin. 2Z), Pelle Plus 9322 / Marmo Calacatta viola, Pelle Plus 9322. Noce Canaletto scuro (fin.2Z), Pelle Plus 9322



Calathea armchair / poltroncina:
Split 5291, Pelle Plus 9319
Borealis screen / paravento:
Anilina Nubuk 9262, Pelle Plus 9322

**Gea sunbed / lettino:**

Alpina 1108, Plutarco 1110, aluminium powder painted in carob colour /
Alpina 1108, Plutarco 1110, alluminio verniciato a polvere color carruba

Gea rocking small armchair / poltroncina a dondolo:

Dehors 1024, stainless steel powder painted in carob colour /
Dehors 1024, acciaio inox verniciato a polvere color carruba

Gea low table / tavolino:

Stone oak (fin.3B), Etna lava stone, aluminium powder painted in carob colour /
Rovere fossile (fin.3B), pietra lavica dell'Etna, alluminio verniciato a polvere color carruba

Apsara low tables / tavolini:

Pewter painted metal (fin.5L), protected aluminium powder painted in carob colour /
Metallo verniciato Pewter (fin.5L), alluminio protetto verniciato polvere color carruba

**Skirt stools / sgabelli:**

Pelle Plus 9329, biscuit ash wood (fin. 2P) /
Pelle Plus 9329, frassino biscotto (fin. 2P)

**G-Code Desk desk / scrivania:**

Zebrino marble, grey Canaletto walnut (fin. 2W) /
Marmo Zebrino, noce Canaletto grigio (fin. 2W)

Calathea executive armchair / poltrona direzionale:

Pewter painted metal (fin.5L), Pelle Plus 9323 /
Metallo verniciato Pewter (fin.5L), Pelle Plus 9323

Urban sofa / divano:

Grey Canaletto walnut (fin. 2W), Anilina Sense 9248 /
Noce Canaletto grigio (fin. 2W), Anilina Sense 9248

Urban armchair / poltrona:

Grey Canaletto walnut (fin. 2W), Pelle Plus 9323, Cruise Chenille 5261 /
Noce Canaletto grigio (fin. 2W), Pelle Plus 9323, Cruise Chenille 5261

Round low table / tavolino:

Grey Canaletto walnut (fin. 2W) /
Noce Canaletto grigio (fin. 2W)

**Ripple small armchairs / poltroncine:**

Dante 6466 - 6461 -6459, grey Canaletto walnut (fin. 2W) /
Dante 6466 - 6461 -6459, noce Canaletto grigio (fin. 2W)

Griffe low table / tavolino:

Labradorite marble, grey Canaletto walnut (fin. 2W) /
Marmo labradorite, noce Canaletto grigio (fin. 2W)

**Opus armchairs / poltrone:**

Glaze 4077, natural Canaletto walnut (fin. 11) /
Glaze 4077, noce Canaletto naturale (fin. 11)

Spark low table / tavolino:

Anthracite grey mahogany sapelli (fin. 2G), sycamore maple, metallo verniciato Pewter (fin.5L), anthracite grey ash wood (fin. 93) /
Grigio antracite mogano sapelli (fin. 2G), acero sicomoro, metallo verniciato Pewter (fin.5L), frassino grigio antracite (fin. 93)

Summa pouf:

Lounet 4074, Pelle Plus 9332, Anilina Nubuck 9266

Cross Over carpet / tappeto:

D049, A114

**G-Code dresser dresser / cassetiera:**

Grey Canaletto walnut (fin. 2W) /
Noce Canaletto grigio (fin. 2W)

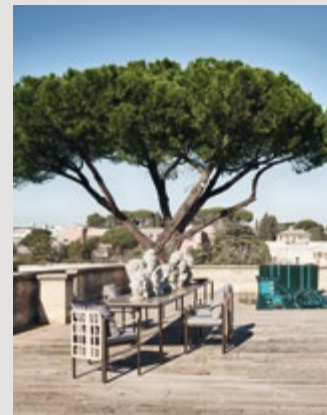
**Aldia table / tavolo:**

Palladiana Rialto, Pewter-finish 5L painted metal /
Palladiana Rialto, metallo verniciato finitura Pewter 5L

Aldia chairs / sedie:

Pewter painted metal (fin.5L), light grey birch wood (fin. 3G), EVA rubber, Plutarco 1118 /
Metallo verniciato Pewter (fin.5L), betulla grigio chiaro (fin. 3G), gomma EVA, Plutarco 1118

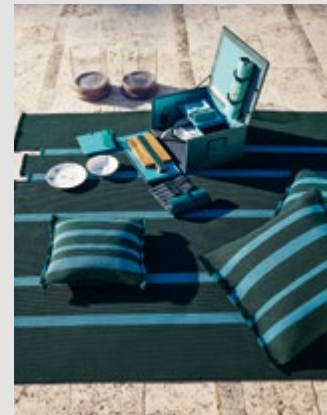
**Nisida carpet / tappeto:**

Turquoise, Forest, Olive green



G-Code Console console / consolle:
Calacatta marble, dark Canaletto walnut (fin. 2Z) / Calacatta marmo, noce Canaletto scuro (fin. 2Z)
Hero small armchair / poltroncina:
Split 5289, grey Canaletto walnut (2W) / Split 5289, noce Canaletto grigio (2W)
Fit low table / tavolino:
Calacatta marble, metal 5A, dark Canaletto walnut (fin. 2Z) / Calacatta marmo, metallo 5A, noce Canaletto scuro (fin. 2Z)
Breeze carpet / tappeto:
 E055



Kukei sideboard / madia:
Anthracite grey ash wood (fin. 93), grey ash wood (fin. 2R), Pelle Plus 9323 / Frassino grigio antracite (fin. 93), frassino cenere (fin. 2R), Pelle Plus 9323
Janet armchair / poltrona:
Anilina Nubuk 9258, Mikado 4070, dark Canaletto walnut (2Z) / Anilina Nubuk 9258, Mikado 4070, noce Canaletto scuro (2Z)
Shighera carpet / tappeto:
 A138, D049



Kukei sideboard / madia:
Anthracite grey ash wood (fin. 93), grey ash wood (fin. 2R), Pelle Plus 9323 / Frassino grigio antracite (fin. 93), frassino cenere (fin. 2R), Pelle Plus 9323
Shighera carpet / tappeto:
 A138, D049



Soho sofa / divano:
 Daydreamer 5220



Soho seating system / sistema di sedute:
 Daydreamer 5220, Terrazzo 4068, Anilina Nubuck 9266
Griffe low tables / tavolini:
Pelle 9332, Labradorite marble, grey Canaletto walnut (fin. 2W) / Pelle 9332, marmo Labradorite, noce Canaletto grigio (fin. 2W)
Kiri cabinet / contenitore:
Calacatta marble, dark Canaletto walnut (fin. 2Z) / Marmo Calacatta, noce Canaletto scuro (fin. 2Z)
Sataria carpet / tappeto:
 A138



Soho chaise lounge:
 Anilina Nubuck 9266
Griffe low tables / tavolini:
Labradorite marble, grey Canaletto walnut (fin. 2W) / Marmo Labradorite, noce Canaletto grigio (fin. 2W)
Sataria carpet / tappeto:
 A138



Shirley bench / panca:
 Biarritz 5116
Clamp low table / tavolino:
Pelle Plus 9323, vetro verniciato color Pewter / Pelle Plus 9323, Pewter-coloured painted glass



Norah chair / sedia:
 Alcide 5210 dark Canaletto Walnut (fin. 2Z) /
 Alcide 5210, noce Canaletto scuro (fin. 2Z)
Clamp low table / tavolino :
 Pelle Plus 9326, vetro verniciato color Pewter /
 Pelle Plus 9326, Pewter-coloured painted glass



Vesper seating system / sistema di seduta:
 Alcide 5210



Otto pouf:
 Leather 9108, Pebble 4034, Peltrox ® /
 Pelle 9108, Pebble 4034, Peltrox ®

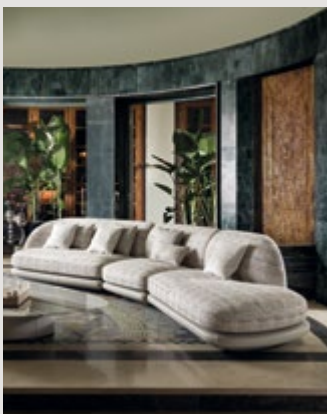

Vesper seating system / sistema di seduta:
 Pelle Plus 9323, Madama 525

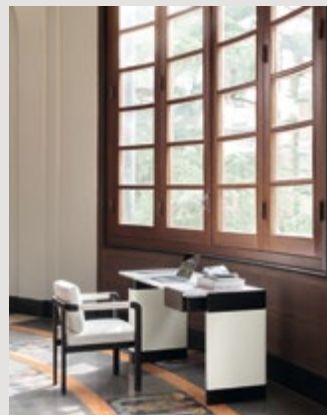

Edward vanity:
 Calacatta marble, leather 9108, anthracite ash wood (fin. 93) /
 Marmo Calacatta, pelle 9108, frassino grigio antracite (fin. 93)
Montgomery chair / sedia:
 Flash 5441, leather 9108, anthracite ash wood (fin. 93) /
 Flash 5441, pelle 9108, frassino grigio antracite (fin. 93)



Aldia seating system / sistema di sedute:
 Cima 1095., light grey birch wood (fin.3G), Pewter-finish 5L painted metal /
 Cima 1095, betulla grigio chiaro (fin.3G) metallo verniciato finitura Pewter 5L



Aura armchairs / poltrone:
 Anilina Nubuck 9262, Infinity Cord (5178), dark Canaletto walnut (fin.2Z) /
 Anilina Nubuck 9262, Infinity Cord (5178), noce Canaletto scuro (fin.2Z)
Ray low table / tavolino:
 Pelle Plus 9321, anthracite grey ash wood (fin. 93) /
 Pelle Plus 9321, frassino grigio antracite (fin. 93)
Borealis screen / paravento:
 Anilina Nubuck 9262, Pelle Plus 9322, Pewter painted metal (fin.5L) /
 Anilina Nubuck 9262, Pelle Plus 9322, metallo verniciato Pewter (fin.5L)
Charlotte cabinet / contenitore:
 Pelle Plus 9321, dark Canaletto walnut (fin.2Z) /
 Pelle Plus 9321, noce Canaletto scuro (fin.2Z)
Liling carpet / tappeto:
 D022, D049

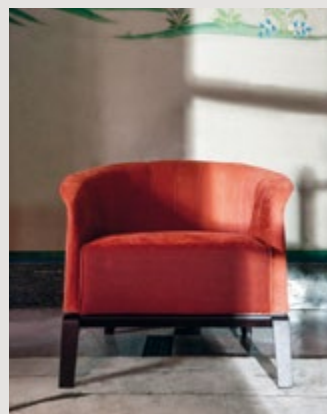

Aura armchair / poltrona:
 Anilina Nubuck 9262, Infinity Cord 5178, dark Canaletto walnut (fin.2Z) /
 Anilina Nubuck 9262, Infinity Cord 5178, noce Canaletto scuro (fin.2Z)



Aura armchairs / poltrone:
Anilina Nubuck 9262, Infinity Cord (5178), dark Canaletto walnut (fin.22) /
Anilina Nubuck 9262, Infinity Cord (5178), noce Canaletto scuro (fin.22)
Ray low table / tavolino:
Pelle Plus 9321, anthracite grey ash wood (fin. 93) /
Pelle Plus 9321, frassino grigio antracite (fin. 93)
Borealis screen / paravento:
Anilina Nubuck 9262, Pelle Plus 9322, Pewter painted metal (fin.5L) /
Anilina Nubuck 9262, Pelle Plus 9322, metallo verniciato Pewter (fin.5L)

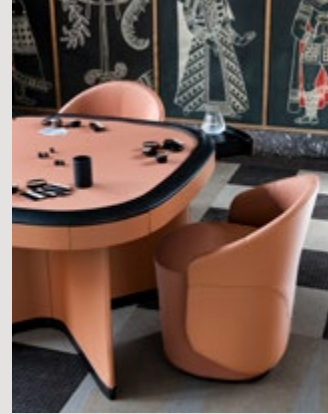

Flamingo gaming table / tavolo da gioco:
Harvard Spice, Pelle Plus 9317, anthracite grey ash wood (fin. 93) /
Harvard Spice, Pelle Plus 9317, frassino grigio antracite (fin. 93)
Annette chairs / sedie:
Harvard Spice, Pelle Plus 9317, anthracite grey ash wood (fin. 93) /
Harvard Spice, Pelle Plus 9317, frassino grigio antracite (fin. 93)



Shibusa cabinet / madia:
Ash grey ash wood (fin. 2R), grey glass /
Frassino cenere (fin. 2R), vetro grigio



Edward vanity:
Calacatta marble, leather 9108, anthracite grey ash wood (fin. 93) /
Marmo Calacatta, pelle 9108, frassino grigio antracite (fin. 93)
Montgomery chair / sedia:
Flash 5441, leather 9108, anthracite ash wood (fin. 93) /
Flash 5441, pelle 9108, frassino grigio antracite (fin. 93)



Shibusa cabinet / madia:
Ash grey ash wood (fin. 2R), grey glass /
Frassino cenere (fin. 2R), vetro grigio
Aldia table / tavolo:
Pewter-finish 5L, painted metal /
Metallo verniciato finitura Pewter 5L
Montgomery small armchairs / poltroncine:
Pelle Plus 9108, Matisse 4060, grey ash wood (fin. 2R) /
Pelle Plus 9108, Matisse 4060, frassino cenere (fin. 2R)



Vibe bed / letto:
Duchessa 5237
Side Vibe bedside table / comodino:
Calacatta marble, Pelle Plus 9313 /
Marmo Calacatta, Pelle Plus 9313
Edward vanity:
Calacatta marble, leather 9108, anthracite grey ash wood (fin. 93) /
Marmo Calacatta, pelle 9108, frassino grigio antracite (fin. 93)
Montgomery chair / sedia:
Flash 5441, leather 9108, anthracite ash wood (fin. 93) /
Flash 5441, pelle 9108, frassino grigio antracite (fin. 93)
Trace wallpaper / carta da parati:
Fluorite



Flamingo gaming table / tavolo da gioco:
Harvard Spice, Pelle Plus 9317, anthracite grey ash wood (fin. 93) /
Harvard Spice, Pelle Plus 9317, frassino grigio antracite (fin. 93)
Annette chairs / sedie:
Harvard Spice, Pelle Plus 9317, anthracite grey ash wood (fin. 93) /
Harvard Spice, Pelle Plus 9317, frassino grigio antracite (fin. 93)
Houdini cabinet / contenitore:
Leather 9110, natural Canaletto walnut (fin.11) /
Pelle 9110, noce Canaletto naturale (fin.11)
Host trolley / carrello:
Leather 9110, natural Canaletto walnut (fin.11) /
Pelle 9110, noce Canaletto naturale (fin.11)

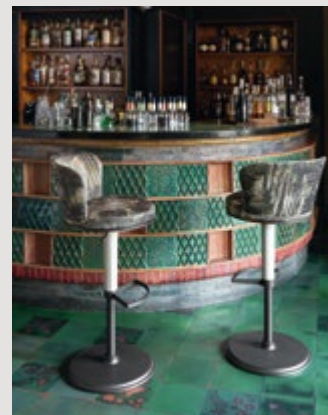

Ode stools / sgabelli:
Leather 9102, Tonga 5197, bronze colour painted metal (fin.47) /
Pelle 9102, Tonga 5197, metallo verniciato color bronzo (fin.47), /

**Montegomy armchairs / poltrone:**

Special fabric, leather 9149, anthracite grey ash wood (fin. 93) /

Tessuto speciale, pelle 9149, frassino grigio antracite (fin. 93)

Borealis screen / paravento:

Anilina Nubuck 9265, Pelle Plus 9313, Pewter painted metal (fin.5L) /

Anilina Nubuck 9265, Pelle Plus 9313, metallo verniciato Pewter (fin.5L)

**Hug armchairs / poltrone:**

Special fabric, dark Canaletto walnut (fin. 2Z) /

Tessuto speciale, noce Canaletto scuro (fin. 2Z)

Clamp small tables / tavolini:

Pewter painted glasses, dark Canaletto walnut (fin. 2Z) /

Pewter painted glasses, natural noce Canaletto (fin.11) / Vetro verniciato color Pewter, noce Canaletto scuro (fin.2Z) / Vetro verniciato color Pewter, noce Canaletto naturale (fin.11)

**Adam bed / letto:**

Alcide 5201, Pelle Plus 9323 /

Corium night tables / comodini:

Saddle leather milky, grey Canaletto walnut (fin. 2W) /

Cuoio latte, noce Canaletto grigio (fin. 2W)

Shirley bench / panca:

Loff 6364

Otto pouf:

Pebble 4034, Anilina Nubuck 9266

Uyuni mirror / specchiera:

Anthracite grey ash wood (fin. 93) /

Frassino grigio antracite (fin. 93)

Amiral mirror / specchiera:

Leather 9108, anthracite grey ash wood (fin. 93) /

Pelle 9108, frassino grigio antracite (fin. 93)

Shed carpet / tappeto:

D022, D082, A015

**Janet armchairs / poltrone:**

Pebble 4034, leather 9108, dark Canaletto walnut (2Z) /

Pebble 4034, pelle 9108, noce Canaletto scuro (2Z)

Domus system / sistema:

Zebrino marble, leather 9111, anthracite grey ash wood (fin. 93) /

Marmo Zebrino, pelle 9111, frassino grigio antracite (fin. 93)

Skyline low table / tavolino:

Anthracite grey ash wood (fin. 93), carbon Sapele pommele mahogany (2G), Pewter painted metal (fin.5L) /

Frassino grigio antracite (fin. 93), mogano Sapelli pommellè carbone (2G), metallo verniciato Pewter (fin.5L)

Moonshadow carpet / tappeto:

D022, C024

**Shiley bench / panca:**

Pelle Plus 9305

Shiley mirror / specchio:

Pelle Plus 9305

Clamp low table / tavolino:

Pewter painted glasses, natural noce Canaletto (fin.11) /

Vetro verniciato color Pewter, noce Canaletto naturale (fin.11)

Frequence carpet / tappeto:

D022, D049



Skyline seating system / sistema di sedute:
 Leather 9111, Duchessa 5256, Anilina Nubuk 9266 /
 Pelle 9111, Duchessa 5256, Anilina Nubuk 9266
Scaleno low tables / tavolini:
 Anthracite grey ash wood (fin. 93), Pelle Plus 9301,
 Calacatta marble /
 Frassino grigio antracite (fin. 93), Pelle Plus 9301,
 marmo Calacatta
Host cabinet and trolley / mobile bar e carrello:
 Grey Canaletto walnut (fin. 2W), leather 9108, Calacatta
 marble /
 Noce Canaletto grigio (fin. 2W), pelle 9108, marmo
 Calacatta
Sataria carpet / tappeto:
 A138



Ensō table / tavolo:
 Grey Sapele pommele mahogany (fin. 2F), leather 9108 /
 Mogano Sapelli pommellè grigio, (fin. 2F), pelle 9108



Domus system / sistema:
 Anthracite grey ash wood (fin. 93), grey Sapele pommele
 mahogany (fin. 2F), Pelle Plus 9305 /
 Frassino grigio antracite (fin. 93), mogano Sapelli pommellè
 cenere (fin. 2F), Pelle Plus 9305
Scaleno low tables / tavolini:
 Anthracite grey ash wood (fin. 93), Pelle Plus 9301, Calacatta
 marble /
 Frassino grigio antracite (fin. 93), Pelle Plus 9301, marmo
 Calacatta
Sataria carpet / tappeto:
 A138



Tie chairs / sedie:
 Daydreamer 5213, Anilina Nubuck 9255
Enso table / tavolo:
 Grey Sapele pommele mahogany, grey (fin. 2F), leather 9108 /
 Mogano Sapelli pommellè grigio, (fin. 2F), pelle 9108



Break table / tavolo:
 Etna lava stone, ash wood in sand finish (fin.3F) /
 Pietra lavica dell'Etna, frassino in finitura sabbia (fin.3F)
Loop small armchairs / poltroncine:
 Ash wood in sand finish (fin.3F), EVA rubber in blue bally
 finish, Filicudi 1077 /
 Frassino in finitura sabbia (fin.3F), gomma EVA in finitura
 blu, Filicudi 1077



Houdini cabinet / contenitore:
 Pelle Plus 9313, dove grey maple (fin. 2B) /
 Pelle Plus 9313, acero grigio tortora (fin. 2B)



Break table / tavolo:
 Etna lava stone, ash wood in sand finish (fin.3F) /
 Pietra lavica dell'Etna, frassino in finitura sabbia (fin.3F)
Loop small armchairs / poltroncine:
 Ash wood in sand finish (fin.3F), EVA rubber in blue bally
 finish, Filicudi 1077 /
 Frassino in finitura sabbia (fin.3F), gomma EVA in finitura
 blu, Filicudi 1077



Houdini cabinet / contenitore:
 Pelle Plus 9313, natural Canaletto walnut (fin. 2W) /
 Pelle Plus 9313, noce Canaletto natural (fin. 2W)



Houdini cabinet / contenitore:
*Pelle Plus 9313, natural Canaletto walnut (2W) /
 Pelle Plus 9313, noce Canaletto natural (2W)*
Tamino armchairs / poltrone:
Anilina Nubuck 9257, Infinity Cord 5180



**Apsara seating system and small tables /
 sistema di seduta e tavolini:**
*Filicudi 1076, protected aluminium, powder painted
 in carob colour and afrormosia wooden slats (fin.3B) /
 Filicudi 1076, alluminio protetto, verniciato a polvere color
 carruba e doghe in legno di afrormosia (fin.3B)*
Loop small armchairs / poltroncine
*Alpina 1127, ash wood in sand finish (fin.3F), EVA rubber
 in white finish /
 Alpina 1127, frassino in finitura sabbia (fin.3F), gomma
 EVA in finitura sabbia*
Clop rocking seats / sedute a dondolo:
Pied De Poule 1126, Alpina 1127



Aldia table / tavolo:
*Palladiana Fenice, Pewter-finish 5L painted metal /
 Palladiana Fenice, metallo verniciato finitura Pewter 5L*
Aldia smal armchairs / poltroncine:
*Plutarco 1118, light grey birch wood (fin. 3G), EVA rubber,
 Petwer painted metal (fin.5L) /
 Plutarco 1118, betulla grigio chiaro (fin. 3G), gomma EVA,
 Metallo verniciato Petwer (fin.5L)*



Gea chairs / sedie:
*Check 1137, stainless steel powder painted in carob
 colour, birch plywood (fin.3A) /
 Check 1137, acciaio inox verniciato a polvere color
 carruba, multistrato di betulla (fin.3A)*



Aldia seating system:
*Plutarco 1140, Erfoud 1123, Cima 1125, light grey birch wood (fin.3G) /
 Plutarco 1140, Erfoud 1123, Cima 1125, betulla grigio chiaro (fin.3G)*
Clop rocking seat / seduta a dondolo:
*Pied De Poule 1126, betulla con finitura naturale (3A) /
 Pied De Poule 1126, betulla con finitura naturale (3A) /*

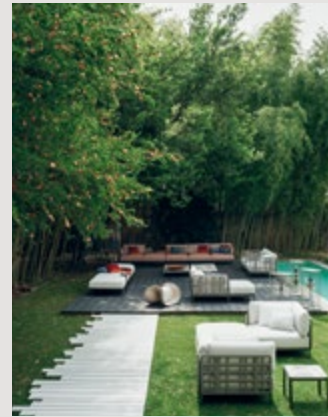

Aldia seating system:
*Plutarco 1140, Erfoud 1123, Cima 1125, light grey birch wood (fin.3G) /
 Plutarco 1140, Erfoud 1123, Cima 1125, betulla grigio chiaro (fin.3G)*
Clop rocking seat / seduta a dondolo:
*Pied De Poule 1126, betulla con finitura naturale (fin. 3A) /
 Pied De Poule 1126, betulla con finitura naturale (fin. 3A) /*



Move armchair / poltrona:
*Special gabric, anthracite ash wood (fin. 93) /
 Tessuto speciale, frassino grigio antracite (fin. 93)*



Ago table / tavolo:
*Grey Canaletto walnut (2W), Pewter painted metal (fin.5L) /
 Noce Canaletto grigio (2W), metallo verniciato Pewter (fin.5L)*
Bicolette chairs / sedie:
Biarritz 516, Pelle Plus 9332
Dia cabinet / contenitore:
*Grey Canaletto walnut (2W), Pelle Plus 9305 /
 Noce Canaletto grigio (2W), Pelle Plus 9305*
Liling carpet / tappeto:
D022, D049



Kiri cabinet / contenitore:
Calacatta marble, grey Canaletto walnut (fin.2W) /
Marmo Calacata, noce Canaletto grigio (fin.2W)
90° minuto football table / calcetto:
Saddle leather milk /
Cuoio latte
Moonshadow carpet / tappeto:
D022, C024

Index / Indice

June / Giugno 2025

PLACES TO LIVE SINCE 1898

90° minuto	367	GK 2	76
Adam	318	Griffe	142, 195, 226, 258, 262,
Aci	12, 120	Gordon	114, 116
Ago	364	Harria	168, 216, 222, 324, 326
Aldia	79, 80, 239, 281, 292, 348, 358, 360, 361	Hero	174, 181, 244
All Around	68, 204	Hikari	58, 106, 128
Altea	192	Hineri	58, 102, 216, 258, 367
Amazonia	184, 328, 353	Host	296, 324
Amiral bookcase	148, 160	Houdini	296, 336, 340, 343, 338
Amiral mirror	318	Hug	315
Amorfo	22, 102, 168, 258	Ibla	148, 150
Annette	296, 297, 298, 299	Ina	194
Anthology	200, 257, 258	Inside	106
Apsara	85, 87, 215, 346, 350	Hug	315
Area	94, 106, 120, 184, 186-184	Karphi	158-168-170
Atena	22, 2091, 292	Karphi Nap	92-94
Athene	168	Kendama	58, 271, 319
Attitude	31, 32	Kiri	258, 367
Aura	286, 288	Koi	281, 350
Bar Tender	108, 134	Kromis	32, 85
Beyond	68, 102	Kukei	12, 184, 189, 248, 250
Bicolette	364	Janet	248, 320, 321
Blow	22	Leggio	216
Bond	158	Lady	106
Borealis	102, 204, 209, 284, 288, 309	Lazy Susan	160
Break	322, 330	Libra	42, 142, 146
Breeze	244	Ligea	42, 45
Bubbles	136, 222, 244	Light	58, 61, 92, 94
Buds	274	Liling	142, 204, 207, 286, 288, 364
Calathea	114, 220, 222, 209	Liz-bench	92
Chanterelle	68, 102, 104, 106, 158	Liz-console	106, 110
Charlotte	102, 286	Liz-valet	92, 95
Clamp	268, 315, 323, 343	Loop	330, 332, 346
Clina	204, 207	Lorelei	12, 14, 19, 58, 61
Clop	321, 346, 350, 358, 361	Marimo	72
Clori	42, 92	Mia	204, 207
Club	216	Miyabi	64
Corium	318	Mistral	120, 142, 148, 160
Cross - Over	230	Mizar	200, 203
Crystal Stone	94, 106, 108, 120, 134, 160, 286, 290, 292, 296, 298, 324	Modular	136, 200, 203
		Montecarlo	257, 258
Dia	364	Montgomery	277, 292, 305, 308, 309
Diy	184, 186, 189, 258	Moonshadow	106, 321, 367
Delphi	92	Moorea	72, 75, 79, 80, 85, 87
Domus	192, 195, 256, 321, 324	Morfeo	192
Drive	204	Move	100, 102, 363
Dual	68	Nao	92
Edward	277, 305, 304	Nastus	32, 42, 128, 158, 174
Ensō	302, 335, 336, 337	Nereide	42, 57
Eva	168	Neomeris	12, 14, 19, 42, 45, 48
Fit	244	New Kendama	192
Flamingo	296, 297, 299	Nisida	72, 79, 80, 85, 87, 239, 241
Floema	76, 102, 174, 184, 189, 241	Norah	200, 202, 268
Flora	136, 137	Ode	306
Floria	12, 14, 19, 22, 25	On Off	52, 134, 239
Frame	67, 68	Opus	229, 230
Frequence	134, 168, 305, 323	Otto	12, 102, 273
Galet	22, 270, 271, 274	Panopea	22, 25
G-Code Console	244	Ploto	42, 46, 57
G-Code Desk	222	Plume	22, 24, 25, 120, 123
G-Code Table	174, 181	Progetti	192, 195
Gea	214, 215, 241, 330, 332, 346, 348, 350, 356, 357	Progetti Fashion	142
Ghiblim	136, 138	Ray	106, 288
GK 1	76	Reiwa	64

Rift	92
Ripple	226
Roman	291, 292, 364
Round	222
Salaria	158, 222, 257, 258, 262, 322, 326
Scaleno	158, 168, 324, 326
Scirocco	32, 157, 158
Seidon	30, 31, 32
Shed	318
Shibusa	291, 292
Shighera	248, 250
Shirley	267, 318, 323
Sibilia	67, 68
Side Vibe	305
Sliver	32, 364
Skirt	76, 216, 218
Skyline	102, 320, 324
Soho	128, 257, 258, 261, 262
Solemyidae	106
Spark	58, 61, 128, 184, 186, 230
Spazio Tempo	222
Summa	106, 110, 127, 129, 230, 318,
Swing	136
Swords	192
Tamino	343
Teti	32, 35
Tiber & Tiberina	64
Tie	336
Tie XL	184, 186, 187
Tenet	134
Town	134
Trace	305
Tubes	148
Upward	12, 32, 136
Urban	222
Uyuni	318
Vanity	32, 102, 184, 189, 226
Vesper	32, 142, 271, 274
Vibe	305
Wave	364
Whisper	192
Woody	204, 207, 212
Water	2148, 158, 160



Giorgetti S.p.A.
I 20821 Meda (MB)
Via Manzoni 20
T +39 0362 75275
info@giorgetti.eu
giorgetti.eu

Photo credits:
Bianca Cedrone
Federico Cedrone
Sergio Chimenti
Simona Pesarini
Giorgio Possenti

#Giorgetti



The mark of
responsible forestry
Request our FSC® certified products

