

PRESS  
RELEASE

THIRTY  
YEARS  
BIGFOOT



FOR FURTHER PRESS INFORMATION AND  
HIGH-RESOLUTION IMAGES PLEASE CONTACT:  
Anna Schmidhauser  
T +49 (0) 69 945 4918 0  
anna.schmidhauser@e15.com

e15 celebrates thirty years of table BIGFOOT, marking its enduring significance as the quintessential solid wood table and a recognisable icon for the company. Designed in 1994 by e15 founder and architect Philipp Mainzer, a radical new simplicity characterised the design of the table leaving an indelible mark on the evolution of contemporary furniture design.

BIGFOOT, Summer 2003, New York. Photography: Mark Borthwick



London, 1994. BIGFOOT is one of the initial tables, which young architect Philipp Mainzer drafts whilst still in architectural school. One year later, in 1995, the company e15 is founded and named after the postal code of its first workshop in London's East End. The unique design of BIGFOOT marks the debut of the e15 collection, establishing a pioneering use of solid wood in its purest form whilst solidifying a circular approach as the guiding design principle for the company. Also, the e15 logo is sketched during this time by Philipp Mainzer, developed around the square silhouette of the BIGFOOT table leg, which remains unchanged to this day.

Experimenting with repurposed wood, the first versions of BIGFOOT are made from wooden planks sourced from the walls of old freight wagons. The planks are heavily grained, with cracks and knots telling the story of the tree they came from. The legs of the tables are – until today – made from heartwood, which is back then considered a waste product and not suitable for premium furniture production. e15 is adamant to change this thinking: For their solid wood designs, they aim to process the whole tree, highlighting the unique qualities of wood.

Debuting the first four e15 tables: BIGFOOT, QUERKOPF, JAPAN and PONTE, London, 1994. Photography: Elisabeth Scheder-Bieschin



Philipp Mainzer at the first e15 workshop in East London, 1994.



Back in the early 90's opting for solid oak was an unusual choice of material for another reason: At the time, the market favoured slick Italian designs in smooth, lacquered surfaces, often with glass and metal finishes. This made the use of raw European oak a minor revolution.

"We first showed BIGFOOT at IMM Cologne in 1996, where the general impression was one of surprise and curiosity – solid oak with natural knots and splits was considered as reject quality at the time. Yet BIGFOOT's design underlined and celebrated the pure use of the material. We also realized that no one would walk past our stand without stroking the surface of the table. Wood is a basic and historic material with emotional appeal in furniture making. It is alive and breathing even when it has been formed into a shape. People like the warmth and honesty of solid wood. They like to touch it. This intuitive desire along with the authentic character of the table has made BIGFOOT an enduring piece over the years."

Philipp Mainzer

First sketches of e15 logo and BIGFOOT by Philipp Mainzer, 1994.

LONDON E15

E15

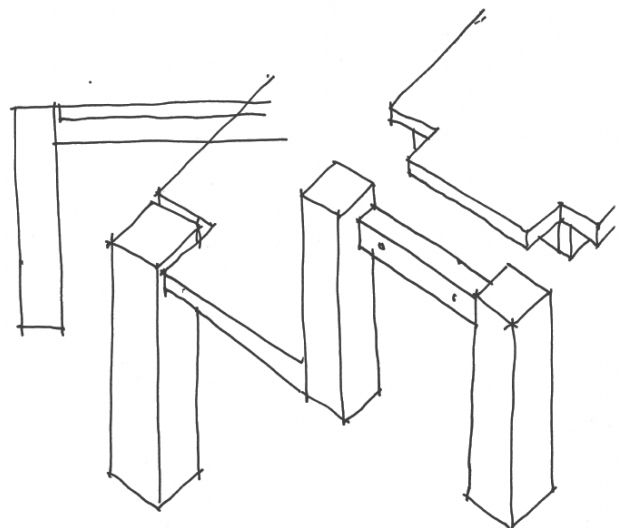
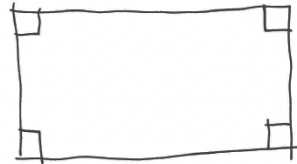

Oak is a fundamental material for e15, resonating with the spirit of the brand at its core: to produce progressive and enduring products made from high-grade materials coupled with refined craftsmanship and sustainable manufacturing. Still today, e15 uses almost all parts of the tree for the production of BIGFOOT. In line with this approach, Philipp Mainzer designed the iconic BACKENZAHN stool to make use of the off cuts from the production of BIGFOOT.

All solid wood materials at e15 originate from sustainable and certified woods, primarily from Germany. Regional production reduces the transportation footprint to a minimum. A trusted network of local craftsmen and suppliers ensures the consistent high quality of the production and ensures the biggest commitment to sustainability, which is longevity of the product. Most of e15's wood finishes are only oiled, to preserve the natural character of the product and to protect the environment from additional substances.



## ABOUT BIGFOOT

The signature tabletop of BIGFOOT is made of equal sized boards. The square shaped legs, intersect with the tabletop featuring the end grain with its annual growth rings. They form the distinct corner detail exposing the cross section of the legs, which features the centre of the tree. During the seasoning of solid wood, the legs form their characteristic cracks, which make every table unique.

To verify authenticity beyond the visual quality of material, construction and proportion, all BIGFOOT tables are branded with the e15 logo as well as an individual serial number, which can be tracked for proof of origin. For the anniversary year, each BIGFOOT table is also branded with Philipp Mainzer's signature and is accompanied by a complementary BACKENZAHN stool.

Photography: Ingmar Kurth



ABOUT  
PHILIPP  
MAINZER

Born in Germany, Philipp Mainzer studied product design at Central Saint Martins College of Art and Design, and architecture at the Architectural Association both in London. In 1995, Philipp Mainzer co-founded the furniture brand e15. He has received international awards for many of his designs, which are identifying icons for e15 and part of several permanent museum collections.

Parallel to the creation of e15, Philipp Mainzer practiced architecture in New York and continues to do so since his return to Germany in 2001. He is a member of the executive committee of German Design Council and honorary member of the Deutsche Designer Club. Having established the progressive and enduring appeal of e15 with Farah Ebrahimi, his partner and art director, Philipp Mainzer is creative and managing director of the brand and PMO, his office for architecture and design.

Photography: Boris Breuer



## ABOUT E15

e15 prides in a coherent collection of progressive furniture, lighting and accessories that bridge between private and public spaces. e15 is based in Frankfurt with its headquarters conveniently close to the specialised workshops and suppliers in Europe, primarily in Germany. A clear, unmistakable design language and consistent product philosophy resonate in collaborations with artists, designers, and architects from around the world.

With essential forms highlighting natural characteristics visible in design classics such as table BIGFOOT (1994) and stool BACKENZAHN (1996), e15 has established a leading reputation for the pioneering use of solid wood in its purest form, whilst embodying original design and sustainable production.

e15 headquarters in Frankfurt, including offices, logistics, showroom.

