



esperia®

PRISMA

2024



## Esperia

---

**IT.** "Esperia è il nome con cui i Greci originariamente designarono le terre occidentali dalla parte di Espero (vesper = sera), dove tramonta il sole. Il nome ebbe inoltre fortuna presso i poeti latini per i quali indicò l'Italia."

---

**FR.** « Esperia » (Hespérie) est le nom avec lequel les Grecs, à l'origine, désignaient l'ouest, dans la direction d'Hespéros (vesper = soir), où le soleil se couche. En outre, ce nom fut particulièrement usité par les poètes latins, qui l'utilisaient pour indiquer l'Italie.

---

**DE.** "Mit Esperia bezeichneten die Griechen ursprünglich die Länder im Westen, dort wo die Sonne abends untergeht (Hesperus, Vesper = Abend). Der Name war auch bei den lateinischen Dichtern beliebt als Bezeichnung für Italien."

**EN.** "Hesperia is the name with which the Greeks originally designated the western lands on the side of Hesperus (vesper = evening), where the sun sets. The term was also widely applied by Latin poets to indicate Italy."

---

**ES.** "Esperia es el nombre con el que los Griegos originalmente designaron las tierras occidentales del lado de Hesperia (vesper = atardecer), donde se pone el sol. El nombre tuvo además éxito entre los poetas latinos, para quienes se refería a Italia."

# Indice

— Index

00

PRISMA

5 ESPERIA  
1952-2023

01

TIMELESS ICONS

26 GIRAFFA  
40 6038  
46 GASPARE  
50 BARNABA  
56 NATALIA  
64 ASTRID

02

MODERN ICONS

68 TRASLA  
86 ERIDANIA  
105 PANDORA  
112 PULSAR  
120 VEGA  
140 COMETA  
144 SUPERNOVA  
154 EIRENE  
168 DAPHNE  
178 KIT  
182 DIVA  
190 LEILA  
196 DIANA

03

MATERICA

202 DUE PIASTRE  
204 TRE PIASTRE  
206 TEA  
208 SASSONE  
210 GALILEO  
212 PITAGORA  
214 PULCINELLA  
216 MARGOT  
218 MIDA  
220 HEROD  
222 POTTER  
224 GRU  
226 LUCY  
227 OMAK  
228 WILLOW 8  
230 PITAGORA WALL  
232 GONG  
234 METEORITE  
236 MEZZA SPERA  
238 XENON SUSPENSION  
239 ARGO SUSPENSION  
240 ARGO  
242 ELIO  
244 XENON WALL-CEILING  
246 QUASARS

04

CUSTOM ICON

263 CREALA TUA  
LAMPADA ICONICA



 **esperia**<sup>®</sup>

PRISMA

1952-2024



## Un tempio di luce, dal 1952.

---

**IT.** Lasciate che "luce" diventi un nuovo sinonimo di "bellezza", per trasformare ogni ambiente in un tempio di luce.

Esperia produce illuminazione decorativa di alta gamma dal 1952 in Toscana. Design, materia, arte ed innovazione. Questi sono i nostri valori.

E' da questi valori che creiamo oggetti senza compromessi, per dare l'opportunità a chi li sceglie di vivere emozioni incomparabili, ogni sera.

## Un temple de lumière, depuis 1952.

---

**FR.** Laissez que « lumière » devienne un nouveau synonyme de « beauté », pour transformer chaque atmosphère en un temple de lumière.

Esperia produit en Toscane des appareils d'éclairage décoratifs haut de gamme depuis 1952.

Design, matière, art et innovation. Voici nos valeurs.

C'est à partir de ces valeurs que nous créons des objets inouïs, pour offrir la possibilité à ceux qui les choisissent de vivre des émotions extraordinaires, chaque soir.

## Ein Tempel des Lichts, seit 1952.

---

**DE.** Lassen Sie Licht zum neuen Synonym für Schönheit werden, um jede Umgebung in einen Tempel des Lichts zu verwandeln.

Esperia produziert seit 1952 hochwertige dekorative Beleuchtung in der Toskana. Design, Material, Kunst und Innovation. Das sind unsere Werte.

Mit diesen Werten schaffen wir kompromisslose Objekte, so dass alle, die sich für sie entscheiden, jeden Abend unvergleichliche Emotionen erleben können.

## A temple of light, since 1952.

---

**EN.** Let "light" become a new synonym for "beauty", to transform any setting into a temple of light.

Esperia has been producing high-end decorative light fittings since 1952, in Tuscany. Design, material, art and innovation. These are our values. Starting from these values, we create objects without compromise, to offer those who choose them the opportunity to experience incomparable emotions, every evening.

## Un templo de luz, desde 1952.

---

**ES.** Que "luz" se convierta en un nuevo sinónimo de "belleza" para transformar cada ambiente en un templo de luz.

Esperia produce iluminación decorativa de alta gama desde 1952, en Toscana.

Diseño, materia, arte e innovación. Estos son nuestros valores. Es a partir de estos valores que creamos objetos sin igual, para dar a quienes los eligen la oportunidad de experimentar emociones incomparables, cada noche.



## Oltre 70 anni di esperienza

---

**IT.** Poggibonsi, 1952. Tre giovani amici intraprendenti avviarono un progetto per realizzare il loro sogno di creare un'azienda nell'Italia del dopoguerra.

L'azienda esprime fin da subito un saldo legame con il distretto toscano, dedito storicamente al settore del vetro e successivamente anche a quello dell'arredamento.

A partire dagli anni 60 espanse la sua produzione a tutto il settore illuminotecnico, grazie ad un importante sviluppo strutturale e produttivo.

Negli stessi anni Esperia diede inizio ad una proficua e duratura collaborazione con il Prof. Angelo Brotto.

Appartengono a questo periodo le prime esposizioni, e il debutto dell'azienda al Salone del Mobile di Milano con la partecipazione ad Euroluce nel 1969, la prima di una lunga serie.

Questo consentì al marchio di raggiungere una importante notorietà internazionale e di dare inizio a nuove collaborazioni con aziende leader dell'arte vetraria come Venini.

Il centro stile interno di Esperia progetta e realizza le creazioni, incluso il settore custom, controllando tutto il processo produttivo che si articola nei vari distretti toscani.

Oggi Esperia è un'azienda d'eccellenza, impegnata quotidianamente nella ricerca e nello sviluppo di progetti innovativi e contemporanei, grazie all'esperienza maturata nel corso di oltre 70 anni di storia.

## Over 70 years of experience

---

**EN.** Poggibonsi, 1952. Three enterprising young friends started a project to follow their dream of establishing a company in post-war Italy.

The company immediately expressed a strong bond with the Tuscan district, historically dedicated to the glass manufacturing sector and, later, to the furniture sector as well.

Starting from the 1960's, it expanded its production to the entire lighting technology sector, through an important structural and productive development.

In the same years, Esperia began a fruitful and lasting collaboration with Prof. Angelo Brotto.

The first exhibitions date back to this period, including the company's debut at the Salone del Mobile, the international furniture fair held in Milan, with its participation in Euroluce in 1969, the first of a long series.

This enabled the brand to gain an important international reputation and to start new collaborations with leading glassmaking companies such as Venini.

Esperia's in-house style centre designs and manufactures the creations, including the custom-made sector, controlling the entire production process distributed in the various Tuscan districts.

Thanks to the experience gained over more than 70 years of history, Esperia is now a company of excellence, fully committed to the research and development of innovative and contemporary projects.



## Plus de 70 ans d'expérience

---

**FR.** Poggibonsi, 1952. Trois jeunes amis entrepreneurs lancèrent un projet pour réaliser leur rêve de fonder une entreprise dans l'Italie de l'après-guerre.

L'entreprise affirma tout de suite son lien solide avec le district toscan, qui s'occupe depuis toujours du secteur du verre, puis de celui du meuble.

À partir des années 60, elle étendit sa production à tout le secteur de l'éclairagisme, grâce à un important développement structurel et productif.

À cette même époque, Esperia commença une collaboration fructueuse et durable avec le professeur Angelo Brotto.

C'est aussi l'époque des premières expositions. L'entreprise fait ses premiers pas au Salon du Meuble de Milan, en participant à Euroluce en 1969, la première participation d'une longue série.

Cela permit à la marque de connaître une importante notoriété à l'international et d'instaurer de nouvelles collaborations avec des entreprises leader dans le domaine de l'art verrier, comme Venini.

Le bureau d'études interne d'Esperia conçoit et réalise les créations, secteur custom compris, contrôlant l'intégralité du procédé de production, qui s'articule sur les différents districts toscans.

Aujourd'hui, Esperia est une entreprise d'excellence, engagée chaque jour dans la recherche et le développement de projets novateurs et actuels, grâce à l'expérience acquise au cours de ses plus de 70 ans d'histoire.

## Más de 70 años de experiencia

---

**ES.** Poggibonsi, 1952. Tres jóvenes amigos emprendedores pusieron en marcha un proyecto para hacer realidad su sueño de crear una empresa en la Italia de la posguerra.

La empresa entabló de inmediato un sólido vínculo con la región toscana, dedicada históricamente al sector del vidrio y luego también al sector de la decoración.

A partir de los años 60 expandió su producción a todo el sector luminotécnico, gracias a un importante desarrollo estructural y productivo.

En esos mismos años Esperia dio inicio a una fructífera y duradera colaboración con el Prof. Angelo Brotto.

A ese período corresponden las primeras exposiciones y el debut de la empresa en el Salón del Mueble de Milán, con la participación en Euroluce en 1969, la primera de una larga serie.

Ello permitió que la marca alcanzara una importante notoriedad internacional y diera inicio a nuevas colaboraciones con empresas líderes en el arte en vidrio, como Venini.

El centro de estilo interno de Esperia diseña y realiza las creaciones, incluido el sector a medida, controlando todo el proceso de producción, que se articula en diferentes zonas de Toscana.

Hoy en día Esperia es una empresa de excelencia, comprometida cotidianamente en la investigación y en el desarrollo de proyectos innovadores y contemporáneos, gracias a la experiencia alcanzada a lo largo de más de 70 años de historia.

## Mehr als 70 Jahre Erfahrung

---

**DE.** Poggibonsi, 1952. Drei junge, unternehmungslustige Freunde starten ein Projekt, um im Italien der Nachkriegszeit ihren Traum von der Gründung eines Unternehmens zu verwirklichen.

Das Unternehmen knüpfte sofort enge Kontakte mit der regionalen Wirtschaft, die historisch von der Glasherstellung und später auch von der Möbelbranche geprägt war.

Ab den 60er Jahren wurde die Produktion dank einer wichtigen strukturellen und produktiven Entwicklung im gesamten Beleuchtungssektor erweitert.

In diesen Jahren begann Esperia eine fruchtbare und dauerhafte Zusammenarbeit mit Professor Angelo Brotto.

Die ersten Ausstellungen fanden zu jener Zeit statt, sowie das Debüt des Unternehmens auf dem Salone del Mobile in Mailand mit seiner Teilnahme an der Euroluce im Jahr 1969. Diese waren nur die ersten einer langen Reihe.

Die Marke konnte so einen bedeutenden internationalen Ruf erlangen und neue Kooperationen mit führenden Glasherstellern wie Venini eingehen.

Das Styling-Center von Esperia entwirft und fertigt die Kreationen, einschließlich des Custom-Sektors, und kontrolliert den gesamten Produktionsprozess, der an verschiedenen toskanischen Standorten stattfindet.

Heute ist Esperia ein herausragendes Unternehmen. Dank der in mehr als 70 Jahren gesammelten Erfahrung beschäftigt es sich täglich mit der Forschung und Entwicklung innovativer und zeitgemäßer Projekte.



## Materiali e lavorazioni

---

**IT.** La collezione Esperia nasce da una ricca palette di materiali.

Le nostre creazioni includono materiali nobili come il cuoio, le fusioni di ottone e di alluminio, il vetro ed il cristallo di Colle Val D'Elsa, lavorato dalla sapiente maestria degli artigiani del nostro distretto produttivo e rappresentano la base di partenza per sculture luminose iconiche, e per realizzazioni custom dedicate a scenari retail e contract.

Da sempre impegnata nella ricerca sulle lavorazioni dei materiali al fine di ottenere risultati ricchi ed inaspettati, Esperia si avvale delle più importanti manifatture per le lavorazioni dei metalli (ferro, ottone e alluminio), del cristallo e del vetro.

Le molteplici lavorazioni sono rifinite a mano, instaurando un dialogo tra i materiali impiegati e la resa finale del manufatto.

Le finiture hanno le rese più diverse e spaziano da quelle più preziose come la foglia d'oro e la foglia d'argento, a bruniture e satinature manuali, fino ai bagni galvanici.

Mantenendo saldo il legame con la manifattura artistica, ogni lampada rappresenta una scultura unica e irripetibile, andando a definire la firma distintiva di Esperia.

## Materials and workmanship

---

**EN.** The Esperia collection originates from a rich palette of materials.

Our creations include noble materials such as leather, cast brass and cast aluminium, Colle Val d'Elsa glass and crystal, worked with masterly skill by the craftsmen of our production district and represent the starting point for iconic light sculptures and for custom-made creations for the retail and contract scenarios.

Esperia has always been committed to research on the processing of materials aimed at obtaining rich and unexpected results, and makes use of the most important manufacturers for the processing of metals (iron, brass and aluminium), as well as crystal and glass.

The multiple processes are finished by hand, establishing a dialogue between the materials used and the final result of the product.

The finishes feature the most diverse traits and range from the most precious, such as gold leaf and silver leaf, to hand burnishing and satin finishing, up to galvanising baths.

By keeping a strong bond with artistic manufacturing, each lamp represents a unique and exclusive sculpture, defining the distinctive signature of Esperia.



## Matériaux et façons

---

**FR.** La collection Esperia se décline dans une riche palette de matériaux.

Nos créations sont réalisées à partir de matériaux nobles comme le cuir, le laiton et l'aluminium coulés, le verre et le cristal de Colle Val D'Elsa, travaillés avec tout le savoir-faire expérimenté des artisans de notre district de production et constituent le point de départ pour la création de lumineuses sculptures iconiques et pour des réalisations personnalisées dédiées au secteur de la vente au détail et des collectivités.

S'occupant, depuis toujours, de travailler les matériaux afin d'obtenir des résultats riches et surprenants, Esperia se prévaut des plus importantes manufactures pour le travail des métaux (fer, laiton et aluminium), du cristal et du verre.

Les multiples façons sont finies à la main, instaurant un dialogue entre les matériaux utilisés et le rendu final de l'objet.

Les finitions présentent des rendus très différents et vont de celles plus précieuses, comme la feuille d'or et la feuille d'argent, à des brunissages et des satinages manuels, sans oublier les bains galvaniques.

Tout en gardant solide le lien avec la manufacture artistique, chaque lampe se présente comme une sculpture unique et inimitable, définissant la marque de fabrique d'Esperia.

## Materiales y procesos

---

**ES.** La colección Esperia nace de una rica paleta de materiales.

Nuestras creaciones incluyen materiales nobles como el cuero, el latón y el aluminio fundidos, el vidrio y el cristal de Colle Val D'Elsa, transformados con la sabia maestría de los artesanos de nuestra región de producción y representan el punto de partida para esculturas luminosas emblemáticas y para realizaciones a medida destinadas a escenarios retail y contract.

Desde siempre comprometida en la investigación sobre las transformaciones de los materiales a fin de obtener resultados ricos e inesperados, Esperia se vale de las manufactureras más importantes para la transformación de los metales (hierro, latón y aluminio), del cristal y del vidrio.

Los múltiples procesos se terminan a mano, estableciendo un diálogo entre los materiales empleados y el resultado final de la manufactura.

Los acabados tienen los más diversos rendimientos y varían desde los más preciosos, como el pan de oro y el pan de plata, pasando por pulidos y satinados manuales, hasta los baños galvánicos.

Al mantener fuertes vínculos con la manufactura artística, cada lámpara representa una escultura única e irrepetible, lo que define la firma distintiva de Esperia.

## Materialien und Arbeitsprozesse

---

**DE.** Die Kollektion von Esperia verwendet eine reiche Palette von Materialien.

Diese Materialien, wie die Messingussteile und das Kristall aus Colle Val D'Elsa, ein Markenzeichen von Esperia, werden von den Kunsthandwerkern der Region auf geschickte Weise bearbeitet und bilden den Ausgangspunkt für ikonische Leuchtskulpturen, kundenspezifische Kreationen und Objekte für die Sektoren Retail und Contract.

Seit jeher forscht Esperia auf dem Gebiet der Materialverarbeitung, um neue, innovative Ergebnisse zu erzielen. Dabei nutzt das Unternehmen die wichtigsten Hersteller für die Verarbeitung von Metallen (Eisen, Messing und Aluminium), Kristall und Glas.

Die zahlreichen Bearbeitungsprozesse werden von Hand ausgeführt und stellen einen Dialog zwischen den verwendeten Materialien und dem Endergebnis des Produkts her.

Die Veredelung der Oberflächen erfolgt auf unterschiedlichste Art, von den edelsten Techniken wie Blattgold und Blattsilber über manuelles Brünieren und Satinieren bis hin zu galvanischen Bädern.

Jede Leuchte ist Zeugnis der engen Verbindung zum Kunsthandwerk und stellt eine einzigartige und unwiederholbare Skulptur dar, die die unverwechselbare Handschrift von Esperia definiert.

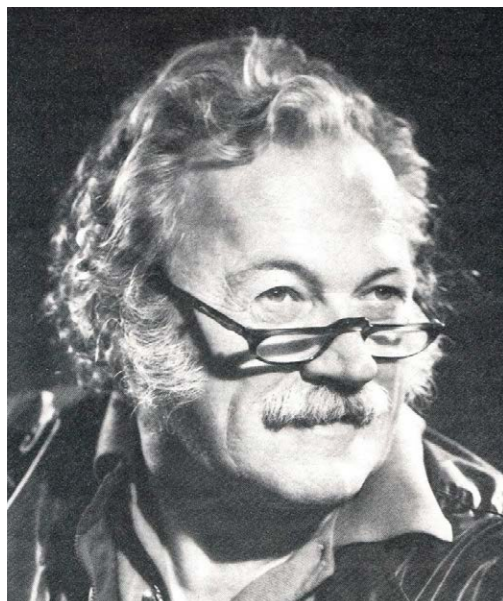

## Angelo Brotto

Artista e designer

**IT.** La forte attenzione che Esperia nutriva per il Design contemporaneo portò ad un'importante collaborazione Angelo Brotto (1914, Venezia - 2002 Campiglia Marittima).

Laureato nel 1941 all'Accademia di Belle Arti di Venezia, fu un importante artista e designer italiano e partecipò a diverse Biennali d'Arte e mostre internazionali, vincendo numerosi premi.

La direzione creativa del Prof. Brotto iniziò nel 1958 e si protrasse per oltre 20 anni, generando un rapporto esclusivo con Esperia che portò ad un legame di profonda amicizia con Romano Conforti, uno dei fondatori di Esperia.

Tutta la produzione Esperia firmata Angelo Brotto è caratterizzata da una grande sensibilità progettuale, e il suo intervento artistico catturò il gusto dell'epoca con forme ed accostamenti inediti. Il suo lavoro di direzione creativa, caratterizzato da un approccio non convenzionale frutto della formazione accademica del professore, diede infatti vita ad un vasto catalogo di lampade che spaziava da opere di più facile lettura fino a creazioni artistiche vere e proprie.

Alcune di queste, i Quasar per esempio, divennero nel corso degli anni veri e propri oggetti di culto ed oggi molto ambiti dai collezionisti.

Durante la lunga collaborazione con Esperia, furono affrontati e sviluppati temi che impiegavano materiali molto eterogenei: fusione artistica di ottone, perspex e in particolare il vetro di Murano, materiale molto caro al Prof. Brotto con il quale realizzò alcune delle più importanti lampade della collezione.

Artist and designer

**EN.** Esperia's deep interest in contemporary design led to an important collaboration with Angelo Brotto (1914, Venice - 2002, Campiglia Marittima).

Brotto graduated in 1941 from the Academy of Fine Arts in Venice. He was an important Italian artist and designer and participated in several Art Biennials and international exhibitions, winning numerous awards.

Prof. Brotto's creative direction began in 1958 and lasted for over 20 years, giving life to an exclusive relationship with Esperia, which led to a bond of true friendship with Romano Conforti, one of Esperia's founders.

Esperia's entire production by Angelo Brotto is marked by a great sensitivity for design, and his artistic intervention captured the taste of the time, generating unprecedented shapes and combinations. His work of creative direction, distinguished by an unconventional approach resulting from his academic background, brought to the creation of a vast catalogue of lamps that ranged from easier-to-interpret works to real pieces of art.

The latter include, for example, the Quasars, which over the years have become real cult objects coveted by today's collectors.

During his long collaboration with Esperia, themes were tackled and developed using very heterogeneous materials: artistic cast brass, Perspex and, in particular, Murano glass, a material very dear to Prof. Brotto, with which he created some of the most important lamps in the collection.



E DEL MOBILE ITALIANO 1975 - MILANO

FOTOTECNICA APRILE  
Via Cesare da Sesto 2



## Artiste et designer

---

**FR.** Esperia a toujours attaché une forte attention au Design contemporain, si bien qu'elle instaura une importante collaboration avec Angelo Brotto (1914, Venise – 2002, Campiglia Marittima).

Diplômé en 1941 à l'Académie des Beaux-Arts de Venise, ce fut un important artiste et designer italien, qui participa à différentes Biennales d'Art et expositions internationales, remportant de nombreux prix.

La direction créative du professeur Brotto débuta en 1958 et dura plus de 20 ans, donnant vie à un rapport exclusif avec Esperia, qui déboucha sur un lien de profonde amitié avec Romano Conforti, l'un des fondateurs d'Esperia.

Toute la production d'Esperia signée Angelo Brotto est caractérisée par une grande sensibilité de projet, et son intervention artistique séduit les goûts de l'époque avec des formes et des associations insolites. Son travail de direction créative, caractérisé par une approche non conventionnelle, fruit de la formation académique du professeur, donna en effet vie à un vaste catalogue de lampes, embrassant des œuvres de lecture plus facile jusqu'à des créations artistiques proprement dites.

Certaines d'entre elles, les Quasar par exemple, devinrent au fil du temps de véritables objets de culte et sont très recherchées, à l'heure actuelle, par les collectionneurs.

Au cours de sa longue collaboration avec Esperia furent affrontés et développés des thèmes qui gravitaient autour de matériaux très hétérogènes : laiton moulé de façon artistique, Perspex® et notamment le verre de Murano, un matériau auquel le professeur Brotto tenait tout particulièrement et avec lequel il réalisa certaines des plus importantes lampes de la collection.

## Artista y diseñador

---

**ES.** La fuerte atención que Esperia prestaba al diseño contemporáneo llevó a una importante colaboración con Angelo Brotto (1914, Venecia - 2002 Campiglia Marittima).

Graduado en 1941 en la Academia de Bellas Artes de Venecia, fue un importante artista y diseñador italiano, que participó en diferentes Bienales de Arte y muestras internacionales, obteniendo numerosos premios.

La dirección creativa del Prof. Brotto comenzó en 1958 y se extendió por más de 20 años, generando una relación exclusiva con Esperia que llevó a un vínculo de profunda amistad con Romano Conforti, uno de los fundadores de Esperia.

Toda la producción de Esperia con la firma de Angelo Brotto se caracteriza por una gran sensibilidad de diseño y su intervención artística capturó el gusto de la época, con formas y combinaciones inéditas. Su trabajo de dirección creativa, caracterizado por un enfoque no convencional, fruto de la formación académica del profesor, dio origen a un vasto catálogo de lámparas que abarcaba desde obras de fácil lectura hasta verdaderas creaciones artísticas.

Algunas de ellas, las Quasar, por ejemplo, se transformaron, a lo largo de los años, en verdaderos objetos de culto, hoy muy codiciados por los coleccionistas.

Durante la prolongada colaboración con Esperia, se abordaron y desarrollaron temas que empleaban materiales muy heterogéneos: fundición artística de latón, perspex y, en particular, el cristal de Murano, material muy apreciado por el Prof. Brotto, con el cual realizó algunas de las lámparas más importantes de la colección.

## Künstler und Designer

---

**DE.** Das starke Engagement von Esperia für zeitgenössisches Design führte zu einer wichtigen Zusammenarbeit mit Angelo Brotto (1914, Venedig - 2002, Campiglia Marittima).

Dieser bedeutende italienische Künstler und Designer machte 1941 seinen Abschluss an der Akademie der Schönen Künste in Venedig und nahm an mehreren Kunstbiennalen und internationalen Ausstellungen teil, auf denen er zahlreiche Preise gewann.

Die kreative Leitung durch Professor Brotto begann 1958 und dauerte über 20 Jahre. Dadurch entstand eine exklusive Beziehung zu Esperia, die zu einer tiefen Freundschaft mit Romano Conforti, einem der Gründer von Esperia, führte.

Die gesamte Esperia-Produktion von Angelo Brotto zeichnet sich durch eine große gestalterische Sensibilität aus. Seine künstlerische Handschrift traf mit beispiellosen Formen und Kombinationen den Geschmack der Zeit. Seine kreative Leitung, gekennzeichnet durch einen unkonventionellen Ansatz, der aus der akademischen Ausbildung resultierte, schuf einen umfangreichen Katalog von Leuchten, der von leichter lesbaren Werken bis hin zu wahren Kunstwerken reichte.

Einige davon, zum Beispiel die Serie Quasar, wurden im Laufe der Jahre zu echten Kultgegenständen und sind heute bei Sammlern sehr begehrt.

Während der langen Zusammenarbeit mit Esperia wurden Themen bearbeitet und entwickelt, die sehr heterogene Materialien umfassten, darunter die künstlerische Verbindung von Messing, Plexiglas und insbesondere Muranoglas, ein Material, das Professor Brotto sehr am Herzen lag, und mit dem er einige der wichtigsten Leuchten der Sammlung herstellte.

 **esperia**<sup>®</sup>

# Catalogue

2024



01

## TIMELESS ICONS

GIRAFFA  
6038  
GASPARE  
BARNABA  
NATALIA  
ASTRID



# GIRAFFA

2023 LED VERSION





# GIRAFFA

Design Angelo Brotto, 1971

**IT.** 1971. Genio, intuito, equilibrio.

Da un microfono televisivo mobile nasce l'idea di Brotto di creare una lampada da terra che diventerà uno dei importanti prodotti iconici di Esperia nel mondo.

E da oggi, è disponibile anche nella nuova versione a LED ed in due nuove finiture esclusive in occasione dell'anniversario 70+1 di Esperia. Bianco con dettagli in nickel nero e nero opaco con dettagli in ottone cromato.

Giraffa è una lampada da terra orientabile ed estensibile in alluminio satinato e dettagli in ottone cromato. Un sistema di contrappesi permette di posizionare la lampada in infinite configurazioni.

La struttura molto lineare e sottile, bilanciata da contrappesi a parallelepipedo, si inserisce nello spazio fino ad uno sbalzo di 250 cm: tale misura è anche il raggio dell'area che Giraffa arriva ad illuminare.

Giraffa ha un raggio di rotazione di 260°.

**EN.** 1971. Genius, intuition, balance.

A boom microphone used in TV production is what inspired Brotto's idea for a floor lamp that would become one of the important iconic products of Esperia in the world.

Giraffa is linear, elegant, slender, balanced.

Now, it is also available in the new LED version and in two new, exclusive finishes, to celebrate Esperia's 70+1 anniversary. White with black nickel details and matt black with chromed brass details.

Giraffa is an adjustable and extendable aluminium floor lamp with satin finish and chromed brass details. A system of counterweights makes it possible for the lamp to be placed in different positions.

The very linear and thin structure, balanced by parallelepiped counterweights, fits into the space up to an overhang of 250 cm: this measurement is also the radius of the area illuminated by Giraffa.

Giraffa has a radius of rotation of 260°.

## LIGHT SOURCES GIRAFFA

1x E26/E27 LED MAX30W Dimmable

## LIGHT SOURCES GIRAFFA LED

3000k/4000k - CRI>90 -35W - Dimmable-2500 lm

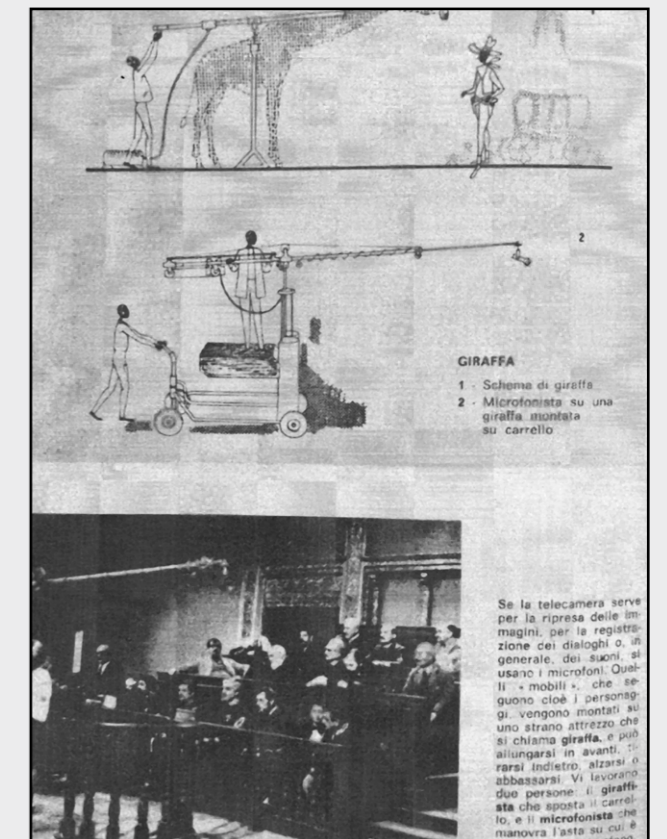
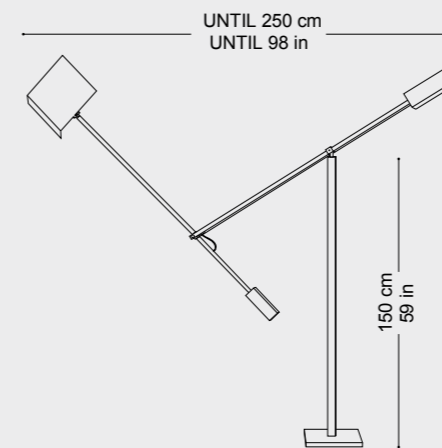

**FR. 1971. Génie, intuition, équilibre.**

C'est à partir d'un microphone de télévision mobile qu'est née l'idée de Brotto de créer une lampe à pied qui deviendra l'un des importants articles iconiques d'Esperia dans le monde. Giraffa est linéaire, élégante, fine et équilibrée.

Elle est actuellement disponible dans une nouvelle version à LED et dans deux nouvelles finitions exclusives, conçues à l'occasion du 70+1ème anniversaire d'Esperia. Blanche avec des détails en nickel noir et noir mat avec des détails en laiton chromé.

Giraffa est une lampe à pied orientable et extensible en aluminium satiné avec des détails en laiton chromé. Un système de contrepoids permet de positionner la lampe dans un nombre infini de configurations.

Très linéaire et fine, équilibrée par les contrepoids en forme de parallélépipède, sa structure s'insère dans l'espace, jusqu'à un écartement de 250 cm : c'est aussi la mesure du rayon de l'aire que Giraffa parvient à éclairer. Le rayon de rotation de Giraffa est de 260°.

**DE. 1971. Genie, Intuition, Balance.**

Inspiriert von einem mobilen Fernsehmfikrofon entstand Brottos Idee einer Stehlampe, die weltweit zu einer der bedeutendsten Ikonen von Esperia wurde. Giraffa ist geradlinig, elegant, subtil und ausgewogen. Anlässlich des 70+1-Jubiläums von Esperia ist sie nun auch in der neuen LED-Version und in zwei neuen exklusiven Lackierungen erhältlich: weiß mit Details aus schwarzem Nickel und mattschwarz mit verchromtem Messing.

Giraffa ist eine verstellbare und ausziehbare Stehleuchte aus satiniertem Aluminium mit Details aus verchromtem Messing. Ein System von Gegengewichten ermöglicht die Positionierung der Leuchte in zahllosen Konfigurationen.

Die sehr lineare und dünne Struktur, die durch Gegengewichte in Form von Parallelepipeden ausbalanciert wird, schafft einen Überhang von 250 cm im Raum: Dieses Maß ist auch der Radius der Fläche, die die Giraffa ausleuchten kann. Der Rotationsradius von Giraffa beträgt 260°.

**ES. 1971. Genialidad, intuición, equilibrio.**

A partir de un micrófono televisivo móvil nace la idea de Brotto de crear una lámpara de pie que se convertirá en uno de los productos icónicos de Esperia en el mundo. Giraffa es lineal, elegante, sutil, equilibrada.

Y, desde hoy, está disponible en la nueva versión led y en dos nuevos acabados exclusivos con motivo del aniversario 70 + 1 de Esperia. Blanco, con detalles en níquel negro y negro opaco con detalles de latón cromado.

Giraffa es una lámpara de pie orientable y extensible, de aluminio satinado y con detalles de latón cromado.

Un sistema de contrapesos permite posicionar la lámpara en infinitas configuraciones.

La estructura, muy lineal y sutil, equilibrada por contrapesos en paralelepípedo, se inserta en el espacio hasta un voladizo de 250 cm: dicha medida es también el radio del área que Giraffa llega a iluminar.

Giraffa tiene un radio de rotación de 260°.







#MeridianiLivingInteriors @meridiani.livinginteriors  
Art director: #andreaparisio  
Set designer: @l\_aura\_tocchet  
Photo: @davidelovatti





@piancadesign  
Exhibitor: Pianca  
Exhibition Design: Cristina Celestino Studio  
Styling: stanza [97.] di Elena Caponi e Paola Craca  
Photo credit: Record Studio



6038

Design Angelo Brotto, 1959

2023 LED VERSION



## 6038

Design Angelo Brotto, 1959

**IT.** Un'altra piantana visionaria e futurista di Brotto. Ogni volta che Brotto visitava Esperia per supervisionare i progressi nello sviluppo dei nuovi modelli, risiedeva nella piazza del Duomo della vicina cittadina di San Gimignano. E da qui, ispirato dalle torri della "Manhattan del medioevo", nacque la "6038". Le stesse torri ispirarono poi anche l'Architetto Minoru Yamasaki per la realizzazione del World Trade Center a NY. Il fotografo italiano Tony Vaccaro, incaricato dalla rivista Life di presentare in anteprima ai newyorkesi il progetto, passò alcuni giorni in compagnia dell'architetto giapponese. *"Qualcosa di italiano c'era già nel progetto delle Torri. Yamasaki si era ispirato al Palazzo del Doge di Venezia e alle torri di San Gimignano: così mi aveva spiegato. Le foto furono poi pubblicate da LIFE il 22 marzo del 1969".* Oggi, nell'anniversario del 70+1 di Esperia, "6038" rinasce in una nuova edizione che si affianca all'originale. Il nero opaco ed il rosso lasciano il posto ad una finitura cromata, ed il plexiglass si trasforma in una lastra di vetro acidato. È sempre Lei, ma è completamente nuova.

**EN.** Another visionary and futurist floor lamp by Brotto. Whenever Brotto visited Esperia to oversee the progress in developing new models, he stayed in the Piazza del Duomo in the nearby town of San Gimignano. "6038" was conceived there, inspired by the towers of the "Medieval Manhattan". Those same towers also inspired Architect Minoru Yamasaki for the construction of the World Trade Center in NY. The Italian photographer Tony Vaccaro, commissioned by Life magazine to present a preview of the project to New Yorkers, spent a few days in the company of the Japanese architect. *"There was already something Italian in the project of the Towers. Yamasaki was inspired by Palazzo del Doge in Venice and the towers of San Gimignano: so he explained to me. The photos were then published by LIFE on 22 March 1969".* Today, on Esperia's 70+1 anniversary, "6038" takes on a new life with a different edition that complements the original. The matt black and red give way to a chrome finish, while the Plexiglass is replaced by an etched glass sheet. It is still the same, with a completely new look.



original version



**FR.** Une autre lampe à pied visionnaire et futuriste de Brotto.

Chaque fois que Brotto visitait Esperia pour superviser les progrès dans le développement des nouveaux modèles, il séjournait sur la place du Dôme, dans la petite ville voisine de San Gimignano.

C'est ici que, puisant son inspiration des tours de la « Manhattan du Moyen-âge », naquit la « 6038 ».

Ces mêmes tours furent aussi la source d'inspiration de l'architecte Minoru Yamasaki pour la réalisation du World Trade Center de NY. Chargé par la revue Life de présenter en avant-première le projet aux new-yorkais, le photographe italien Tony Vaccaro passa quelques jours en compagnie de l'architecte japonais.

« Il y avait déjà quelque chose d'italien dans le projet des Tours. Yamasaki s'était inspiré du palais des Doges de Venise et des tours de San Gimignano : c'est lui qui me l'avait expliqué. Les clichés furent ensuite publiés par LIFE le 22 mars 1969 ».

Aujourd'hui, à l'occasion de l'anniversaire des 70+1 ans d'Esperia, « 6038 » renaît dans une nouvelle version, qui accompagne l'original. Le noir mat et le rouge laissent place à une finition chromée, et le plexiglas se transforme en une plaque de verre dépoli.

C'est toujours elle, mais elle est complètement renouvelée.

**ES.** Otra lámpara de pie visionaria y futurista de Brotto.

Cada vez que Brotto visitaba Esperia para supervisar los avances en el desarrollo de los nuevos modelos, residía en la plaza del Duomo de la cercana ciudad de San Gimignano.

Y de allí, inspirado por las torres de la "Manhattan de la Edad Media", surgió "6038".

Las mismas torres inspiraron posteriormente al arquitecto Minoru Yamasaki para la construcción del World Trade Center en Nueva York. El fotógrafo italiano Tony Vaccaro, encargado por la revista Life para presentar en primicia el proyecto a los neoyorquinos, pasó unos días en compañía del arquitecto japonés.

"Había algo italiano ya en el diseño de las Torres. Yamasaki se había inspirado en el Palacio Ducal de Venecia y en las torres de San Gimignano: así me lo explicó. Las fotos fueron publicadas por LIFE el 22 de marzo de 1969".

Hoy en día, en el aniversario número 70 + 1 de Esperia, "6038" renace en una nueva edición, que se une a la original. El negro opaco y el rojo dejan lugar a un acabado cromado, y el plexiglas se transforma en una hoja de vidrio grabado al ácido.

Sigue siendo Ella, pero es completamente nueva.

**DE.** Eine weitere visionäre und futuristische Stehleuchte von Brotto.

Wenn Brotto Esperia besuchte, um den Fortschritt bei der Entwicklung der neuen Modelle zu überwachen, wohnte er an der Piazza del Duomo in der nahe gelegenen Stadt San Gimignano.

Hier entstand die Idee zum Modell „6038“, inspiriert von den Türmen des „Manhattan des Mittelalters“.

Diese Türme inspirierten ebenfalls den Architekten Minoru Yamasaki beim Bau des World Trade Centers in New York. Der italienische Fotograf Tony Vaccaro, der vom Life Magazine beauftragt wurde, das Projekt den New Yorkern im Vorfeld zu präsentieren, verbrachte einige Tage in der Gesellschaft des japanischen Architekten.

„Etwas Italienisches war bereits im Projekt der Twin Towers vorhanden. Yamasaki ließ sich vom Dogenpalast in Venedig und den Türmen von San Gimignano inspirieren: so erklärte er es mir. Die Fotos wurden dann am 22. März 1969 von LIFE veröffentlicht.“

Heute, zum 70 + 1-Jubiläum von Esperia, wird „6038“ in einer Neuauflage wiedergeboren, die sich dem Original anschließt. Das matte Schwarz und Rot weicht einem Chrom-Finish, und das Plexiglas verwandelt sich in eine geätzte Glasplatte.

Immer noch dieselbe Leuchte, aber völlig neu.

**DIMENSION**

Height: H 180 cm / 71 In

**LIGHT SOURCES**

3000k/4000k - CRI>90 - 85W  
Dimmable-6500 lm



San Gimignano



GASPARE  
Design Angelo Brotto, 1970



# GASPARE

Design Angelo Brotto, 1976

**IT.** Disegnato nel 1970 da Angelo Brotto, "Gaspare" rappresentò in quel periodo una grande innovazione dal punto di vista del design, che tracciò una linea importante nello stile di Esperia a cui seguirono appunto molti altri modelli. Il cono è in alluminio satinato, il diffusore in plexiglass, ed il cilindro in metallo nero opaco.

**FR.** Conçue en 1970 par Angelo Brotto, « Gaspare » représente à cette époque une grande innovation en termes de design, qui posa un jalon important dans le style d'Esperia et auquel suivirent de nombreux autres modèles. Le cône est en aluminium satiné, le diffuseur en plexiglass et le cylindre en métal noir mat.

**DE.** Das 1970 von Angelo Brotto entworfene Modell „Gaspare“ stellte damals eine große Innovation aus gestalterischer Sicht dar, die eine wichtige Linie in das Styling von Esperia einbrachte, der viele andere Modelle folgten. Der Kegel besteht aus satiniertem Aluminium, der Diffusor aus Plexiglas und der Zylinder aus mattschwarzem Metall.

**EN.** Designed in 1970 by Angelo Brotto, at that time "Gaspare" represented a great innovation in design and traced an important line in Esperia's style, followed by many other models. The cone is of aluminium with satin finish, the diffuser is of Plexiglass, and the cylinder is of matt black metal.

**ES.** Diseñada en 1970 por Angelo Brotto, "Gaspare" representó en ese período una gran innovación desde el punto de vista del diseño, que trazó una línea importante en el estilo de Esperia, al que, de hecho, siguieron muchos otros modelos. El cono es de aluminio satinado, el difusor de plexiglas y el cilindro de metal negro opaco.

## DIMENSION

Height: 100 cm / 39 In

## LIGHT SOURCES

4x GU10 LED + 3x G9 LED

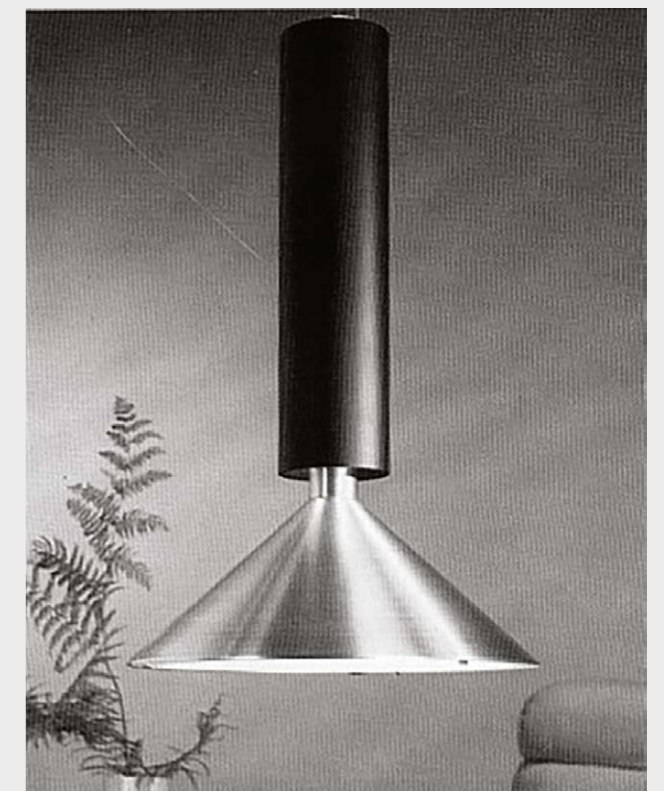
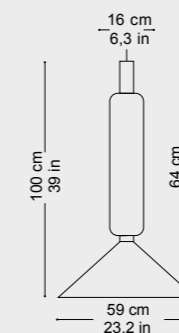

Image from the original catalog



# BARNABA

Design Angelo Brotto, 1974



# BARNABA

Design Angelo Brotto, 1974

**IT.** Barnaba. Una lampada, una galassia.

La lampada da tavolo nelle collezioni Esperia che può essere definita a pieno titolo una vera scultura di luce moderna. Più di tutti gli altri modelli, Barnaba ha tracciato un segno fondamentale nel nostro stile. Disegnata nel 1974, racchiude in sé 3 caratteristiche che tutt'oggi sono firme distintive del nostro marchio. L'unione del vetro con l'ottone, la decorazione "sabbia" del vetro, e gli "anelli".

Questa lampada scultura è composta da una base che nasconde la fonte luminosa da cui partono una raggiera di tondini metallici a disegnare diversi diametri.

Sopra la fonte luminosa è posizionato un vetro artistico realizzato a mano.

Vetro artistico realizzato a mano di circa 7kg.

**EN.** Barnaba. A lamp, a galaxy.

The table lamp in Esperia's collections that can rightfully be defined as a real modern light sculpture. More than all the other models, Barnaba has left a fundamental mark in our style.

Designed in 1974, it embodies three characteristics that are still distinctive traits of our brand.

The combination of glass and brass, the "sanded" glass decoration, and the "rings".

This sculpture lamp has a base that hides the light source, to which metal halos of different diameters are attached. Above the light source there is an artistic, handmade crystal.

Handmade artistic glass of about 7 kg.

## DIMENSION

Height: H 68 cm / 27 In  
 Diameter: 52 cm / 20,5 In  
 Weight: 11 kg / 24 lb

## LIGHT SOURCES

1x E27/E26 Max 30W

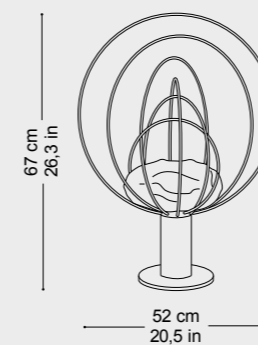

Image from the original catalog



**FR.** Barnaba. Une lampe, une galaxie.

La lampe de table des collections Esperia qui peut être qualifiée à plein titre de sculpture de lumière moderne. Plus que tous les autres modèles, Barnaba a profondément marqué notre style. Conçue en 1974, elle rassemble trois caractéristiques qui, à l'heure actuelle, sont des empreintes distinctives de notre maison.

L'alliance du verre avec le laiton, le verre sablé et les anneaux.

Cette lampe-sculpture se compose d'une base qui dissimule la source lumineuse de laquelle part un rayon de cercles en métal, dessinant différents diamètres. Au-dessus de la source lumineuse est positionnée une pièce de verre artistique réalisée à la main.

Verre artistique réalisé à la main d'environ 7 kg.

**DE.** Barnaba. Eine Leuchte, eine Galaxie.

Die Tischleuchte in der Esperia-Kollektion, die man als echte moderne Lichtskulptur definieren kann.

In jeder Leuchte eine Galaxie.

Barnaba hat unseren Stil mehr als alle anderen Modelle grundlegend geprägt. Das 1974 entworfene Modell verkörpert drei Eigenschaften, die auch heute noch unverwechselbare Signaturen unserer Marke sind.

Die Verbindung von Glas mit Messing, die „Sand“-Dekoration des Glases und die Ringe.

Diese Skulpturleuchte besteht aus einem Sockel, der die Lichtquelle verbirgt. Von diesem gehen Strahlen aus Metallstäben ab, die unterschiedliche Durchmesser zeichnen. Über der Lichtquelle befindet sich ein kunstvoll von Hand gefertigtes Glas.

Aus handgefertigtem künstlerischem Glas von ca. 7 kg.

**ES.** Barnaba. Una lámpara, una galaxia.

La lámpara de mesa de las colecciones Esperia que puede ser definida, con razón, como una verdadera escultura de luz moderna.

Más que ningún otro modelo, Barnaba ha dejado una marca fundamental en nuestro estilo. Diseñada en 1974, reúne tres características que aún hoy son firmas distintivas de nuestra marca.

La combinación del vidrio con el latón, la decoración "arena" del vidrio y los "anillos".

Esta lámpara-escultura está compuesta por una base, que oculta la fuente luminosa, de la que parte una corona de varillas metálicas curvas que dibujan diversos diámetros. Sobre la fuente de luz se encuentra un vidrio artístico hecho a mano.

Vidrio artístico hecho a mano, de aproximadamente 7 kg.

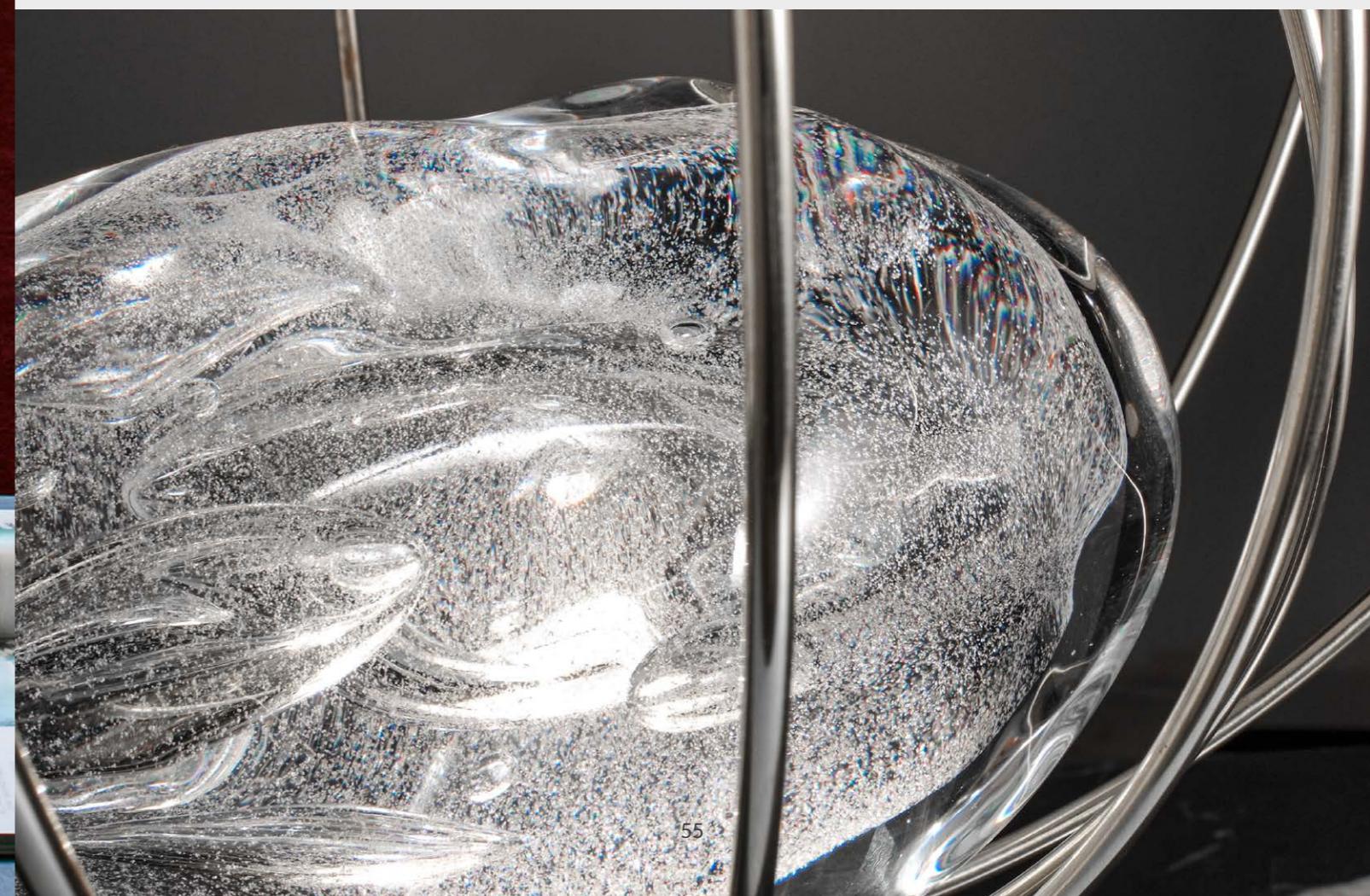



NATALIA  
Design Angelo Brotto, 1976

# NATALIA

Table



# NATALIA

Design Angelo Brotto, 1976

**IT.** La luna di Esperia. Non c'è molto altro da dire. La decorazione pulegosa del vetro ci porta sulla superficie lunare. Al già completo design del pianeta, Brotto aggiunse una conchiglia di fusione artistica di ottone, per esaltare ancora di più l'effetto di luce sul vetro. Natalia è una lampada composta da grande diffusore sferico in vetro lattimo con decorazione pulegosa e fusione artistica di ottone, su base in ottone. Disponibile in versione tavolo, terra e sospensione.

**FR.** La lune d'Esperia. Il n'y a pas grand-chose d'autre à dire. La surface grêlée « pulegosa » du verre évoque la surface de la Lune. Au design déjà complet de cette planète, Brotto ajouta une coquille de laiton moulée de façon artistique, pour exalter encore plus l'effet de lumière sur le verre. La lampe Natalia est composée d'un grand diffuseur sphérique en verre opalin « lattimo » à motif grêlé « pulegosa » et laiton moulé, sur une base en laiton. Disponible en version de table, à pied et suspension.

**DE.** Der Mond von Esperia: weiteres gibt es nicht zu sagen. Die Dekoration des Glases in Pulegoso-Technik schafft die Mondoberfläche. Zu dem bereits fertigen Design des Mondes fügte Brotto eine Hülle aus kunstvollem Messingguss hinzu, um die Wirkung des Lichts auf dem Glas weiter zu verstärken. Die Leuchte Natalia besteht aus einem großen kugelförmigen Diffusor aus Milchglas mit Pulegoso-Dekoration und kunstvollem Messingguss auf einem Messingsockel. Erhältlich in Tisch-, Boden- und Hängeversionen.

## DIMENSION

Glass Diameter: 40 cm / 15,5 In  
Weight: 10 kg

## LIGHT SOURCES

1x E27/26 MAX 25W LED

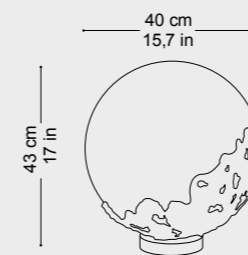

**EN.** Esperia's moon. There is not much more to say. The "pulegoso" decoration of the glass takes us to the surface of the moon. Brotto added an artistic cast brass shell to the already complete design of the planet, to further enhance the effect of light on the glass. Natalia is a lamp with a large, spherical, "lattimo" glass diffuser with "pulegoso" decoration and artistic cast brass, set on a brass base. Available as table, floor and pendant lamp.

**ES.** La luna de Esperia. No hay mucho más para decir. La decoración "pulegosa" (con múltiples pequeñas burbujas) nos transporta a la superficie lunar. Al diseño del planeta, ya completo, Brotto agregó una concha de fundición artística de latón, para resaltar aún más el efecto de luz sobre el vidrio. Natalia es una lámpara compuesta por un gran difusor esférico de vidrio blanco opalescente con decoración "pulegosa" y fundición artística de latón, sobre base de latón. Disponible en versión de mesa, de pie y colgante.

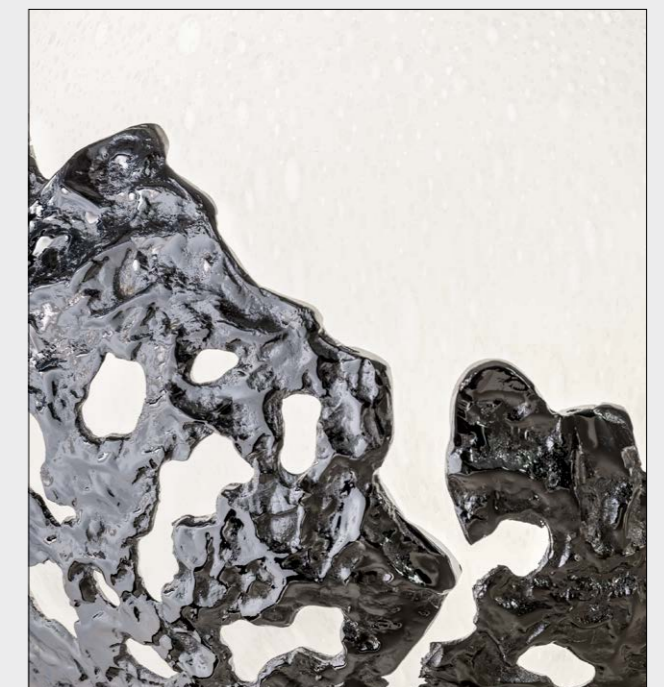

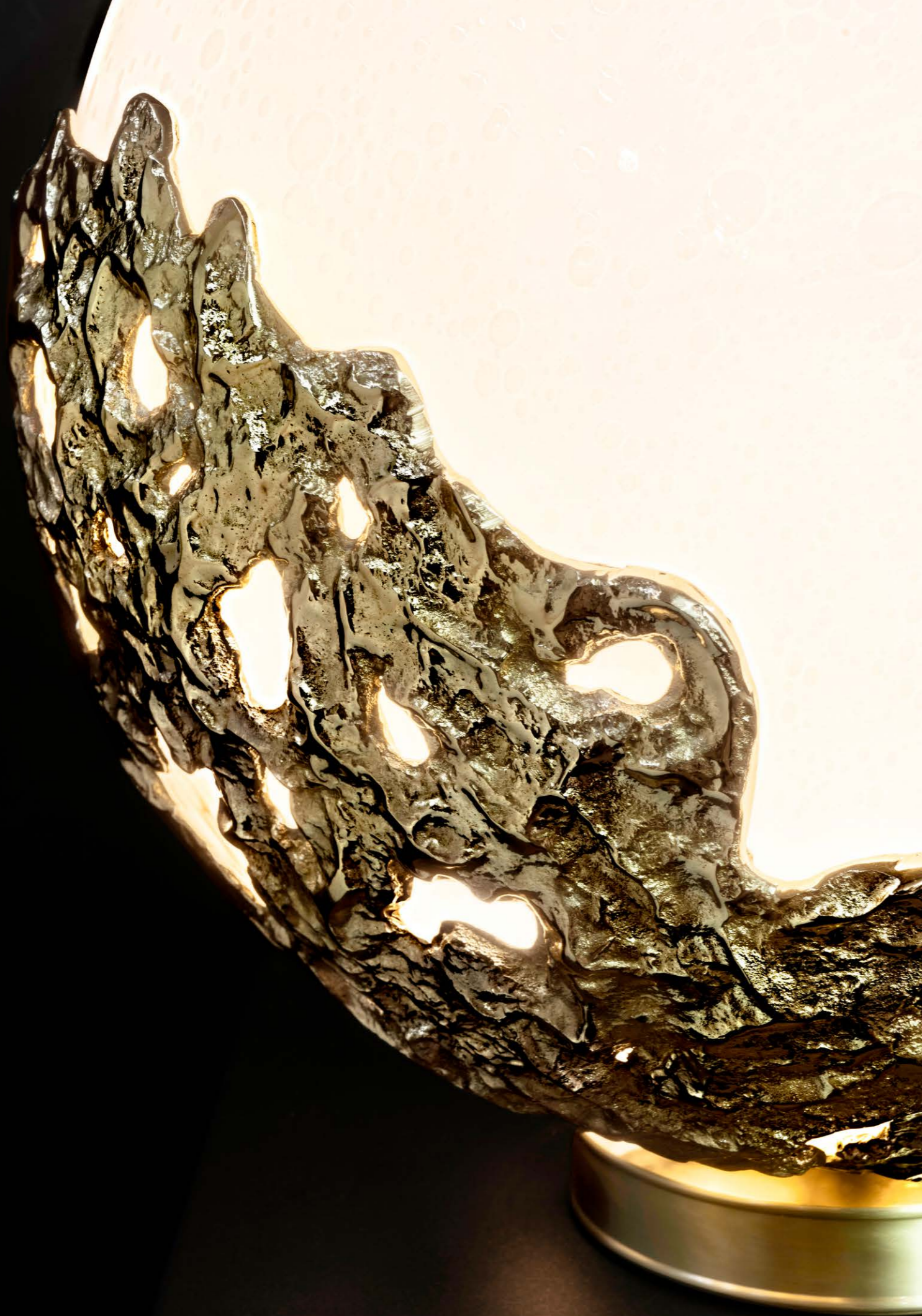

# NATALIA Floor



# NATALIA Floor

## DIMENSION

Height: 175 cm / 69 In  
Glass Diameter: 40 cm / 15,5 In  
Weight: 18 kg

## LIGHT SOURCES

1x E27/26 MAX 25W LED

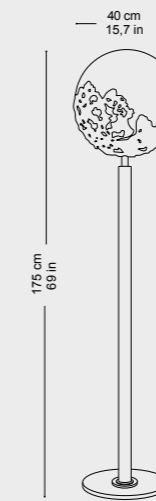

# NATALIA Suspension

## DIMENSION

Height: Customizable  
Glass Diameter: 40 cm / 15,5 In  
Weight: 10 kg

## LIGHT SOURCES

1x E27/26 MAX 25W LED

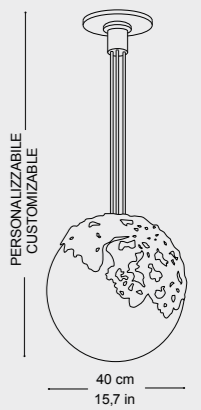



## ASTRID

Design Angelo Brotto, 1969

**IT.** "Una lampada con cui è possibile anche divertisti e giocare". Così Brotto si riferiva a questa lampada. Un piccolo gioiello di cuoio e ottone cromato, che però nasconde in sé l'animo libero dell'artista designer.

**FR.** « Une lampe avec laquelle il est également possible de s'amuser et de jouer ». Ainsi Brotto évoquait cette lampe. Un petit bijou de cuir et laiton chromé, qui dissimule cependant en lui l'esprit libre de l'artiste designer.

**DE.** „Eine Leuchte, mit der man auch Spaß haben und spielen kann". So beschrieb Brotto diesen Entwurf. Ein kleines Schmuckstück aus Leder und verchromtem Messing, das jedoch den freien Geist eines Designers und Künstlers in sich verbirgt.

**EN.** "A lamp you can play and have fun with". This is how Brotto described this lamp. A small jewel made of leather and chromed brass that conceals the free spirit of the designer-artist.

**ES.** "Una lámpara con la que también es posible divertirse y jugar". Así es como Brotto se refería a esta lámpara. Una pequeña joya de cuero y latón cromado, pero que esconde en su interior el espíritu libre del artista diseñador.

### DIMENSION

Height: H 30 cm / 11,8 In

### LIGHT SOURCES

1xG9 Led Max 15W

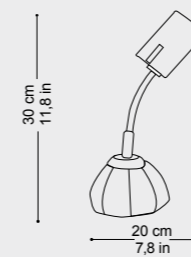

Image from the original catalog

# 02

## MODERN ICONS

UPDATE 2024 — TRASLA  
ERIDANIA  
PANDORA  
UPDATE 2024 — PULSAR  
VEGA  
UPDATE 2024 — COMETA  
SUPERNOVA  
EIRENE  
DAPHNE  
KIT  
DIVA  
LEILA  
DIANA



TRASLA  
Centro Stile Esperia, 2023





# TRASLA

Centro Stile Esperia, 2023

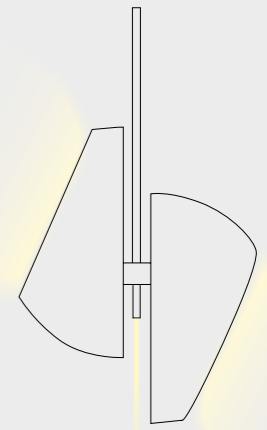
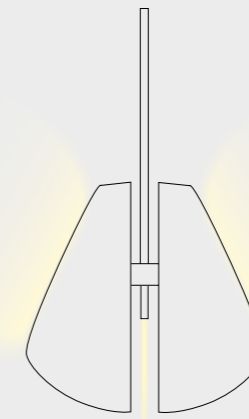
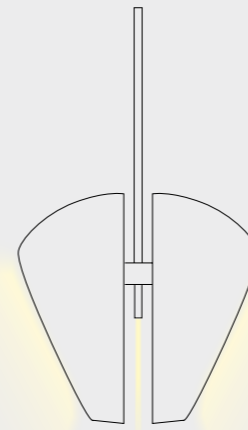

### DIMENSION

35x38 cm H customizable  
45x48 cm H customizable

### LIGHT SOURCES

35x38 cm - 3000K/4000K  
50W-3000 lm-Dimmable  
+ Spot LED 4W

45x48 cm - 3000K/4000K  
60W-4000 lm-Dimmable  
+ Spot LED 4W

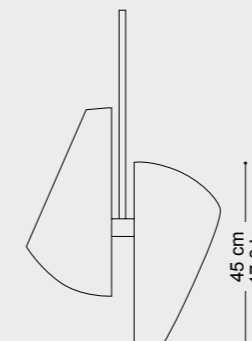
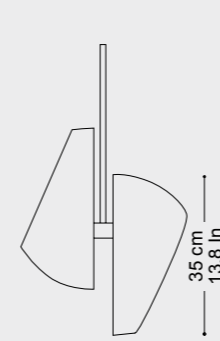





**IT.** La sfera dinamica dalle "infinite configurazioni" di luce.

Movimento, Flessibilità, Tocco.

Attraverso la sua tecnologia, Traslà si muove con una morbidezza unica, garantita dal perfetto bilanciamento interno. E si trasforma continuamente.

"TRASLA ti affascina ogni volta che la tocchi. Quando la muovi, percepisci perfettamente la meccanica bilanciata interna che lavora..."

Traslà è realizzata in acciaio, vetro e plexiglass e può avere fino a 4 fonti luminose indipendenti, dando la possibilità all'utilizzatore di giocare con diversi effetti di luce. Ogni mezzasfera emette luce dal proprio disco frontale e dal disco di chiusura posteriore. È disponibile anche come optional lo spot led con ottica per garantire luce diretta sotto la sospensione.

La versione standard è in bianco opaco, ma è disponibile in ogni colorazione RAL. I componenti interni in ottone e l'asta sono disponibili in tutte le finiture Esperia.

L'obiettivo iniziale del progetto era uscire dalla canonica verticalità della sospensione, "traslando" la posizione dell'asse di illuminamento.

Traslà è flessibilità e tecnica, in quanto raccoglie dentro di sé infinite configurazioni sui propri assi di rotazione che le permettono teoricamente di poter illuminare qualunque punto della stanza.

Il meccanismo interno che permette il movimento è perfettamente bilanciato, garantendo un movimento morbido e preciso.

**EN.** The dynamic globe with "infinite light configurations".

Movement, Flexibility, Touch.

The technology behind Traslà allows for unprecedented smoothness of movement, ensured by the perfect internal balance. And, Traslà changes continually.

"TRASLA enthral you with every touch. Each time you move it, you fully sense the balanced internal mechanics at work..."

Made of steel, glass and Plexiglass, Traslà can have up to 4 independent light sources, giving the user the possibility to play with different light effects.

Each half-globe emits light from its front disc and its rear closing disc. The spotlight with LED optics is available as an option to ensure direct light under the pendant lamp.

The standard version comes in matt white, but all RAL colours are available.

The internal brass components and the stem are available in all Esperia finishes.

The initial objective of the project was to veer from the standard verticality of the pendant light, "translating" the position of the axis of illumination.

Traslà combines flexibility and technique as it allows for infinite configurations on its rotation axes, making it theoretically possible to illuminate any spot in the room.

The internal movement mechanism is perfectly balanced, ensuring smooth and precise motion.



**FR.** La sphère dynamique aux « infinies configurations » de lumière.

Mouvement, Souplesse, Toucher.

Grâce à sa technologie, Traslà bouge avec une douceur exceptionnelle, assurée par un équilibre interne parfait. Et elle se transforme sans cesse.

«TRASLA fascine, chaque fois qu'on la touche. Lorsqu'on la bouge, l'on perçoit parfaitement le mécanisme interne équilibré qui travaille... »

Traslà est composée d'acier, de verre et de plexiglas et peut disposer d'un maximum de 4 sources lumineuses indépendantes, ce qui offre à l'utilisateur la possibilité de jouer avec différents effets lumineux.

Chaque demi-sphère émet de la lumière à partir de son propre disque frontal et de son disque de fermeture arrière. Le spot LED avec optique est aussi disponible en option en vue de fournir un éclairage direct sous la suspension.

La version standard est en blanc mat, mais elle est aussi déclinée dans tous les coloris RAL. Les composants intérieurs en laiton et la tige sont disponibles dans toutes les finitions Esperia.

Au départ, l'objectif du projet était de se détacher de la verticalité canonique de la suspension, en effectuant une « translation » de la position de l'axe d'éclairage.

Traslà est à la fois flexible et technique, car elle réunit en elle d'infinies configurations sur ses axes de rotation qui lui permettent, théoriquement, d'éclairer n'importe quel point de la pièce.

Le mécanisme interne qui permet le mouvement est parfaitement équilibré, ce qui assure un mouvement souple et précis.

**ES.** La esfera dinámica con "infinitas configuraciones" de luz.

Movimiento, Flexibilidad, Toque.

Gracias a su tecnología, Traslà se mueve con una suavidad única, garantizada por un equilibrio interno perfecto. Y se transforma continuamente.

"TRASLA te cautiva cada vez que la tocas. Cuando la mueves, percibes perfectamente la equilibrada mecánica interna que trabaja..."

Traslà está hecha de acero, vidrio y plexiglás y puede tener hasta 4 fuentes luminosas independientes, lo que da la posibilidad al usuario de jugar con diferentes efectos de luz.

Cada semiesfera emite luz desde su propio disco frontal y desde el disco de cierre trasero. Está disponible también como opcional el spot led con óptica para garantizar luz directa debajo de la lámpara en suspensión.

La versión estándar es de color blanco opaco, pero está disponible en cualquier color RAL. Los componentes internos de latón y la varilla están disponibles en todos los acabados de Esperia.

El objetivo inicial del proyecto era salir de la canónica verticalidad de la suspensión, "trasladando" la posición del eje de iluminación.

Traslà es a la vez flexibilidad y técnica, ya que reúne en sí infinitas configuraciones sobre sus propios ejes de rotación, que le permiten en teoría iluminar cualquier punto de la habitación.

El mecanismo interno que permite el movimiento está perfectamente equilibrado, lo que garantiza un movimiento suave y preciso.

**DE.** Die dynamische Kugel mit „unendlichen Konfigurationen“ aus Licht.

Bewegung, Flexibilität, Berührung.

Mit Hilfe ihrer Technologie bewegt sich Traslà einzigartig sanft, garantiert durch die perfekte innere Balance. Und sie verändert sich ständig.

„TRASLA fasziniert jedes Mal, wenn man sie berührt. Bei der Bewegung nimmt man die ausgewogene innere Mechanik perfekt wahr ...“

Traslà besteht aus Stahl, Glas und Plexiglas und kann bis zu vier unabhängige Lichtquellen haben, was dem Benutzer die Möglichkeit gibt, mit verschiedenen Lichteffekten zu spielen.

Jede Halbkugel strahlt Licht von ihrer vorderen Scheibe und ihrer hinteren Abschlusscheibe ab. Optional ist auch ein LED-Spot mit Optik für direktes Licht unter der Aufhängung erhältlich.

Die Standardversion ist in mattem Weiß gehalten, es ist jedoch auch jede RAL-Farbe erhältlich. Die internen Komponenten aus Messing und der Schaft sind in allen Esperia-Oberflächen Ausführungen verfügbar.

Das ursprüngliche Ziel des Projekts bestand darin, die kanonische vertikale Ausrichtung der Aufhängung aufzugeben und die Position der Beleuchtungsachse zu „versetzen“.

Traslà steht für Flexibilität und Technik, da sie auf ihren Rotationsachsen unendlich viele Konfigurationen bietet, die es theoretisch ermöglichen, jeden Punkt des Raumes zu beleuchten.

Der innere Mechanismus ist perfekt ausbalanciert und garantiert eine reibungslose und präzise Bewegung.



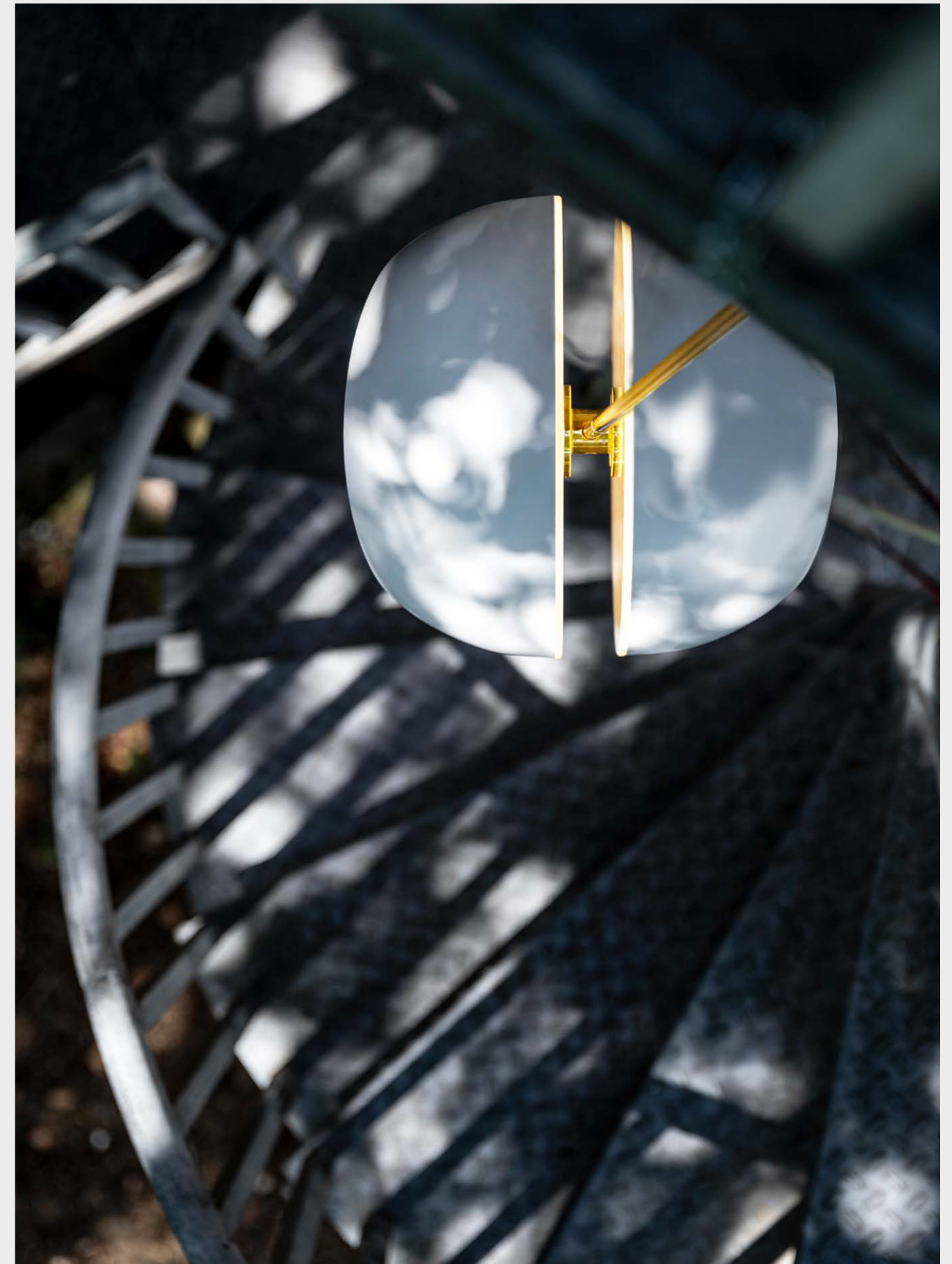



## TRASLA UNICA

**IT.** Trasla è disponibile anche nella versione "Unica". Essa si differenzia per due caratteristiche.

Le mezzesfere sono realizzate in ottone, e sono disponibili nella finitura "Ottone Cromato" o "Ottone Lucido". Inoltre, i dischi frontali emettono luce diretta, e sono schermati da un vetro serigrafato sfumato.

**FR.** Trasla est aussi disponible en version « Unica ». Elle se distingue par deux caractéristiques. Les demi-sphères sont en laiton et disponibles dans les finitions « laiton chromé » ou « laiton poli ». De plus, les disques avant émettent une lumière directe et sont protégés par un verre sérigraphié fumé.

**DE.** Trasla ist auch in der Version „Unica“ erhältlich. Sie unterscheidet sich in zwei Merkmalen. Die Halbkugeln bestehen aus Messing und sind in den Ausführungen „verchromtem Messing“ oder „poliertem Messing“ erhältlich. Darüber hinaus geben die Frontscheiben direktes Licht ab und werden durch ein schattiertes Siebdruckglas abgeschirmt.

Centro Stile Esperia, 2023

**EN.** Trasla is also available in the "Unica" version, which differs by two characteristics.

The half-globes are made of brass, and are available in the "Chromed Brass" or "Polished Brass" finish. Moreover, the front discs emit direct light, and are screened by blurred silk-screen printed glass.

**ES.** Trasla está disponible también en la versión "Unica". La misma se diferencia por dos características. Las semiesferas han sido fabricadas con latón, y están disponibles en los acabados "Latón Cromado" o "Latón Brillante". Además, los discos frontales emiten luz directa y están protegidos por un vidrio serigrafiado esfumado.



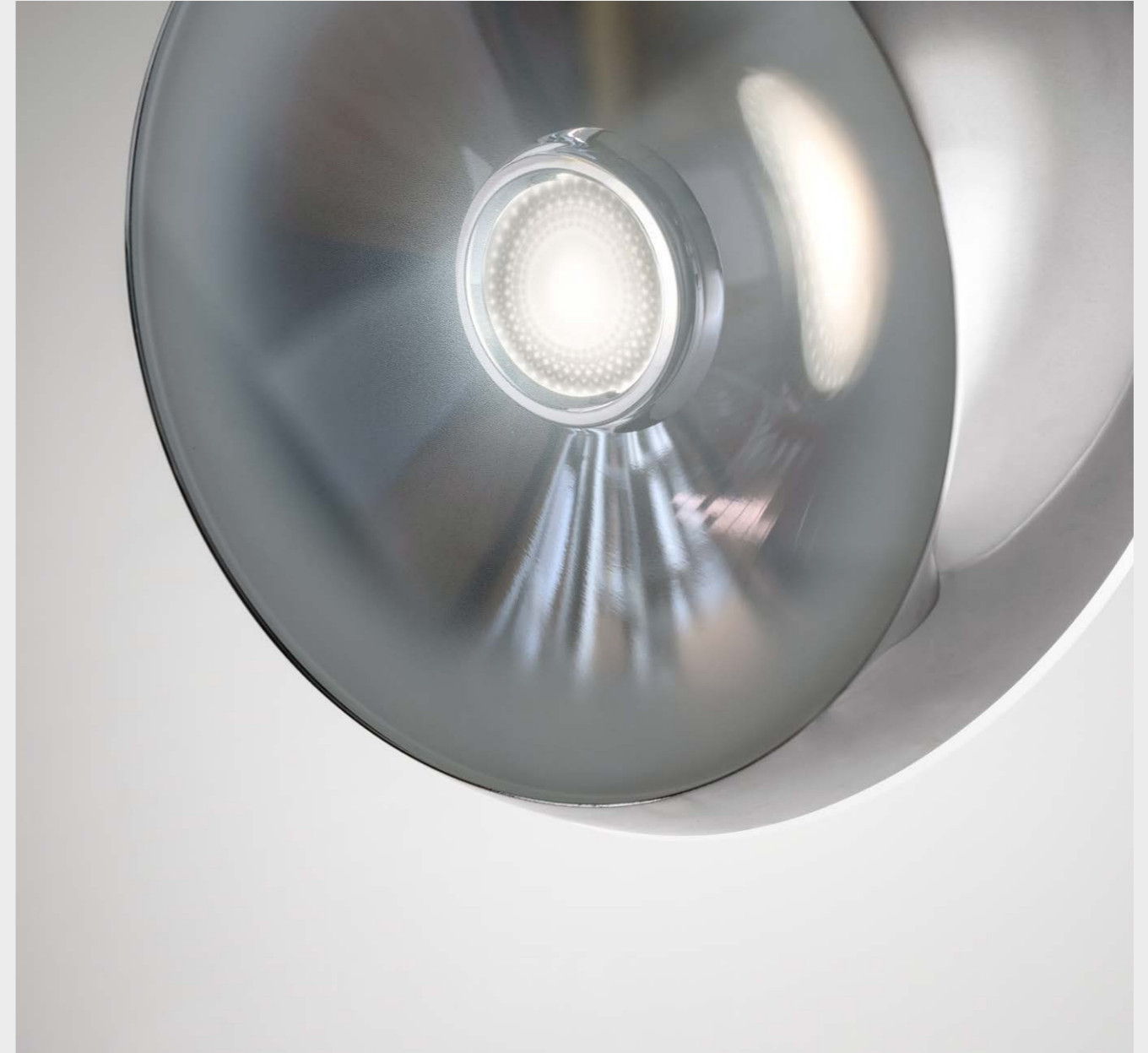



# ERIDANIA

Centro Stile Esperia, 2022



# ERIDANIA

Centro Stile Esperia, 2022

**IT.** Una lampada minimale ma estremamente curata nei dettagli e nei materiali utilizzati, con un forte impatto emozionale. Un "oggetto" illuminante che ridefinisce gli standard di una moderna lampada decorativa di alta gamma. Cuoio (disponibile in versione eco) e ottone. Morbidezza e rigidità. Uomo e macchina. Partendo da una lastra di ottone solido spessa 10mm ( per finiture Gold ) o una lastra in alluminio spessa 12mm ( per finiture Silver ) , i LED sono inseriti all'interno di fresature e coperte da strisce opaline. Nella versione Terra-Soffito, la piastra di ottone sembra letteralmente sospesa e sostenuta fra le due cinture.

**FR.** Une lampe minimaliste mais extrêmement soignée au niveau des détails et des matériaux utilisés, avec un fort impact émotionnel. Un « objet » d'éclairage qui redéfinit les standards d'une moderne lampe décorative haut de gamme. A partir d'une plaque en laiton massif de 10 mm d'épaisseur (pour les finitions dorées) ou d'une plaque en aluminium de 12 mm d'épaisseur (pour les finitions argentées), les LED sont insérées dans des fraisages et couvertes par des bandes opalines. Dans la version Terre-Plafond, la plaque de laiton semble littéralement suspendue et soutenue entre les deux ceintures.

**DE.** Eine minimale Leuchte, jedoch äußerst präzise in den verwendeten Details und Materialien und mit einer starken emotionalen Wirkung. Ein leuchtendes „Objekt“, das die Maßstäbe einer modernen High-End-Dekoleuchte neu definiert. Ausgehend von einer massiven Messingplatte mit einer Dicke von 10 mm für Gold-Finishes oder von einer Aluminiumplatte mit einer Dicke von 12 mm für Silber-Finishes werden die LEDs in Nuten eingesetzt und mit Streifen aus opalem abgedeckt. Bei der Floor-Ceiling-Version scheint die Messingplatte zwischen den beiden Gurten buchstäblich zu schweben.

**EN.** A minimal lamp that nonetheless shows utmost care to detail and the materials used, with a strong emotional impact. An illuminating "object" that redefines the standards of a modern, high-end decorative lamp. Starting from a 10 mm thick solid brass plate ( for Gold finished ) or a 12 mm thick solid aluminum plate ( for Silver finishes ) , the LEDs are set in grooves and covered with opal strips. In the Floor-Ceiling version, the brass plate seems to be literally suspended and supported between the two belts.

**ES.** Una lámpara minimalista, pero con gran atención en los detalles y en los materiales utilizados, con un fuerte impacto emocional. Un "objeto" luminoso que redefine los estándares de una moderna lámpara decorativa de alta gama. A partir de una lamina de latón sólido de 10 mm de sepesor para acabados dorados o una lámina de aluminio de 12 mm de espesor para acabados plateados, los ledes están ubicados en el interior de ranuras fresadas y cubiertos por tiras opalinas. En la versión de pie-de-techo, la placa de latón parece literalmente suspendida y sostenida entre las dos correas.



COL. 001 Black  
COL. 002 Dark Brown  
COL. 003 Light Brown



# ERIDANIA Floor to Ceiling

## DIMENSION

Brass Plate 1 Meter / 39 In  
Height: Customizable  
Weight: 10 kg

## LIGHT SOURCES

Strip LED DC24V - 44W  
Temperature: 3000k Dimmable  
CRI: >90 Lumen: 1900

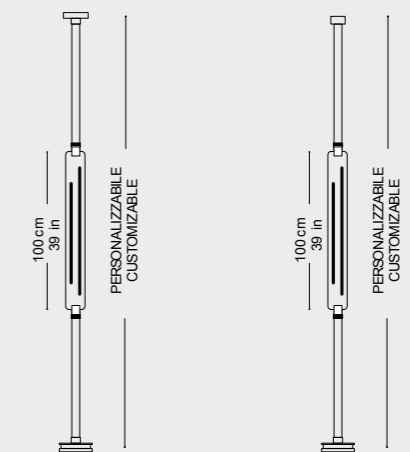

See pag.92



COL. 004



COL. 005



COL. 006



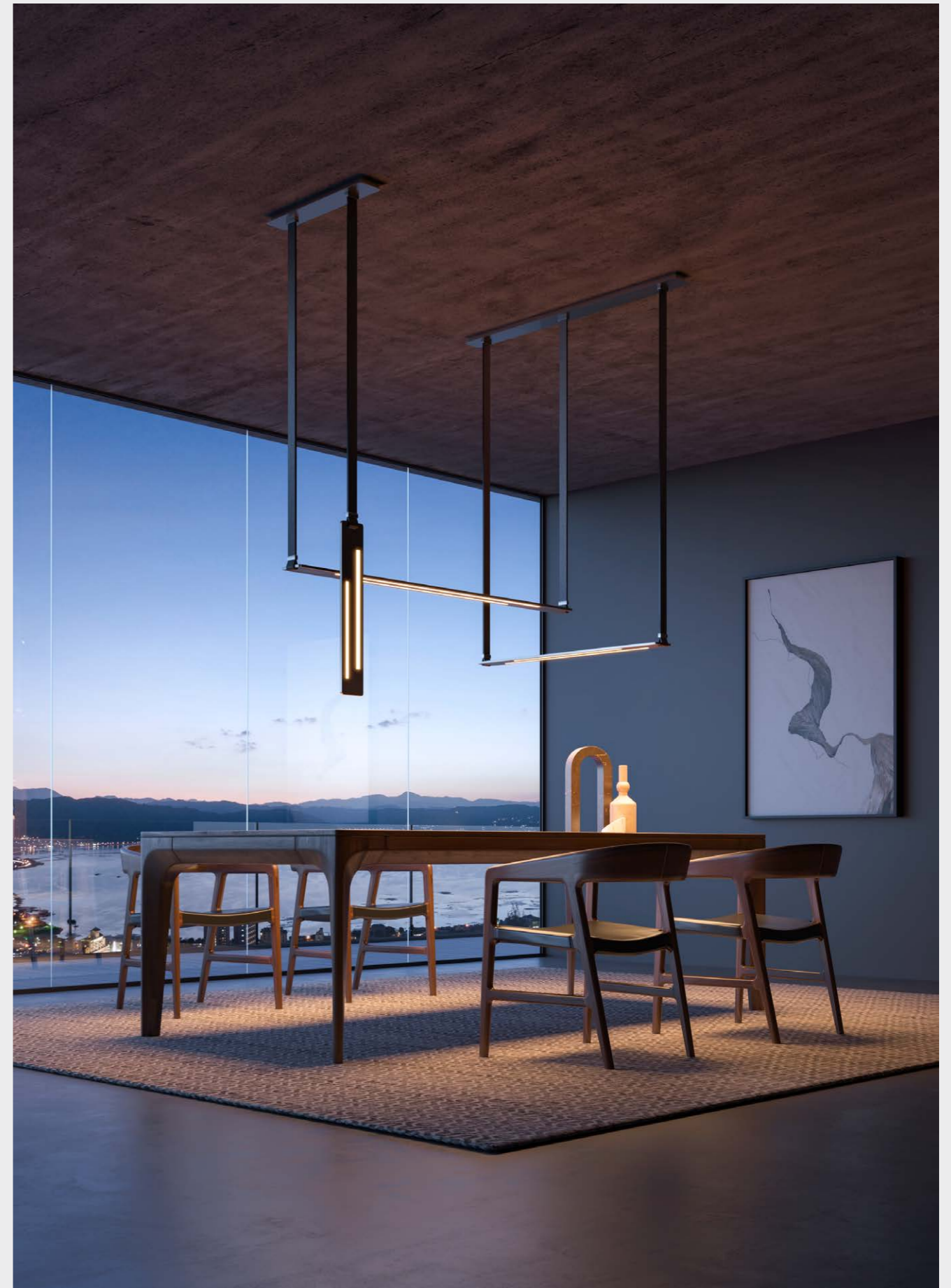



# ERIDANIA

## Chandelier

### 1 M / 39 IN

Weight: 11 kg / 24 lb  
Strip LED DC24V - 45W  
Temperature: 3000k Dimmable  
CRI: >90 Lumen: 2000

### 1,50 M / 60 IN

Weight: 16 kg / 35 lb  
Strip LED DC24V - 70W  
Temperature: 3000k Dimmable  
CRI: >90 Lumen: 2900



### 2 M / 78 IN

Weight: 20 kg / 44 lb  
Strip LED DC24V - 90W  
Temperature: 3000k Dimmable  
CRI: >90 Lumen: 3500

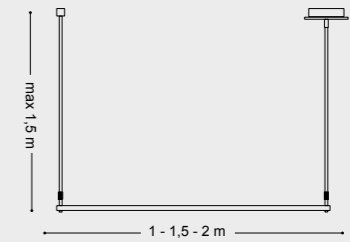
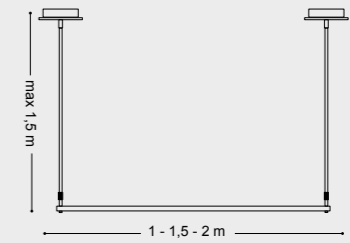

See pag.92







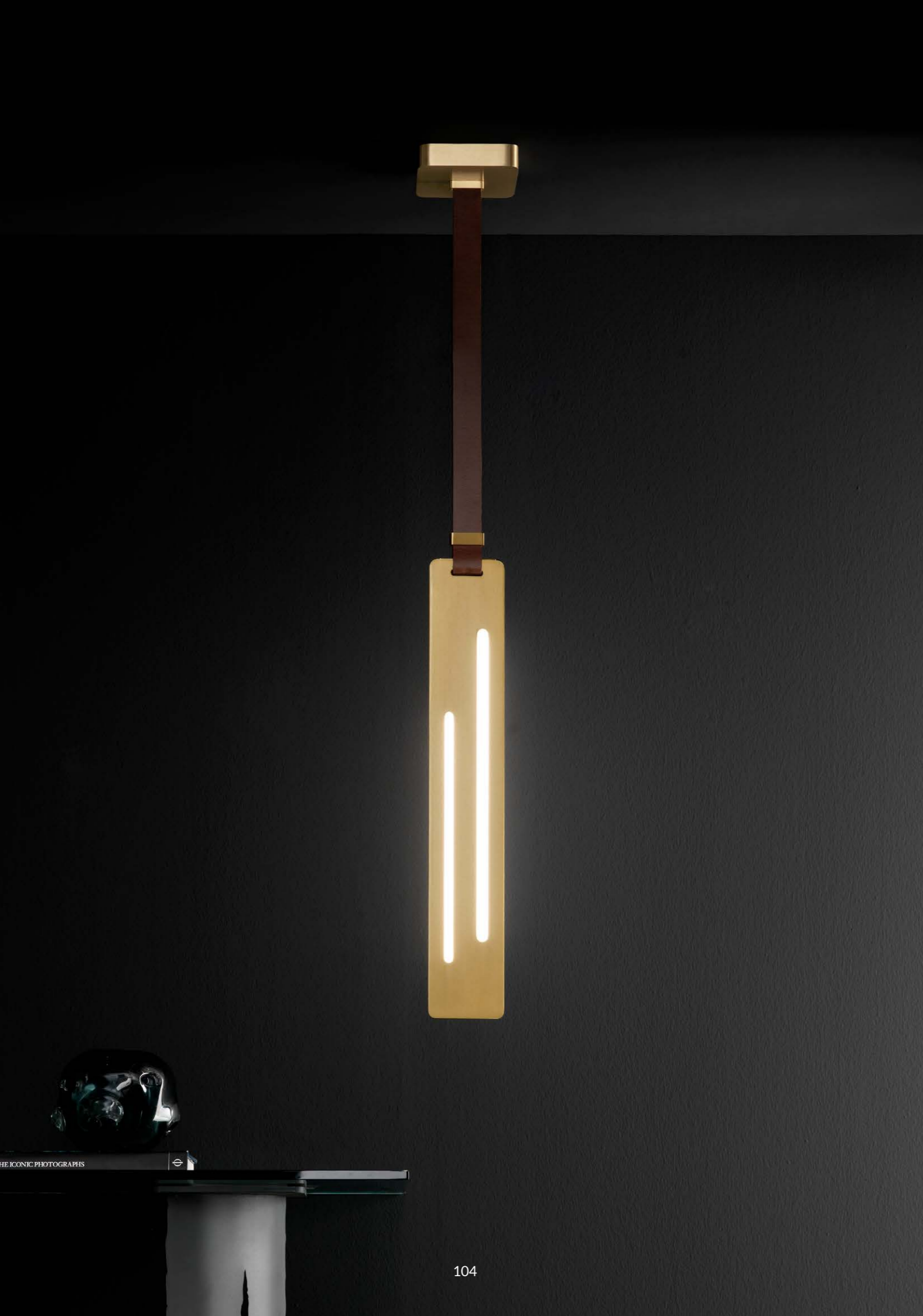

# ERIDANIA Suspension 2

## DIMENSION

Height: 60 cm  
Belt Heigh: 150cm  
Weight: 8 kg

## LIGHT SOURCES

Strip LED DC24V - 25W  
Temperature: 3000k Dimmable  
CRI: >90





PANDORA  
Centro Stile Esperia, 2023



# PANDORA

Centro Stile Esperia, 2023

## IT. Materia, natura, autenticità.

Arrivano direttamente da Volterra, qui in Toscana, tutte le lastre di alabastro che compongono "Pandora". Ognuna di esse è sempre unica e diversa nella forma, nella gradazione di colore e nelle venature sulla pietra. Quattro diametri per dare forma all'oggetto. I bordi di ogni lastra sono al naturale, per sottolineare il collegamento con la pietra "genuina" affinché ogni pezzo sia sempre unico.

La struttura centrale in ottone, sostiene le lastre e completa l'estetica. Dalle lastre di pietra pura esce luce diffusa emessa dalle diverse strip led, che disegnano linee di luce sull'alabastro.

L'ottica in vetro sotto la lastra inferiore garantisce illuminazione diretta sotto il lampadario.

## FR. Matière, nature, authenticité.

L'intégralité des dalles d'albâtre qui constituent « Pandora » provient directement de notre Toscane, précisément de Volterra. Chacune d'entre elles est unique et différente au niveau de sa forme, son dégradé de couleurs et les veines de la pierre.

Quatre diamètres pour donner forme à l'objet. Les bords de chaque dalle sont laissés naturels, en vue d'exalter le lien avec la pierre « authentique » et de garantir l'unicité de chaque pièce.

La structure centrale en laiton soutient les dalles et complète l'esthétique. Des dalles de pierre pure jaillit une lumière diffuse émise par les différentes bandes LED, qui tracent des lignes lumineuses sur l'albâtre.

L'optique en verre sous la dalle inférieure apporte un éclairage direct sous le lustre.

## DE. Materie, Natur, Authentizität.

Alle Alabasterplatten, aus denen „Pandora“ besteht, kommen direkt aus Volterra, hier in der Toskana. Jede Platte ist immer einzigartig und unterscheidet sich in Form, Farbverlauf und Maserung des Steins.

Vier Durchmesser, um dem Objekt Form zu geben. Die Kanten jeder Platte sind naturbelassen, um die Verbindung mit dem „echten“ Stein zu betonen. Somit ist jedes Stück immer ein Unikat.

Die zentrale Struktur aus Messing trägt die Platten und vervollständigt die Ästhetik. Aus den Platten aus reinem Stein strömt diffuses Licht, das von den verschiedenen LED-Streifen abgegeben wird und Lichtlinien auf den Alabaster zeichnet.

Die Glasoptik unter der unteren Platte garantiert die direkte Beleuchtung des Bereichs unter der Leuchte.

## EN. Substance, nature, authenticity.

All the alabaster slabs that make up "Pandora" come directly from Volterra, here in Tuscany. Each one is always unique and differs in shape, shade and veins on the stone.

Four diameters give shape to the object. The edges of each slab keep their natural finish, enhancing the connection with the "genuine" stone, and making each piece exclusive.

The central brass structure supports the slabs and complements the design. The various LED strips draw bright lines on the alabaster and emit diffused light from the pure stone slabs.

The glass optics under the lower slab ensure direct lighting under the chandelier.

## ES. Materia, naturaleza, autenticidad.

Todas las placas de alabastro que componen "Pandora" proceden directamente de Volterra, aquí en la Toscana. Cada una de ellas es única y diferente en términos de forma, gradación de color y veteado de la piedra.

Cuatro diámetros dan forma al objeto. Los bordes de cada placa son naturales, para enfatizar la conexión con la piedra "genuina" y así garantizar que cada pieza sea siempre única.

La estructura central de latón sostiene las placas y completa la estética. De las placas de piedra pura sale una luz difusa emitida por las diferentes tiras de LED, que dibujan líneas de luz sobre el alabastro.

La óptica de vidrio situada bajo la placa inferior garantiza una iluminación directa bajo la lámpara de araña.

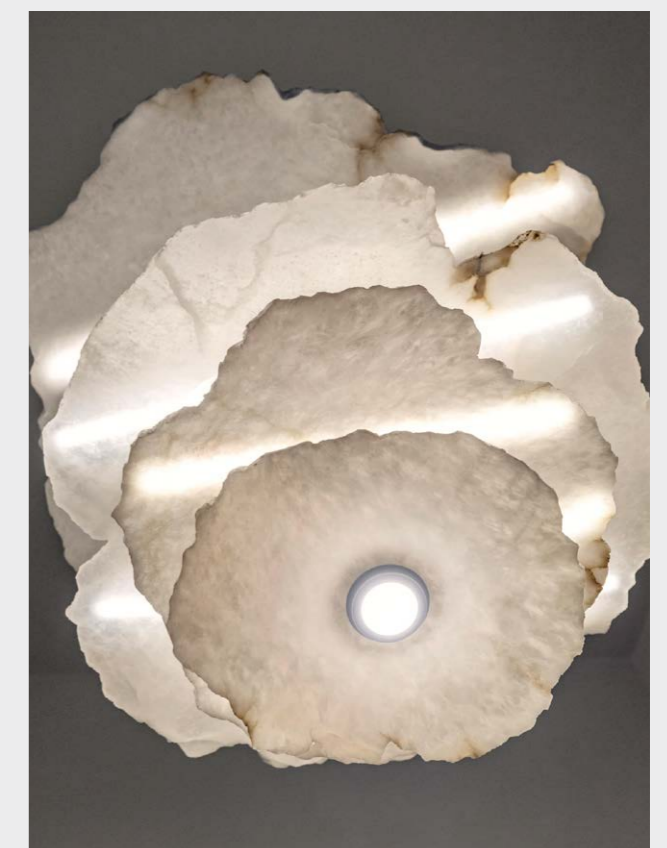

## DIMENSION

Central Body  
85x60 cm

## LIGHT SOURCES

LED 60W - 3000k - 3500 lm

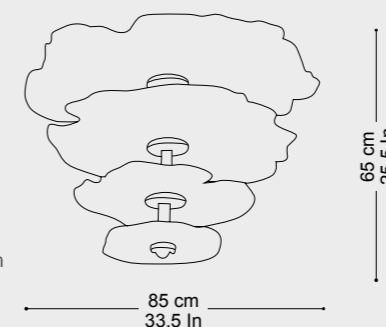





## PULSAR

Design Cristina Celestino, 2019

"L'ispirazione viene da uno sguardo disincantato verso quel cielo a cui guardava Brotto negli anni '60: Pulsar si ispira ai segni grafici delle rappresentazioni delle stelle pulsar..."

—— "The inspiration comes from a disenchanted glance towards the same sky that Brotto gazed at back in the 1960s: Pulsar is inspired by the graphic signs that represent pulsar stars..."

# PULSAR Single



# PULSAR

Design Cristina Celestino, 2019

**IT. Pulsar Singolo:** Lampada a sospensione composta da tre anelli in ottone con fonte luminosa inserita all'interno di un volume di vetro cavo con decorazione sabbia, finitura ottone satinato.

**Pulsar Completo:** Lampada a sospensione composta da trenta anelli in ottone con fonti luminose inserite all'interno dei 4 vetri per una luce diffusa e nel corpo centrale per un fascio di luce diretta sotto il lampadario.

**FR. Pulsar Simple:** suspension composée de trois anneaux en laiton avec source lumineuse insérée au sein d'un volume en verre creux avec motif sablé, finition laiton satiné.

**Pulsar Complet:** suspension composée de trente anneaux en laiton avec des sources lumineuses insérées au sein de 4 verres, pour une lumière diffuse, et dans le corps central pour un faisceau de lumière directe sous le lustre.

**DE. Pulsar einzeln:** Pendelleuchte aus drei Messingringen mit Lichtquelle, die in ein Volumen aus Hohlglas mit Sanddekor eingesetzt ist; satiniertes Messing-Finish.

**Pulsar komplett:** Pendelleuchte aus dreißig Messingringen mit Lichtquellen, die in den vier Gläsern für ein diffuses Licht und im zentralen Körper für einen direkten Lichtstrahl unter der Leuchte eingesetzt sind.

**EN. Pulsar Single:** Pendant lamp with three brass rings and light source inserted inside a hollow glass globe with sanded decoration; satin brass finish.

**Pulsar Complete:** Pendant lamp composed of thirty brass rings with light sources inserted inside the four glass globes, for a diffused light, and in the central part of the structure for a direct light beam under the chandelier.

**ES. Pulsar Único:** Lámpara colgante compuesta por tres anillos de latón con fuente luminosa introducida dentro de un volumen de vidrio hueco con decoración de arena y acabado de latón satinado.

**Pulsar Completo:** Lámpara colgante compuesta por treinta anillos de latón con fuentes luminosas introducidas en el interior de los 4 vidrios, para una luz difusa, y, en el cuerpo central, para un haz de luz directa debajo de la lámpara.

## Pulsar Single

### DIMENSION

Height: Customizable  
Ring Diameter: 36 cm / 14 In  
Weight: 3 kg

### LIGHT SOURCES

1x G9 Led Max: 12W

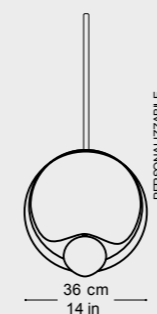

## Pulsar Complete

### DIMENSION

Total Height: Customizable  
Central Body Diameter: 82cm / 32 In  
Weight: 22 kg

### LIGHT SOURCES

4x G9 Led Max: 12W + 1x GU10 Led max 7W

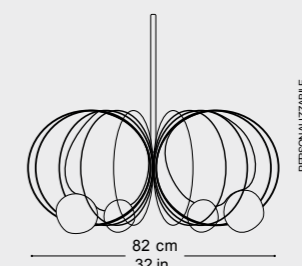



# PULSAR Mini

## DIMENSION

Height: Customizable  
Ring Diameter: 20 cm / 7,8 In  
Weight: 2 kg

## LIGHT SOURCES

1x G4 Led Max: 3W

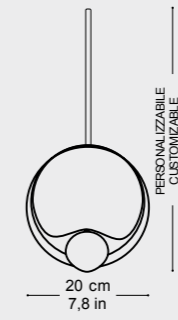





VEGA  
Centro Stile Esperia, 2023



# VEGA

Centro Stile Esperia, 2023

**IT.** Vega nacque come un espositore da tavolo illuminante per gioielli. Affascinati dal suo design, inserimmo nella versione da tavolo, un vetro artistico. Così nacque Vega Tavolo, la prima versione della collezione. Il vetro realizzato a mano del peso di circa 5kg, illuminato dall'alto, si accendeva appunto come un gioiello. Tutte le altre versioni di Vega, sono nate semplicemente e naturalmente come un'evoluzione dell'ispirazione originale. Disponibile in varie finiture. La lampada da tavolo, l'espositore originale, è disponibile con o senza il vetro sulla base.

**FR.** Vega est né comme présentoir de table éclairé pour bijoux. Fascinés par son design, nous avons ajouté dans la version de table un verre artistique. Ainsi a vu le jour Vega Tavolo, la première version de la collection. Réalisé à la main, le verre pèse environ 5 kg et, avec son éclairage par le haut, il s'allumait comme un bijou. Toutes les autres versions de Vega sont nées simplement et naturellement comme une évolution de l'inspiration originale. Disponible en différentes finitions. La lampe de table, le présentoir original, est disponible avec ou sans verre sur la base.

**DE.** Vega entstand zunächst als leuchtendes Tischdisplay für Schmuck. Fasziniert vom Design haben wir bei der Tischversion ein kunstvolles Glas eingesetzt. So entstand Vega Tavolo, die erste Version der Kollektion. Das handgefertigte, von oben beleuchtete Glas mit einem Gewicht von ca. 5 kg erschien wie ein Juwel. Alle anderen Versionen von Vega entstanden einfach und natürlich als Weiterentwicklung der ursprünglichen Inspiration. Erhältlich in verschiedenen Ausführungen. Die Tischleuchte, das originelle Display, ist mit oder ohne Glas am Fuß erhältlich.

**EN.** Vega was conceived as a lit, tabletop display case for jewellery. Fascinated by its design, we added an artistic glass element in the table version. This led to the creation of Vega Tavolo, the first version of the collection. The handmade glass element weighing about 5 kg, lit from above, shined just like a jewel. All other versions of Vega are the simple and natural evolution of the original inspiration. Available in various finishes. The table lamp, the original display case, is available with or without glass on the base.

**ES.** Vega surgió como un expositor de mesa luminoso para joyas. Fascinados por su diseño, incorporamos un vidrio artístico a la versión de mesa. Así nació Vega Tavolo, la primera versión de la colección. El vidrio hecho a mano, con un peso de unos 5 kg, iluminado desde arriba, se encendía precisamente como una joya. Todas las demás versiones de Vega surgieron simple y naturalmente como una evolución de la inspiración original. Disponible en variados acabados. La lámpara de mesa, el expositor original, está disponible con o sin el vidrio sobre la base.

## DIMENSION

Central Body  
35x16x17cm / 13,75x6,25x6,75 In

## LIGHT SOURCES

LED 25W - 3000k/4000k - CRI>90

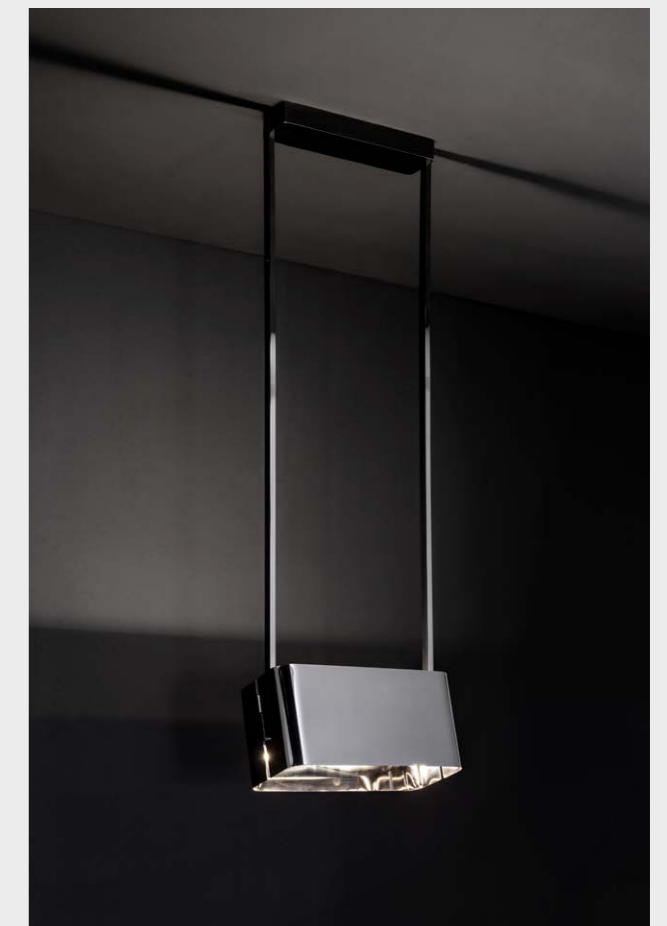
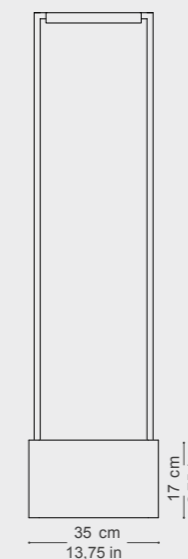





# VEGA Mini

## DIMENSION

Central Body  
20x11x15cm / 7,9x4,3x5,9

## LIGHT SOURCES

LED 16W - 3000k/4000k - CRI>90

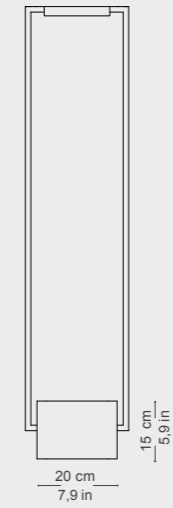



# VEGA Large

## DIMENSION

Central Body  
138x15x15cm / 54,5x5,9x5,9 in

## LIGHT SOURCES

LED 70W - 3000k/4000k - CRI>90

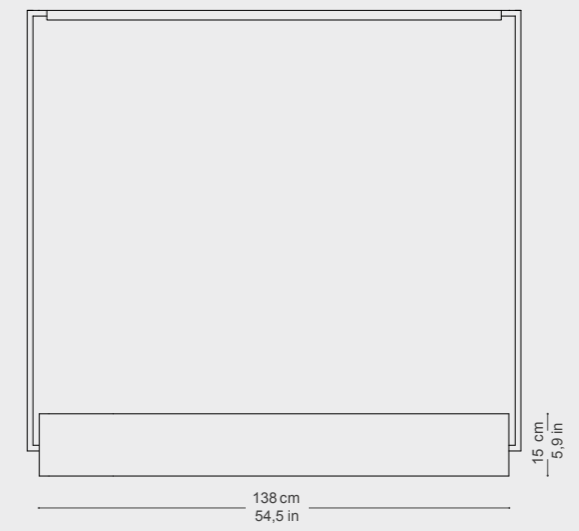







# VEGA Table

## DIMENSION

Height: H 50 cm / 19.7 In  
Central Body  
20x11x15cm / 7,9x4,3x5,9

## LIGHT SOURCES

1x E27/E26 Led Max: 25W

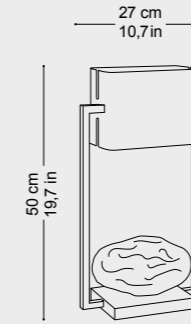



# VEGA Floor

## DIMENSION

Total Height: 150cm / 59 In  
Weight: 18 Kg

## LIGHT SOURCES

1x E27/E26 Led Max: 25W

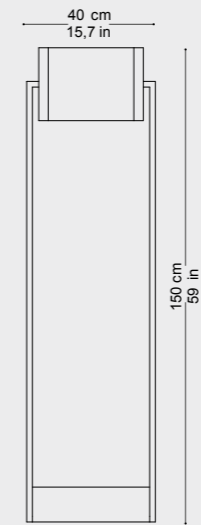



## VEGA Wall

### DIMENSION

20x11x15cm / 7,9x4,3x5,9

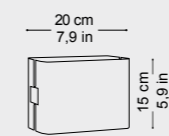

### LIGHT SOURCES

1x E27/E26 Led Max: 25W

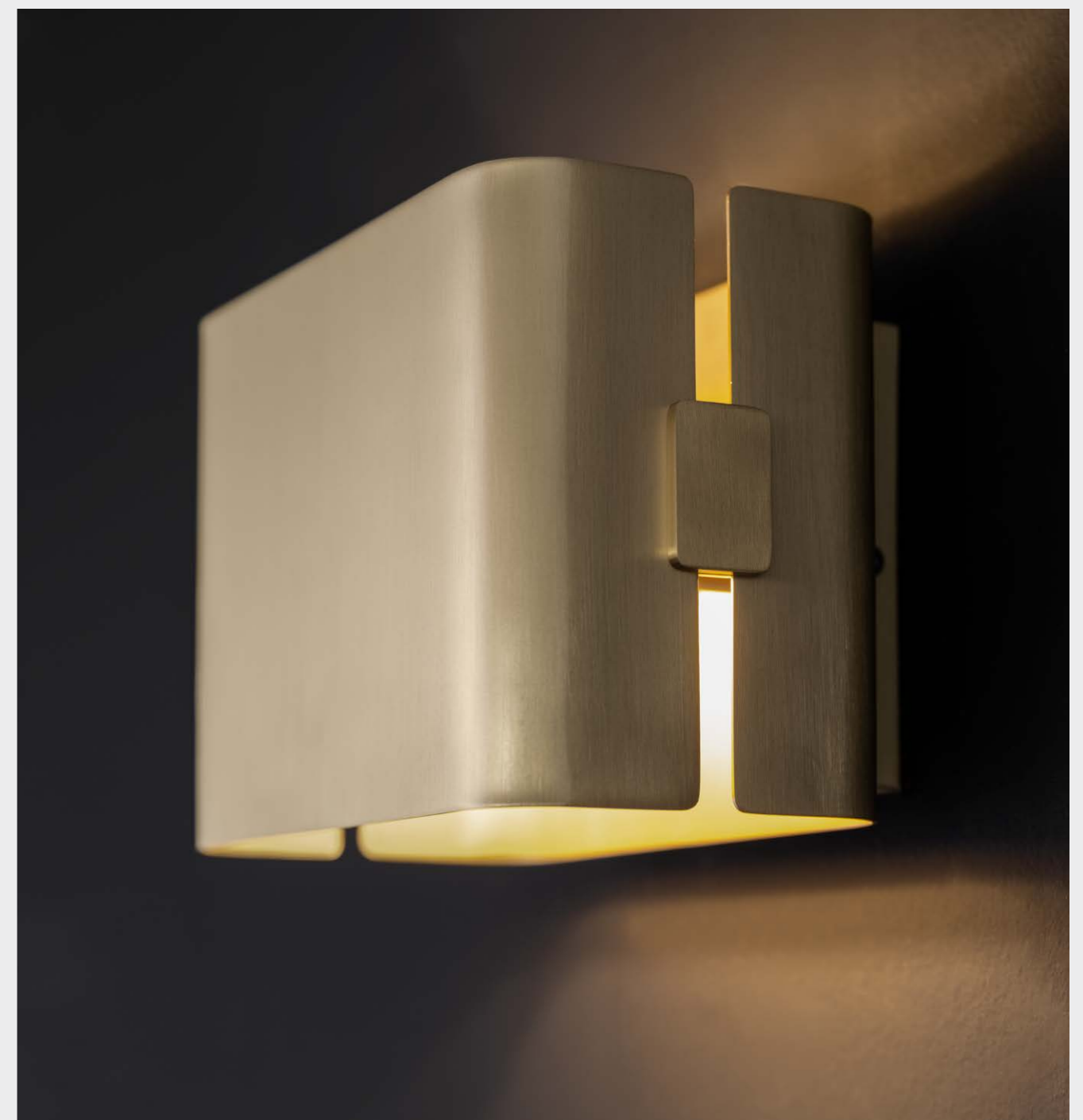



# COMETA

Centro Stile Esperia, 2024



# COMETA

Centro Stile Esperia, 2024

**IT.** Lampadario realizzato con struttura in ottone. Raffinate e moderne catene in ottone sorreggono cristalli realizzati a mano che riflettono la luce emessa da altrettanti corpi illuminanti di forma cilindrica o con finale a campanula. Il diametro, l'altezza totale, il numero e la disposizione dei cristalli e dei punti luce è personalizzabile.

**EN.** Chandelier with brass structure. Refined and modern brass chains of different heights support handmade crystals that reflect the light of brass cylindrical or bellflower light diffusers. The diameter, total height, number and configuration of crystals and light points are customizable.

**FR.** Lustre réalisé avec une structure en laiton. Des chaînes en laiton raffinées et modernes soutiennent des cristaux/verres faits à la main, qui réfléchissent la lumière émise par autant des corps lumineux, de forme cylindrique ou terminés par une cloche. Le diamètre, la hauteur totale, le nombre et la disposition des cristaux/verres et des points lumineux sont personnalisables.

**ES.** Candelabro realizado con estructura de latón. Cadenas refinadas y modernas de latón sostienen cristales/vidrios hechos a mano, que reflejan la luz emitida por igual número de cuerpos iluminantes, de forma cilíndrica o con terminación a campana. El diámetro, la altura total, el número y disposición de los cristales/vidrios y punto luz son personalizables.

**DE.** Chandelier aus Messingstruktur gefertigt. Feine und moderne Messingketten tragen handgefertigte Kristalle/Gläser, das Licht von vielen Zylinder- oder Glockenförmigen Leuchten reflektieren. Durchmesser, Gesamthöhe, Anzahl und Anordnung der Kristalle/Gläser und Lichtpunkte sind anpassbar.

## DIMENSION

Ceiling Canopy Options:  
45cm (17,7 in) - 75cm (29 in) - 105cm (41 in)

## LIGHT SOURCES

Cylindrical diffuser - LED 3W 3000k  
Bellflower diffuser - 1x GU10 LED MAX 5.5W

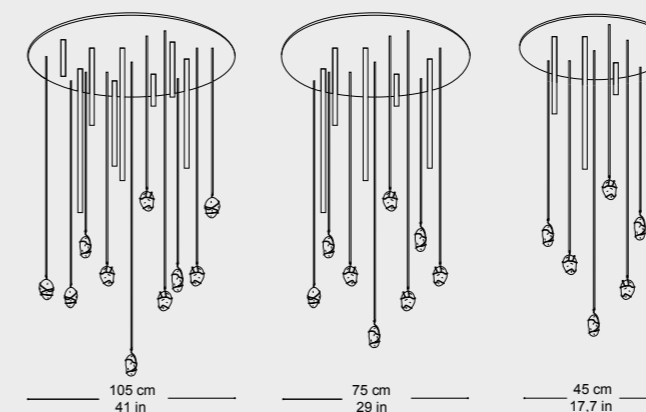

Same canopy/configuration options with bellflower light diffusers.





## SUPERNOVA

Centro Stile Esperia, 2015

Una supernova è un'esplosione stellare più energetica di quella di una nova. Le supernove sono molto luminose e causano una emissione di luce che può per brevi periodi superare quella di una intera galassia.

— A supernova is a powerful explosion of a star, and is more energetic than a nova. Supernovae are very bright and for short periods their luminosity can exceed that of an entire galaxy.



# SUPERNOVA

Centro Stile Esperia, 2015

**IT.** Ogni volta che Supernova si accende, è come una vera e propria esplosione stellare. Supernova è una lampada con corpo in ottone. Il particolare in vetro realizzato a mano, quasi sospeso, schermo e diffonde la luce che proviene dalla fonte luminosa all'interno del cilindro in ottone. Disponibile anche nella nuova versione a parete.

**FR.** Chaque fois que Supernova s'allume, l'on assiste à une véritable explosion étoilée. Le verre suspendu, en s'éclairant, diffuse la lumière sous lui. La lampe Supernova présente un corps en laiton. Le détail en verre réalisé à la main, presque suspendu, protège et diffuse la lumière qui provient de la source lumineuse à l'intérieur du cylindre en laiton. Disponible aussi dans la nouvelle version murale.

**DE.** Bei jedem Aufleuchten von Supernova sieht man eine echte Sternexplosion. Das aufgehängte Glas streut das Licht nach unten. Supernova ist eine Leuchte mit Messingkörper. Das handgefertigte Glas, fast schwebend, schirmt und streut das Licht, das von der Lichtquelle im Inneren des Messingzylinders kommt. Auch in der neuen Wandversion erhältlich.

**EN.** Every time Supernova lights up, it's like a real stellar explosion. The suspended glass element is illuminated and diffuses the light downwards. Supernova is a lamp with a brass structure. The handmade glass detail is almost suspended, and screens and diffuses the light that comes from the light source inside the brass cylinder. Also available in the new wall version.

**ES.** Cada vez que Supernova se enciende, es como una verdadera explosión estelar. El vidrio suspendido, al iluminarse, difunde la luz por debajo. Supernova es una lámpara con cuerpo de latón. El detalle de vidrio hecho a mano, casi suspendido, escuda y difunde la luz que proviene de la fuente luminosa en el interior del cilindro de latón. Disponible también en la nueva versión de pared.

## DIMENSION

Total Height: Customizable  
 Central Body + Crystal: 40 cm / 16 In  
 Weight: 5 kg / 11 lb

## LIGHT SOURCES

1x E27 Par30S Spot Led Max: 20W

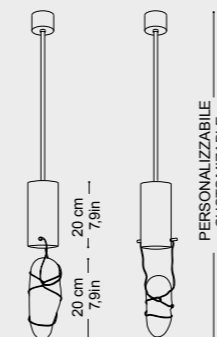







# SUPERNOVA Wall

## DIMENSION

Central Body + Crystal: 40 cm / 16 In  
Weight: 5 kg / 11 lb

## LIGHT SOURCES

1x E27 Par30S Spot Led Max: 20W

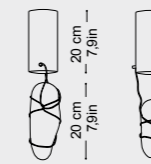



EIRENE  
Centro Stile Esperia, 2020

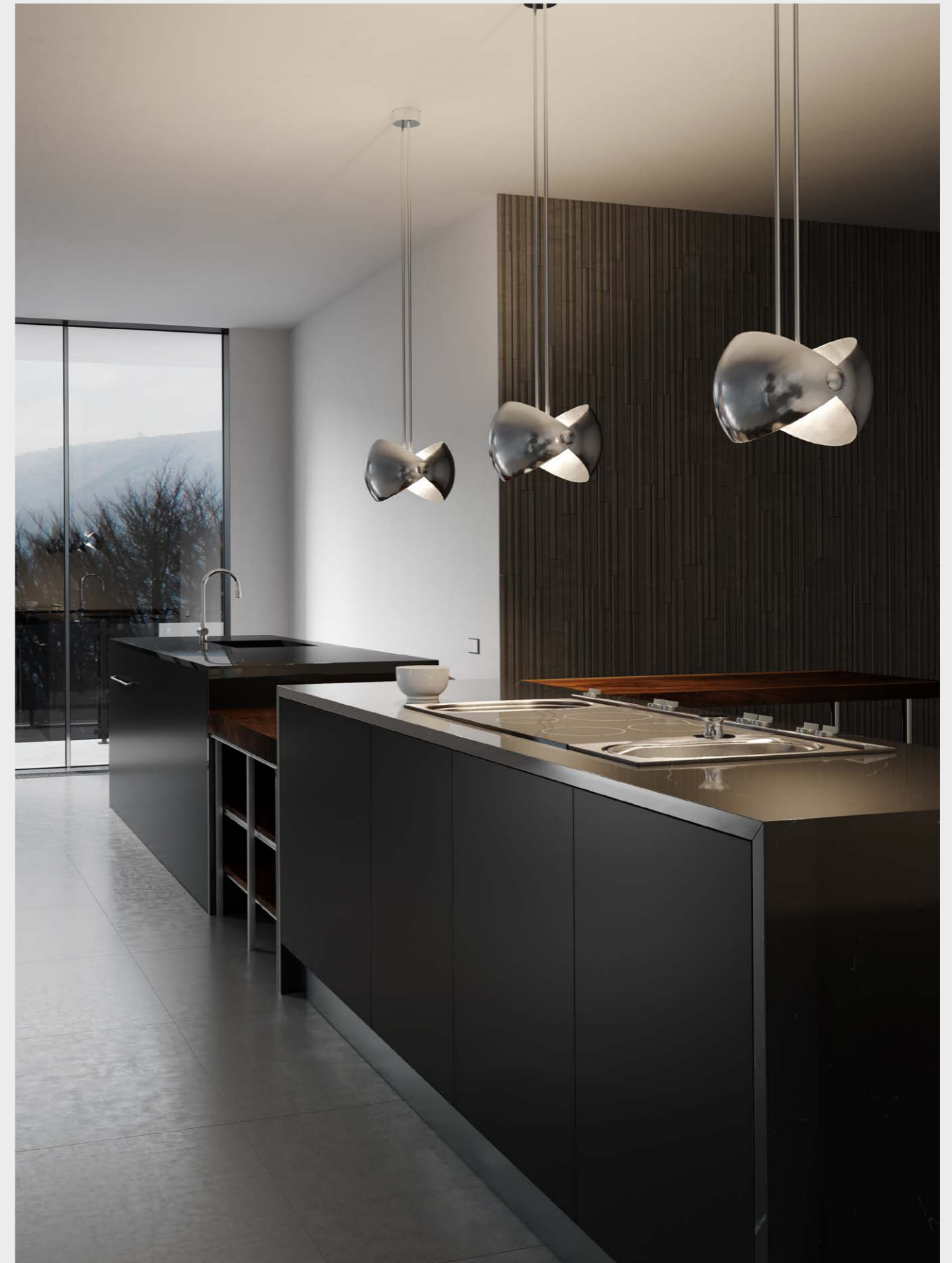

# EIRENE

Suspension



# EIRENE

Centro Stile Esperia, 2020

**IT.** “Eirene” è una delle lampade “dinamiche” più importanti dell’era moderna di Esperia.

Racchiude infatti tutto l’ingegno, la perspicacia e l’esperienza dei progettisti e tecnici del “Centro Stile Esperia”. Eirene è una lampada composta da due quarti di sfera in ottone regolabili in diverse configurazioni per ottenere diverse tipologie di illuminazione. Le due fasce di ottone possono essere realizzate anche in due finiture diverse.

La versione tavolo è disponibile in due versioni: regolabile e non regolabile in altezza. Il movimento è controllato da un meccanismo completamente in ottone progettato e realizzato interamente da Esperia. Sulla versione “Chandelier”, l’altezza può essere regolata su 3 livelli grazie alle aste telescopiche.

**EN.** “Eirene” is one of the most important “dynamic” lamps of Esperia’s modern era.

Indeed, it holds all the ingenuity, perspicacity and experience of the designers and technicians of “Centro Stile Esperia”.

Eirene is a lamp featuring two quarter-spheres made of brass that can be arranged in different configurations to obtain different types of lighting. The two brass bands can also be selected in two different finishes.

The table lamp is available in two versions: with adjustable and non-adjustable height.

The movement is controlled by a mechanism entirely made of brass, designed and manufactured by Esperia. The height of the “Chandelier” version can be adjusted on 3 levels thanks to the telescopic rods.

## Eirene Suspension

### DIMENSION

Total Height: Customizable  
Central body diameter: 32cm / 12,5 In  
Weight: 3 kg

### LIGHT SOURCES

2x GU10 Spot Led Max: 10W



## Eirene Wall

### DIMENSION

Central body diameter: 23cm / 9 In  
Weight: 1 kg

### LIGHT SOURCES

1x E27/E26 Led Max: 15W

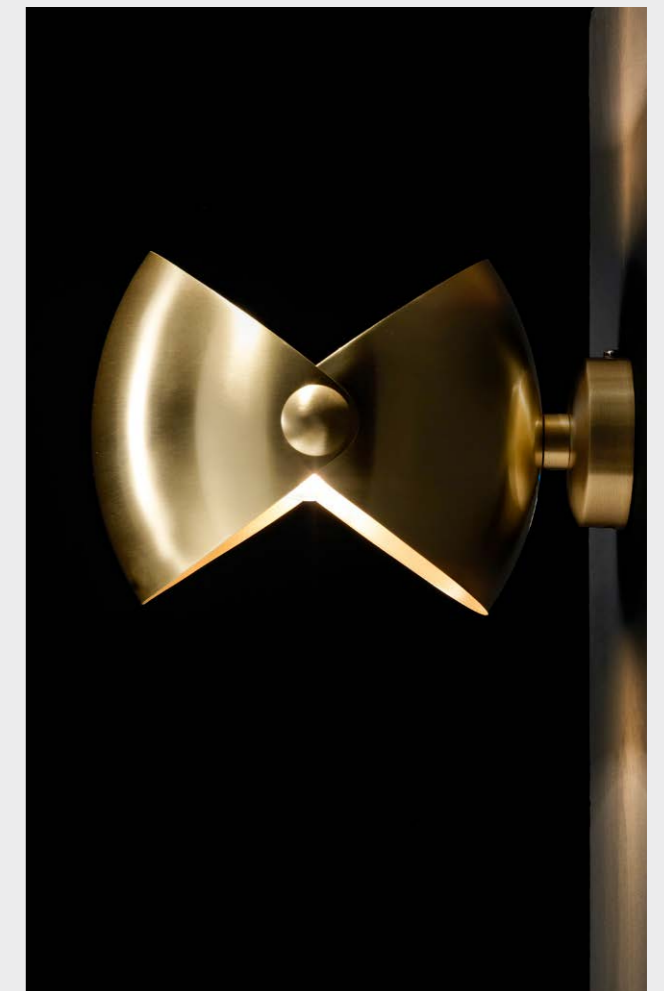
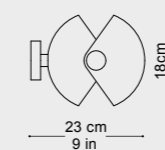

# EIRENE Chandelier



FR. « Eirene » est l'une des plus importantes lampes « dynamiques » de l'ère moderne d'Esperia. Elle rassemble en effet tout le génie, la perspicacité et l'expérience des designers et des techniciens du « Centro Stile Esperia ».

Eirene est une lampe composée de deux quarts de sphère en laiton réglables en différentes configurations pour obtenir différents types d'éclairage. Les deux bandes en laiton peuvent aussi être réalisées en deux différentes finitions.

La version de table est disponible en deux versions : réglable et non réglable en hauteur.

Le mouvement est contrôlé par un mécanisme intégralement en laiton, entièrement conçu et réalisé par Esperia.

Dans la version « Chandelier », la hauteur peut être réglée sur 3 niveaux grâce à des tiges télescopiques.

ES. "Eirene" es una de las lámparas "dinámicas" más importantes de la era moderna de Esperia.

En efecto, reúne todo el ingenio, la perspicacia y la experiencia de los diseñadores y técnicos del "Centro Stile Esperia". Eirene es una lámpara compuesta por dos cuartos de esfera de latón regulables en diferentes configuraciones para obtener diferentes tipos de iluminación. Las dos bandas de latón pueden ser realizadas también con dos acabados diferentes.

La versión de mesa está disponible en dos versiones: regulable y no regulable en altura.

El movimiento es controlado por un mecanismo completamente de latón, diseñado y elaborado en su totalidad por Esperia.

En la versión "Chandelier", la altura puede regularse en tres niveles, gracias a las varillas telescópicas.

DE. „Eirene“ ist eine der wichtigsten „dynamischen“ Leuchten von Esperia aus den modernen Kollektionen.

Sie enthält den ganzen Einfallsreichtum und die Erfahrung der Designer und Techniker des „Centro Stile Esperia“.

Eirene ist eine Leuchte, die aus zwei Viertelkugeln aus Messing besteht, die in verschiedenen Konfigurationen eingestellt werden können. So werden unterschiedliche Beleuchtungsarten erhalten. Die beiden Messingbänder können auch in zwei verschiedenen Ausführungen vorliegen.

Die Tischversion ist in zwei Versionen erhältlich: höhenverstellbar und nicht höhenverstellbar.

Die Bewegung wird von einem ganz aus Messing gefertigten Mechanismus gesteuert, der vollständig von Esperia entworfen und gebaut wurde.

Bei der Variante „Chandelier“ lässt sich die Höhe mit den Teleskopstangen in drei Stufen verstellen.

## Eirene Chandelier

### DIMENSION

Total Height: Customizable on 3 levels.

Central body diameter: 82cm / 32 In

Weight: 16 kg

### LIGHT SOURCES

7x GU10 Spot Led Max: 10W



85 cm  
33,5 in

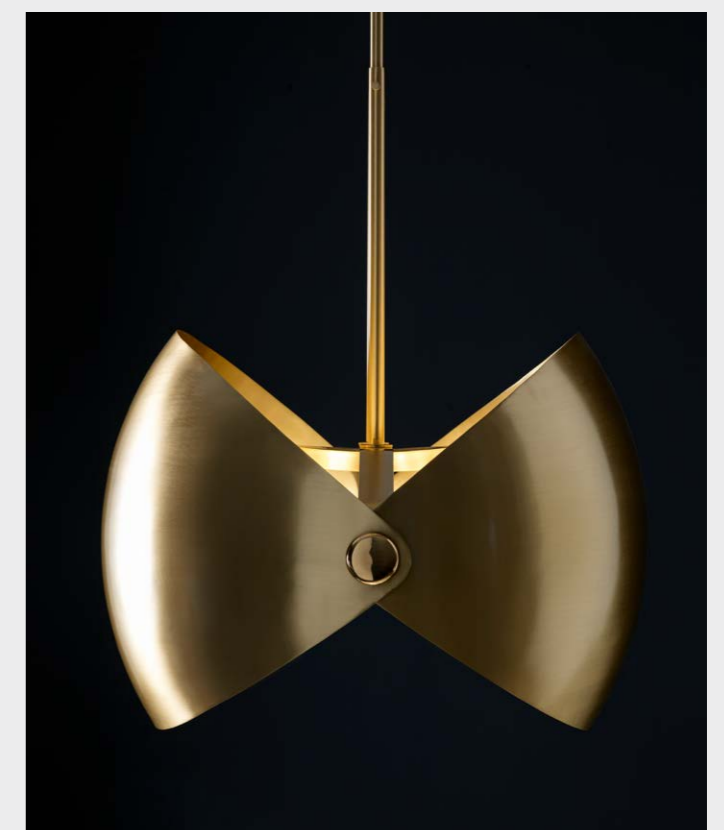



## EIRENE Table

### DIMENSION

Total Height: 150 cm / 59 In  
Central body diameter: 32cm / 12,5 In  
Weight: 10 kg

### LIGHT SOURCES

1x E27/E26 Led Max: 15W

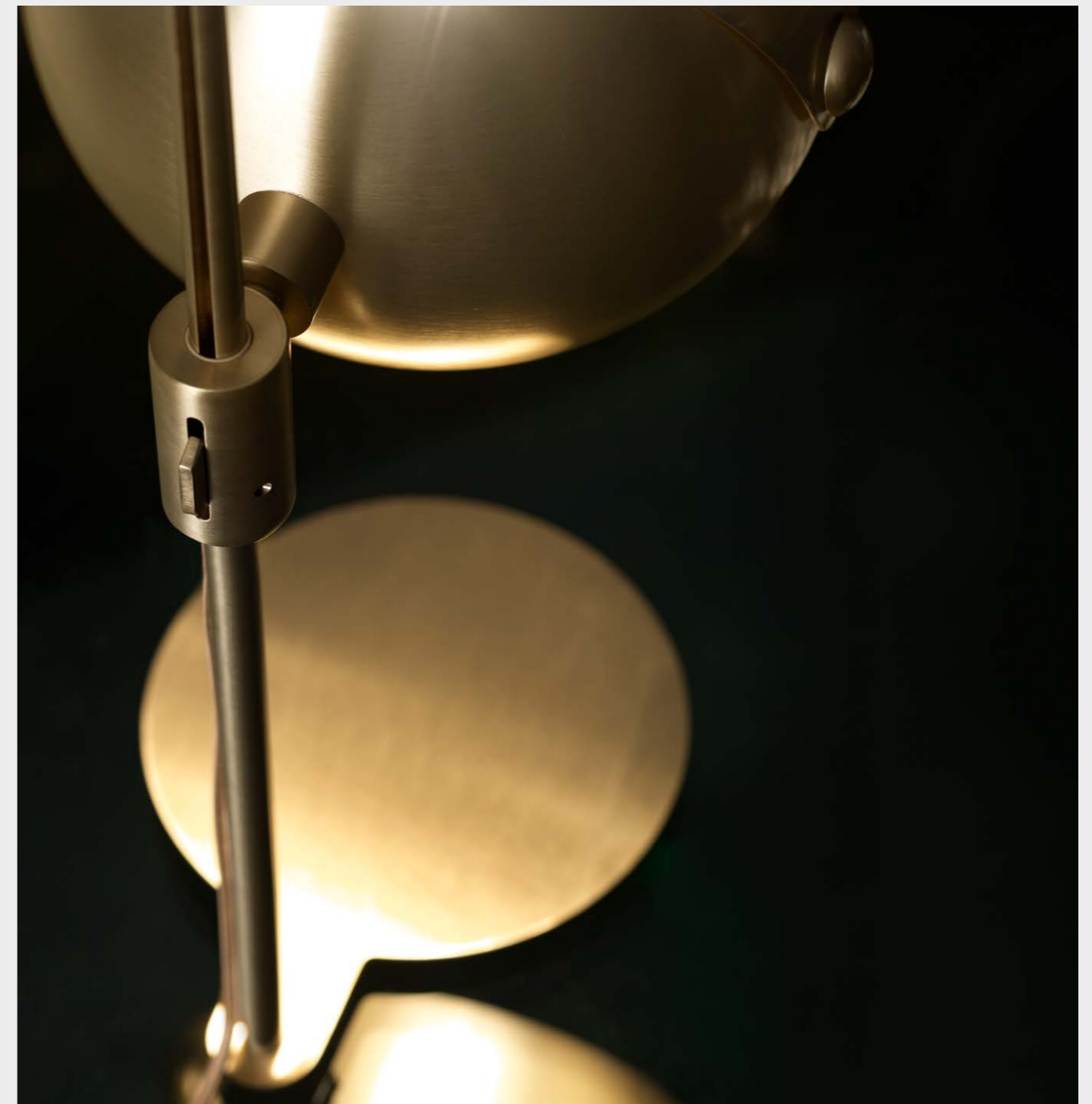
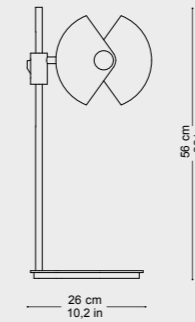





# EIRENE Floor

## DIMENSION

Total Height: 150 cm / 59 In  
Central body diameter: 32cm / 12,5 In  
Weight: 4 kg

## LIGHT SOURCES

2x G9 Led Max: 10W

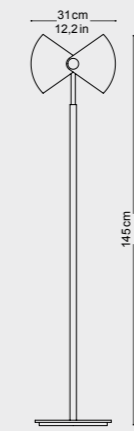



DAPHNE  
Centro Stile Esperia, 2020

# DAPHNE Table



# DAPHNE

Centro Stile Esperia, 2020

**IT.** Una lastra di ottone solido. Fresata e piegata. Un vetro bianco latte con finitura "Pulegoso". Abbiamo aggiunto materia, ricercatezza e carattere Esperia ad un design contemporaneo per creare una collezione che estremizza il concetto di design minimale di lusso. La versione da terra, è composta da due lastre unite, per creare un oggetto senza compromessi. Nelle versioni tavolo e sospensione, il vetro è regolabile lungo la fresatura.

**FR.** Une plaque de laiton solide. Fraisée et pliée. Un verre blanc lait avec une finition grêlée « pulegosa ». Nous avons ajouté les matériaux, le raffinement et le caractère d'Esperia à un design contemporain pour créer une collection qui pousse à l'extrême le concept de design de luxe minimaliste. La version sur pied est composée de deux plaques unies, pour créer un objet inouï. Dans la version de table et suspension, le verre est ajustable le long du fraisage.

**DE.** Eine massive Messingplatte. Gefräst und gefaltet. Ein weißes Milchglas mit Pulegoso-Finish. Wir haben Materie, Raffinesse und den Charakter von Esperia zu einem zeitgenössischen Design hinzugefügt, um eine Kollektion zu schaffen, die das Konzept des minimalen Luxus-Designs auf die Spitze treibt. Die Bodenversion besteht aus zwei miteinander verbundenen Platten, die ein kompromissloses Objekt schaffen. Bei den Tisch- und Pendelversionen ist das Glas entlang der Fräsung verstellbar.

**EN.** A solid brass plate. Milled and folded. Milky white glass with "pulegoso" finish. We have added Esperia's substance, refinement and character to a contemporary design to create a collection that takes the concept of minimal luxury design to an extreme. The floor version features two plates joined together to create an object without compromise. In the table and pendant versions, the glass globe can be slid along the groove.

**ES.** Una hoja de latón sólido. Fresada y plegada. Un vidrio blanco leche con acabado "pulegoso". Hemos agregado materia, refinamiento y carácter Esperia a un diseño contemporáneo para crear una colección que lleva al extremo el concepto de diseño minimalista de lujo. La versión de pie está compuesta por dos placas unidas, para crear un objeto sin igual. En las versiones de mesa y colgante, el vidrio puede regularse a lo largo de la ranura fresada.

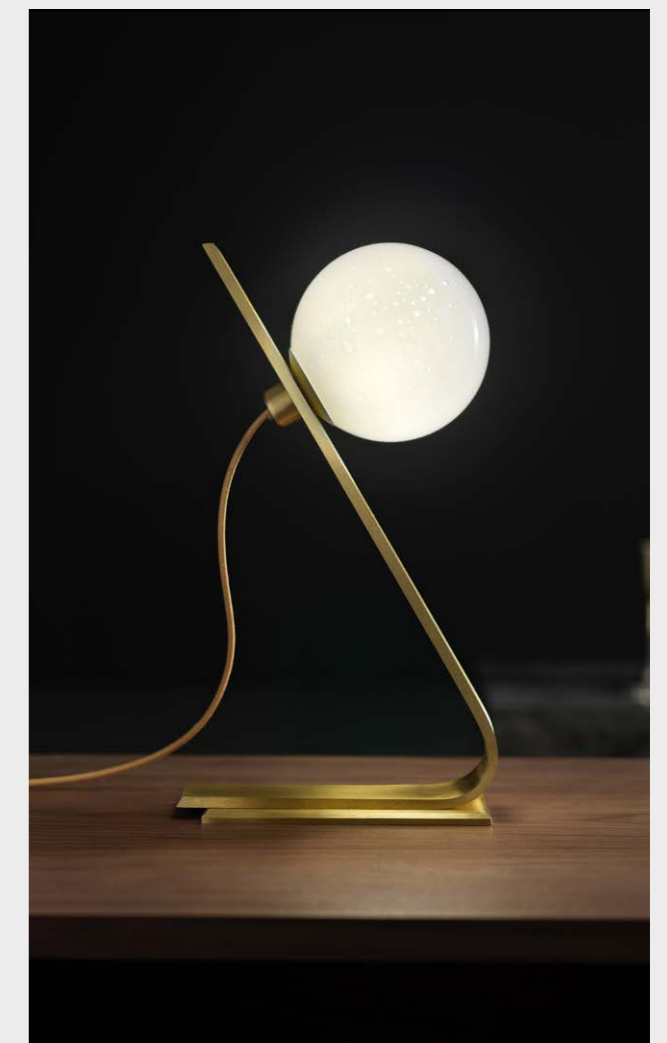

## DIMENSION

Height: H 40cm / 15 In  
Glass Diameter: 15 cm / 6 In  
Weight: 5 Kg

## LIGHT SOURCES

1x G9 Led: 10W

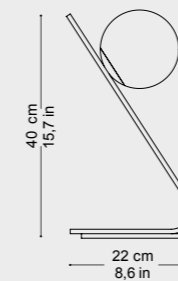



# DAPHNE Suspension

## DIMENSION

Height: H 75 cm / 29 In  
Glass Diameter: 30 cm / 12 In  
Weight: 10 Kg

## LIGHT SOURCES

1x E27/E26 Led Max: 30W

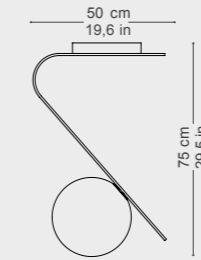



# DAPHNE

Floor

## DIMENSION

Height: H 155 cm / 61 In  
Glass Diameter: 30 cm / 12 In  
Weight: 23 Kg

## LIGHT SOURCES

1x E27/E26 Led Max: 30W

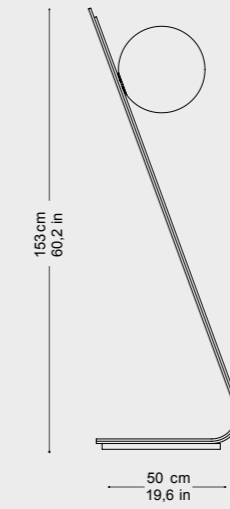



# DAPHNE Wall

## DIMENSION

Height: H 40 cm / 15 In  
Glass Diameter: 15 cm / 5,9 In  
Weight: 6 Kg

## LIGHT SOURCES

1x G9 Led Max: 10W

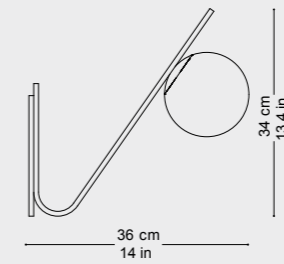



KIT  
Centro Stile Esperia, 2017



# KIT

Centro Stile Esperia, 2017

**IT.** Lampada scultura in ferro.  
E' disponibile nella versione ferro naturale cerato o ferro verniciato bianco. Possibili colorazioni custom.

**FR.** Lampe-sculpture en fer.  
Elle est disponible en version fer naturel ciré ou fer peint blanc. Possibilité de coloris personnalisés.

**DE.** Skulpturenleuchte aus Eisen.  
Erhältlich in Versionen aus gewachstem Natureisen oder weiß lackiertem Eisen. Benutzerdefinierte Farben sind möglich.

**EN.** Iron sculpture lamp.  
Available in the waxed natural iron or white painted iron version. Possible custom colours.

**ES.** Lámpara-esultura de hierro.  
Está disponible en la versión hierro natural encerado o hierro pintado de color blanco. Posibilidad de personalizar colores.

## DIMENSION

Height: 72 cm / 28,3 In  
Weight: 12 kg

## LIGHT SOURCES

1x E27/26 MAX 25W LED

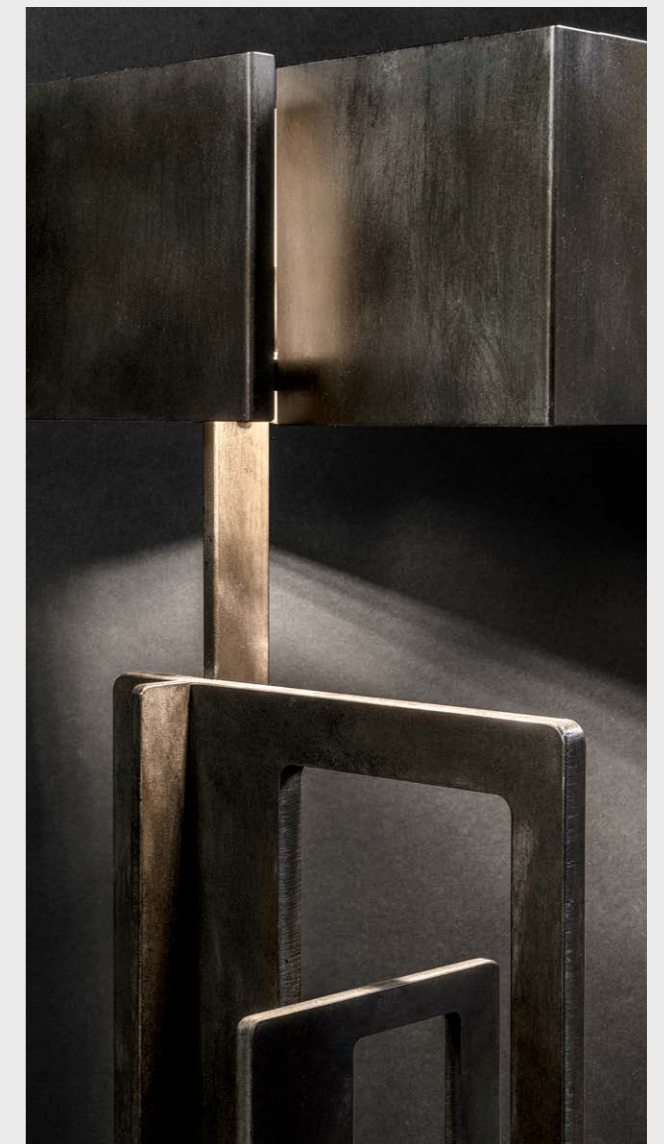
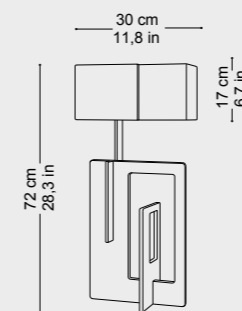



DIVA  
Centro Stile Esperia, 2020



**IT.** Design minimale con il carattere Esperia. Ogni vetro, realizzato a mano, è un manufatto unico. Diva è una lampada con il corpo cilindrico in ottone e vetri fatti a mano con fonte luminosa interna. All'estremità del corpo cilindrico, è posizionata una fonte luminosa da cui si origina un fascio di luce diretta.

**FR.** Design minimaliste sous le signe du caractère Esperia. Chaque verre, réalisé à la main, est une pièce unique. Diva est une lampe au corps cylindrique en laiton et verres faits main avec une source lumineuse intérieure. À l'extrémité du corps cylindrique est positionnée une source lumineuse de laquelle part un faisceau de lumière directe.

**DE.** Minimales Design mit dem Charakter von Esperia. Jedes von Hand gefertigte Glas ist ein Unikat. Diva ist eine Leuchte mit einem zylindrischen Körper aus Messing und handgefertigtem Glas mit interner Lichtquelle. Am Ende des zylindrischen Körpers ist eine Lichtquelle positioniert, von der ein direkter Lichtstrahl ausgeht.

**EN.** Minimal design with Esperia's character. Each handmade glass diffuser is truly unique. Diva is a lamp with a cylindrical brass structure and handmade glass diffusers with internal light source. A light source is placed at the end of the cylindrical structure and gives off a direct light beam.

**ES.** Diseño minimalista con el carácter de Esperia. Cada vidrio, hecho a mano, es una manufactura única. Diva es una lámpara con el cuerpo cilíndrico de latón y vidrios hechos a mano con fuente luminosa interna. En el extremo del cuerpo cilíndrico está ubicada una fuente luminosa de la que surge un haz de luz directa.

**DIMENSION**

Height: H 100cm / 39 In  
Weight: 9 kg

**LIGHT SOURCES**

3x G9 Led Max: 7W + 1x GU10 LED 4W

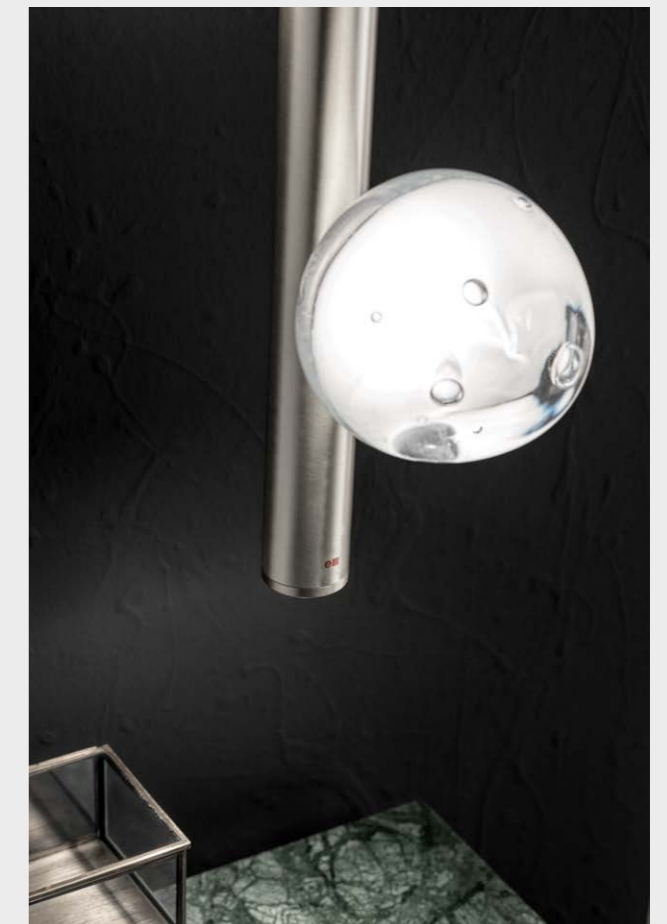
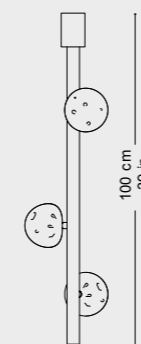



# DIVA Floor

## DIMENSION

Height: H 150cm / 59 In  
Weight: 20 kg

## LIGHT SOURCES

4x G9  
Led Max: 7W + 1x GU10 LED Max 4W

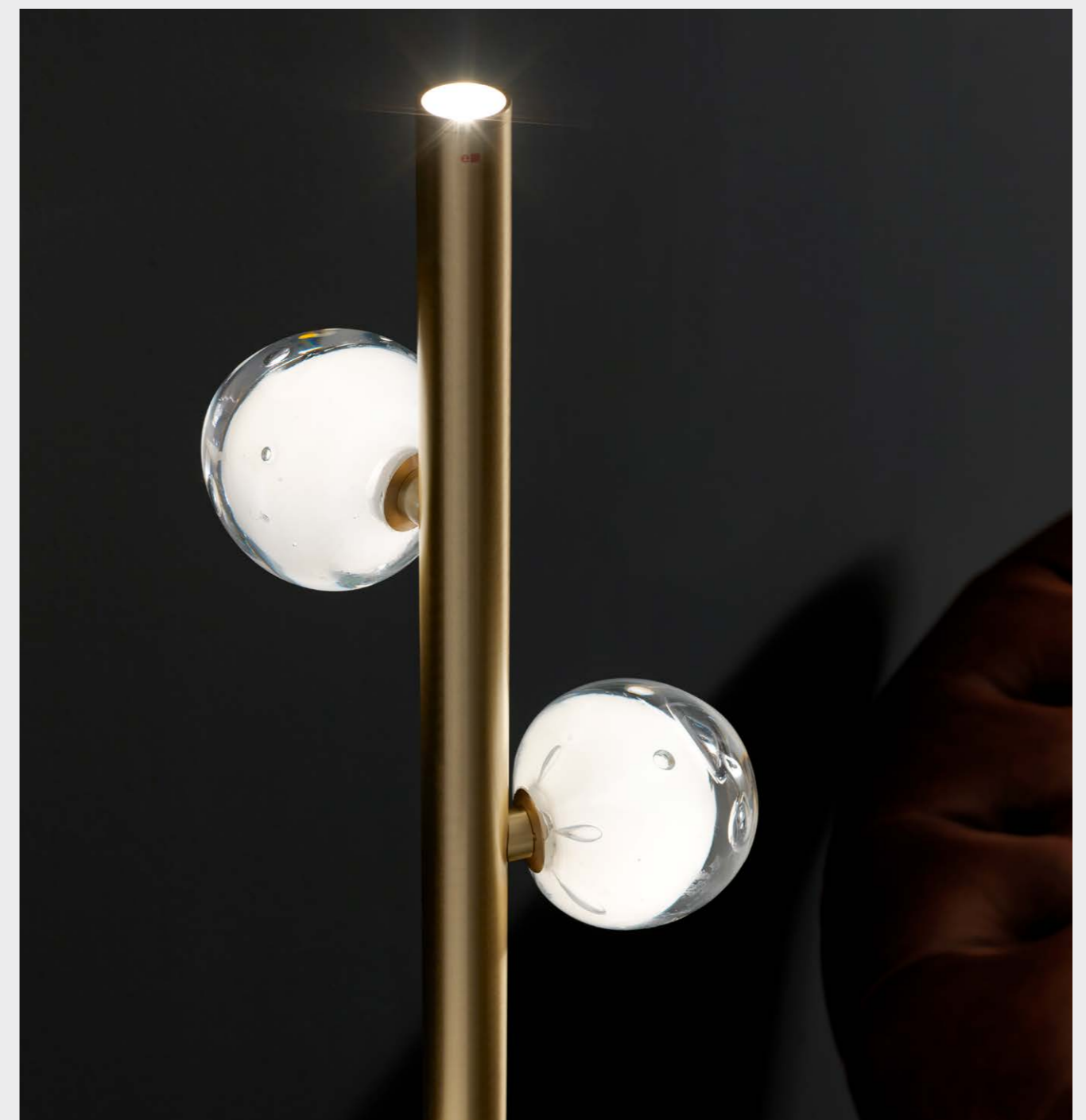
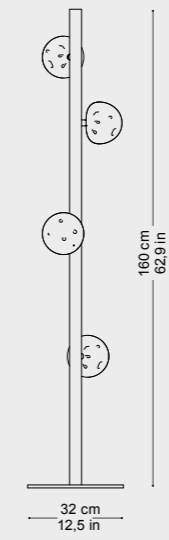



## DIVA Wall

### DIMENSION

Height: H 55cm / 21.1 in  
Weight: 6 kg

### LIGHT SOURCES

2x G9 Led: 7W + 2x GU10 LED 4W

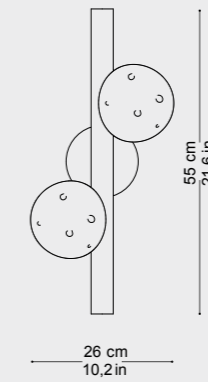



# LEILA

Design Cristina Celestino, 2019



## LEILA

Design Cristina Celestino, 2019

**IT.** Il progetto "Leila" coniuga le diverse anime di Esperia: l'aspetto scultoreo delle lampade, la presenza scenica, l'uso importante dei metalli con lavorazioni tecnicamente complesse e l'uso non convenzionale del vetro del distretto senese.

"Leila" si ispira infatti al seme di acero, il seme volante che arriva dallo spazio.

La struttura è in ottone, e le fonti luminose sono racchiuse all'interno dei vetri.

**FR.** Le projet « Leila » conjugue les différentes âmes d'Esperia : l'aspect sculptural des lampes, la présence scénique, l'utilisation prépondérante des métaux, avec des façons complexes, en termes techniques, et l'utilisation originale du verre du district siennois.

« Leila » s'inspire en effet de la graine d'érable, la graine volante qui arrive de l'espace.

La structure est en laiton et les sources lumineuses sont contenues dans les verres.

**DE.** Das Projekt „Leila“ vereint die verschiedenen Seelen von Esperia: den skulpturalen Aspekt der Leuchten, die szenische Präsenz, die bedeutende Verwendung von Metallen mit technisch komplexen Prozessen und die unkonventionelle Verwendung von Glas aus der Region um Siena.

"Leila" ist vom fliegenden Ahornsamen inspiriert, der aus dem Weltraum kommt. Die Struktur besteht aus Messing und die Lichtquellen sind in Glas eingeschlossen.

**EN.** "Leila" is a project that brings together the different souls of Esperia: the sculptural aspect of the lamps, the stage presence, the significant use of metals featuring a technically complex workmanship and the unconventional use of glass manufactured in the Sienese district. "Leila" is indeed inspired by the maple seed, the flying seed that comes from space.

The structure is made of brass, and the light sources are enclosed within glass elements.

**ES.** El proyecto "Leila" conjuga las diferentes esencias de Esperia: el aspecto escultórico de las lámparas, la presencia escénica, el importante uso de los metales con procesos técnicamente complejos y el uso no convencional del vidrio del distrito de Siena.

En efecto, "Leila" se inspira en la semilla de arce, la semilla voladora que viene del espacio.

La estructura es de latón y las fuentes luminosas están contenidas dentro de los vidrios.

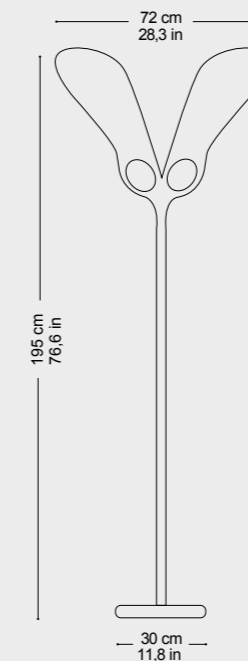

### DIMENSION

Height: 195 cm / 76,6 in

### LIGHT SOURCES

2 G9 Led 10 W





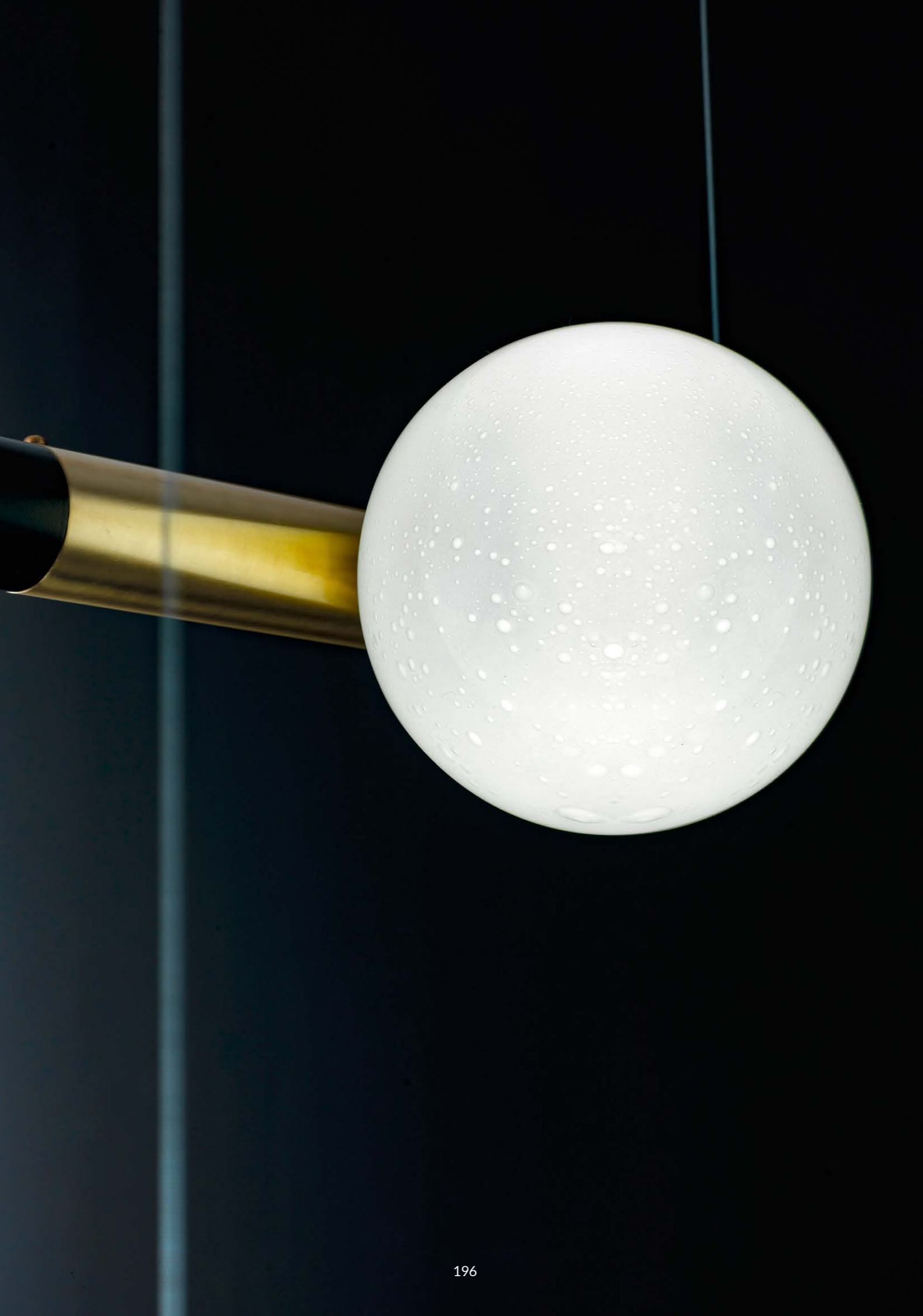

DIANA  
Centro Stile Esperia, 2020



# DIANA

Centro Stile Esperia, 2020

EN. Suspension lamp system composed of cylindrical brass structures. Configure your Diana by choosing the length, number of glass diffusers and the horizontal or vertical arrangement of the tubes. Each tube is available in a single finish (satin brass in the photos) or in a double finish. Diffusers in white milk glass with "Pulegoso" finish.

## Diana 4

### DIMENSION

4 Spheres  
Weight: 4 kg

### LIGHT SOURCES

4xG9 Led Max: 10W

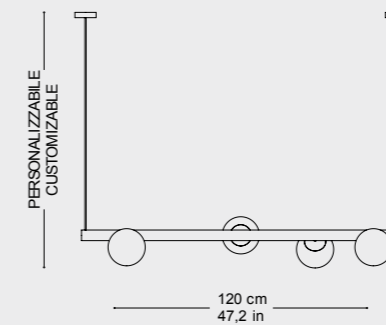

## Diana 3

### DIMENSION

3 Spheres  
Weight: 3,5 kg

### LIGHT SOURCES

3xG9 Led Max: 10W

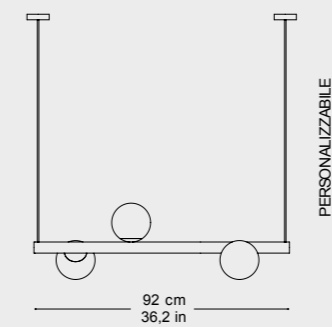

## Diana 2

### DIMENSION

2 Spheres  
Weight: 3 Kg

### LIGHT SOURCES

2xG9 Led Max: 10W

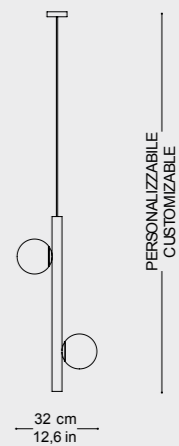

03

# MATERICA

DUE PIASTRE  
TRE PIASTRE  
TEA  
SASSONE  
GALILEO  
PITAGORA  
PULCINELLA  
MARGOT  
MIDA  
HEROD  
POTTER  
GRU  
LUCY  
OMAK  
WILLOW 8

UPDATE 2024 — PITAGORA WALL  
GONG  
METEORITE  
MEZZA SPERA  
XENON SUSPENSION  
ARGO SUSPENSION  
ARGO  
ELIO  
XENON WALL-CEILING  
QUASARS

# DUE PIASTRE TABLE

Centro Stile Esperia, 2015



202

## DIMENSION

Height: H 77 cm / 30,3 In  
Glass Diameter: 30 cm / 12 In  
Weight: 10 Kg

## LIGHT SOURCES

1xE26/E27 Led Max: 25W

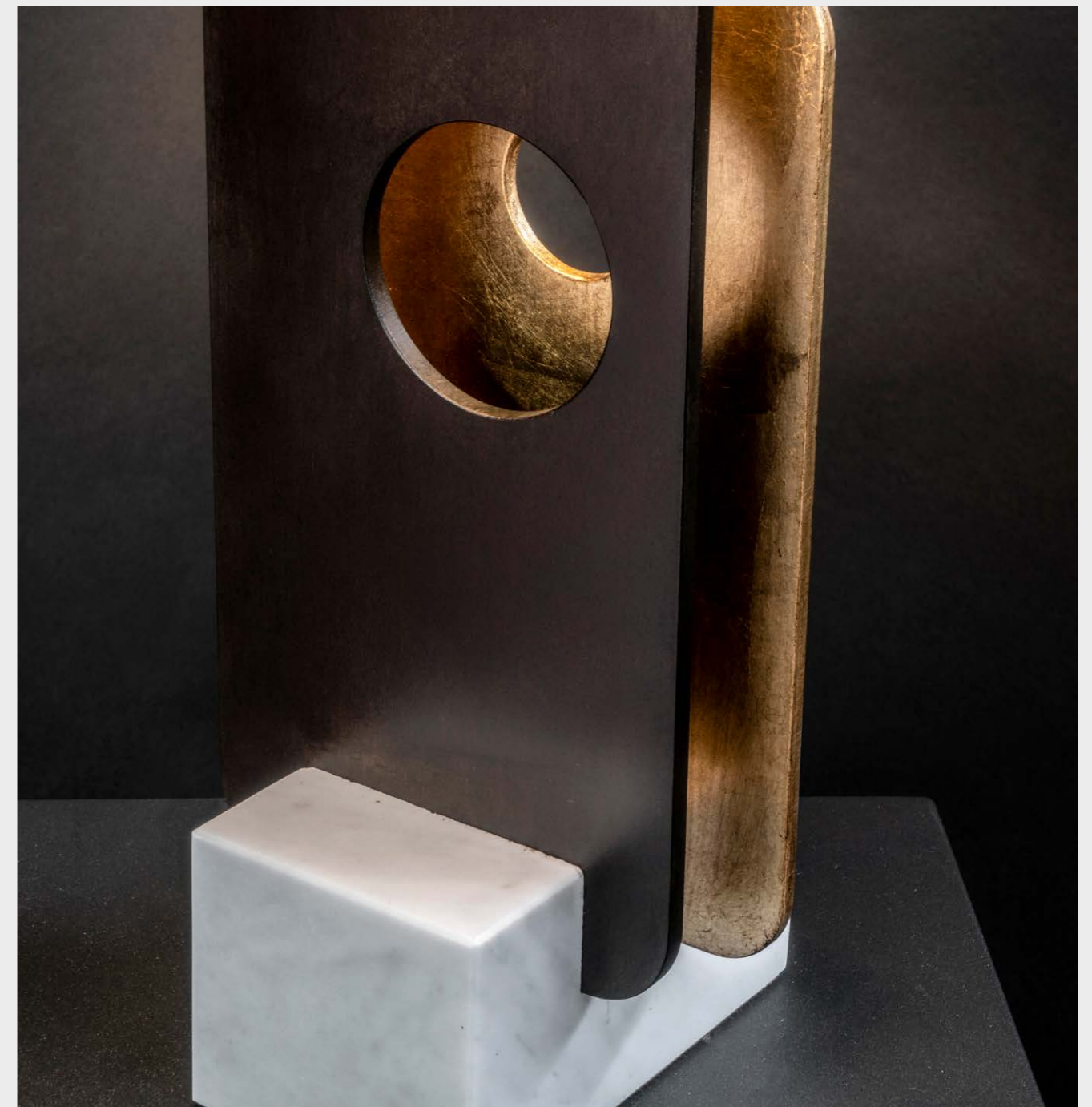
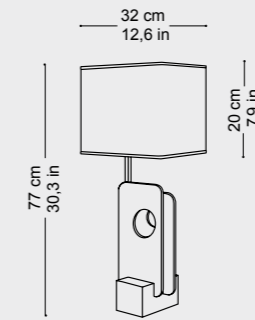

203

# TRE PIASTRE TABLE

Centro Stile Esperia, 2015

## DIMENSION

H 72 cm | 28 in

## LIGHT SOURCES

2x E26/e27

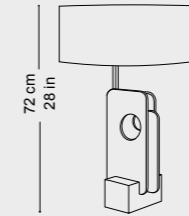

# TEA TABLE

Centro Stile Esperia, 2020



## DIMENSION

Height: H 71,5 cm / 28 In

## LIGHT SOURCES

2x E26/e27

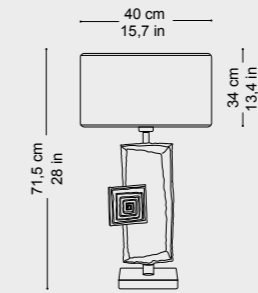

# SASSONE TABLE

Centro Stile Esperia, 2015



## DIMENSION

Height: 66 cm / 26 in  
Weight: 10 kg

## LIGHT SOURCES

1x E27/26 MAX 25W LED

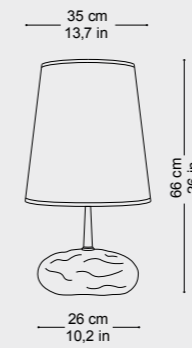

# GALILEO TABLE

Centro Stile Esperia, 2015

**DIMENSION**  
Height: H 81 cm / 32 In

**LIGHT SOURCES**  
1E27 x max 25W

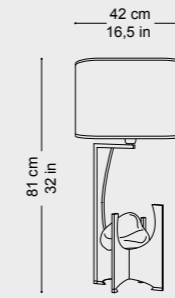



# PITAGORA TABLE

Centro Stile Esperia, 2014

**DIMENSION**  
Height: 94 cm / 37 In

**LIGHT SOURCES**  
2 E27 Max 25W

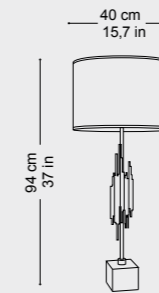



214

## PULCINELLA TABLE

Design Silvano Pulcinelli, 1974

### DIMENSION

Height: 73,5 cm / 39,3 In

### LIGHT SOURCES

2 E27 Max 25W

CE

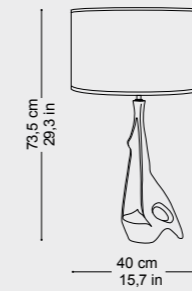

215

# MARGOT TABLE

Design Angelo Brotto, 1975

**DIMENSION**  
Height: 65 cm / 25,6 In

**LIGHT SOURCES**  
2 E27 Max 25W

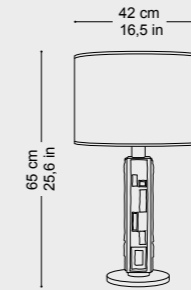

# MIDA TABLE

Centro Stile Esperia, 2017

**DIMENSION**  
Height: 70 cm / 27,6 In

**LIGHT SOURCES**  
2 E27 Max 25W

CE

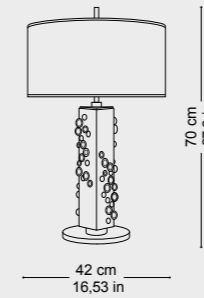

# HEROD TABLE

Centro Stile Esperia, 2013



**DIMENSION**  
Height: 86,5 cm / 34 In

**LIGHT SOURCES**  
2 E27 Max 25W

CE

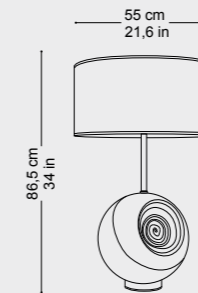

# POTTER TABLE

Centro Stile Esperia, 2018

## DIMENSION

Height: H 82 cm / 32,3 In

## LIGHT SOURCES

2 E27 Max 25W

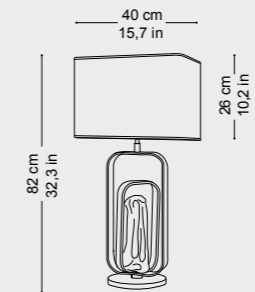

# GRU TABLE

Centro Stile Esperia, 2017

## DIMENSION

Height: 70 cm / 27,5 In  
Weight: 10 kg

## LIGHT SOURCES

3x E27/26 MAX 25W LED

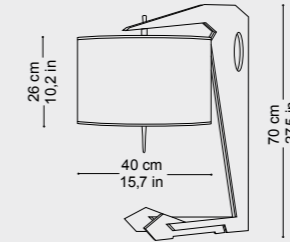

# LUCY SUSPENSION

Centro Stile Esperia, 2012

## DIMENSION

Height: Personalizzabile customizabile

## LIGHT SOURCES

2x GU10 LED Max 10W

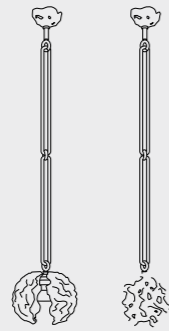

# OMAK SUSPENSION

Centro Stile Esperia, 2018

## DIMENSION

Height: 65 cm / 25,5 In

## LIGHT SOURCES

24v - 30W LED - 3000k

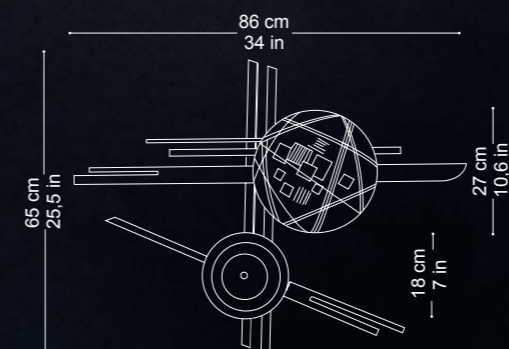



## WILLOW 8 SUSPENSION

Centro Stile Esperia, 2020

### DIMENSION

Height: 85 cm / 33,5 In  
Weight: 7 kg

### LIGHT SOURCES

8x G9 LED

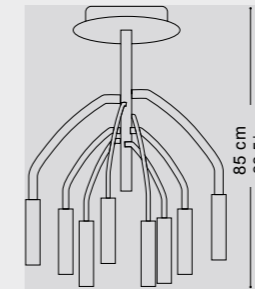

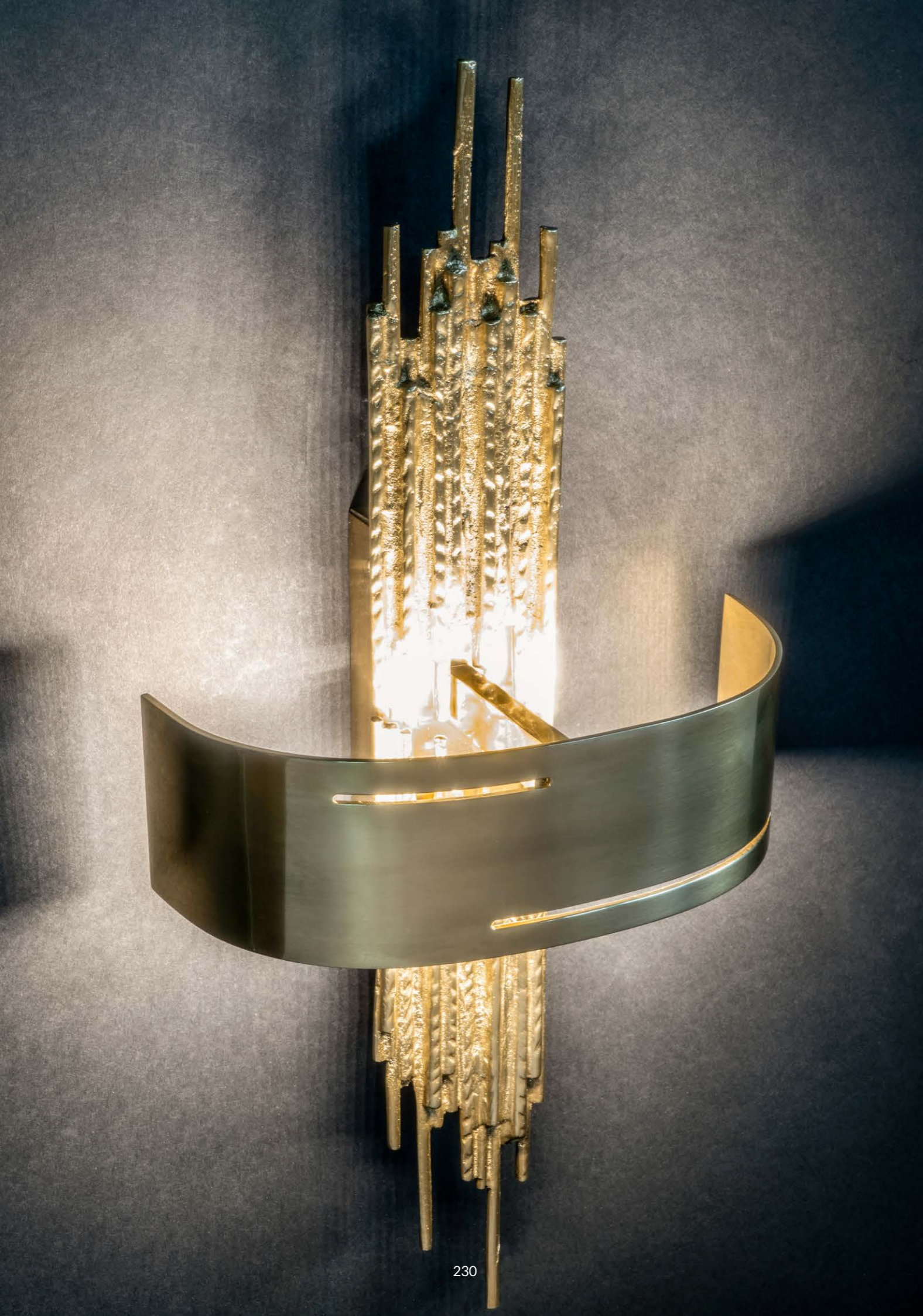

# PITAGORA WALL

Centro Stile Esperia, 2014

## DIMENSION

Height: 46 cm / 18 In  
Width: 23cm / 9 In  
Depth: 12cm / 4.75"

Weight: 2 kg

LIGHT SOURCES  
3000k - LED 5W

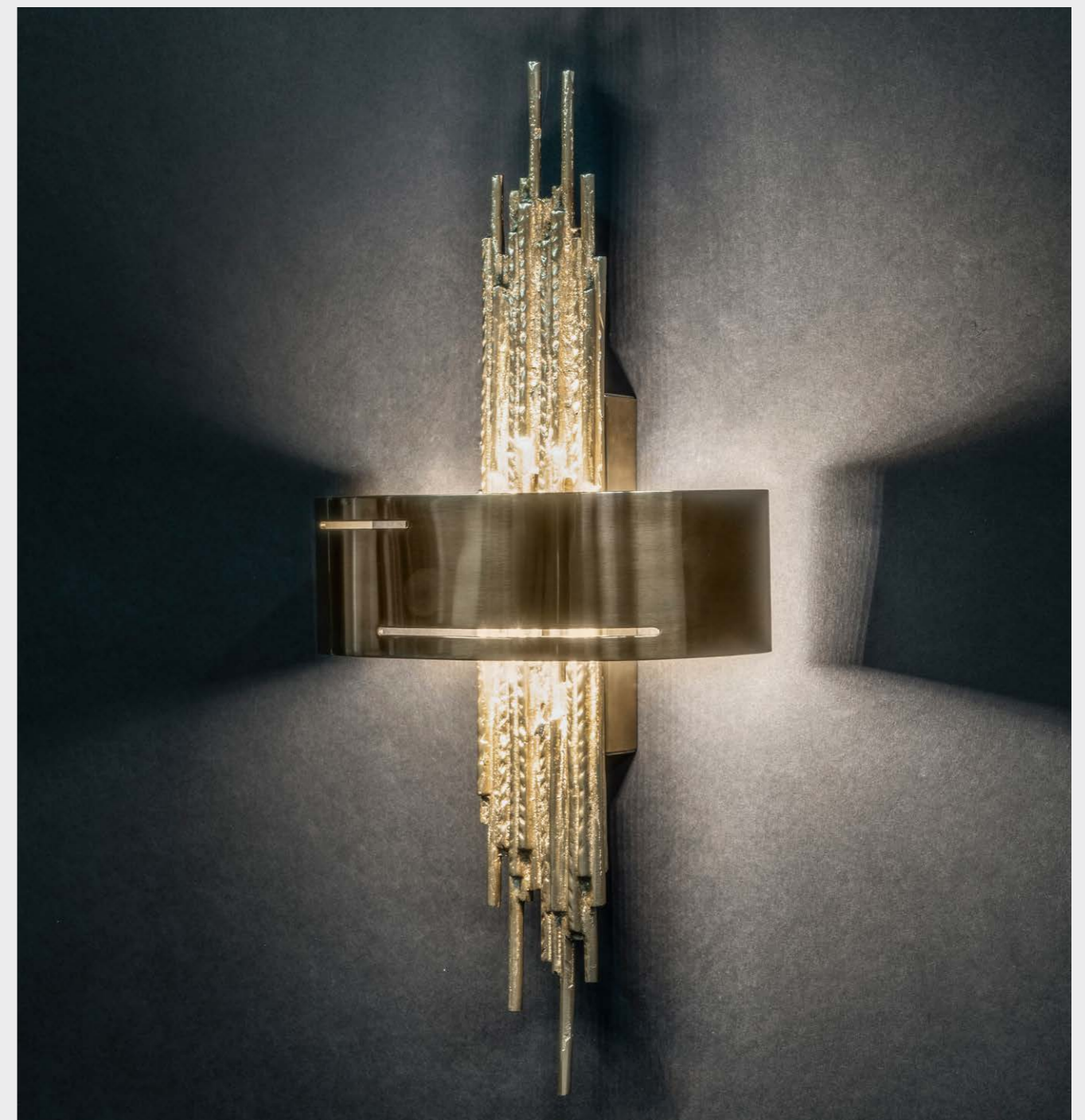
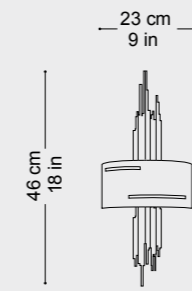

# GONG WALL

Centro Stile Esperia, 2018

## DIMENSION

Height: H 46 cm / 18 In

## LIGHT SOURCES

24v - 20W LED - 3000k

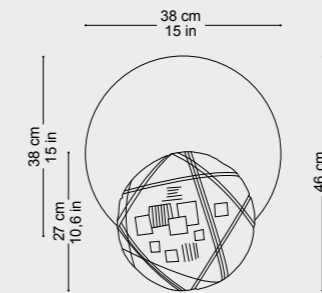

# METEORITE WALL

Centro Stile Esperia, 2011

## DIMENSION

Height: 21 cm / 13,7 In

## LIGHT SOURCES

1x G9 LED MAX 10W

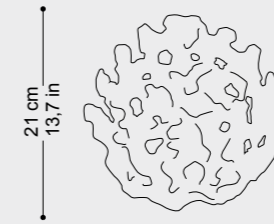

CE

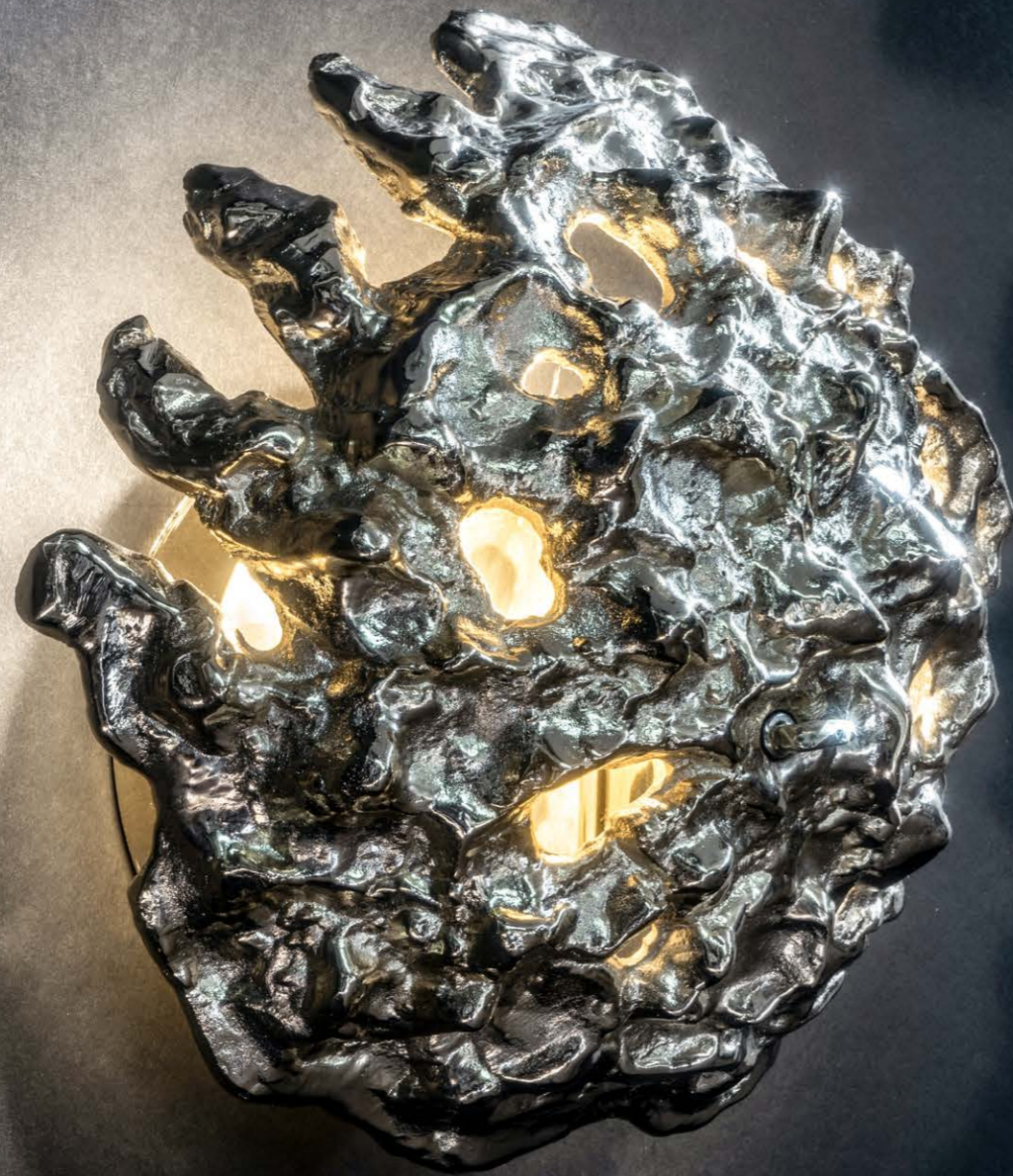

# MEZZA SFERA WALL

Centro Stile Esperia, 2011

## DIMENSION

Height: 40 cm / 15,7 in

## LIGHT SOURCES

1x E27/E26 LED Max 30W

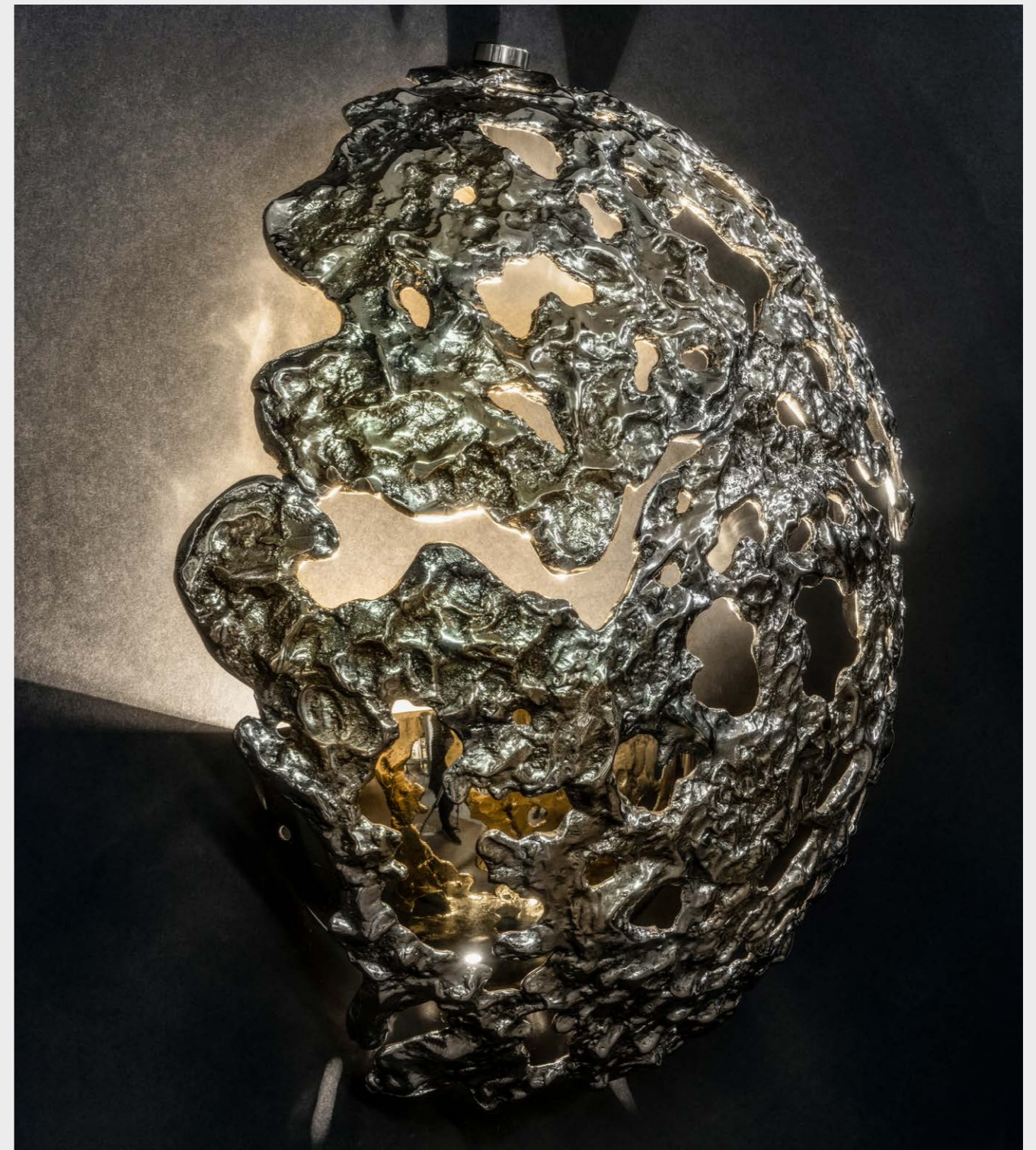
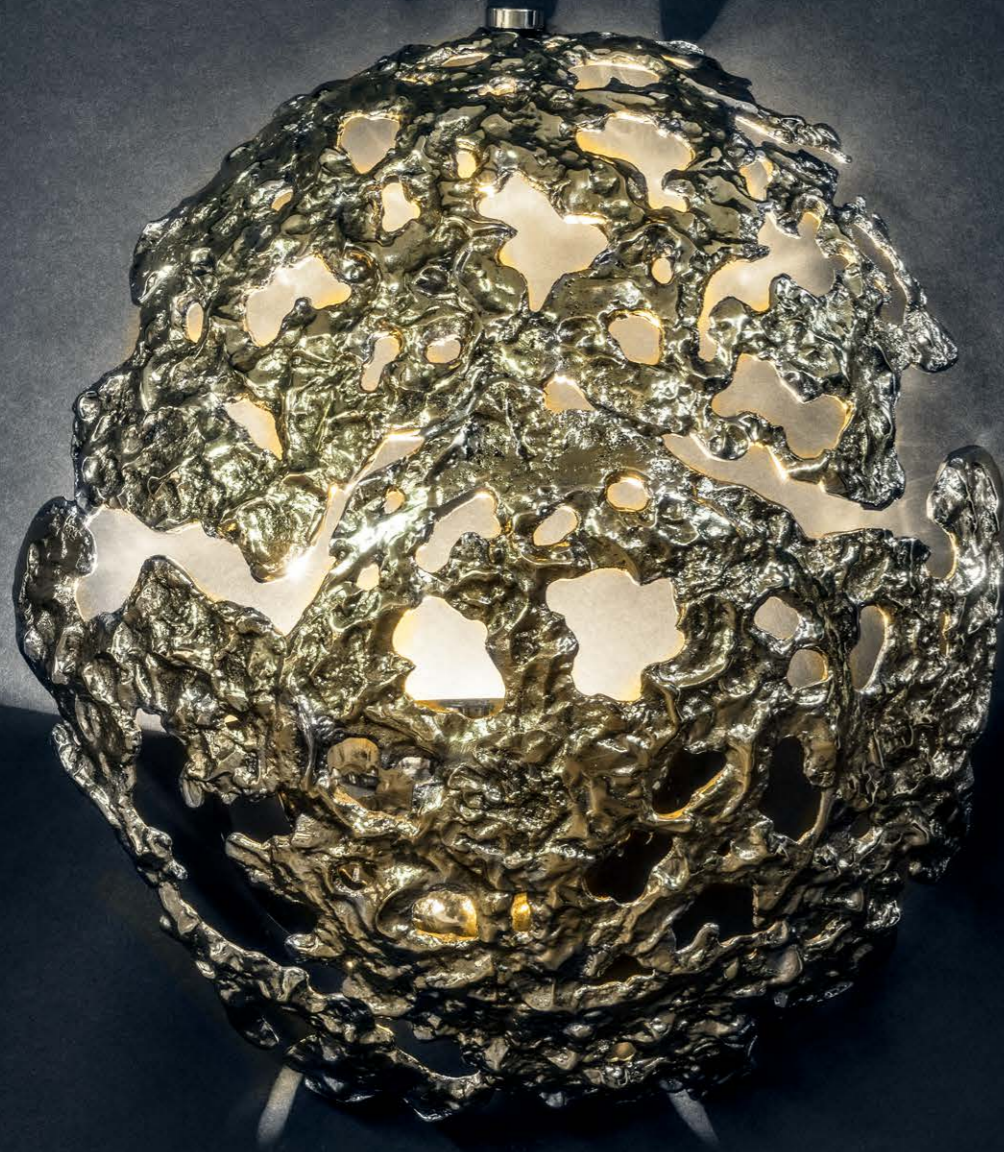
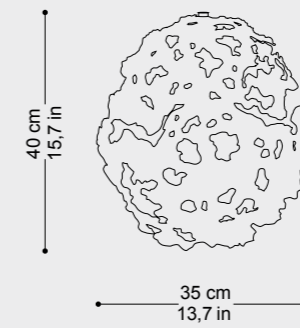

# XENON SUSPENSION

Centro Stile Esperia, 2021



## DIMENSION

Available in the ceiling,  
wall and suspension version.

## LIGHT SOURCES

1x E27/E26 Led Max: PAR30S MAX 20W



# ARGO SUSPENSION

Centro Stile Esperia, 2021

## DIMENSION

Available in the ceiling,  
wall and suspension version.

## LIGHT SOURCES

1x E27/E26 Led Max: PAR30S MAX 20W



ARGO WALL - CEILING

Centro Stile Esperia, 2021

DIMENSION

Height: 15 cm / 5,9 In  
Max Diameter: 10 cm / 3,9 In

LIGHT SOURCES

1x E27/E26 Led Max: PAR30S MAX 20W

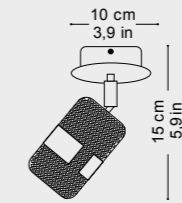

# ELIO WALL - CEILING

Centro Stile Esperia, 2021



## DIMENSION

Height: 80 cm / 32,5 In  
Max Diameter: 64 cm / 25 In  
Weight: 7 kg

## LIGHT SOURCES

8x G9 Led Max: 10W

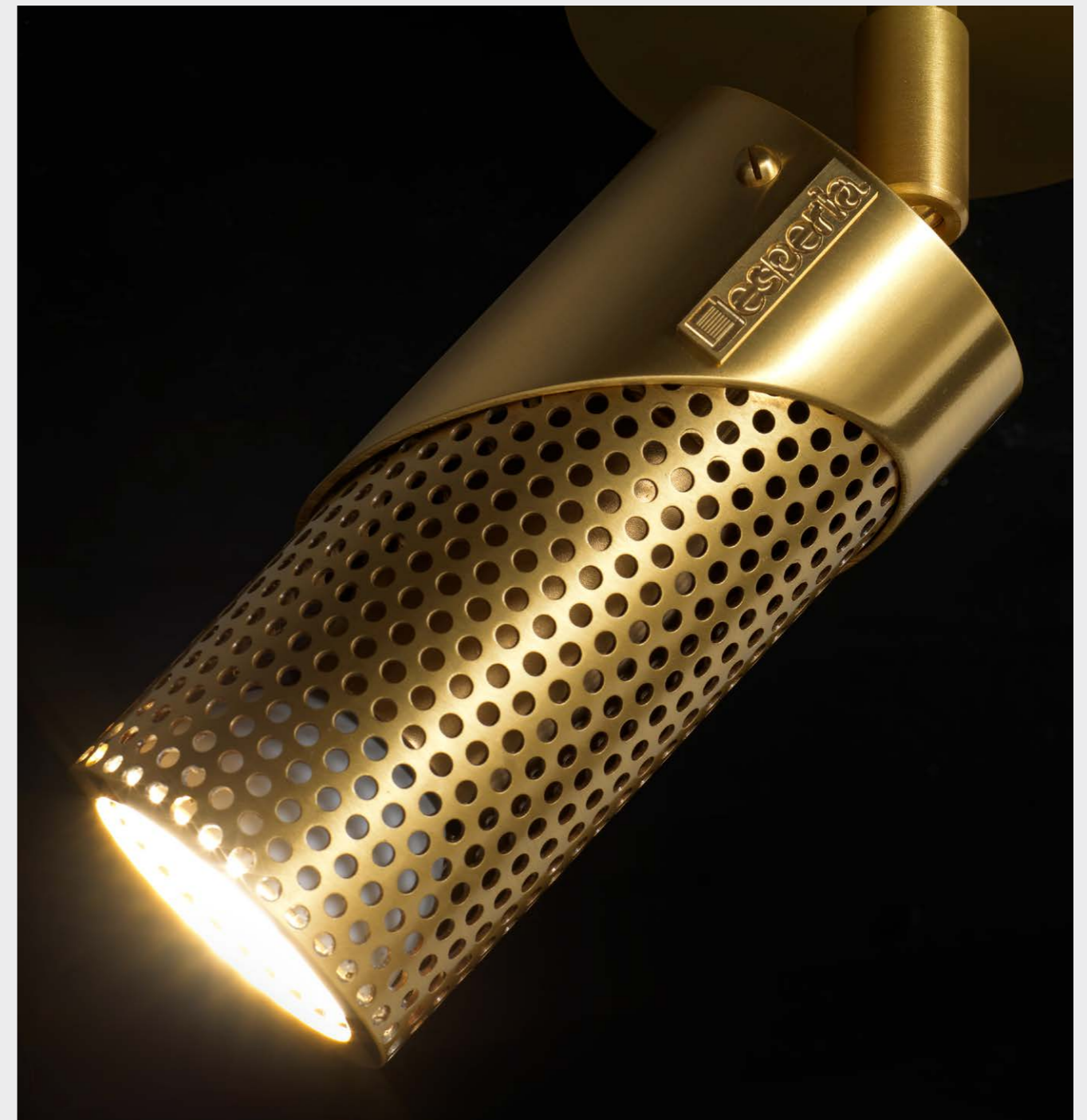
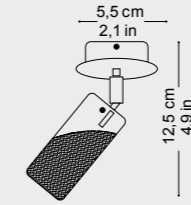

# XENON WALL - CEILING

Centro Stile Esperia, 2021

## DIMENSION

Height: 13 cm / 5,1 In

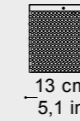

## LIGHT SOURCES

1x E27/E26 Led Max: PAR30S MAX 20W

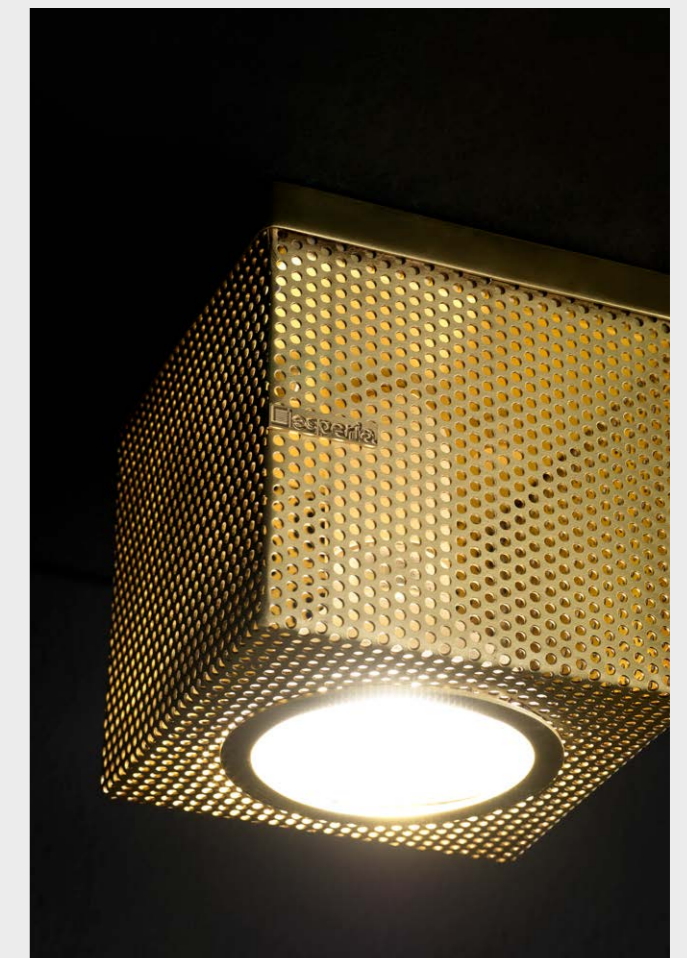
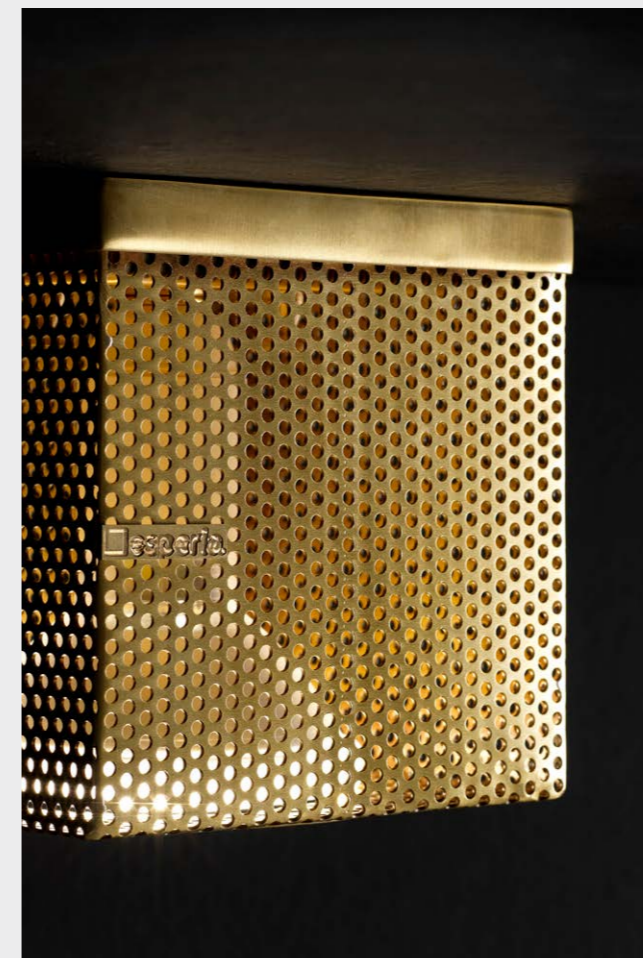
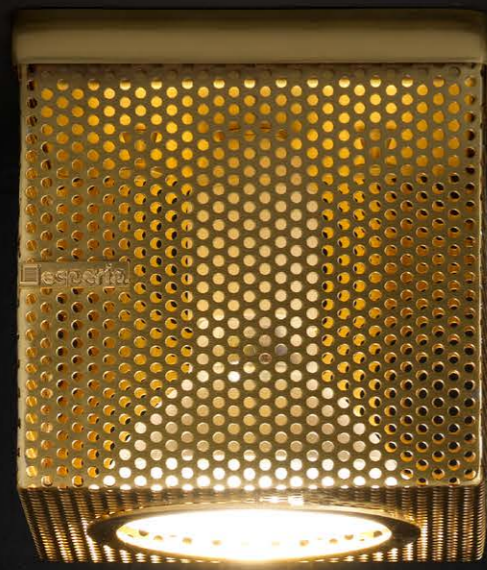

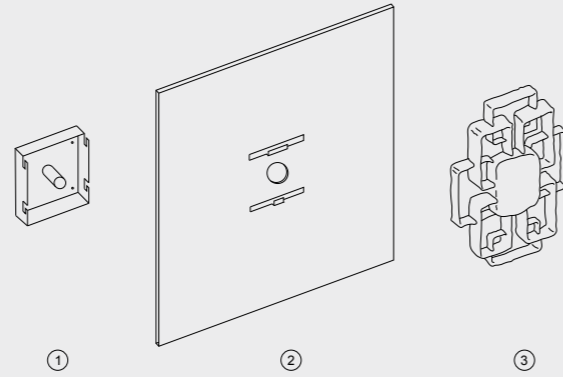

“The term quasar originated as a contraction of QUASI-stellar radio source. It indicates an extremely luminous active galactic nucleus (AGN), generally very distant from the Earth. The name comes from the fact that these objects were initially discovered as powerful sources of radio-wave emission of unknown physical origin, and at visible wavelengths they resembled faint star-like points of light.

Their extreme redshift could imply great distance and velocity. It is commonly believed that their great luminosity comes from the friction caused by gas and dust falling into a massive black hole.

The first quasars were discovered with radio telescopes at the start of the 1960s and the term QUASAR was first used in a paper in 1964 by the astrophysicist Hong- Yee Chiu.”



The artistic collaboration with Angelo Brotto reaches its highest expressive impact in the collection of luminous sculptures known as Quasars. The historical period of reference is the late 1960s, when the artist began to explore the idea of making works that could act as a point of contact between lighting fixtures and artistic compositions.

In a historical context marked by a widespread focus on the universe driven by the reaction to the first space missions, these luminous creations were born, under the name Quasar.

The Quasars are objects with precise forms and a forceful theatrical presence, capable of adding character to any setting. This is because the artistic value of the works is not limited to their technical lighting function: each piece was formulated by Angelo Brotto as the result of a precise inspiration, based on his remarkable spirit of observation. The Quasars collection, presented at Euroluce during the Salone del Mobile, is a sort of gallery of wall-mounted artworks, of large size, featuring an unexpected and unconventional use of Murano glass combined with brass castings, on geometric metal supports with clean lines in a range of different finishes.

These luminous creations, which have become symbols of Esperia in the world, were also the result of the company’s ongoing collaboration with important glassworks in Murano, such as Venini and Moretti.

The light filtered through the often colorful irregular glass crystals, which seem like objects from outer space, makes these timeless works even more ethereal and surreal.

Today, Esperia still reissues the historic Quasars, rigorously based on the original drawings by Angelo Brotto, with the same fine workmanship as in the past, often relying on the very same glassworks over the years. The present catalogue features some of the most important pieces, like Mattino d’Inverno, Oceano and Fantasia Notturna.

# BIAGIO

Design Angelo Brotto, 1973



## DIMENSION

Height: 80x80 cm / 31,5x31,5 In

## LIGHT SOURCES

2x E27/E26 Led Max: 25W

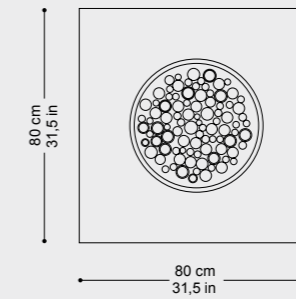

The Quasars are objects with precise forms and a forceful theatrical presence, capable of adding character to any setting. This is because the artistic value of the works is not limited to their technical lighting function: each piece was formulated by Angelo Brotto as the result of a precise inspiration, based on his remarkable spirit of observation.

The Quasars collection, presented at Euroluce during the Salone del Mobile, is a sort of gallery of wall-mounted artworks, of large size, featuring an unexpected and unconventional use of Murano glass combined with brass castings, on geometric metal supports with clean lines in a range of different finishes.



# OCEANO

Design Angelo Brotto, 1973

## DIMENSION

Height: 80x80 cm / 31,5x31,5 In

## LIGHT SOURCES

2x E27/E26 Led Max: 25W

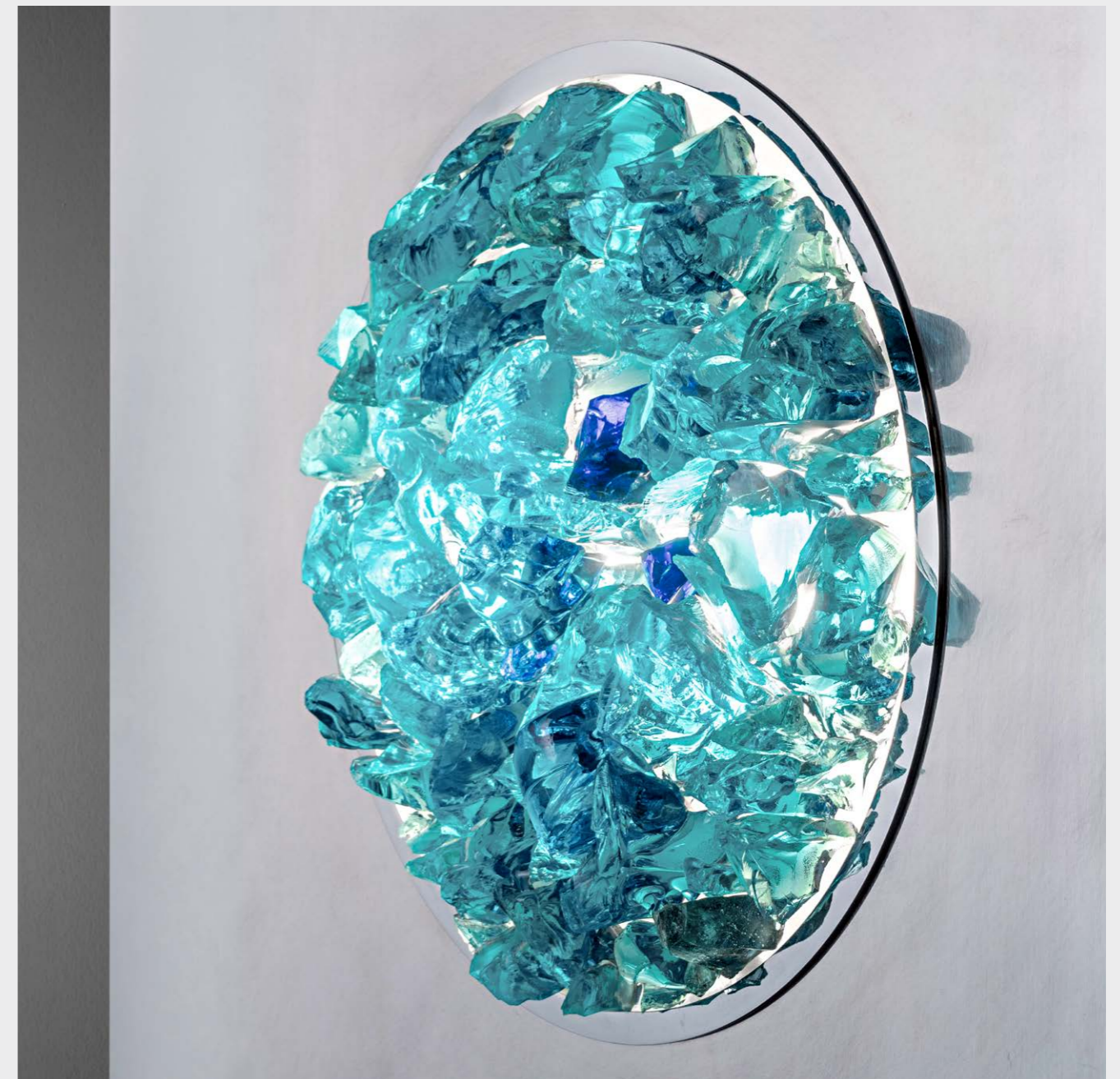
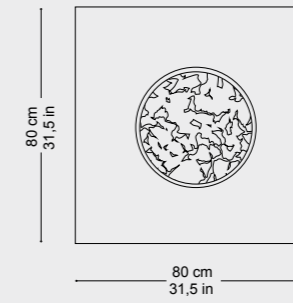



# MALIZIA

Design Angelo Brotto, 1973

**DIMENSION**  
Height: 80x80 cm / 31,5x31,5 In

**LIGHT SOURCES**  
5x G9 LED Max 10W

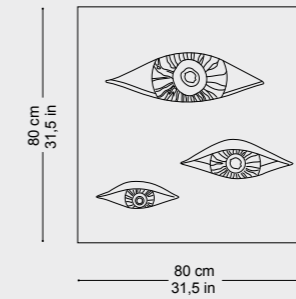

# MATTINO D'INVERNO

Design Angelo Brotto, 1989

## DIMENSION

Height: 80x80 cm / 31,5x31,5 in

## LIGHT SOURCES

2x G9 LED Max 10W

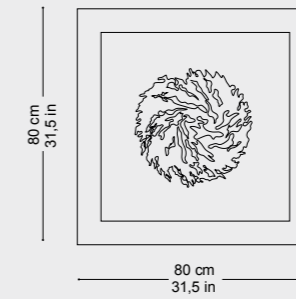

# NEVE DI PRIMAVERA

Design Angelo Brotto, 1974

## DIMENSION

Height: 80x80 cm / 31,5x31,5 In

## LIGHT SOURCES

2x E27/E26 LED Max 20W

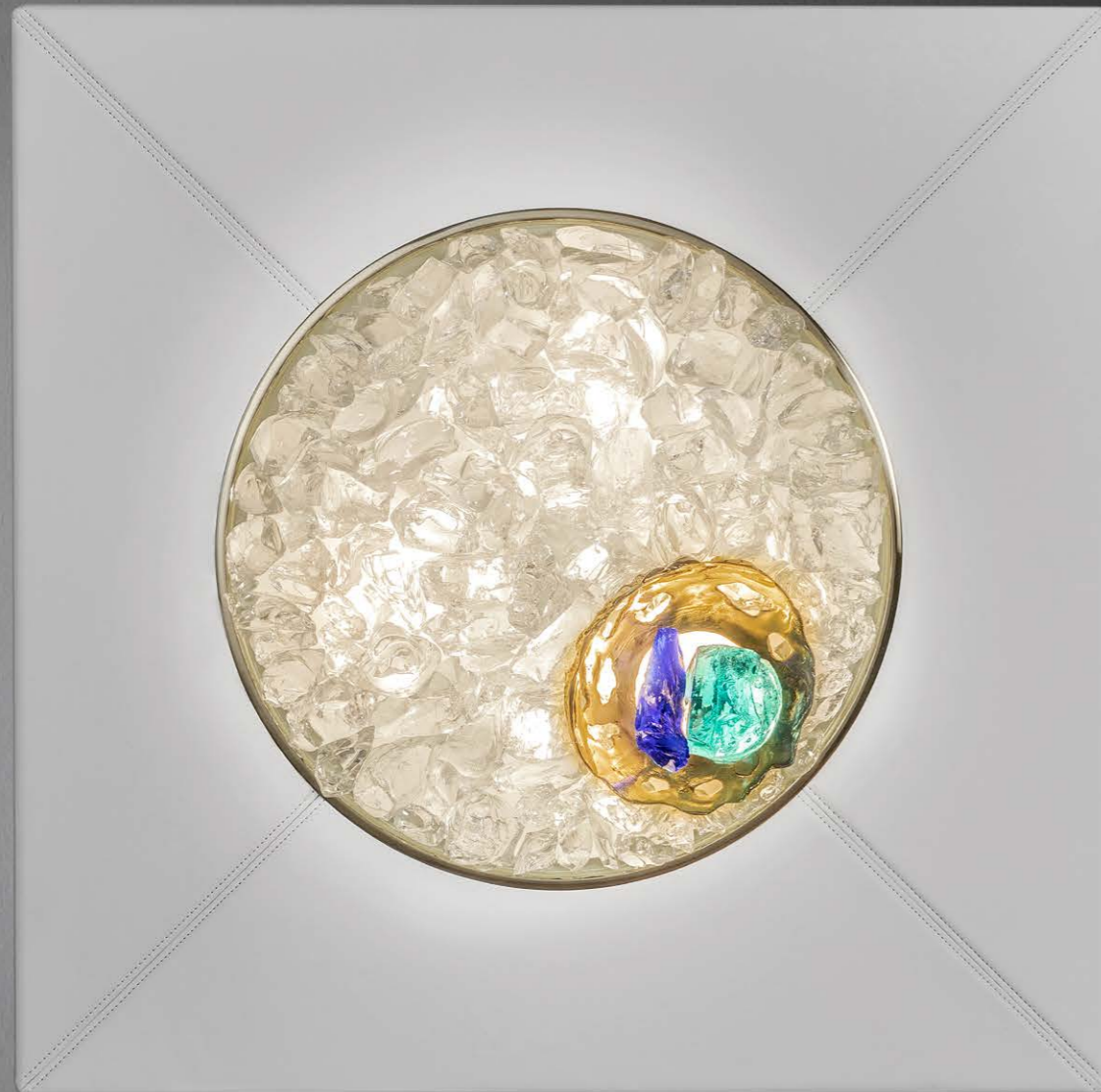
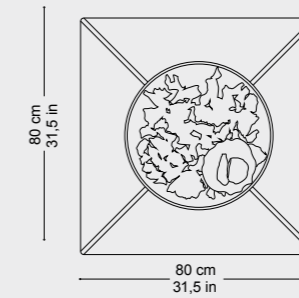

# BOLLE IN ARIA

Design Angelo Brotto, 1972

## DIMENSION

Height: 80x80 cm / 31,5x31,5 In

## LIGHT SOURCES

2x G9 LED Max 10W

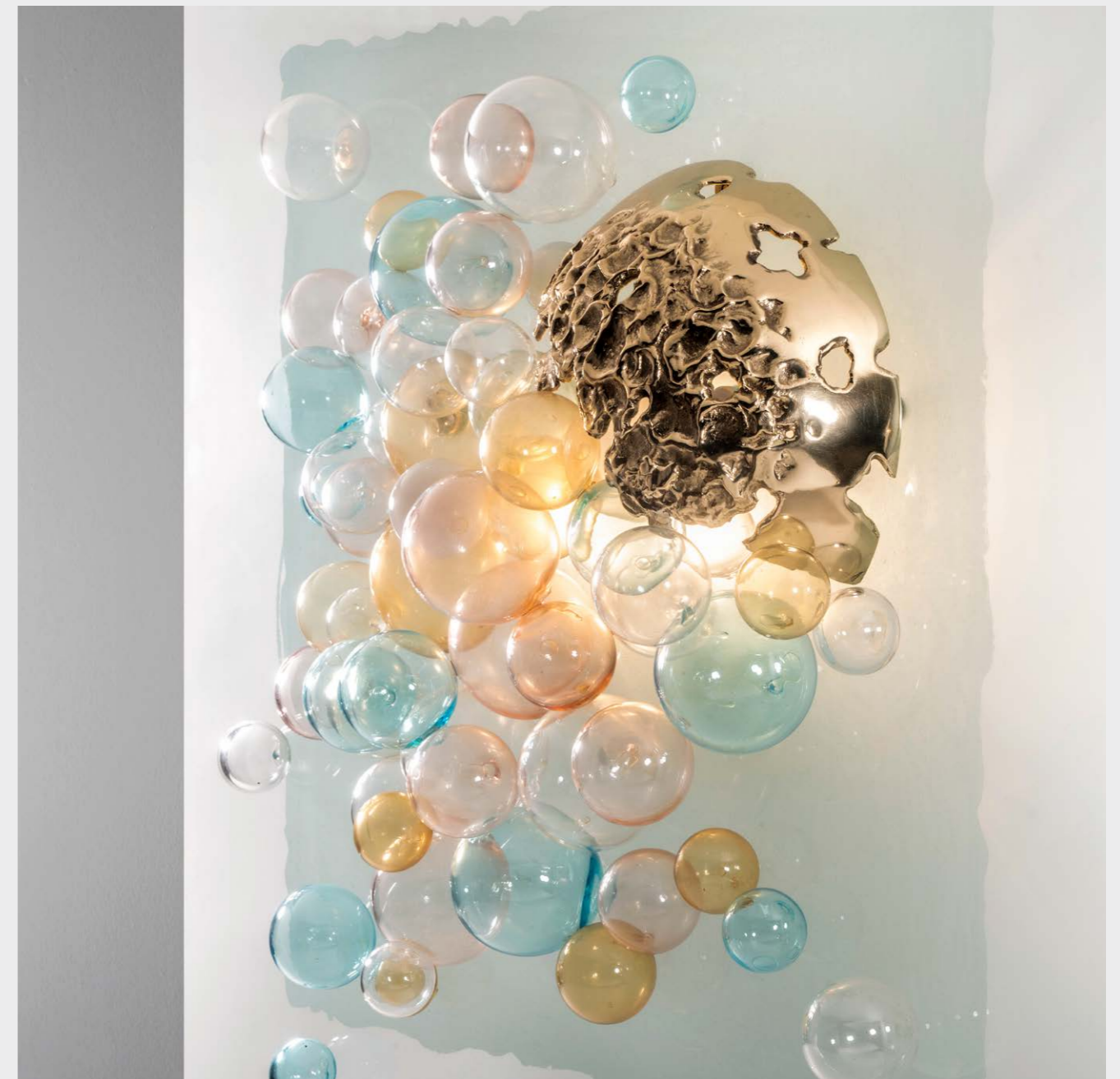
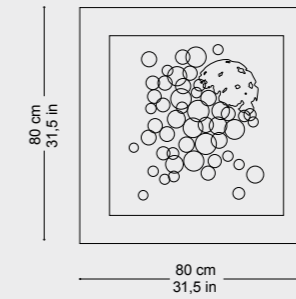

# FANTASIA NOTTURNA

Design Angelo Brotto, 1972

## DIMENSION

Height: 80x80 cm / 31,5x31,5 In

## LIGHT SOURCES

1x E27/E26 LED Max 20W

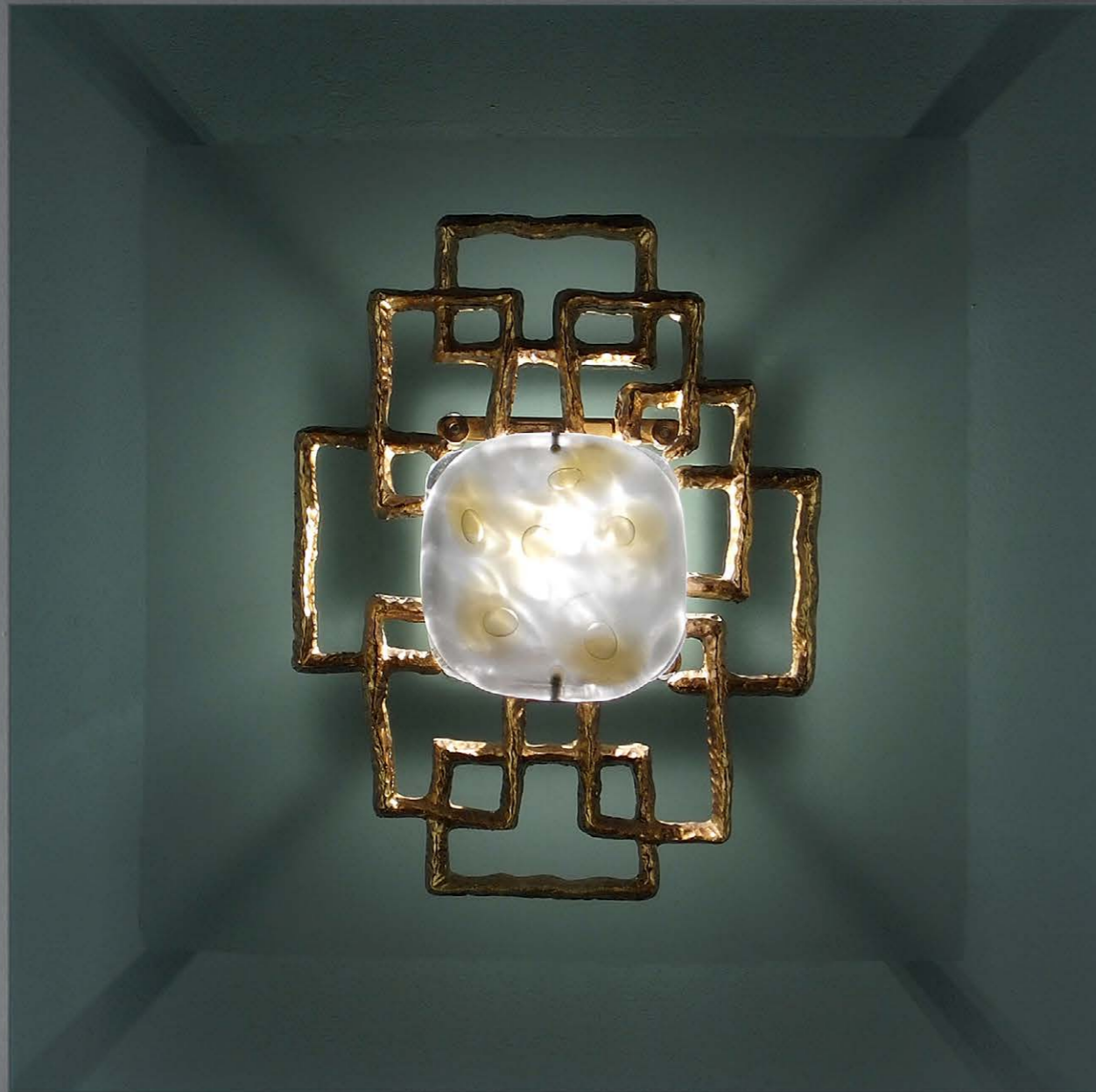
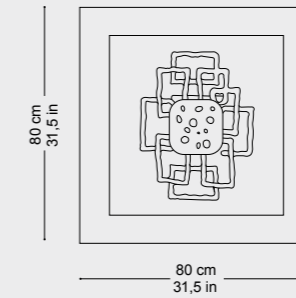

04

## CUSTOM ICONS

"Crea la tua lampada iconica"  
"Create your own iconic lamp"

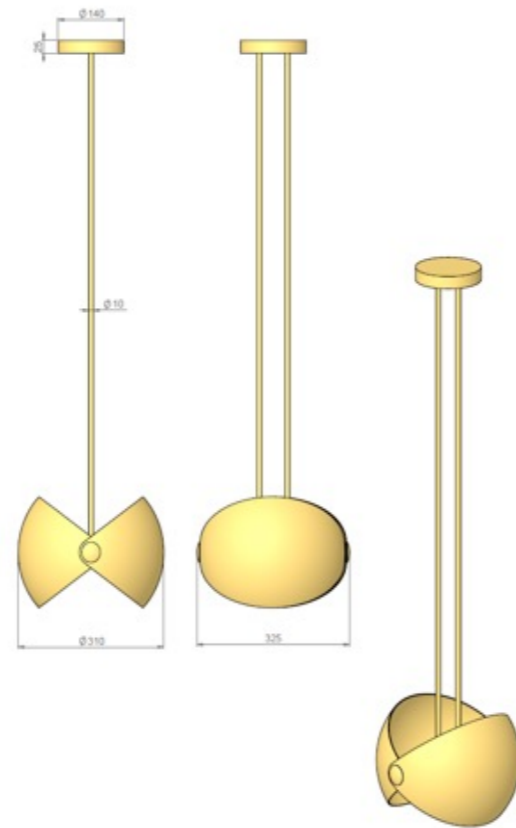
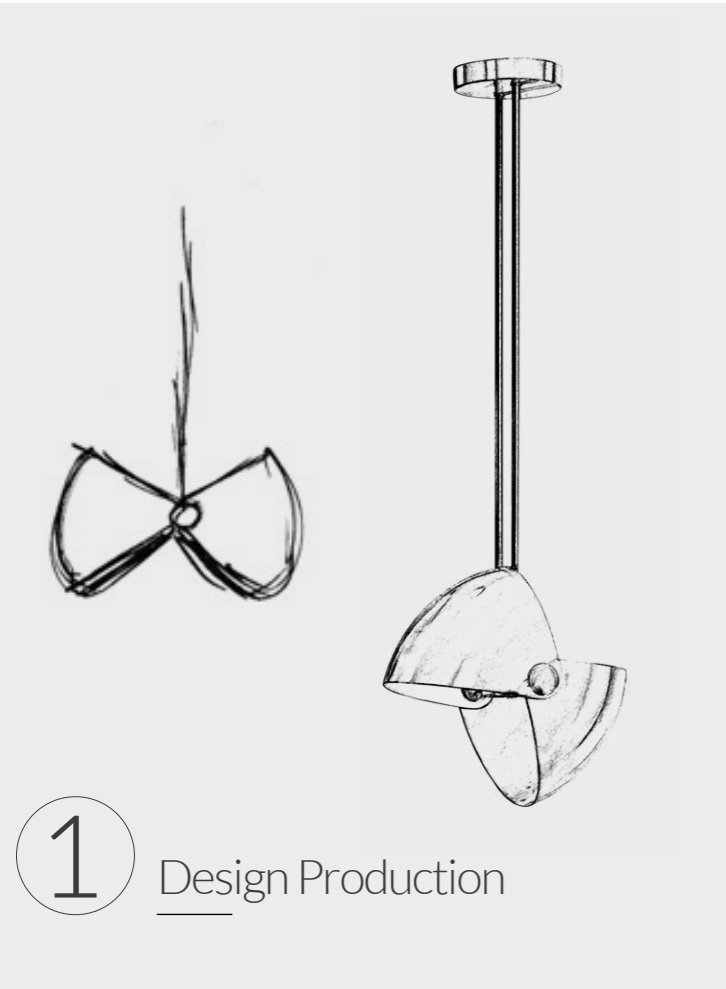

2 Technical support / Development



3 Prototyping / Finish

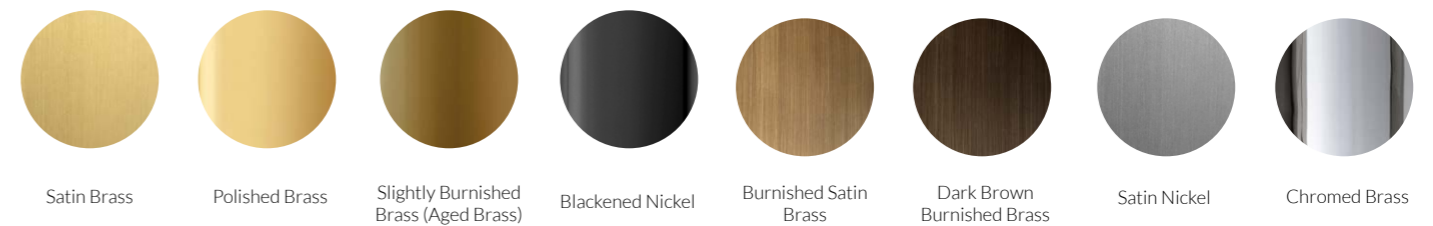

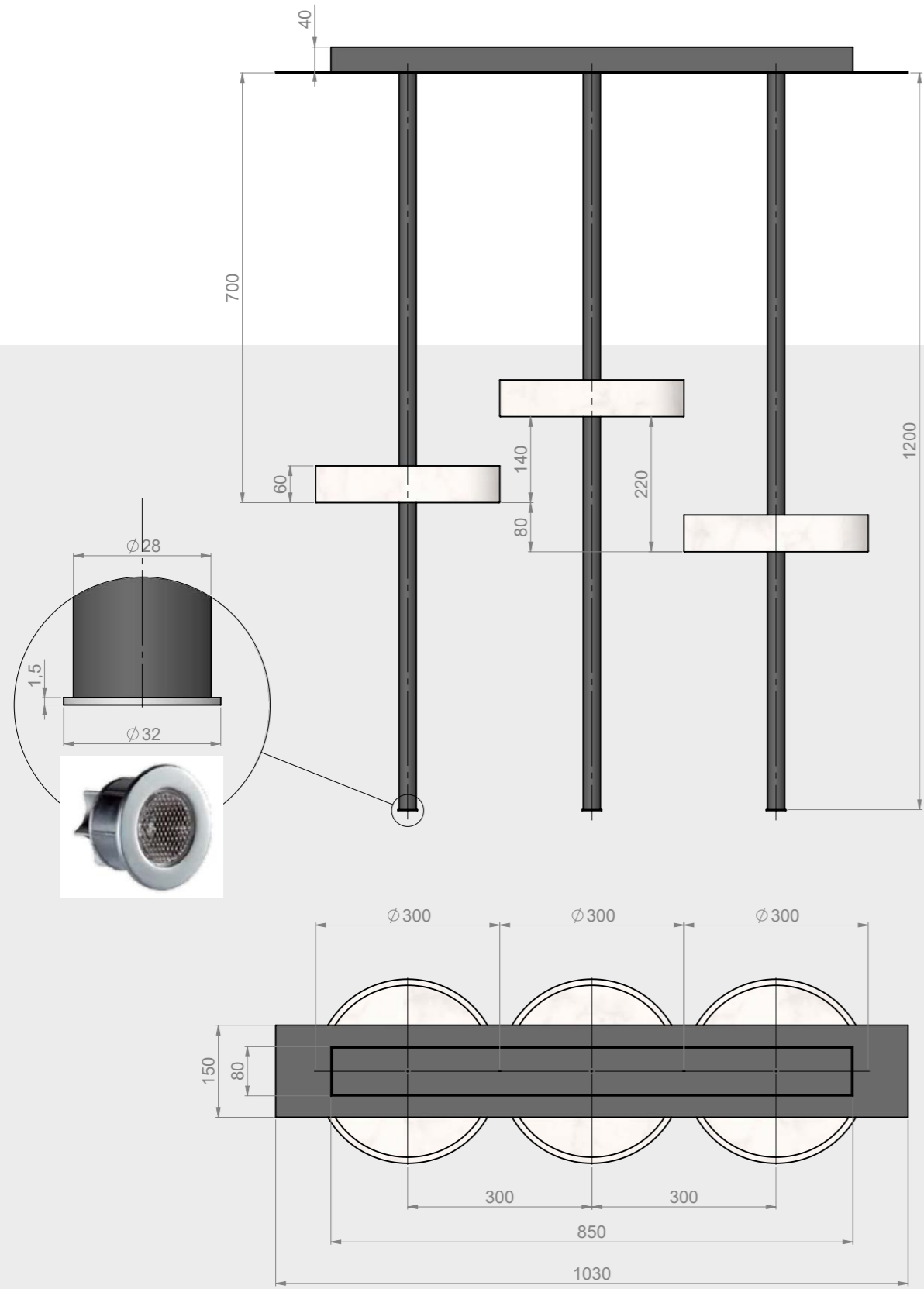

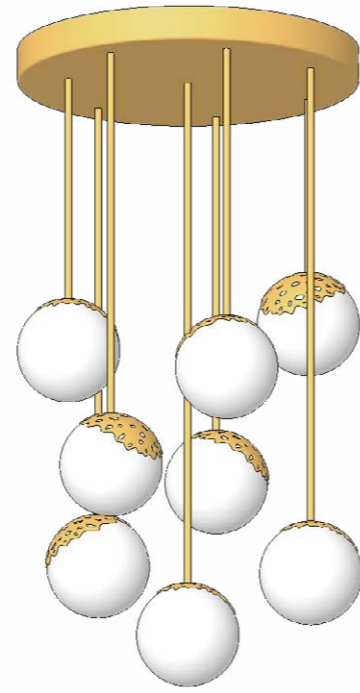

“A temple of light, since 1952.”



## GENERAL SALES TERMS AND CONDITIONS

---

Since 1952, Esperia has produced lamps of remarkable design quality, supplementing its collection with unique custom solutions while offering bespoke versions of its products to respond to a wide range of different tastes: please contact us to propose your projects and to verify their feasibility.

All certifications and dossiers can be requested directly from the company.

Esperia reserves the right to apply possible variations for the improvement of products.

Approval: received orders become binding only after our express written confirmation.

Consignment: the consignment of the goods is considered to have been effected at the moment of the shipment from our warehouses. The agreements with the shippers are always made in the name and on behalf of the client, who from this point forward acknowledges the completed status of the consignment.

The merchandise is shipped on behalf of the customer, and at the customer's risk.

Terms of consignment: approximately 30 days after order confirmation. The terms are indicative in nature; the seller is in no way liable or subject to claims for compensation or payment of damages in the event of delays in consignment, interruptions, partial or total suspensions of supply and shipment.

Claims: differences of hue cannot be considered as valid evidence for claims of defective materials. Any complaints regarding quality or type of materials must be communicated no later than 8 days after the date of delivery. Customers must make the items subject to complaints available for inspection to verify the described defects. In any case, the installation of the products exempts our company from any further responsibility.

Any discrepancies or defects in quality of the goods, when indicated in keeping with legal terms and accepted or acknowledged by the company, will be compensated only by replacement of the defective materials, following restitution of the defective merchandise.

The company is not liable for any claims of compensation for damages.

Measurements and colors: some of the materials we utilize are classified as natural products crafted by hand, and as such they may be subject to differences between the stated measurements and the measurements of the items effectively supplied. The company is not liable for any claims for compensation in this regard on the part of the customer.

Packing and quantities: the good condition of the packing and packaging, as well as the quantity of the goods consigned, is ratified by the acceptance of the goods on the part of the shipper. By signing the Transport Document, the shipper assumes responsibility for the proper condition of the goods and their quantities. Packing in wooden crates will be charged in the invoice.

Returns: customers cannot request replacement of goods for any reason without our express written authorization, and all the expenses involved will be covered by the customer.

Cancelations: no cancelation of orders will be accepted if the goods have already been produced or if the manufacturing has been initiated, or if the shipment has already been carried out.

In any case, order cancelation implies the obligation on the part of the customer to pay for the entire order. If acceptance of the cancelation is feasible, the customer is compulsorily required to reimburse all expenses incurred by the manufacturer prior to that moment.

Prices: the prices indicated in our listings do not include IVA (value-added tax), and cover consignment of the goods for shipment at our facilities in Poggibonsi.

Payments: Payments must be made in legal tender to our headquarters in Poggibonsi or by bank transfer as per our payment order, as agreed with the customer. A delay of over 10 (ten) days in payment, or lack of funds to cover a check or money order, constitutes payment default. In this case we reserve the right to suspend supply and to cancel any existing obligation on our part, demanding complete payment of our credit and taking legal action to obtain it, as well as payment of damages. In any case, when 10 days have passed without receipt of the required payment, we are thereby authorized to issue a sight draft with expenses, without preliminary notice. Furthermore, the unpaid debt will be subject to default interest calculated at the current standard rate.

### Thanks to:

Cristina Celestino

Cardini Home Design

Lukas Machnik Design

Lorenzo Borgia Ph.

Alessandro Bianchi Ph.

Mattia Balsamini Ph.





Esperia srl - Poggibonsi (Si) - Italia - tel. 0039(0577)936016  
[www.esperialuci.com](http://www.esperialuci.com) - [info@esperialuciarredamento.it](mailto:info@esperialuciarredamento.it)

