

MORELATO

E B A N I S T E R I A I T A L I A N A

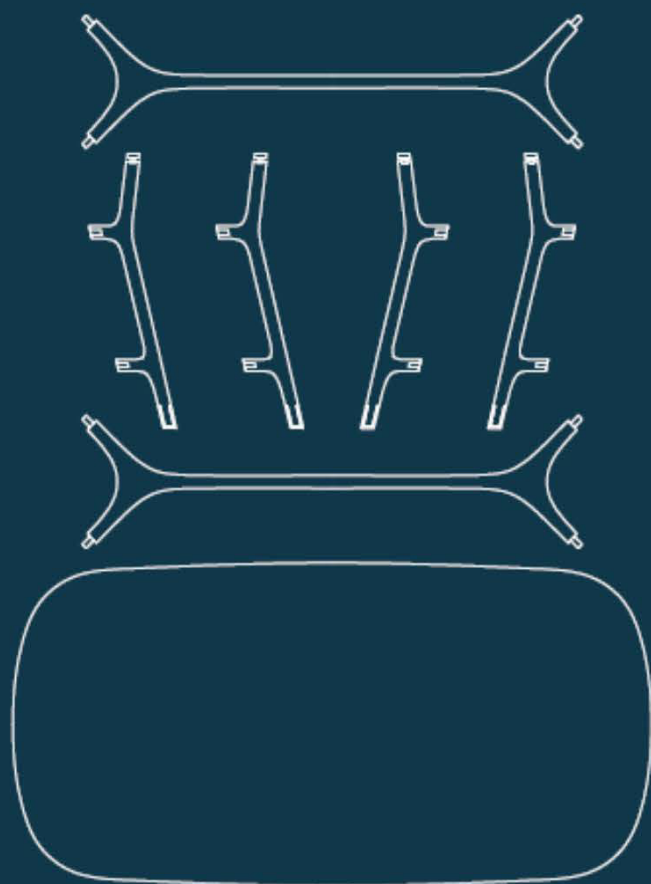

JOYCE COLLECTION

***“We were raised with the idea that  
if you want to make something  
you must know how to do it”***

***“Siamo cresciuti con l’idea che per  
creare bisogna saper fare”***

Famiglia Morelato

# BETWEEN HISTORICAL RESEARCH AND CLASSICS OF TOMORROW

---

## TRA RICERCA STORICA E CLASSICI DI DOMANI

This is the third generation of Morelato family specializing in fine woodcraft. We use precious woods in order to produce handcrafted iconic and functional furniture. The experience we gathered through the years, allows us to produce furniture redefining classicism in a unique contemporary way.

---

*Da tre generazioni siamo specializzati nell'arte dell'ebanisteria; produciamo con essenze pregiate mobili artigianali iconici e funzionali. La grande esperienza accumulata in decenni di produzione del mobile classico, oggi ci permette di realizzare arredi che reinventano la classicità ridefinendola in chiave moderna.*

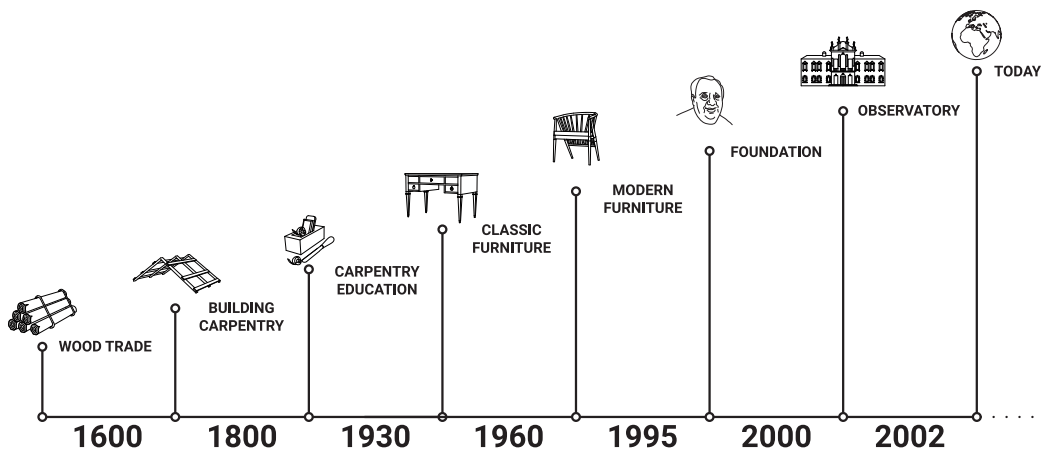



# THE JOYCE COLLECTION

---

## DESIGN BY LIBERO RUTILO

The Joyce collection is inspired by a combination of historical reminiscences and biomorphic shapes. Past and present, innovation and tradition blend into the fluid and natural shapes of these timeless objects. The whole collection is based on the value of fine woodworking issued from centuries of Italian craftsmanship shaping the beauty of solid wood and enhancing its natural characteristics. Elegant, sophisticated and versatile, the Joyce collection finds its place in a variety of environments, from classic to the most modern, everlasting all fashion styles.

---

*La collezione Joyce nasce da un connubio di reminiscenza storica e ispirazione biomorfica. Coniugano passato e presente, innovazione e tradizione cerca attraverso il segno fluido e naturale di plasmare degli oggetti progettati per durare nel tempo. Tutti i pezzi della collezione perseguono i valori di artigianalità e manualità tipici della tradizione ebanistica italiana esaltando la bellezza del legno massello sagomato, le forme e le sue caratteristiche naturali. Eleganti, sofisticati ma simultaneamente passe-partout e versatili, gli arredi della collezione Joyce, si adattano a diversi tipi di ambienti dai più classici ai più moderni resistendo al tempo e alle mode.*











# JOYCE DINING TABLE

---

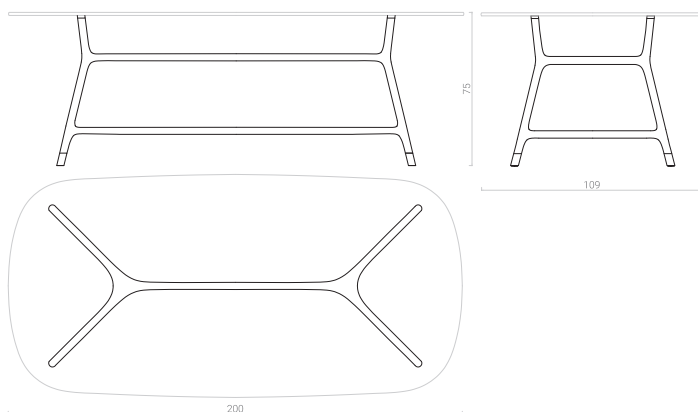

*Table made of turned ash wood with glass top and brass tips.*

---

Tavolo in legno di frassino con piano in vetro e particolari in ottone.

*Design: Libero Rutilo*





# JOYCE ROUND TABLE



*Table made of turned ash wood with glass top and brass tips.*

Tavolo in legno di frassino con piano in vetro e particolari in ottone.  
*Design: Libero Rutilo*

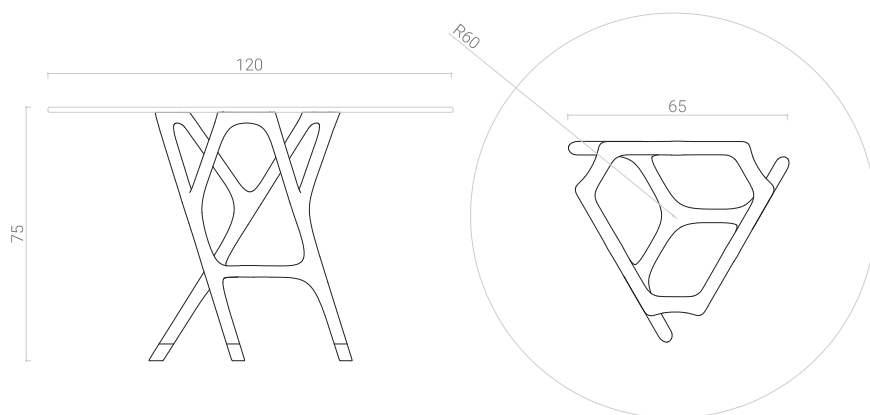



# JOYCE SIDEBOARD



*Sideboard made of ash wood with glass or marble top and brass handles.  
Two hinged doors and two sliding doors.*

*Credenza in legno di frassino con piano in vetro o pietra e maniglie in  
ottone. Due ante a battente e due ante scorrevoli.*

*Design: Libero Rutilo*

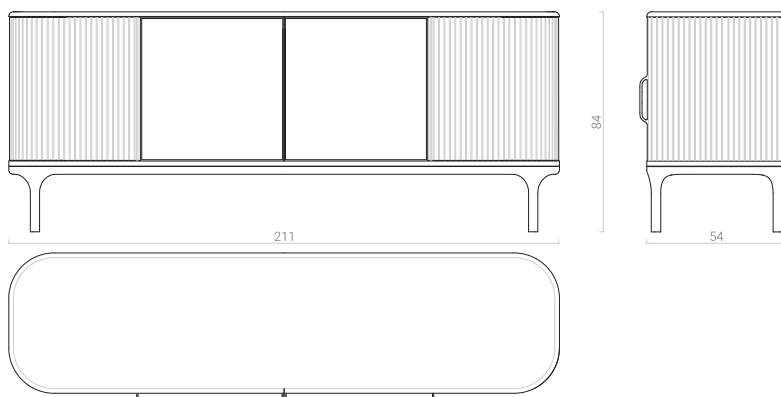



# JOYCE SIDEBOARD VIENNA STRAW

---

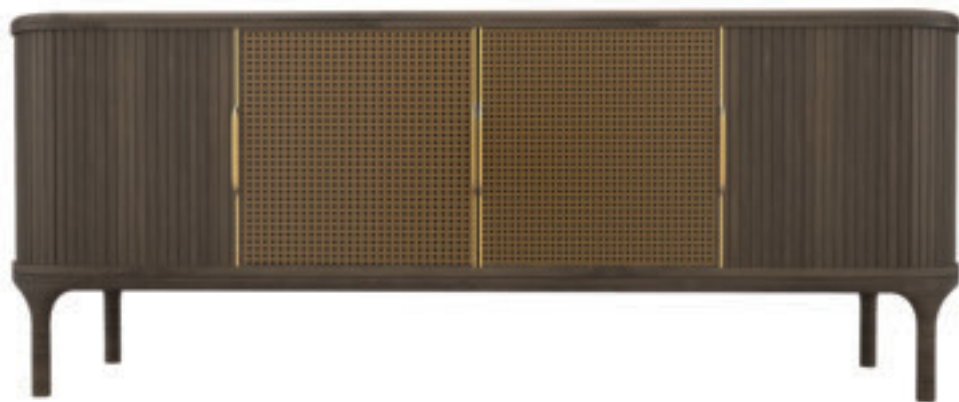

*Sideboard made of ash wood with glass or marble top and brass handles.  
Two hinged doors of woven straw and two sliding doors.*

---

*Credenza in legno di frassino con piano in vetro o pietra e maniglie in  
ottone. Due ante a battente in paglia di Vienna e due ante scorrevoli.*

*Design: Libero Rutilo*

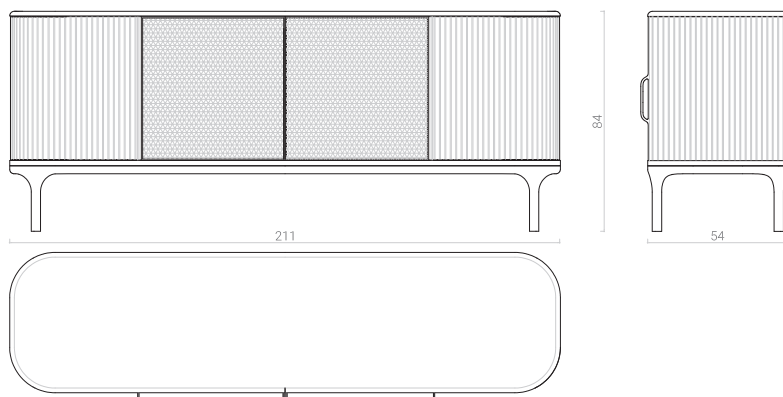



# JOYCE STOOL

---



*Bar stool made of turned ash wood with upholstered seat and brass tips.*

---

Sgabello bar in legno di frassino con seduta imbottita e puntali in ottone.  
*Design: Libero Rutilo*

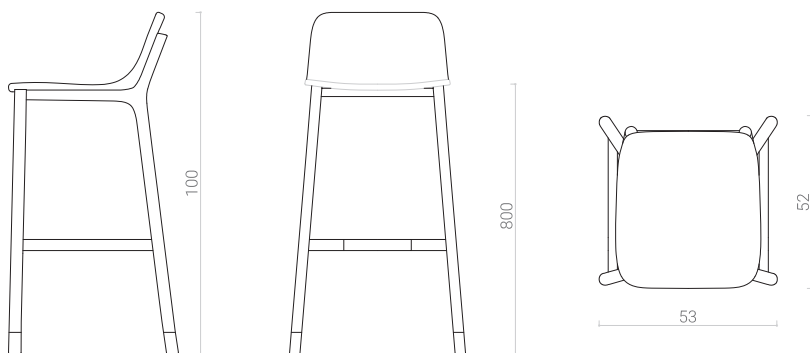



# JOYCE SMALL ARMCHAIR

---



*Armchair made of turned ash wood with upholstered seat and brass tips.*

---

Sedia con braccioli in legno di frassino con seduta imbottita e puntali in ottone.

*Design: Libero Rutilo*

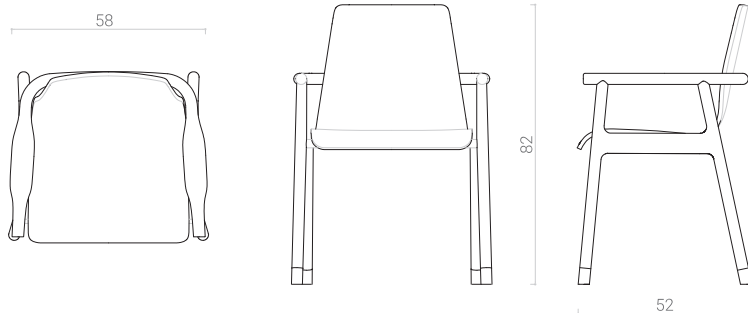



# JOYCE CHAIR

---



*Chair made of turned ash wood with upholstered seat and brass tips.*

---

Sedia in legno di frassino con seduta imbottita e puntali in ottone.

*Design: Libero Rutilo*

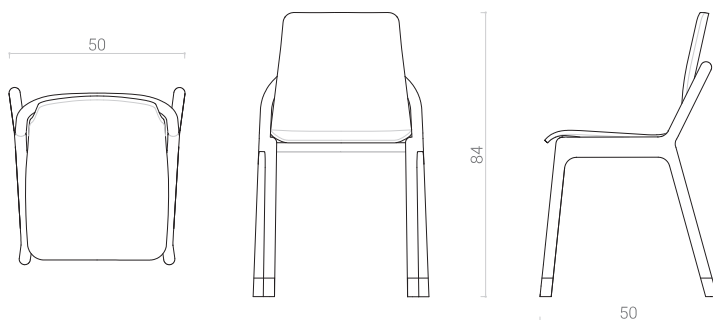















**MORELATO**

E B A N I S T E R I A I T A L I A N A

## **Morelato Srl**

Loc. Valmorsel, 540 – 37056 Salizzole -  
(Verona) ITALY

**Tel.:** (39) 045 695 40 01

**Fax.:** (39) 045 695 40 30

**morelato@morelato.it**

**[www.morelato.it](http://www.morelato.it)**

