

2024
Polttronova
Product Catalog

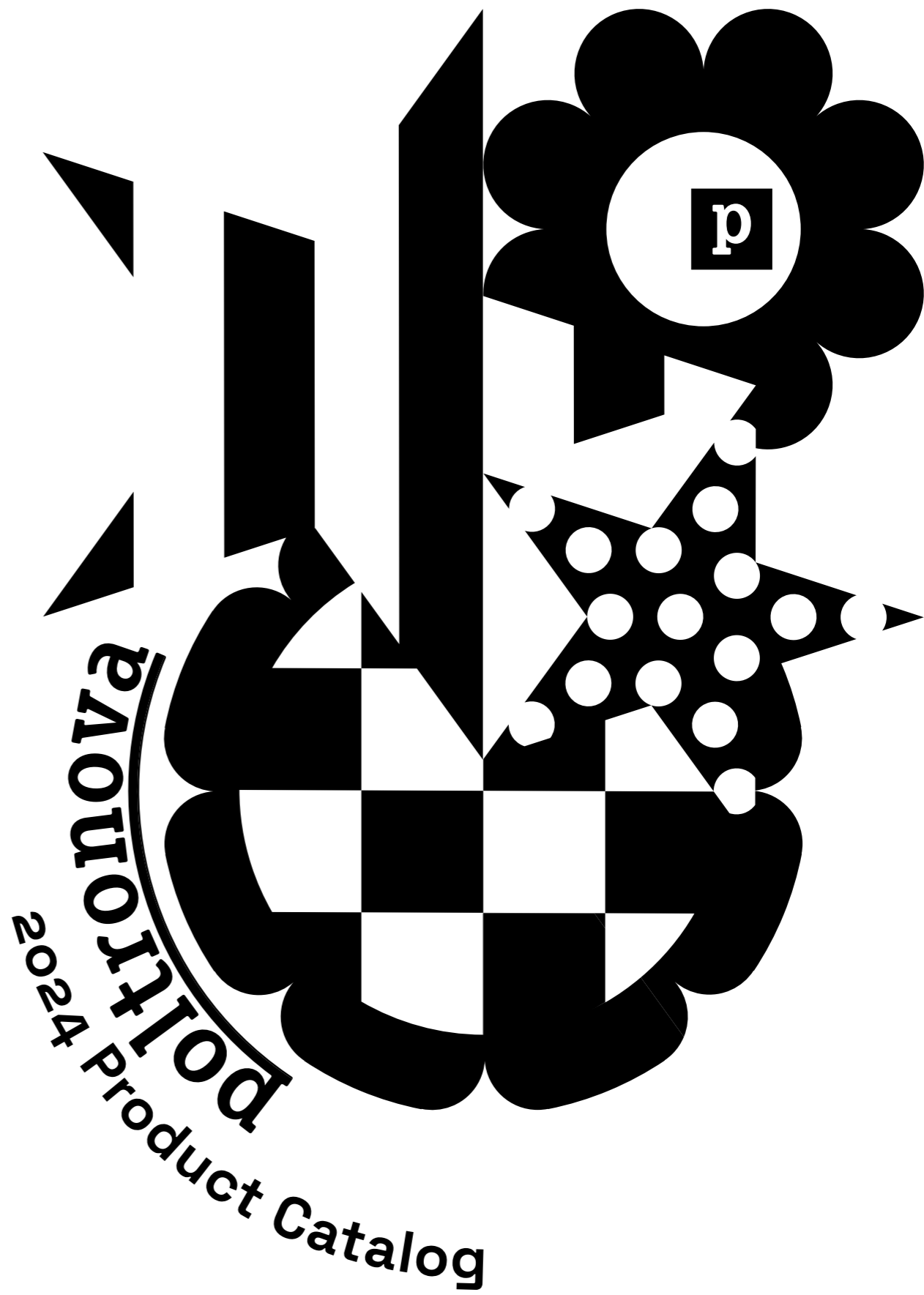

p

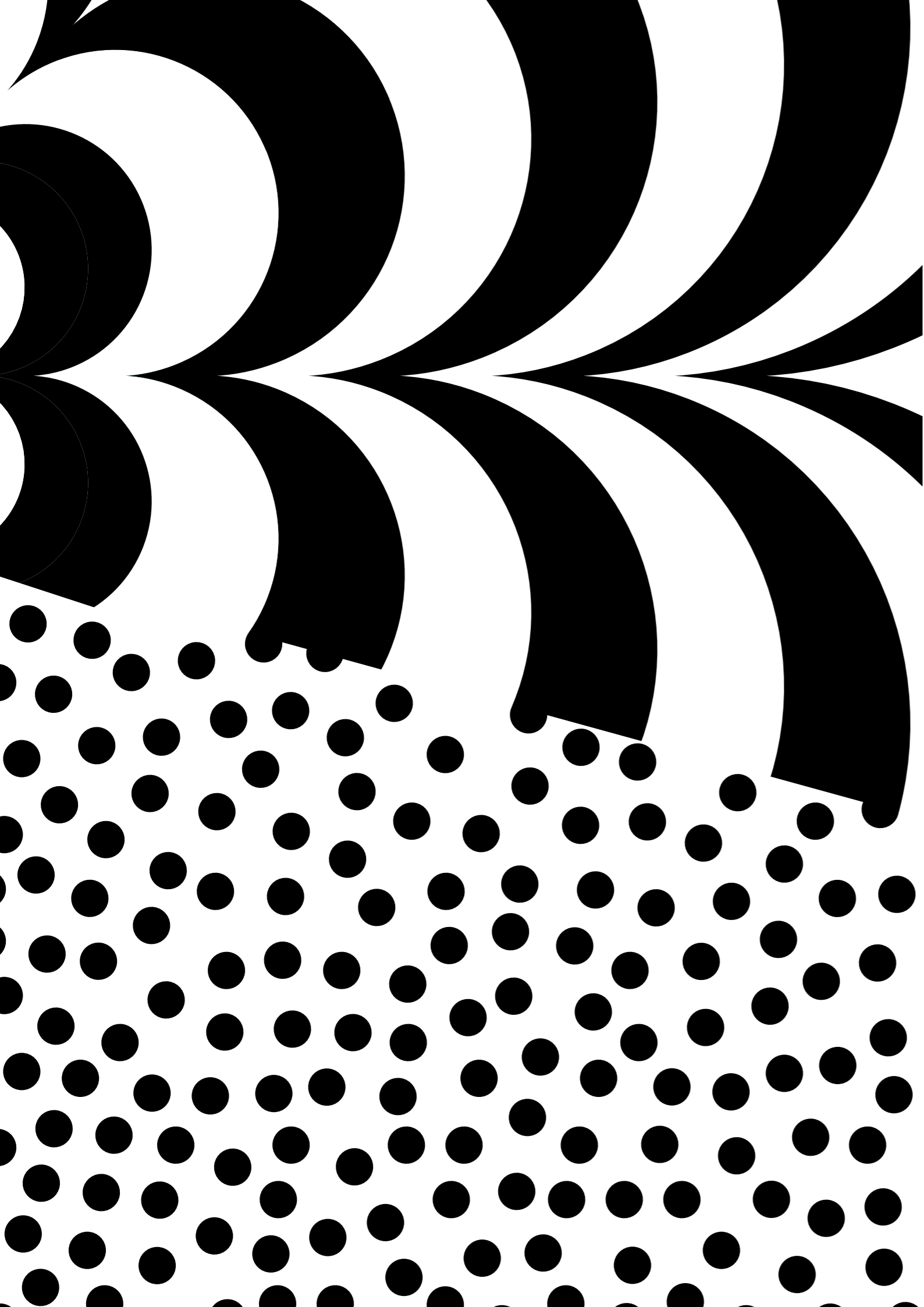

Poltronova è sinonimo di design non convenzionale. Fin dall'inizio [1957], il marchio italiano ha cercato collaborazioni con artisti e designer rivoluzionari, tra cui Archizoom, Superstudio, Vignelli, Aulenti, Ernst, Michelucci, DDL, Hollein, Coates e Arad.

Pur essendo un outsider, Poltronova ha infatti svolto un ruolo fondamentale in una rivoluzione epocale. Con sede nella provincia toscana, dove la produzione in serie di oggetti e mobili era pressoché sconosciuta, cavalca l'onda di ribellione che si sta diffondendo sulla scena stilistica internazionale.

Sotto la direzione artistica di Ettore Sottsass dal 1957 al 1972, Poltronova ha posto le basi per il postmodernismo applicato agli oggetti di uso quotidiano. Il risultato sono prodotti iconici come la poltrona Joe, la lampada/specchio Ultrafragola, il divano dinamico Superonda e la seduta Mies. E sebbene siano stati creati in un certo senso per gioco, tutti questi prodotti sono ancora in produzione come centrotavola singolari e insoliti per gli ambienti domestici. Oggi, sotto la guida devota e appassionata di Roberta Meloni, Poltronova continua ad essere uno dei marchi più prestigiosi del "Made in Italy", mantenendo viva la sua insolita identità fatta di fantastici oggetti realizzati artigianalmente con materiali di alta qualità.

Poltronova is synonymous with unconventional design. Right from the outset [1957], the Italian brand has sought out collaborations with revolutionary artists and designers, including Archizoom, Superstudio, Vignelli, Aulenti, Ernst, Michelucci, DDL, Hollein, Coates and Arad.

Despite being an outsider, Poltronova in fact played a key role in an epochal revolution. Based in provincial Tuscany, where the mass production of objects and furniture was virtually unknown, it rode the wave of rebellion that was breaking onto the international style scene.

Under Ettore Sottsass' artistic direction from 1957 to 1972, Poltronova laid the groundwork for postmodernism applied to objects for everyday use. The result was iconic products like the Joe armchair, the Ultrafragola lamp/mirror, the Superonda dynamic sofa and the Mies armchair. And although they were created in a certain sense for fun, all these products are still in production as singular and offbeat centrepieces for domestic settings. Today, under the dedicated and passionate leadership of Roberta Meloni, Poltronova continues to be one of the most prestigious "Made in Italy" brands, keeping alive its unusual identity made up of fantastic objects handcrafted from high quality materials.

Poltrone/Divani Armchairs/Sofas	Joe	8
	Joe Ball	18
	Mies	24
	Mitzi	32
	Plasma	38
	Rumble	46
	Safari	54
	Saratoga	62
	Sofo	70
	Superonda	78
Tessuti Fabrics	Farfalla	90
	Terrazzo	98
Lampade Lamps	Gherpe	108
	Passiflora	116
	Sanremo	124
	Ultrafragola	132
Appendiabiti Clothes-stands	Cessato Allarme	142
Panche Benchs	Canton	152
Tavoli Tables	Split	162
	To1	168
	To2	174
Portafoto/Specchi Photo holders/Mirrors	Ofelia, Spera, Vanitas	182
Tappeti Rugs	Autostrada	192
	Cielo / Farfalla / Prato	202
	Sofo	212
	Stella / Stellina	220
Designer Designers		228



Poltrone
Divani
Armchairs
Sofas

De Pas, D'Urbino, Lomazzi

Joe

Joe è una ampia e confortevole poltrona a forma di gigantesco guanto da baseball, montata su ruote invisibili. Con questo progetto i designer, ispirandosi alla poetica della Pop Art, materializzavano la loro ammirazione per il mitico campione del baseball americano Joe DiMaggio. Con un coraggioso cambio di scala hanno trasformato un guanto da baseball in un'accogliente poltrona, introducendo nell'ambiente domestico figurazioni iperrealistiche, appartenenti al mondo dell'arte.

Per celebrare il cinquantesimo anniversario della poltrona Joe progettata da Studio DDL, il Centro Studi Poltronova ha creato quattro edizioni speciali di un articolo imprescindibile che non è mai uscito dal catalogo. Joe Jeans è una versione elegante in denim di alta qualità il cui materiale rende omaggio all'immaginario popolare americano, dove è nata la cultura del baseball. Joe Plush, interamente rivestito in morbida pelliccia ecologica di alta qualità, aspira a diventare un giocattolo per l'arredamento d'interni, molto morbido e avvolgente, dedicato a tutti coloro che hanno un'anima sognatrice. Joe Whip è realizzato in pelle nera, una preziosa edizione con un intreccio elaborato che trasforma il bracciolo in una frangia e, per similitudine, in una frusta, preservando tutta la sua provocazione Pop. E infine, Joe Gold: anch'esso realizzato in pelle, naturalmente con una finitura scintillante, il costume da festa per un anniversario speciale.

Joe is a big comfortable chair in the form of a giant baseball glove, mounted on invisible wheels. With this project the designers, inspired by the poetics of Pop Art, gave material form to their admiration for the legendary American baseball star Joe DiMaggio. With a courageous shift of scale, they transformed the glove into a welcoming place to sit, inserting a hyperrealist figure borrowed from the world of art into the domestic environment.

To celebrate the fiftieth anniversary of the armchair Joe designed by DDL Studio, Centro Studi Poltronova has created four special editions for a must-have item which has never gone out of the catalogue. Joe Jeans is an elegant high quality denim version whose material pays homage to popular American imagination, where the culture of baseball was born. Joe Plush, entirely clad in high quality faux fur, aspires to becoming an interior decoration toy, very soft and embracing, and is dedicated to all those who have a dreamer's soul. Joe Whip is made of black leather, it is a precious edition with an elaborate braiding which transforms the thumb into a fringe, and by similitude, into a whip, preserving all its Pop provocation. And finally, Joe Gold: this too made of leather, of course with a sparkling finish, the party costume for a special anniversary.



Joe Jeans



Joe Gold



Joe Plush









Joe

Tipologia Typology	Poltrona Armchair						
Dimensioni Dimensions	175[l] x 122[p] x 95[a] cm 175[l] x 122[w] x 95[h] cm						
Materiali Materials	Struttura Structure	Metallo Metal					
	Imbottitura Padding	Poliuretano espanso preformato Preformed polyurethane foam					
	Rivestimento Covering	Joe	Pelle Leather				
		Joe Jeans	Denim in cotone e seta Cotton and silk denim				
		Joe Plush	Pelliccia ecologica Faux fur				
		Joe Gold	Pelle Leather				
		Joe Whip	Pelle Leather				
Colori Colors	Joe	NOR00105 	BAL99011 	NOR01038 	SOF00109 	BAL43003 	BAL93347
		VIN33090 	BAL33280 	RUS55063 	BAL93002 	VING3108 	BAL43001
		BAL53001 	VING1110 				
	Joe Jeans	Blu di Prussia Prussian blue 					
	Joe Plush	Rosa Taffy pink 	Grigio tortora Dove grey 	Carta da zucchero Baby blue 			
	Joe Gold	TRE54099 					
	Joe Whip	TIQ99001 					
Peso Weight	54 kg						

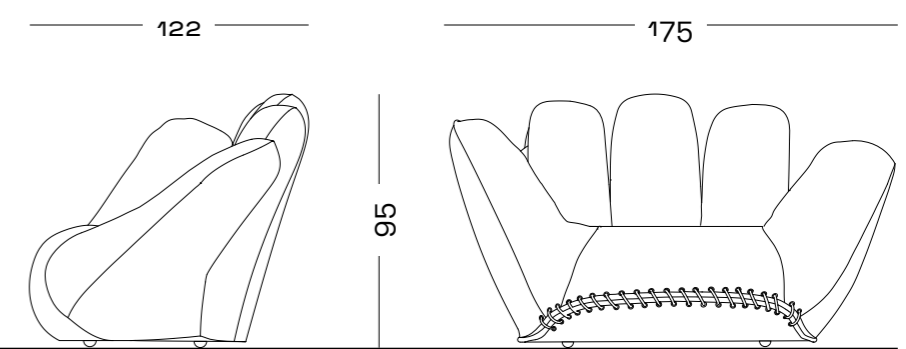

D'Urbino, Lomazzi

Joe Ball

In occasione del Cinquantesimo anniversario è stata realizzata Joe Ball, poggiapiedi e pouf in pelle, che si rifà nella forma e nelle cuciture alla classica pallina da baseball. Naturale completamento della poltrona, il pouf ha un peso al suo interno che lo rende stabile anche come seduta impedendogli di rotolare. Sulla pelle di Joe Ball sono impressi i caratteristici marchi del Centro Studi Poltronova, del cinquantesimo anniversario e del Joe.















For the fiftieth anniversary of Joe, was released Joe Ball, a leather footrest and pouf, whose shape and stitches are those of the classic baseball. A natural completion to the armchair, the pouf has a weight inside which also makes it steady as a seat, preventing it from rolling. Joe Ball's leather bears stamped the characteristic marks of Centro Studi Poltronova, of the fiftieth anniversary and of Joe.







Joe Ball

Tipologia Typology	Pouf/Poggiapiedi Pouf/Footrest				
Dimensioni Dimensions	Ø 55 cm				
Materiali Materials	Imbottitura Padding	Poliuretano preformato Preformed polyurethane			
	Bilanciamento Balancing	Peso posizionato internamente Weight placed internally			
	Rivestimento Covering	Pelle Leather			
Colori Colors	NORo0105 	BAL99011 	NORo1038 	SOFoo0109 	BAL43003 
	BAL93347 	VIN33090 	BAL33280 	RUS55063 	BAL93002 
	VIN93108 	BAL43001 	BAL53001 	VIN91110 	TRE54099 
Peso Weight	8 kg				

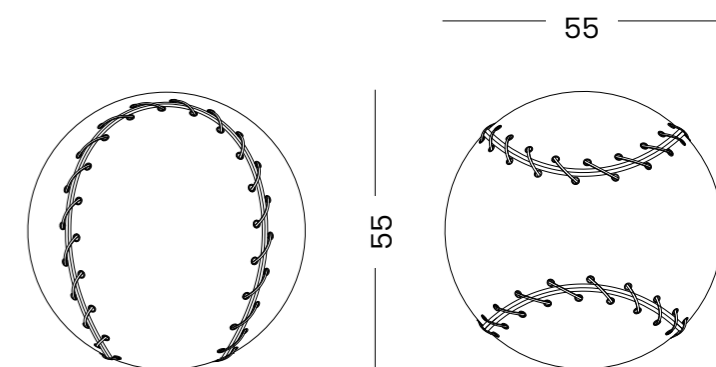

Mies

La poltrona Mies nasce nel 1969 dall'idea di impiegare una striscia di para o caucciù, materiali resistenti ed elastici, come seduta. La struttura, un triangolo in metallo cromato, evidenzia la purezza della sagoma. Il cuscino del poggiatesta e della lampada-poggiapiedi sono in cavallino. Il nome evidenzia l'analogia della sua struttura con i progetti di Mies van der Rohe e rende omaggio al grande maestro deceduto nel medesimo anno. Nella sua rigorosa geometria la poltrona Mies sintetizza la filosofia degli Archizoom Associati, componenti di punta del Movimento Radicale Italiano, nato attorno alla secondo metà degli anni Sessanta.

The Mies armchair was born in 1969 from the idea of using a strip of para rubber or India rubber –strong, elastic materials– as a seat. The structure, a triangle in chrome-plated metal, brings out the purity of the silhouette. The headrest and footrest-lamp cushions are in ponyskin. The name emphasizes the similarity of the structure to the projects of Mies van der Rohe, as a tribute to the great master who died that same year. With its rigorous geometric design, the Mies armchair sums up the philosophy of Archizoom Associati, leading figures of the Italian Radical movement starting in the second half of the 1960s.







9

10

11

12

13

14

aspes

aspes

aspes

TECHNICAL



Mies

Tipologia Typology	Poltrona e Poggiapiedi Armchair and Footrest	
Dimensioni Dimensions	Poltrona Armchair	131[l] x 74[p] x 80[a] cm 131[l] x 74[w] x 80[h] cm
	Poggiapiedi Footrest	105[l] x 20[p] x 36[a] cm 105[l] x 20[w] x 36[h] cm
Materiali Materials	Telaio Frame	Metallo cromato Chrome-plated metal
	Seduta Seat	Lastra in gomma naturale che si deforma in risposta al peso del corpo Natural rubber sheet that deforms in response to the weight of the body
	Poggiatesta/Poggiapiedi Headrest/Footrest	Cavallino Ponyskin
Lampadine Bulbs	3 x LED E14 3W [max] 3000K	
Peso Weight	Poltrona Armchair	18 kg
	Poggiapiedi Footrest	10 kg

Poggiapiedi
Footrest

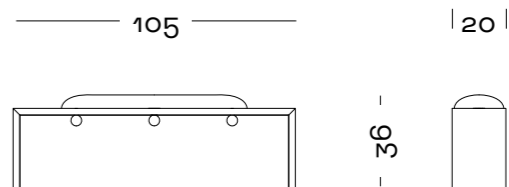

Poltrona
Armchair

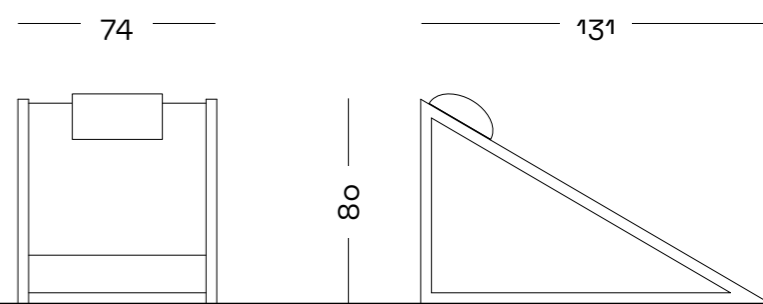

Mitzi

Hans Hollein

Il divano Mitzi, parte della ricca produzione dal maestro austriaco Hans Hollein dedicata al design, evidenzia uno schema rigoroso di progetto accanto alla messa in scena di una dialettica tra connotazioni e simbologie differenti. L'elemento morbido e quello rigido sono compresenti nei materiali e nelle forme. Cuscini imbottiti e soffice panno di lana stanno insieme al legno e alla foglia di radica della struttura, coesistono anche la linea curva dello schienale con quella retta alla base, una sorta di maschile e femminile riuniti insieme. Mitzi è un divano con un nome di donna.

The Mitzi sofa, part of the rich production of the Austrian master Hans Hollein, highlights a rigorous design while staging of a dialectic between different connotations and symbolisms. Soft and rigid elements are present together in the materials and forms. Upholstered cushions and soft wool cloth come alongside the walnut, both solid and in sheets, of the structure, and the curved line of the backrest coexists with the straight line at the base, masculine and feminine together: a sofa with a woman's name.







Mitzi

Tipologia Typology	Divano Sofa	
Dimensioni Dimensions	205[l] x 93[p] x 100[a] cm 205[l] x 93[w] x 100[h] cm	
Materiali Materials	Struttura Structure	Metallo Metal
	Base Base	Compensato di pioppo con finitura in acero, vernice all'acqua semi-lucida Poplar plywood with erable finish, semi-gloss water-based varnish
	Imbottitura Padding	Poliuretano Polyurethane
	Rivestimento Upholstery	Tessuto in lana nero, rosso e bianco Black, red and white wool fabric
Peso Weight	70 kg	

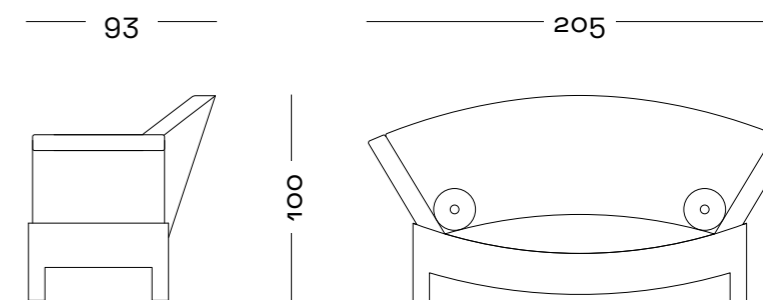

Nigel Coates

Plasma

Nell'ambito del crescente interesse di Nigel Coates per i prodotti d'arredo, la poltrona Plasma esprime la vocazione del progettista inglese a disegnare forme essenziali mediante la progettazione digitale. Costituita da un set di cuscini, in varia tonalità di colore, sospesi su un esile struttura in metallo dalle curve armoniche, Plasma unisce la semplicità di un segno grafico continuo alla complessa tecnologia della struttura, realizzata con metodi di piegatura e saldatura computerizzata. Dotata di poggiatesta è disponibile anche per esterno.













In the context of Nigel Coates' growing interest in furniture, the Plasma armchair reflects the English designer's taste for designing essential forms by digital means. Composed of a set of cushions in different tones placed on a slender metal structure with harmonious curves, Plasma combines the simplicity of a continuous graphic sign with the complex technology of the structure, made with computerized methods of bending and welding. With a footrest, it is also available for outdoor use.



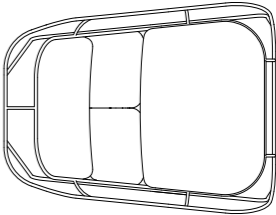
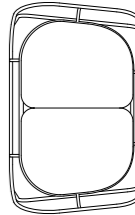
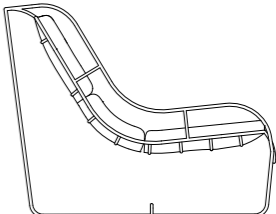

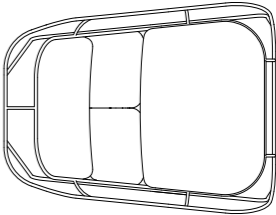
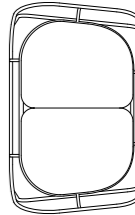
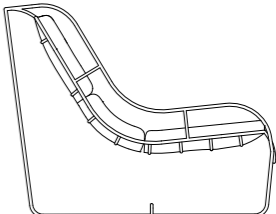

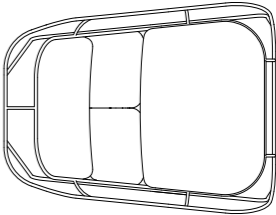
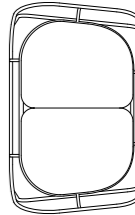
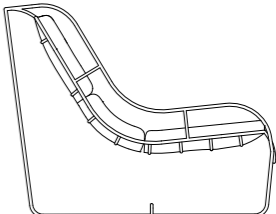

Tipologia Typology	Poltrona e Poggiapiedi Armchair and Footrest																
Dimensioni Dimensions	Poltrona Armchair	85[l] x 108[p] x 84[a] cm 85[l] x 108[w] x 84[h] cm															
	Poggiapiedi Footrest	85[l] x 54[p] x 44[a] cm 85[l] x 54[w] x 44[h] cm															
Materiali Materials	Telaio Frame	Metallo verniciato a polvere Powder-coated metal															
	Cuscini Cushions	Imbottitura in poliuretano Tessuto in poliammide ed elastam + Strato intermedio in poliuretano Polyurethane padding Polyamide and elastane fabric + Polyurethane midlayer															
Colori Colors	Disponibile in sei diverse combinazioni di tre colori suggerite dal designer. Possibile personalizzare la propria combinazione di colori [la scheda dei colori è disponibile sul nostro sito web: www.poltronova.it/Plasma/colori] Available in six different three-colors combinations suggested by the designer. A custom color combination is also possible [color chart available on our website: www.poltronova.it/Plasma/colors]																
	Grigio tortora Dove grey 	Giallo limonata Lemonade yellow 	Verde militare Army green 														
	Rosa plaisir Plaisir pink 	Grigio basalto Basalt grey 	Arancio clementina Clementine orange 														
Peso Weight	Poltrona Armchair	22 kg															
	Poggiapiedi Footrest	11 kg															
		<table border="0"> <tr> <td></td> <td style="text-align: center;">Poltrona Armchair</td> <td style="text-align: center;">Poggiapiedi Footrest</td> </tr> <tr> <td style="text-align: center;">85</td> <td style="text-align: center;"></td> <td style="text-align: center;"></td> </tr> <tr> <td></td> <td style="text-align: center;">108</td> <td style="text-align: center;">54</td> </tr> <tr> <td style="text-align: center;">84</td> <td style="text-align: center;"></td> <td style="text-align: center;"></td> </tr> <tr> <td></td> <td style="text-align: center;">44</td> <td></td> </tr> </table>		Poltrona Armchair	Poggiapiedi Footrest	85				108	54	84				44	
	Poltrona Armchair	Poggiapiedi Footrest															
85																	
	108	54															
84																	
	44																

Gianni Pettena

Rumble

Il design di questo divano deriva dall'esperienza di vivere in un luogo ampio, originariamente un atelier ottocentesco per artisti, in cui i mobili dovevano essere pensati nella scala del luogo e non nella scala dell'uomo. È un oggetto che dialoga con il volume dello spazio complessivo e che tiene conto del fatto che è lì che viene usato. Il divano è una forma semplice, originaria, un grembo dove tutto accade o è già accaduto, ma che suggerisce ancora delle possibilità, altre cose che vi possono accadere. È un oggetto che fa corrispondere alla scomposizione della forma quella della funzione, acquista significato quando la geometria pulita dello status quo iniziale viene stravolta da funzioni altrettanto sgrammaticate.

The design of this sofa derives from the experience of living in a large place, originally a 19th century atelier for artists, where the furniture had to be conceived on the scale of the place and not on a human scale. It is an object that dialogues with the volume of the overall space and takes into account the fact that that is where it is used. The sofa is a simple, original form, a womb where everything happens or has already happened, but which still suggests possibilities, other things that can happen there. It is an object that breaks up form as it breaks up function; it acquires meaning when the clean geometry of the initial status quo is upset by equally ungrammatical functions.









Rumble

Tipologia Divano
Typology Sofa

Dimensioni 248[l] x 248[p] x 51[a] cm
Dimensions 248[l] x 248[w] x 51[h] cm

Materiali **Struttura** **Legno massello verniciato color argento**
Materials **Frame** Solid wood painted silver

Cuscini **Schiuma poliuretanic**
Cushions Polyurethane foam

Rivestimento **Panno Casentino**
Covering Casentino wool

Colori **Rosa** **Verde** **Blu**
Colors Pink Green Blue



Peso 143 kg
Weight

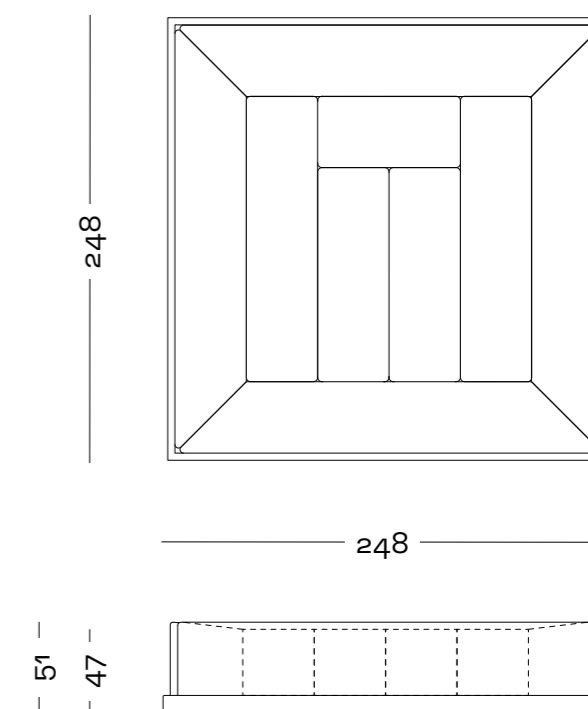

Archizoom Associati

Safari

Il divano Safari è una seduta multipla con il profilo dello schienale configurato in una serie di onde, nel vuoto centrale, cui si accede mediante un varco, ci si raccoglie come in una sorta di rito tribale. Il mobile è composto da quattro pezzi di due diversi tipi [due moduli poltrona e due moduli divanetto]. Il divano Safari viene messo in produzione per la prima volta da Poltronova nel 1968. Per la struttura viene utilizzata la tecnica sperimentale del fibreglass. Per il rivestimento di seduta e schienale gli Archizoom scelgono un tessuto animalier stampato con motivo a macchia di leopardo. Lo stesso motivo viene utilizzato per il tappeto in poliuretano espanso collocato in mezzo alle sedute. La scelta dell'animalier leopardo aveva un richiamo colto nell'opera "Bedroom ensemble" [1963] di Claes Oldenburg, maestro della Pop Art, e della sua successiva "Leopard chair", ma anche a un gusto Kitsch adottato dal gruppo in polemica con la necessità del far conseguire la forma dalla funzione. È parte della collezione permanente di prestigiose istituzioni museali tra cui il Centre Pompidou e il Museo di Belle Arti di Montréal. Ha preso parte a numerose esposizioni.

The Safari sofa is a multiple seat with the profile of the backrest shaped like a series of waves, one gathers in the central void, accessed through an opening, as in a sort of tribal ritual. The piece of furniture consists of four pieces of two different types [two armchair modules and two sofa modules]. The Safari sofa was put into production for the first time by Poltronova in 1968. The experimental fibreglass technique was used for the structure. For the seat and backrest upholstery, Archizoom chose a printed animal pattern fabric with a Leopard print. The same pattern is used for the polyurethane foam rug placed between the seats. The choice of the leopard pattern was a cultured reference to the work "Bedroom ensemble" [1963] by Claes Oldenburg, master of Pop Art, and his subsequent "Leopard chair" [1963], but also to a Kitsch taste adopted by the group in polemic with the need to make form follow function. It is part of the permanent collection of prestigious museums including the Centre Pompidou and the Museum of Fine Arts in Montreal. It has taken part in numerous exhibitions.













Safari

Tipologia Typology	Divano Sofa		
Dimensioni Dimensions	85/130[l] x 85/130[p] x 64[a] cm 85/130[l] x 85/130[w] x 64[h] cm		
Materiali Materials	Struttura Frame	Vetroresina Fibreglass	
	Imbottitura Padding	Schiuma poliuretana Polyurethane foam	
	Rivestimento Covering	Pelliccia sintetica con motivo a macchie di leopardo Faux fur with leopard animal pattern	
Tappeto Rug	Schiuma poliuretana rivestita in pelliccia sintetica con motivo a macchie di leopardo Polyurethane foam covered in faux fur with leopard animal pattern		
Colori Colors	Struttura Frame	Bianco White 	Nero Black 
	Rivestimento Covering	Grigio Grey 	Giallo Yellow 
Peso Weight	Configurazione 2 poltrone + 2 divani Configuration 2 armchairs + 2 sofas	159,5 kg	
	Modulo poltrona Armchair module	29 kg	
	Modulo divano Sofa module	49 kg	
	Tappeto Rug	3,5 kg	

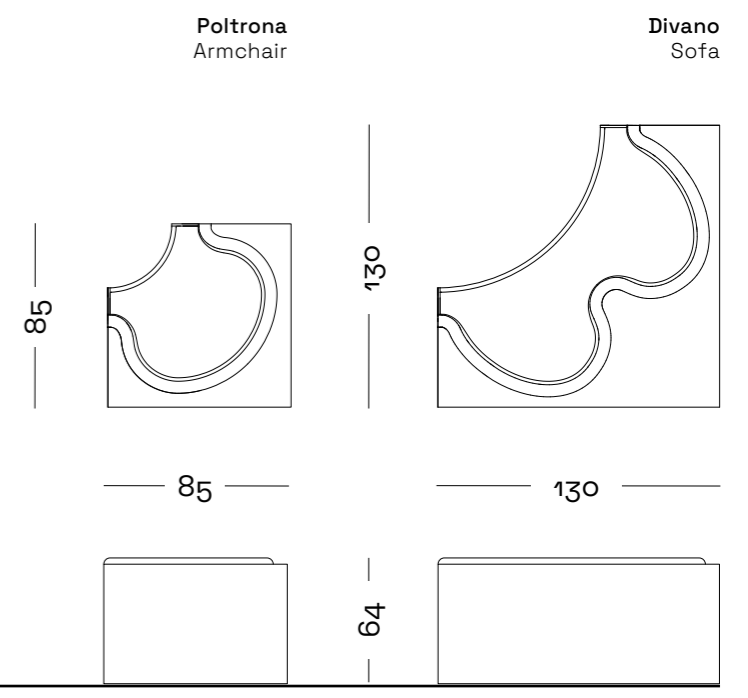

Lella and Massimo Vignelli

Saratoga

La serie è composta di poltrona e divano a due, tre e quattro posti. La struttura rigida, realizzata mediante assemblaggio di quattro elementi di uguale spessore, con angoli smussati, accoglie cuscini di seduta leggermente sporgenti. La voluta purezza della sagoma è accentuata dalla preziosità delle finiture: una laccatura della scocca al poliestere lucido, simile a quella dei pianoforti e la pelle pregiata dei morbidi cuscini, analoga al rivestimento delle auto extra lusso. L'essenzialità della forma, abbinata alla precisione del disegno e alla raffinatezza di finiture e dettagli, rende il design di Lella e Massimo Vignelli, intramontabile, al di sopra delle mode epocali, che hanno sempre avversato.

The series is composed of an armchair and sofas with two, three or four seats. The rigid structure, made by assembling four parts of equal thickness, with rounded edges, contains slightly protruding seat cushions. The desired purity of the silhouette is accentuated by the precious finishes: glossy polyester lacquer for the chassis, similar to that of a pianoforte, and the fine leather of the soft cushions, resembling the upholstery in luxury automobiles. The essential form combined with the precision of the design and the refinement of the finishes and details make this project by Lella and Massimo Vignelli timeless, over and above passing fashions, which they always avoided.





**DON'T
SHOOT
THE
PIANIST**



esperti, testimoni, impazienti, cinici, indifferenti, cattivi, inventori, fenomeni, amici, fanciulli, parucchiati,
 lemmici, inappetenti, fanatici, melomani, esauriti, cani...



4 foto 2.-€



Saratoga

Tipologia Typology	Poltrona, Divani a due, tre, quattro posti, Tavolino Armchair, two, three, four-seater Sofas, Coffee table	
Dimensioni Dimensions	Poltrona e Divani Armchair and Sofas	90/150/210/270[l] x 90[p] x 60[a] cm 90/150/210/270[l] x 90[w] x 60[h] cm
	Tavolino Coffee table	90[l] x 90[p] x 20[a] cm 90[l] x 90[w] x 20[h] cm

Materiali Materials	Struttura Frame	Legno rifinito con una vernice al poliestere altamente riflettente Wood finished in highly reflective polyester lacquer	
	Cuscini Cushions	Imbottitura in piuma e poliuretano, rivestimento in pelle Feather and polyurethane padding, leather cover	

Colori Colors	Struttura Frame	Bianco White	Nero Black				
	Cuscini Cushions	Rivestimento in pelle disponibile in 4 differenti colori suggeriti dagli autori Leather covering available in 4 different colors suggested by the authors					
		BAL99011	NOR01038	SOF00109	BAL53001		
		Possibilità di personalizzare le sedute scegliendo tra le altre nostre pelli a disposizione Also possible to choose other variants among our leather color chart					
		NOR00105	BAL43003	BAL93347	VIN33090	BAL33280	RUS55063
		BAL93002	VIN93108	BAL43001	VIN91110	TRE54099	

Peso Weight	Poltrona Armchair	58,5 kg	Divani Sofas	83/110/134 kg	Tavolino Coffee Table	28 kg
-----------------------	-----------------------------	----------------	------------------------	----------------------	---------------------------------	--------------

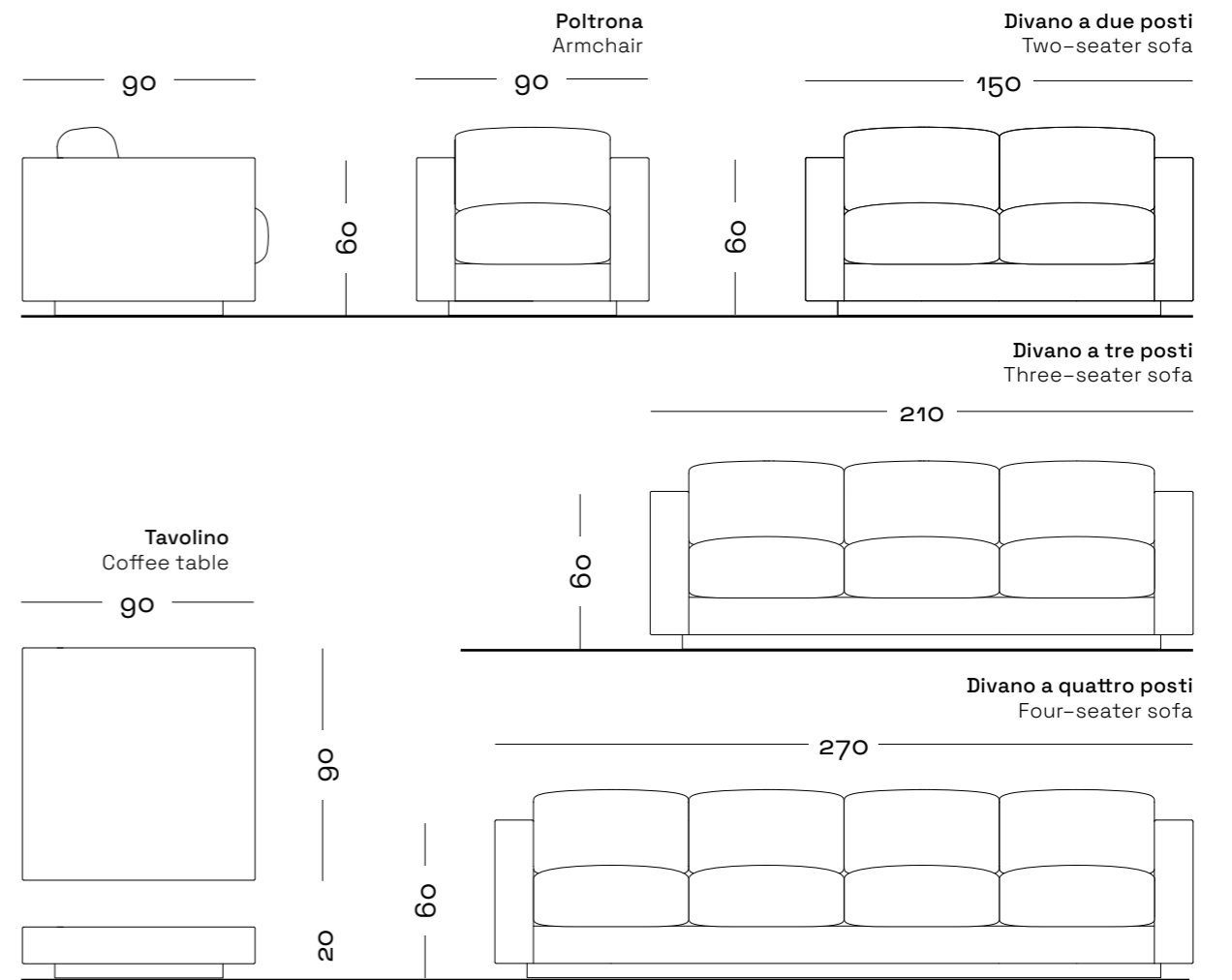

Sofo

Superstudio

Sofo è una seduta da mettere in fila, come un treno, o da sovrapporre per costruire solide montagne colorate. È solo un blocco, ricavato mediante un taglio a "S", da un cubo di poliuretano, rivestito con un tessuto solcato da due grandi righe. È il risultato di una operazione molto semplice, senza spreco, né di materiale, né di pensiero. Si presenta come un oggetto compatto, astratto e colorato, che trasmette gioia di vivere, come le cose che arrivano da un altro mondo.

Sofo is a seat to place in a row, like a train, or to stack to build solid, colorful mountains. It is simply a block made with an S-shaped cut from a cube of polyurethane, covered with fabric featuring two large stripes.

The result of a very simple operation, without wasted material or thought. It presents itself as a compact, abstract, colorful object that communicates the joy of living, like things that arrive from another world.









Sofo

Tipologia Typology	Poltrona e Divano Armchair and Sofa	
Dimensioni Dimensions	Poltrona Armchair	82[l] x 82[p] x 74[a] cm 82[l] x 82[w] x 74[h] cm
	Divano Sofa	164[l] x 82[p] x 74[a] cm 164[l] x 82[w] x 74[h] cm
Materiali Materials	Struttura Frame	Poliuretano Polyurethane
	Base Base	Plastica termoformata Vacuum-formed plastic
Rivestimento Covering	Tessuto in cotone, poliestere e viscosa Cotton, polyester and viscose fabric	
Colori Colors	Verosa [Verde e Rosa] [Green and Pink]	Rosancio [Rosa e Arancio] [Pink and Orange]
Peso Weight	Poltrona Armchair	12 kg
	Divano Sofa	24 kg

Poltrona
Armchair

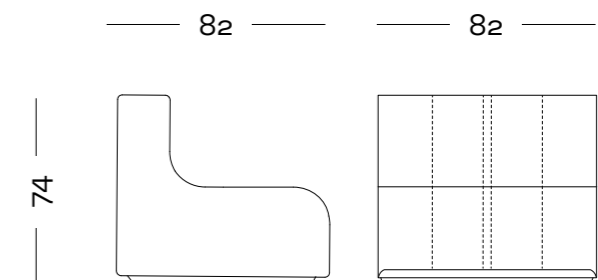

Divano
Sofa

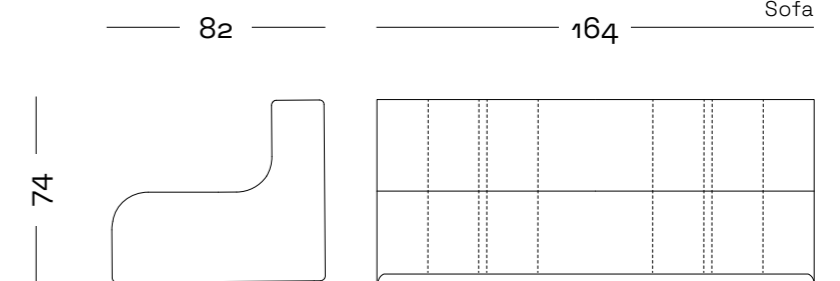

Archizoom Associati

Superonda

Disegnato nel 1967 dal gruppo radicale fiorentino Archizoom, è il primo divano privo di scocca. È costituito da due onde, ricavate da un blocco di poliuretano tagliato in due parti da un taglio a "S", che s'incastrano e si sovrappongono, modellando differenti configurazioni. Leggerezza e componibilità consentono di variarne l'uso: Superonda può essere divano, letto e chaise longue. Come molti dei pezzi disegnati dal gruppo Archizoom, si rivela una sfida alle convenzioni borghesi, stimolando la creatività e la fantasia dell'utente. Il rivestimento in sky lucido, nei colori primari bianco, nero e rosso, accentua la sua immagine pop.

Nel 2017 Poltronova rende omaggio a Superonda – pezzo iconico di anti-design che conserva intatta la sua natura scandalosamente giocosa – invitando tutti i membri del team Radical a disegnare un nuovo outfit celebrativo per le sei Superonda in edizione limitata: Pois di Cristina Morozzi per Massimo Morozzi / No-Stop di Gilberto Corretti / Spots di Paolo Deganello / Stripes di Andrea Branzi / Dressing di Dario Bartolini per Lucia Bartolini / Babele Decoded di Dario Bartolini.

Designed in 1967 by the Florentine Radical group Archizoom, this was the first sofa without a conventional frame. It is composed of two waves made from a polyurethane block cut into two parts with an S-shaped incision, which can be interlocked and stacked to produce different configurations. The lightness and modular design permit a range of various uses: Superonda can be a sofa, a bed or a chaise longue. Like many of the pieces designed by the Archizoom group, it challenges bourgeois conventions, stimulating the creativity and fantasy of the user. The shiny leatherette cover in the basic colors of white, black and red accentuates the pop image.

In 2017 Poltronova pays tribute to Superonda – an anti-design iconic piece of furniture that fully preserves its outrageously playful nature – by calling on all members of the Radical team to design a new, celebrative outfit for the six Superonda limited edition: Pois by Cristina Morozzi per Massimo Morozzi / No-Stop by Gilberto Corretti / Spots by Paolo Deganello / Stripes by Andrea Branzi / Dressing by Dario Bartolini per Lucia Bartolini / Babele Decoded by Dario Bartolini.



80



Pois



No-Stop



Spots



Stripes

Dressing

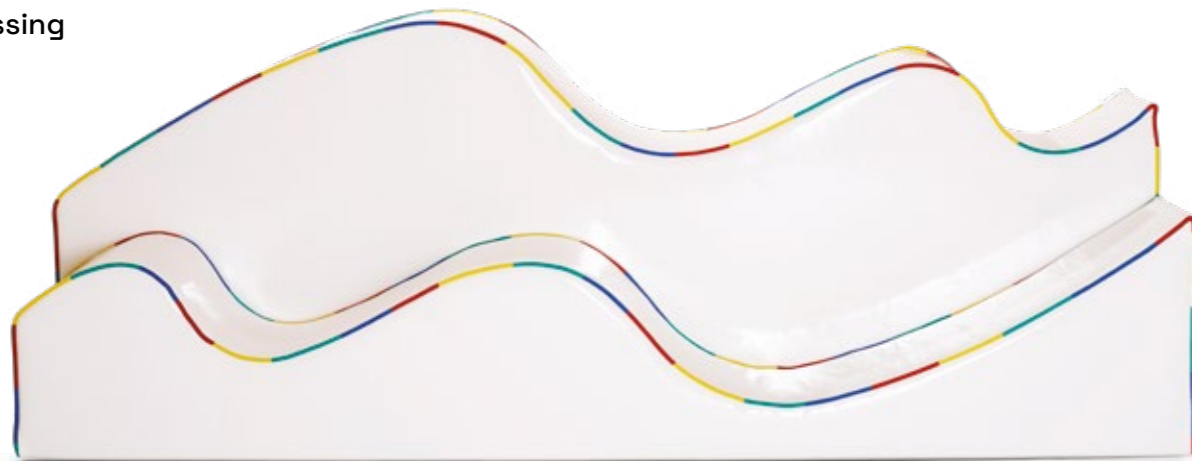

Babele Decoded

















Superonda

Tipologia Typology	Divano dinamico Dynamic sofa			
Dimensioni Dimensions	240[l] x 36[p] x 100[a] cm 240[l] x 36[w] x 100[h] cm			
Materiali Materials	Struttura Frame	Ottenuta da un taglio di un blocco di poliuretano Cut from a block of polyurethane		
	Rivestimento Covering	Classic, Dressing	Tessuto spalmato in PVC lucido Shiny PVC coated fabric	
Colori Colors		Pois, No-Stop, Spots, Stripes, Babele Decoded	Tessuto spalmato in PVC opaco stampato Printed matte PVC coated fabric	
	Classic	Bianco White	Rosso Red	Nero Black
				
	Pois	Magenta su rosa Magenta polka dots on pink		
				
	No-Stop	Pattern bianco su nero White pattern on black		
				
	Spots	Macchie gialle e nere su grigio beige Yellow and black patches on greige		
				
Stripes	Righe arancio su verde muschio Orange stripes on moss green			
				
Dressing	Passamaneria giallo, blu, rosso e verde su bianco Yellow, blue, red and green trimmings on white			
				
Babele Decoded	Simboli multicolore su bianco Multicolor symbols on white			
				
Peso Weight	34 kg			

— 36 —

— 240 —

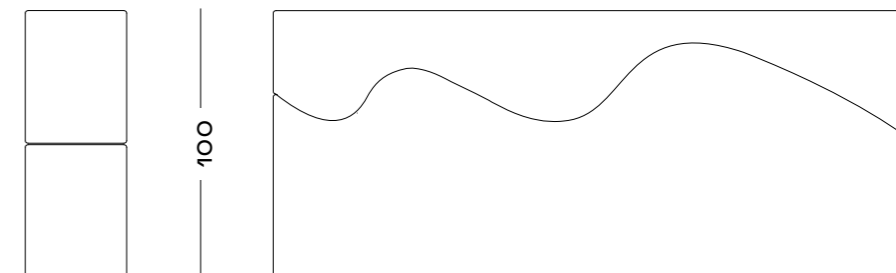

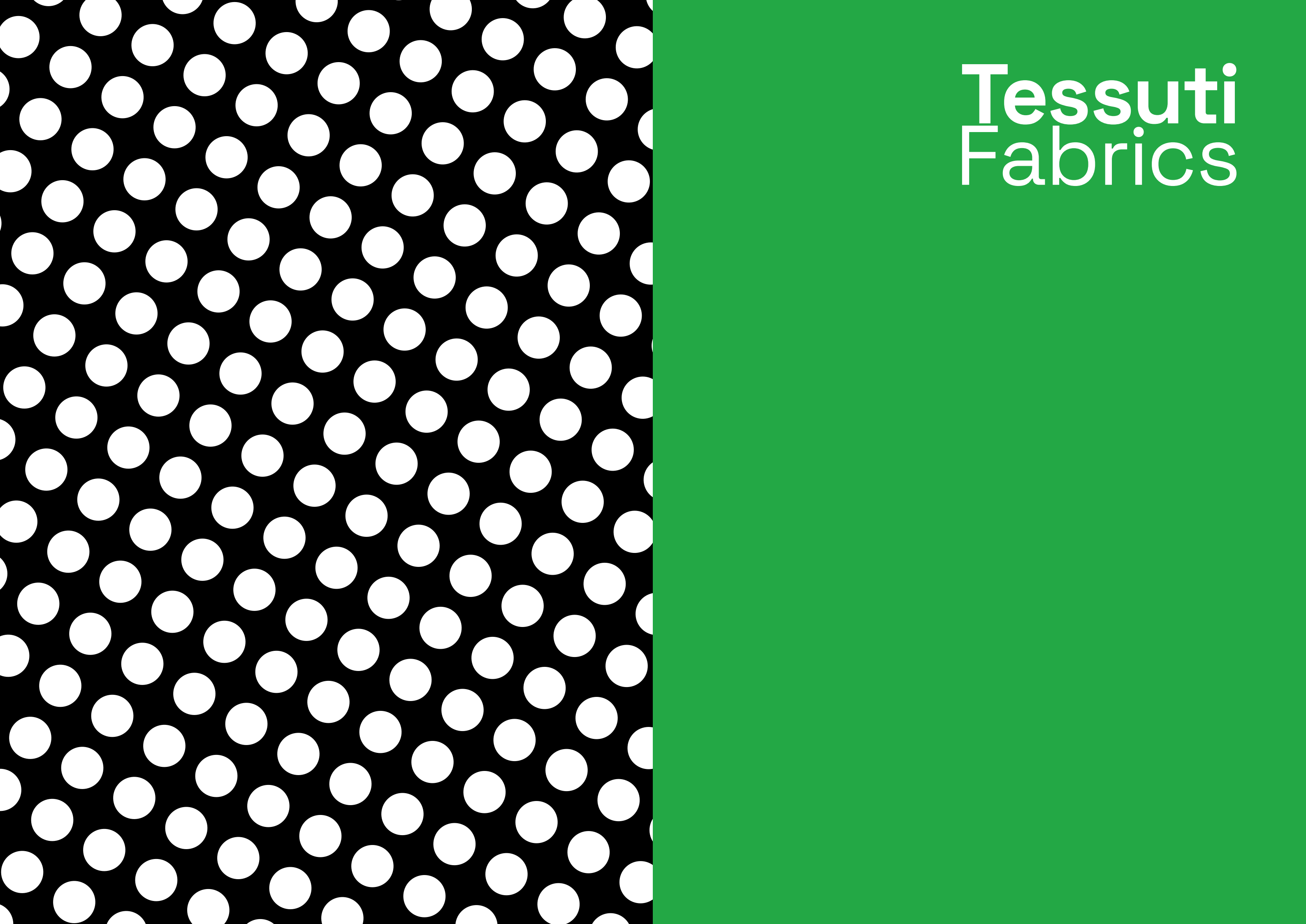

Tessuti Fabrics

Archizoom Associati

Farfalla

In the Farfalla the anti-system art of American artists such as Lichtenstein and, more generally, of Pop Art continues to develop. The Farfalla pattern, designed by Archizoom in 1968, was a reinterpretation in an acid, pop key of the floral theme that came from a much more composed tradition, and is now part of Poltronova's nascent fabric catalogue.

«I have no idea how come, but I remember very well the reason why Massimo and I designed the fabric "Le farfalle", [The Butterflies], by Poltronova... The idea was to make decorations with flowers, but crossed with pop decorations, like Lichtenstein's, that imitated printers' designs, creating [in our intent] a contrast between the floral theme and the "pop" theme... In reality, the result was a lively fabric but not as acid as we expected; the "Over-the-Top Generation" of Archizoom was not yet mature...»

[Andrea Branzi, 2022]

Nella Farfalla continua a svilupparsi l'arte antisistema che fu degli artisti americani come Lichtenstein e più in generale della Pop Art. Il pattern Farfalla, disegnato da Archizoom nel 1968, era rivisitazione in chiave acida e pop del tema floreale che veniva da una tradizione assai più composta, rientra ora a far parte del nascente catalogo tessuti Poltronova.

«Non so per quale motivo ma ricordo molto bene il motivo per cui con Massimo abbiamo progettato il tessuto "Le farfalle" della Poltronova... L'idea era quella di fare dei decori con fiori, ma incrociato con dei decori pop, come quelli di Lichtenstein, che imitavano i disegni tipografici, creando [nel nostro intento] il contrasto tra il tema floreale e il tema "pop"... In realtà ne è venuto fuori un tessuto vivace ma non così acido come noi pensavamo; la "Generazione esagerata" degli Archizoom non era ancora matura...»

[Andrea Branzi, 2022]









Tipologia
Typology

Tessuto stampato
Printed fabric

Materiali
Materials

Tessuto in poliammide ed elastam + Strato intermedio in poliuretano
Polyamide and elastane fabric + Polyurethane midlayer

Farfalla

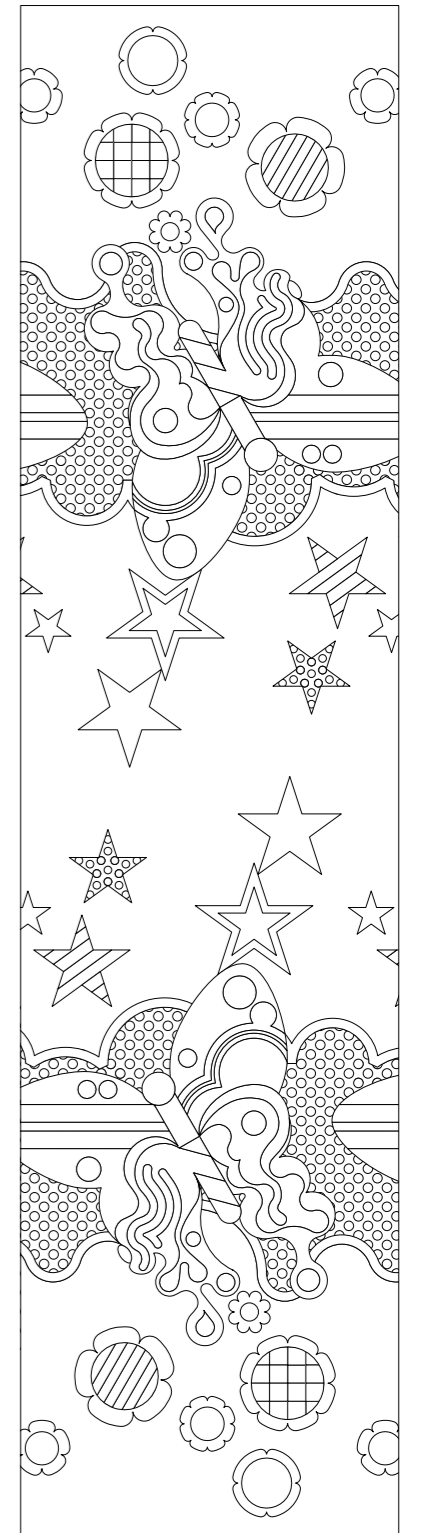

Bethan Laura Wood

Terrazzo

Il periodo durante il quale Bethan Laura Wood ha vissuto a Venezia ha indubbiamente avuto un effetto a lungo termine su di lei e sulla sua produzione. Nel 2010, durante la sua partecipazione a una residenza all'interno di uno splendido palazzo veneziano, Bethan si è innamorata del terrazzo che ricopriva ogni centimetro di quello spazio, catturata dalla molteplicità di pattern, e da quel momento il suo lavoro ne è stato influenzato. Le pietre preziose si liberano così dal terrazzo, dal paesaggio impresso negli occhi, per incastonarsi nel tessuto disegnato per Poltrona e regalare, utilizzato come rivestimento dei prodotti, un'altra originale idea di relax e un'esperienza indimenticabile.

Bethan Laura Wood's experience in a Venetian palazzo, during an artists' residency in 2010, is translated into a kaleidoscopic pattern, with many colored "gems" to support the lightness of the wave. Bethan fell madly in love with the terrazzo that covered every inch of the space at her disposal, and fascinated by the many types of decoration, she has proposed them again in her works. The precious stones are thus released from the terrace, from the landscape imprinted in the eye, to set themselves in the fabric designed for Poltrona and, used as a covering for the products, give another original idea of relaxation and an unforgettable experience of their own.









Tipologia
Typology

Tessuto stampato
Printed fabric

Materiali
Materials

Tessuto in poliammide ed elastam + Strato intermedio in poliuretano
Polyamide and elastane fabric + Polyurethane midlayer

Colori
Colors

Verde
Green

Rosa
Pink



Terrazzo



Lampade Lamps

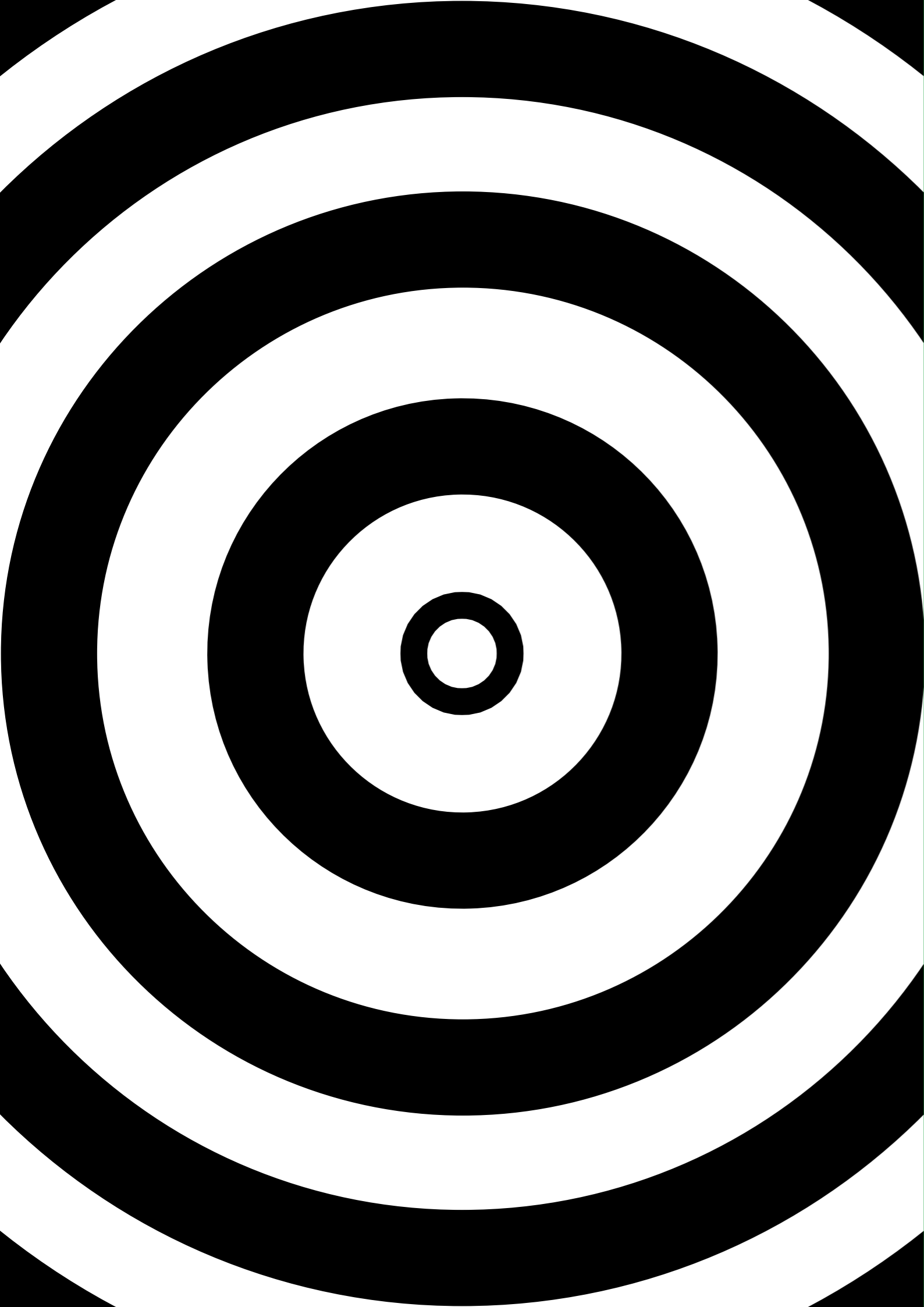

Superstudio

Gherpe

La lampada Gherpe non appartiene alle tradizionali tipologie di apparecchi d'illuminazione da tavolo, sia per la sua forma, simile al guscio di una creatura marina, sia per i materiali di uso industriale, quali il metacrilato. Rappresenta uno dei primi esempi di corpo illuminante interattivo che, grazie alla relazione con l'utente, è in grado di cambiare le tonalità: dalla luce bianca per illuminare a quella colorata per trasformare la percezione emotiva di un ambiente.

The Gherpe table lamp does not belong to the traditional typologies of lighting fixtures placed on a surface, due to its form like the shell of a marine creature, and to its use of an industrial material like methacrylate.

It represents one of the first examples of an interactive luminous object, which thanks to its relationship with the user is capable of changing its tone: from white light for illumination, to colored light to alter the emotional perception of a space.

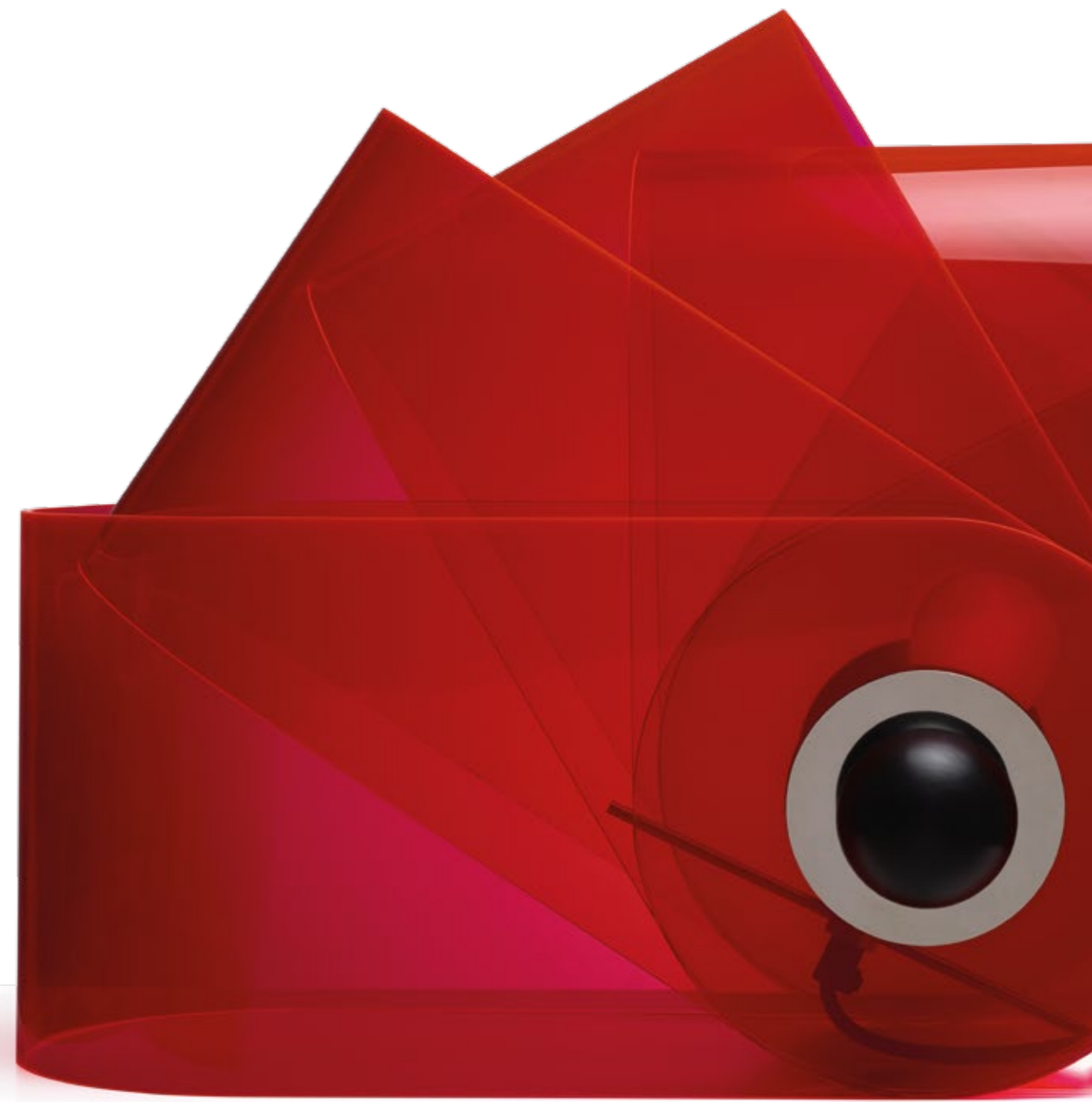

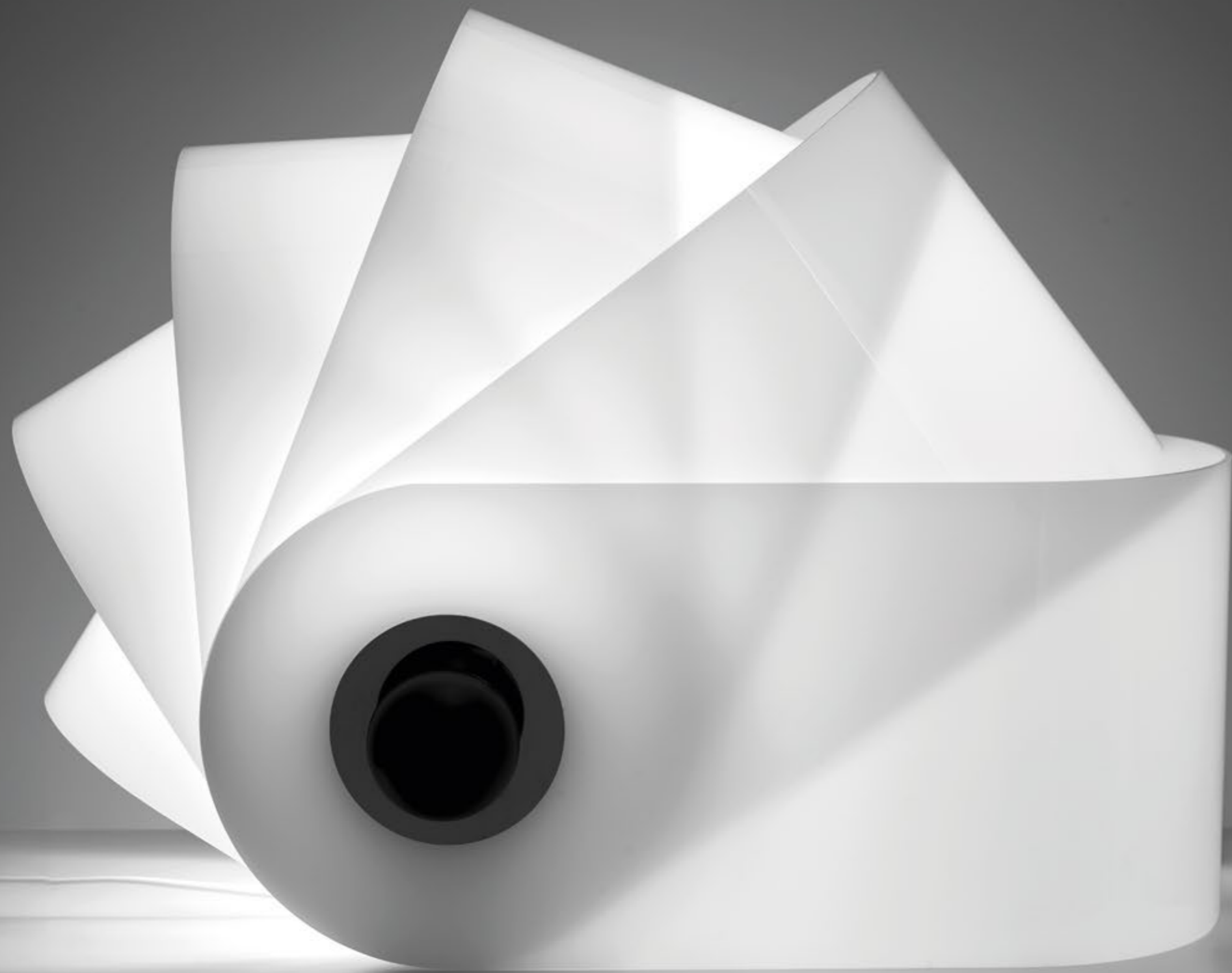



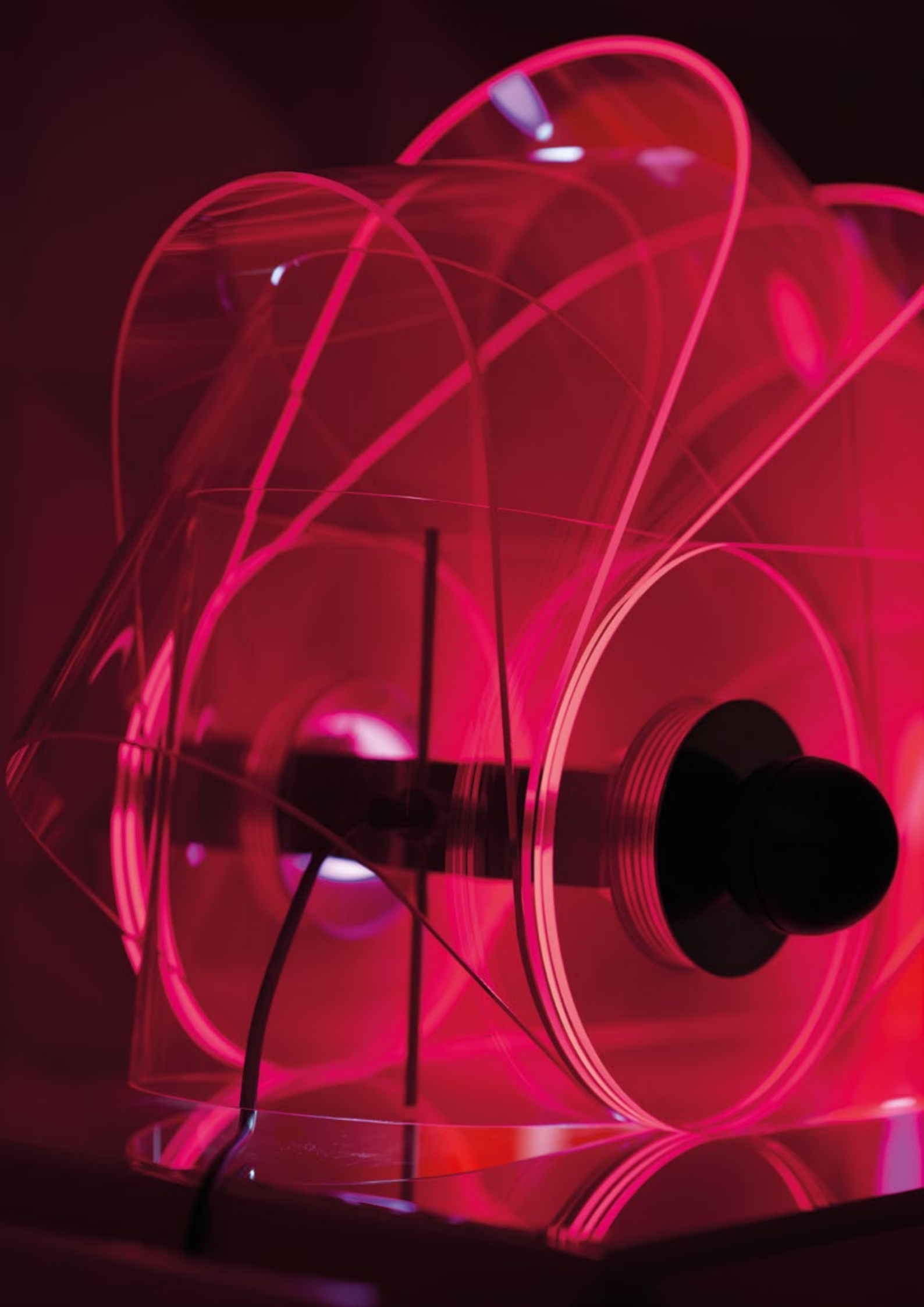

Gherpe

Tipologia Lampada da tavolo
Typology Table lamp

Dimensioni 53[l] x 31[p] x 38[a] cm
Dimensions 53[l] x 31[w] x 38[h] cm

Materiali Diffusori **PMMA termoformato**
Materials Diffusers Heat-formed PMMA

Piastre e raccordi **Acciaio lucidato a specchio**
Plates and fittings Polished steel

Manopole **Nylon tornito**
Knobs Turned nylon

Lampadina 1 x LED A60 E27 10W [max] 6400K
Bulb

Colori **Rosso fluorescente** **Bianco opalino**
Colors Fluorescent red Opaline white



Peso 4.3 kg
Weight

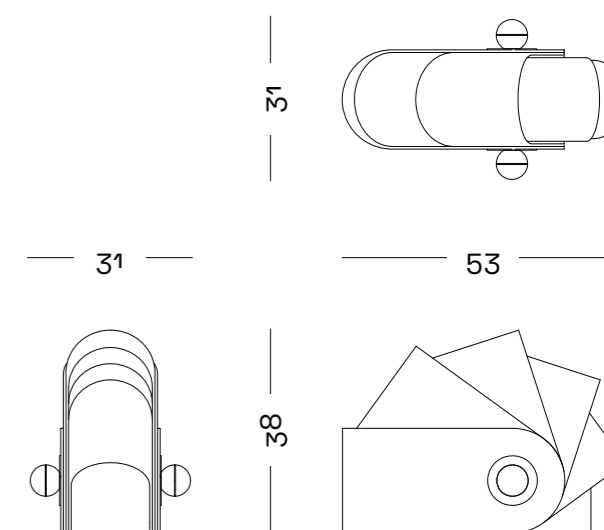

Superstudio

Passiflora

Da un prototipo in cartone dipinto per la mostra "Superarchitettura" [dicembre 1966], manifesto del Radical Design, ha origine l'apparecchio per illuminazione Passiflora. Il cartone è stato sostituito da un materiale trasparente alla luce, trasformando Passiflora in un tronco di colonna luminoso: una colonna la cui sagoma deformata oscilla tra il naturale e l'artificiale, in un gioco di allusioni e ambiguità, corrispondente alla dichiarazione d'intenti del Superstudio, riassunta nel testo "Design d'invenzione e design d'evasione".

The Passiflora lighting fixture comes from a painted cardboard prototype made for the exhibition "Superarchitettura" [December 1966], a manifesto of Radical Design. The cardboard was replaced by a material transparent to light, transforming Passiflora into a truncated luminous column: a column whose deformed profile wavers between natural and artificial, in a game of allusions and ambiguities, corresponding to the statement of intent of Superstudio, summed up in the text "Invention Design and Evasion Design".

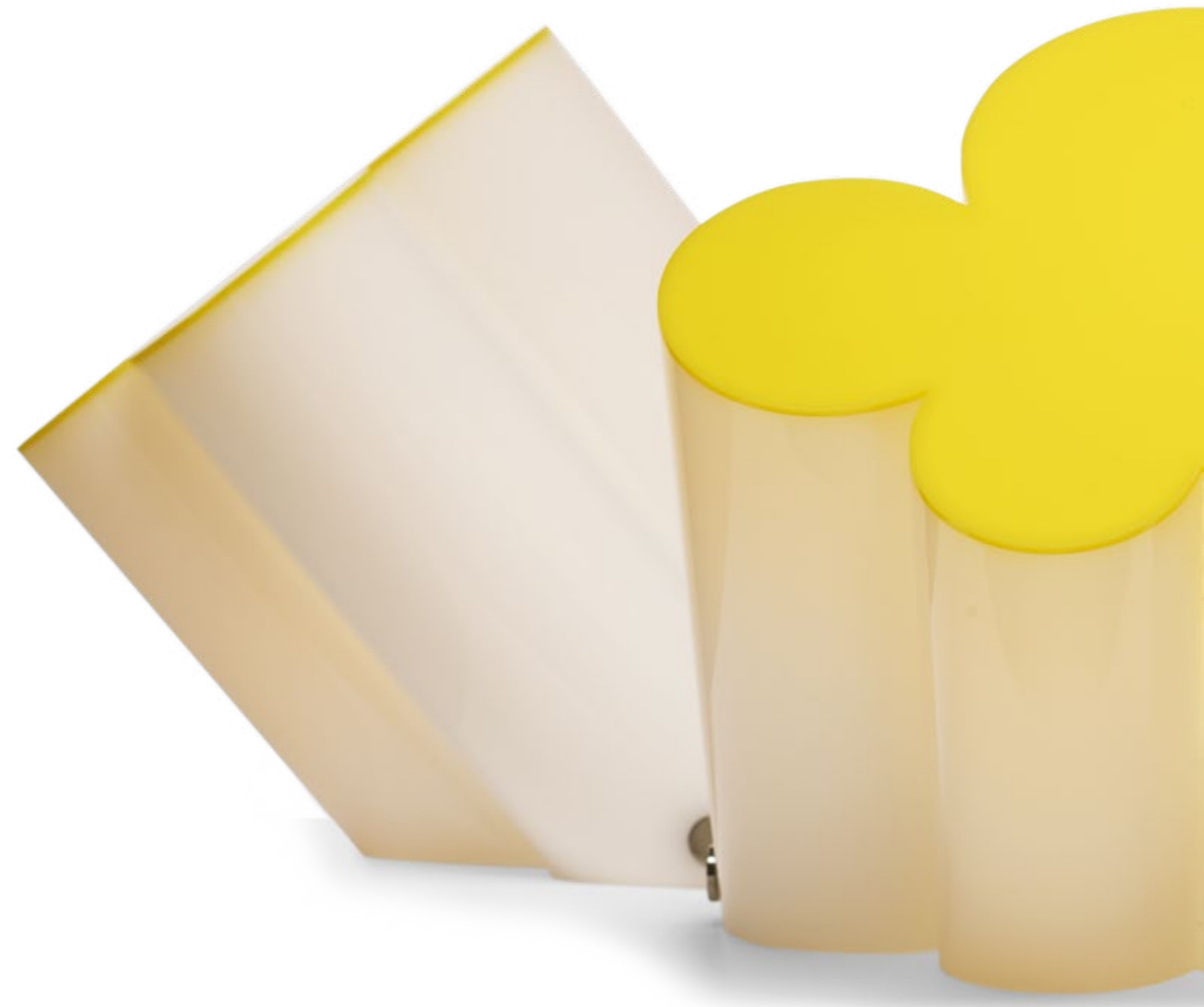







Tipologia Lampada da tavolo
Typology Table lamp

Passiflora

Dimensioni 30[l] x 41[p] x 29[a] cm
Dimensions 30[l] x 41[w] x 29[h] cm

Materiali PMMA giallo e bianco opalino
Materials Yellow and opaline white PMMA

Lampadina 1 x LED A60 E27 10W [max] 6400K
Bulb

Peso 1,5 kg
Weight

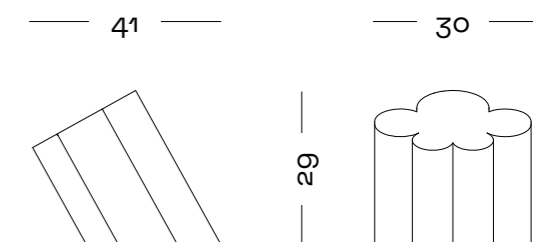

Archizoom Associati

Sanremo

Il prototipo della lampada da terra Sanremo fu il dono di fidanzamento di Dario Bartolini a Lucia Morozzi, offerto nella villa di Roccamare, progettata da Ernesto Nathan Rogers. Sanremo è costituita da un esile fusto metallico e da una chioma, simile a quella di una palma stilizzata, formata da foglie lanceolate di metacrilato trasparente o verde fluorescente che irradiano la luce. Il prototipo prevedeva anche un sonoro, simile al canto di un grillo, che è stato eliminato nella produzione seriale.

«Le nostre visioni erano scintille e alla base c'era il rifiuto del mondo che ci circondava e ogni occasione era buona per concretizzare la nostra visione del mondo. Il nostro desiderio era ridisegnare il mondo... faccio un oggetto con cui vivo, piacevolmente, sensitivamente all'ennesima potenza l'attimo che mi spetta di vivere. Me lo godo, me lo costruisco e lo restituisco agli altri attraverso la mia esperienza... Poiché facevamo architettura, in molti hanno analizzato la nostra idea del progetto, ma queste cose sono nate per occasioni diverse, come un fidanzamento, un matrimonio».

[Lucia Bartolini, 2007]

The prototype of the Sanremo floor lamp was an engagement present from Dario Bartolini to Lucia Morozzi, given to her in the villa in Roccamare designed by Ernesto Nathan Rogers. Sanremo is composed of a slender metal trunk topped by "foliage" like that of a stylized palm tree, formed by lanceolate transparent or fluorescent green methacrylate leaves that radiate light. The prototype also called for a sound similar to the song of a cricket, eliminated in the production version.

«Since we were supposed to be practising architects, many people couldn't grasp what we were up to. In reality many of our objects were created for reasons other than that of architecture: an engagement party, a wedding. Any opportunity was good enough to materialise our vision of the world.»

[Lucia Bartolini, 2007]

126









Sanremo

Tipologia Typology	Lampada da terra Floor lamp	
Dimensioni Dimensions	95[l] x 95[p] x 225[a] cm 95[l] x 95[w] x 225[h] cm	
Materiali Materials	Foglie Leaves	PMMA tagliato a laser Laser-cut PMMA
	Base Base	Metallo laccato nero metallizzato Metallic black lacquered metal
	Palo Pole	Metallo laccato bianco perlato Pearlescent white lacquered metal
Lampadina Bulb	1 x LED GU10 8W [max] 6400K	
Colori Colors	Trasparente Transparent	Verde fluorescente Fluorescent green
		
Peso Weight	12 kg	

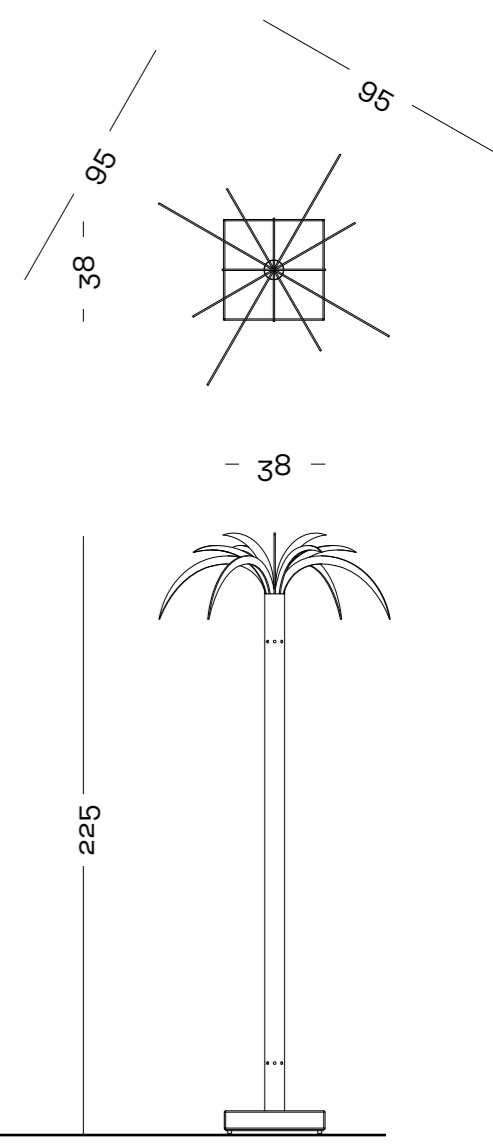

Ettore Sottsass jr.

Ultrafragola

Lo specchio-lampada Ultrafragola con la sua sagoma sinuosa, evocativa di una chioma femminile ondulata, appartiene alla serie dei Mobili Grigi, una camera da letto e un soggiorno per Poltronova e presentati alla terza edizione di Eurodomus nel 1970. Tutti tranne Ultrafragola sono rimasti allo stadio di prototipi.

«Quanto poi alle luci che escono fuori dai “Mobili Grigi”, le tombe non hanno sempre delle tremule luci che illuminano la tristezza degli spazi vaganti nella valle polverosa? E i sottomarini non hanno delle luci verdi tremolanti nella loro pancia? Le luci sono pensate venir fuori dal corpo di fibreglass, come il bianco splendente della pelle bianca dei seni, o il rosso splendente della punta del pene nelle notti pornografiche, qualcosa del genere, voglio dire qualcosa come le lucciole giapponesi che trasformano le notti di maggio in materia solida. Ci può essere qualcosa di più ridicolo?»

[Ettore Sottsass jr., 1970]

Ultrafragola mirrorlamp, with its sinuous profile that suggests long wavy hair, belongs to the “The grey furniture” series of complete bedroom and living room furnishings designed by Ettore Sottsass for Poltronova and presented at the third edition of Eurodomus in 1970. With the exception of Ultrafragola, the models never got beyond the prototype phase.

«As for the lights that are coming out of “The grey furniture”, don’t tombs always have a trembling light to illuminate the blue of the spirits wandering in the valley of dust? Don’t submarines have a trembling green light in their belly? The lights anyway are supposed to come out from the fibreglass bodies, like the ever-glowing of the breast’s white skin, like the ever-glowing of the penis red head in pornographic nights, something of this kind: I mean something like the Japanese lights of the glow worm that are turning the nights into matter. Could anything be more ridiculous?»

[Ettore Sottsass jr., 1970]

134



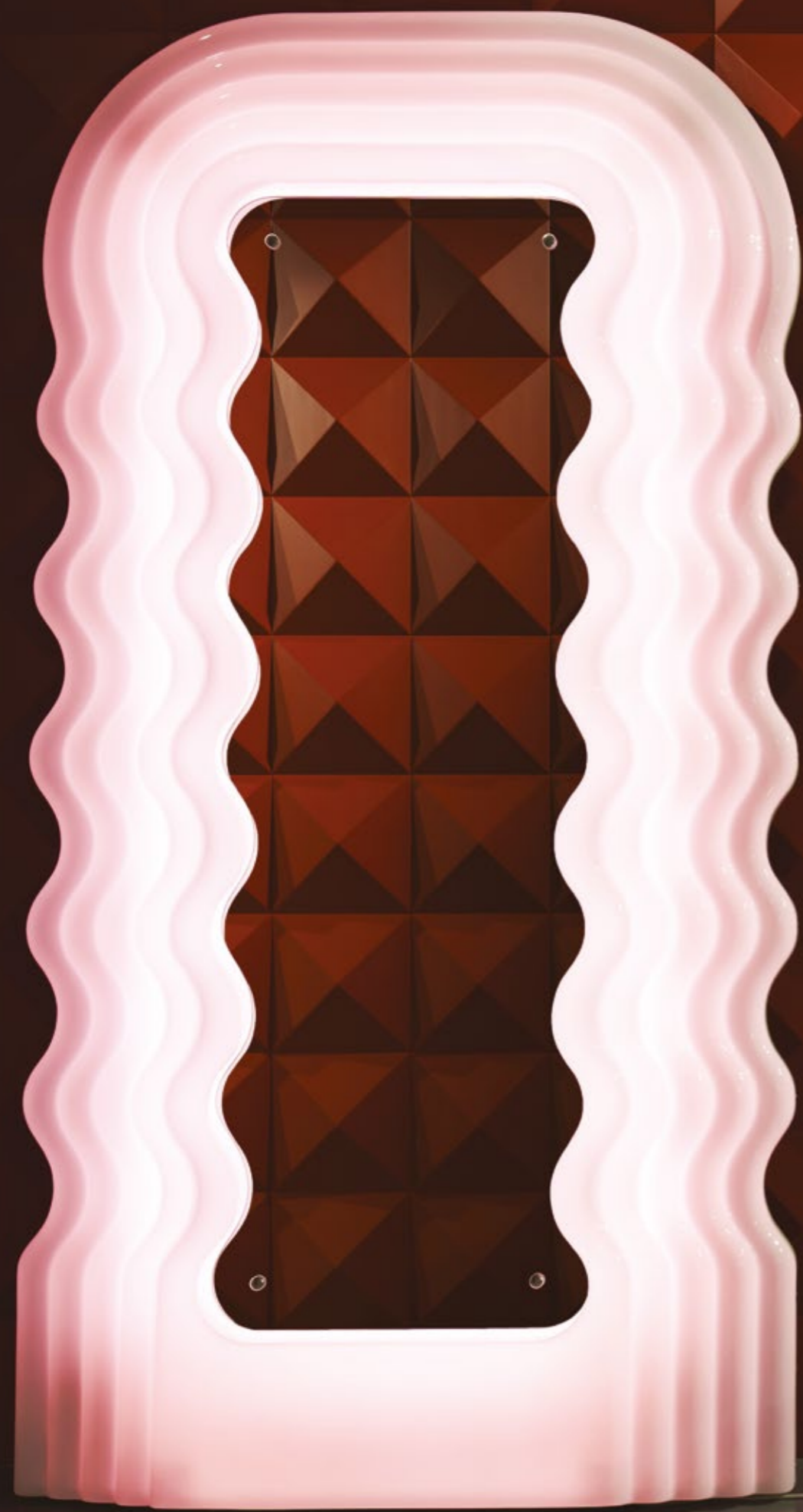





Ultrafragola

Tipologia Specchio/Lampada
Typology Mirror/Lamp

Dimensioni 100[l] x 13[p] x 195[a] cm
Dimensions 100[l] x 13[w] x 195[h] cm

Materiali PETG opalino termoformato, specchio, illuminazione a LED
Materials Vacuum-formed opaline PETG, mirror, LED lighting

Colori Cornice Bianco opalino
Colors Frame Opaline white

Luce Rosa chiaro "Ultrafragola".
Light "Ultrafragola" light pink.
La luminosità e il colore potrebbero essere percepiti leggermente diversi a seconda della luce, dello sfondo e dell'ambiente circostante.
The brightness and the color might be perceived slightly different, depending on the light, the background and the surrounding environment.

Peso 34 kg
Weight

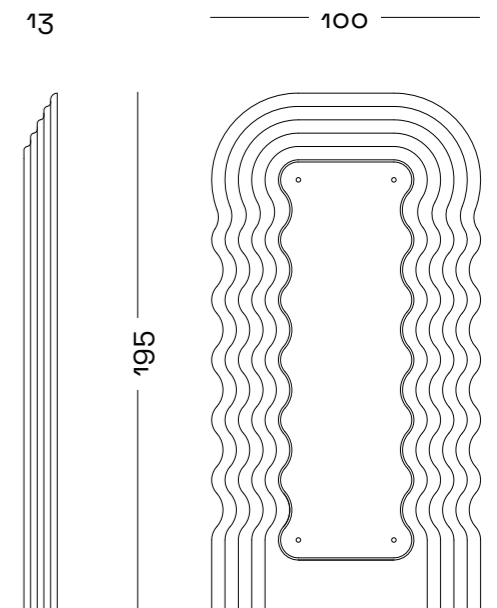

The left side of the page features a series of vertical stripes. There are seven black stripes of equal width, separated by white spaces of equal width. These stripes run from the top to the bottom of the page.

Appendi- abiti Clothes- stands

De Pas, D'Urbino, Lomazzi

Cessato Allarme

L'appendiabiti Cessato Allarme, creato nel 1986 dallo studio De Pas D'Urbino, Lomazzi, messo in produzione da Poltronova nel 1991, denuncia nel nome la sua fonte d'ispirazione: le trombe-allarme disposte sui pali della luce durante l'ultima guerra. In metallo, disponibile in colori brillanti, non ha niente di bellico, anzi rivela una felice nota pop, sottolineata dall'inusuale nome che, come suggerisce Paolo Lomazzi, nel 2020 invita, metaforicamente, «a dar di nuovo fiato alle trombe».

The Cessato Allarme clothes-stand, created in 1986 by the De Pas, D'Urbino, Lomazzi studio, put into production by Poltronova in 1991, reveals its source of inspiration in its name ["Alarm Over!"]: the alarm-trumpets placed on light poles during the last war. Made of metal, available in bright colors, there is nothing warlike about it, indeed it has a cheerful pop touch, emphasised by the unusual name which, as Paolo Lomazzi suggests in 2020, is a metaphorical call to «go and blow the trumpets again.»

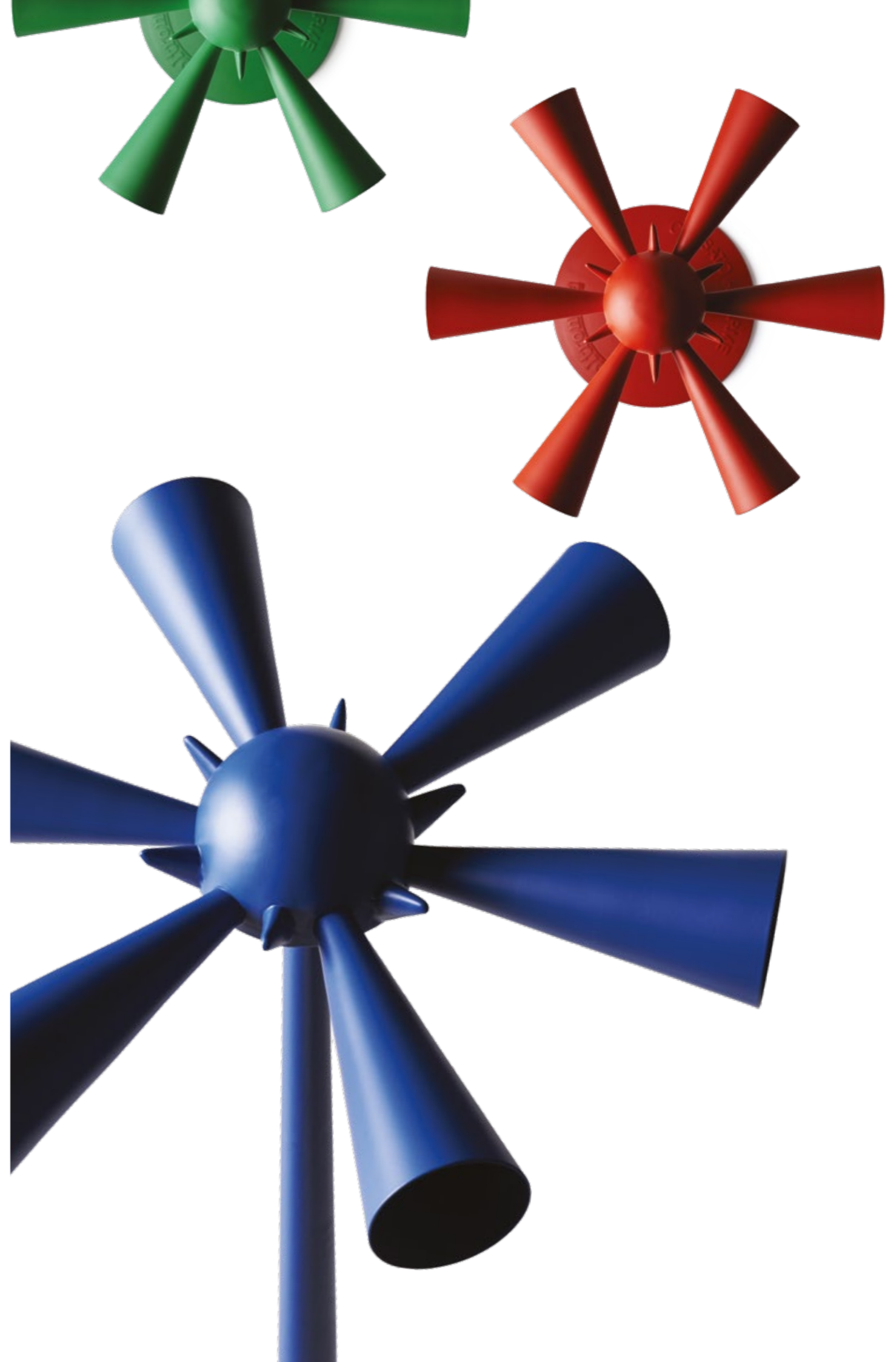











Cessato Allarme

Tipologia Typology	Appendiabiti Clothes-stand				
Dimensioni Dimensions	42,5[l] x 42,5[p] x 154[a] cm 42,5[l] x 42,5[w] x 154[h] cm				
Materiali Materials	Base, Testa Base, Head	Fusione di alluminio Cast aluminum			
	Palo Pole	Metallo Metal			
	Coni Cones	Alluminio Aluminum			
Verniciatura Painting	Idropittura opaca Matte water-based paint				
Colori Colors	Bianco White 	Giallo Yellow 	Rosso Red 	Blu Blue 	Verde Green 
Peso Weight	8,5 kg				



— 42,5 —

— 39 —

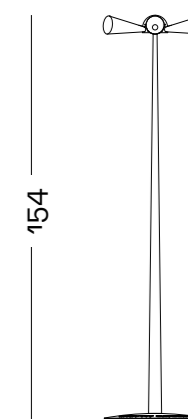

154



Panche Benches

Franco Raggi

Canton

La panca in legno Canton, disegnata da Franco Raggi nel 1988, corredata ai lati da due spazi, contenitori per riviste, libri e per gli elenchi del telefono, all'epoca ancora in uso, destinata, idealmente, agli ingressi, «nasce –come scrive Franco Raggi– da un esercizio grafico: una linea nera che nel suo percorso continuo crea due quadrati collegati da una linea orizzontale. Trascinando questa linea nella terza dimensione ho visto che il solido ottenuto poteva essere una panca, una seduta non comoda, per usi temporanei, nei quali l'ergonomia può essere sacrificata a favore di una immagine astratta, quasi neoplastica. Nei quadrati trasformati in vani a giorno si possono mettere libri e cose».

Nel 2023, in seguito alla rimessa in catalogo del progetto filologico degli anni '80, il Centro Studi Poltronova, insieme all'architetto Franco Raggi, ha editato una nuova versione in due combinazioni di colori rosso e verde, blu e arancio, ciascuna delle quali in due versioni positivo e negativo.

The Canton wooden bench, designed by Franco Raggi in 1988, fitted out with two spaces – containers for magazines, books and phone directories, still in use at the time – ideally designed for home entrances, «was born, –Franco Raggi writes–, from a graphic exercise: a black line which in its continuous path creates two squares connected by a horizontal line. Dragging this line into the third dimensions, I realised that the solid thus obtained could be a bench, not a comfortable seat, but for temporary use, where ergonomics could be sacrifice in favour of an abstract, almost neoplastic image. Books and things could be put in the squares transformed into open compartments.»

In 2023, following the cataloging of the philological project of the 1980s, the Centro Studi Poltronova, together with the architect Franco Raggi, has brought out a new version of Canton, in two combinations, red and green, blue and orange, each with a positive and a negative version.

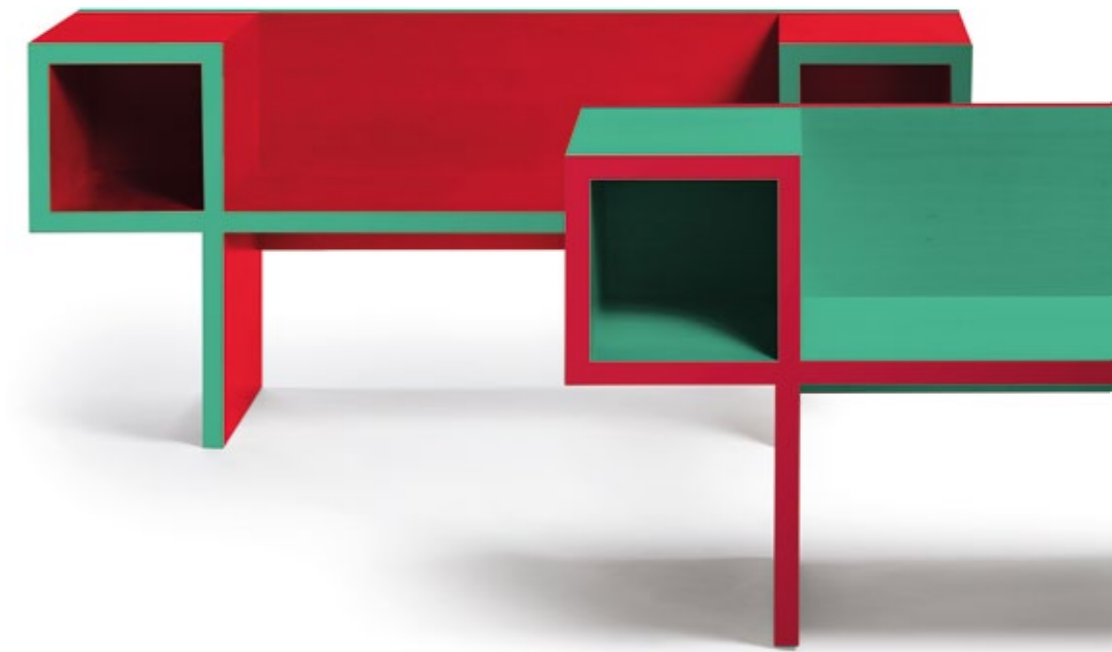









Canton

Tipologia Typology	Panca Bench
Dimensioni Dimensions	170[l] x 45[p] x 75[a] cm 170[l] x 45[w] x 75[h] cm
Materiali Materials	Canton Legno di faggio con bordo melaminico Verniciatura all'acqua Beech wood with melamine edge Water painting
	Canton Color Struttura in legno rivestita in impiallacciato di frassino tinto naturale Verniciatura all'acqua Wooden structure clad in natural dyed ash veneer Water painting
Colori Colors	Canton Faggio/Nero Beech/Black 
	Canton Color Verde/Rosso Rosso/Verde Blu/Arancio Arancio/Blu Green/Red Red/Green Blue/Orange Orange/Blue 
Peso Weight	46 kg

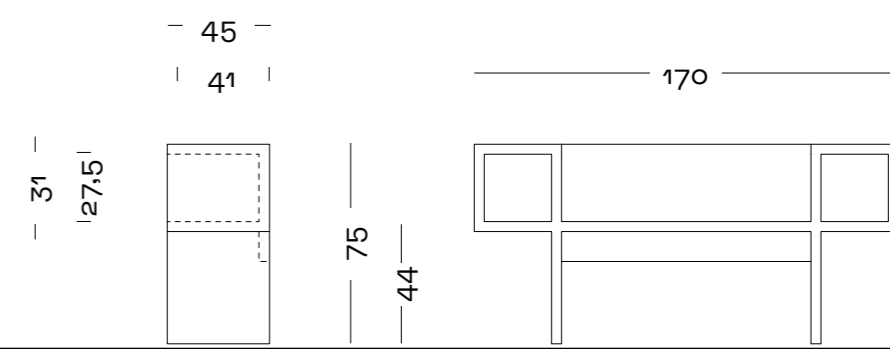



Tavoli Tables

Ron Arad

Split

Il tavolo estensibile Split, progettato da Ron Arad nel 1990 per Poltronova, è uno dei primi pezzi del designer inglese non autoprodotta. Per molti anni fuori produzione, è stato reintrodotta in catalogo nel 2012, nell'ambito del programma di riedizioni del Centro Studi Poltronova. Il piano a listelli di varie essenze lignee permette di modificarne la dimensione. È dotato di eleganti gambe arcuate in acciaio spazzolato, che gli conferiscono una inedita dimensione scultorea.

The Split extendable table designed by Ron Arad in 1990 for Poltronova was one of the first items not self-produced by the English designer. Out of production for many years, it was reinserted in the catalogue in 2012, in the context of the program of reissued pieces of Centro Studi Poltronova. The top made with slats of various types of wood makes it possible to alter the size. It features elegant arched legs in brushed steel, giving the table an original sculptural dimensions.

164







Tipologia Tavolo estensibile
Typology Extendable table

Split

Dimensioni 173/285[l] x 90[p] x 76[a] cm
Dimensions 173/285[l] x 90[w] x 76[h] cm

Materiali Acciaio e legno massello
Materials Steel and massive wood

Peso 65 kg
Weight

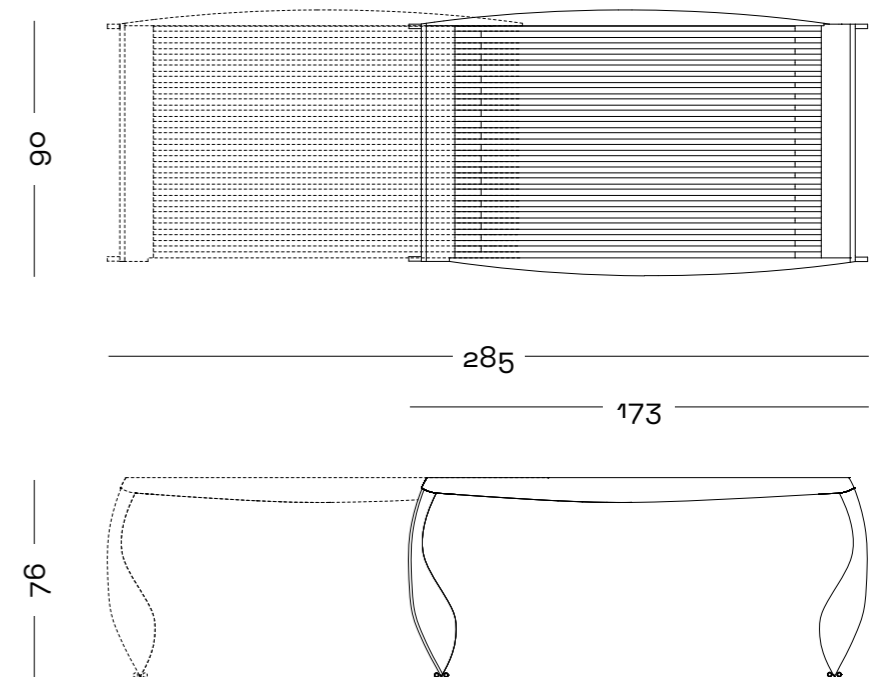

Superstudio

To1

Destinato a accompagnare il divano Sofo, dotato della medesima lunghezza della seduta e di metà della sua larghezza, è ricavato dalla piegatura di una lastra di metacrilato di dodici millimetri di spessore. È disponibile nei colori bianco e rosso.

Created to go together with the Sofo sofa, with the same length as the seat and half the width, this coffee table is made by bending a methacrylate sheet with a thickness of twelve millimeters. In white or red.

170



**THE
FUTURE
IS
BRIGHT**





Tipologia Tavolino/Portariviste
Typology Coffee table/Magazine rack

To1

Dimensioni 82[l] x 41[p] x 30[a] cm
Dimensions 82[l] x 41[w] x 30[h] cm

Materiali PMMA termoformato
Materials Heat-formed PMMA

Colori Rosso Bianco
Colors Red White



Peso 10,5 kg
Weight

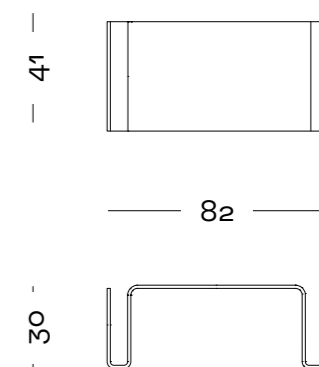

To2

Il tavolino To2, come il To1, è stato disegnato da Superstudio come completamento del progetto di sedute Sofo. Si compone di un piano in laminato che poggia su quattro gambe di forma sferica. Ha la stessa dimensione della poltrona Sofo e per questo contribuisce a evidenziare la componente modulare del progetto. Anche la scelta del colore del piano, rosa, lo rende nelle parole di Adolfo Natalini, un oggetto che «ha addosso un po' di gioia di vivere». Adolfo Natalini e Cristiano Toraldo di Francia lo hanno scelto per uno dei loro autoritratti fotografici più iconici.

The small To2 table, like the To1, was designed by Superstudio to complete the Sofo seat project. It consists of a laminated top resting on four spherically shaped legs. It is the same size as the Sofo armchair, and this helps to emphasize the modular component of the project. Also, the decision to use pink as the color of the top makes it an item «which carries a bit of joie de vivre», as Adolfo Natalini put it. Adolfo Natalini and Cristiano Toraldo di Francia chose it for one of their more iconic self-portraits.

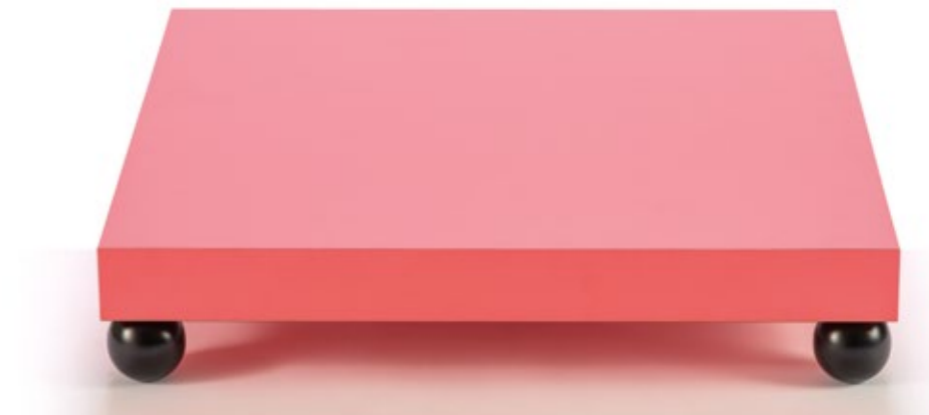





Tipologia Tavolino
Typology Coffee table

To2

Dimensioni 82[l] x 82[p] x 16[a] cm
Dimensions 82[l] x 82[w] x 16[h] cm

Materiali Piano **Compensato laminato rosa heritage**
Materials Top Rose heritage laminated plywood

Gambe **Legno di faggio tornito e verniciato nero**
Legs Black turned and varnished beech wood

Peso 15 kg
Weight

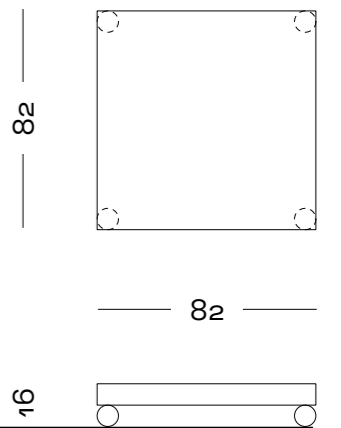



Portafoto
Specchi
Photo
holders
Mirrors

Superstudio

Ofelia Spera Vanitas

Questa serie di piccoli specchi e portafoto di Superstudio ha origine dall'idea di utilizzare gli scarti di lavorazione del marmo e fa parte di una serie costituita da piccoli specchi e da un portafoto di Superstudio. Un'opera di bricolage, più che di creazione, la definì all'epoca il gruppo fiorentino. Mediante studiate fresature l'irregolare pezzo di marmo diventa il prezioso supporto per una lastra di metacrilato da utilizzare come portafoto. Ofelia, Spera e Vanitas rappresentano, ante litteram, un progetto di trasformazione in grado di restituire una nuova raffinata estetica ai residui industriali.

This series of small mirrors and a photo holder by Superstudio began with the idea of using scraps from the processing of marble. An operation of bricolage, rather than creation, as the Florence-based group stated at the time. Careful milling of the irregular marble pieces makes them become the precious support for a mirror and for two sheets of methacrylate to use as photo frames. Ofelia, Spera and Vanitas, ahead of their time, represent a project of transformation capable of granting a new, refined aesthetic to industrial scrap.

Spera

Vanitas

Ofelia

184













Ofelia Spera Vanitas

Tipologia Typology	Piccoli specchi e portafoto Small mirrors and photo holders	
Dimensioni Dimensions	Ofelia	13[l] x 9[p] x 27[a] cm 13[l] x 9[w] x 27[h] cm
	Spera	16[l] x 9[p] x 37[a] cm 16[l] x 9[w] x 37[h] cm
	Vanitas	20[l] x 11,5[p] x 21[a] cm 20[l] x 11,5[w] x 21[h] cm
Materiali e Colori Material and Colors	Ofelia	PMMA arancio-magenta fluorescente e marmo Fluorescent orange-magenta PMMA and marble Rosso Francia 
	Spera	PMMA arancio-magenta fluorescente, magneti, specchio e marmo Fluorescent orange-magenta PMMA, magnets, mirror and marble Nero Marquina 
	Vanitas	PMMA arancio-magenta fluorescente, specchio e marmo Fluorescent orange-magenta PMMA, mirror and marble Rosso Francia Nero Marquina  
Peso Weight	Ofelia	1,2 kg
	Spera	1,7 kg
	Vanitas	1 kg

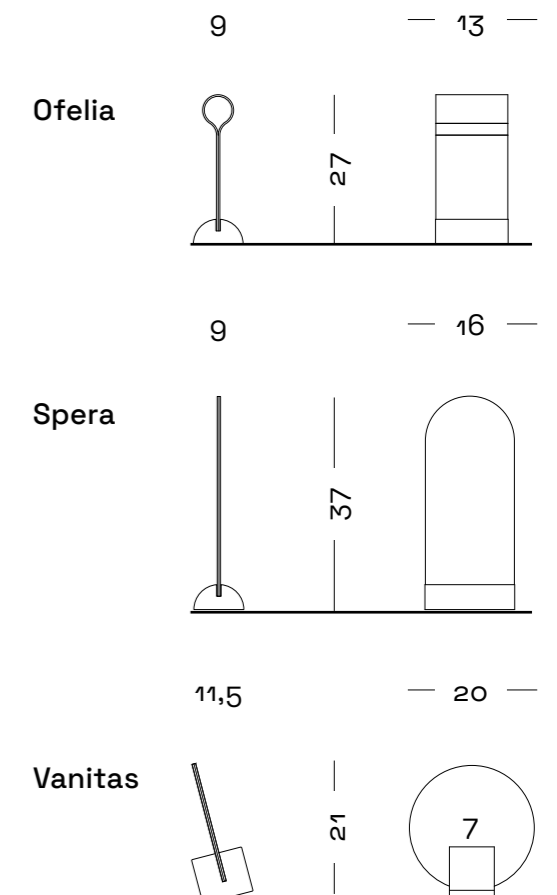



Tappeti Rugs

Lapo Bina

Autostrada

Firmato per Poltronova da Lapo Binazzi, il tappeto Autostrada è esattamente quello che promette: una carreggiata modulata in curve e rettilinei, disponibile in tre differenti combinazioni di colori nella versione rieditata dal visionario designer fiorentino, ex membro dello storico collettivo radicale degli anni Sessanta UFO, sulla base di un disegno conservato nell'archivio del Centro Studi Poltronova per il Design. Prodotto in un unico esemplare da Poltronova nel 1990 in occasione della mostra "Il Dolce Stil Novo [della casa]" curata da Andrea Branzi alla Fondazione Palazzo Strozzi di Firenze, il tappeto torna centrale per indagare la dimensione del progetto, ovvero la casa, «cioè la nostra sopravvivenza all'interno dell'universo artificiale, dentro la violenza e alla volgarità dei tempi, nello sradicamento compiuto dai flussi invadenti dell'informazione».

Signed for Poltronova by Lapo Binazzi, the rug Autostrada is exactly what it promises: a roadway modulated in curves and straight lines, available in the three different color combinations in the version reissued by the visionary Florentine designer on the basis of a drawing kept in the archives of the Centro Studi Poltronova per il Design. Produced in a single copy by Poltronova in 1990 on the occasion of the exhibition "Il Dolce Stil Novo [della casa]" curated by Andrea Branzi at the Fondazione Palazzo Strozzi in Florence, the rug returns to show itself as one of the objects that were put on display to investigate the central dimensions of the project, the home, «that is, our survival within the artificial universe, within the violence and vulgarity of the times, in the uprooting accomplished by the intrusive flows of information.»

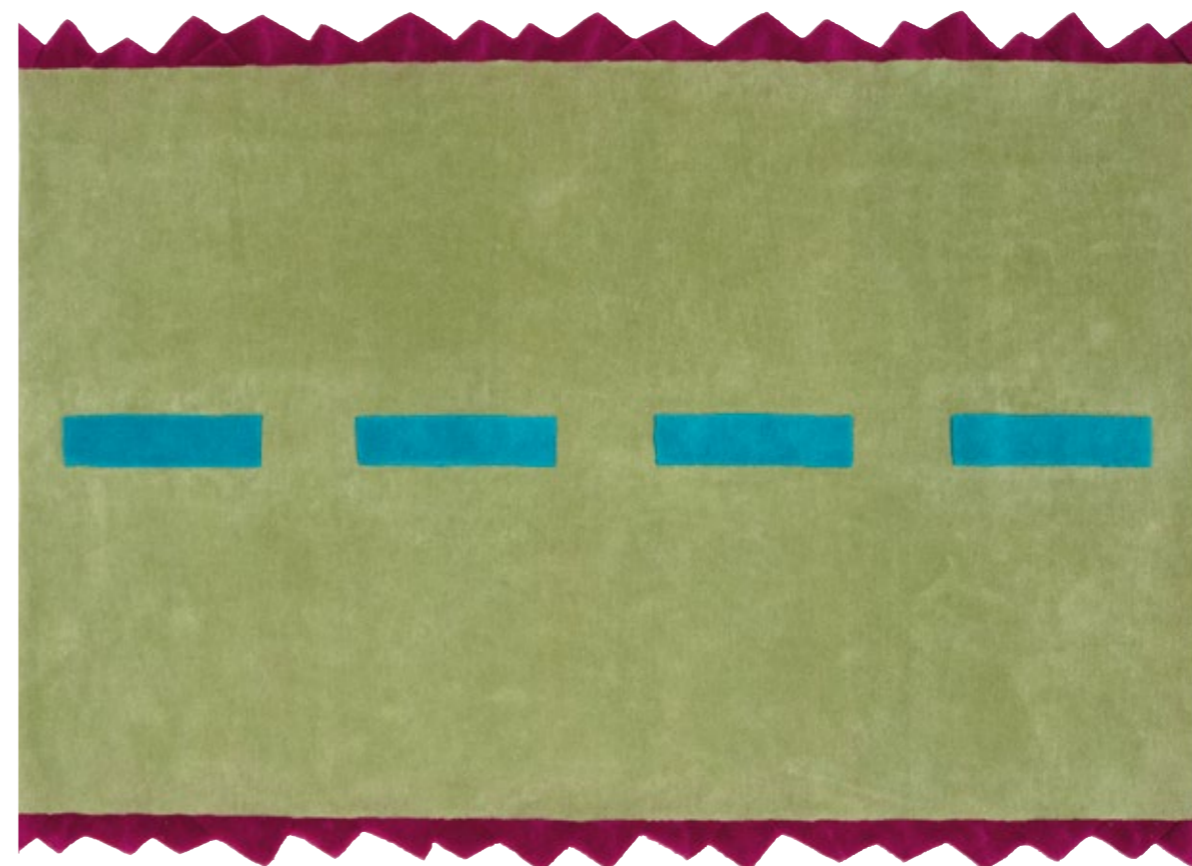
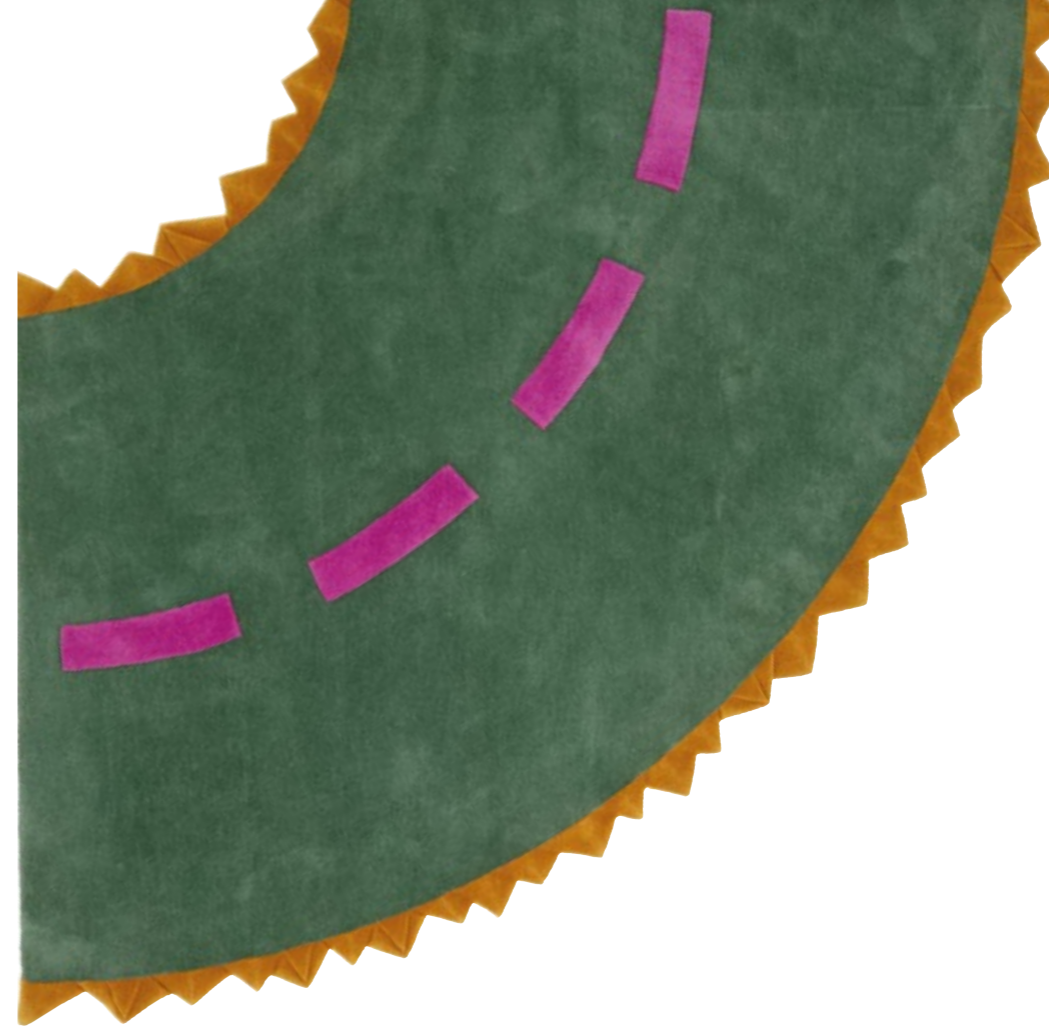

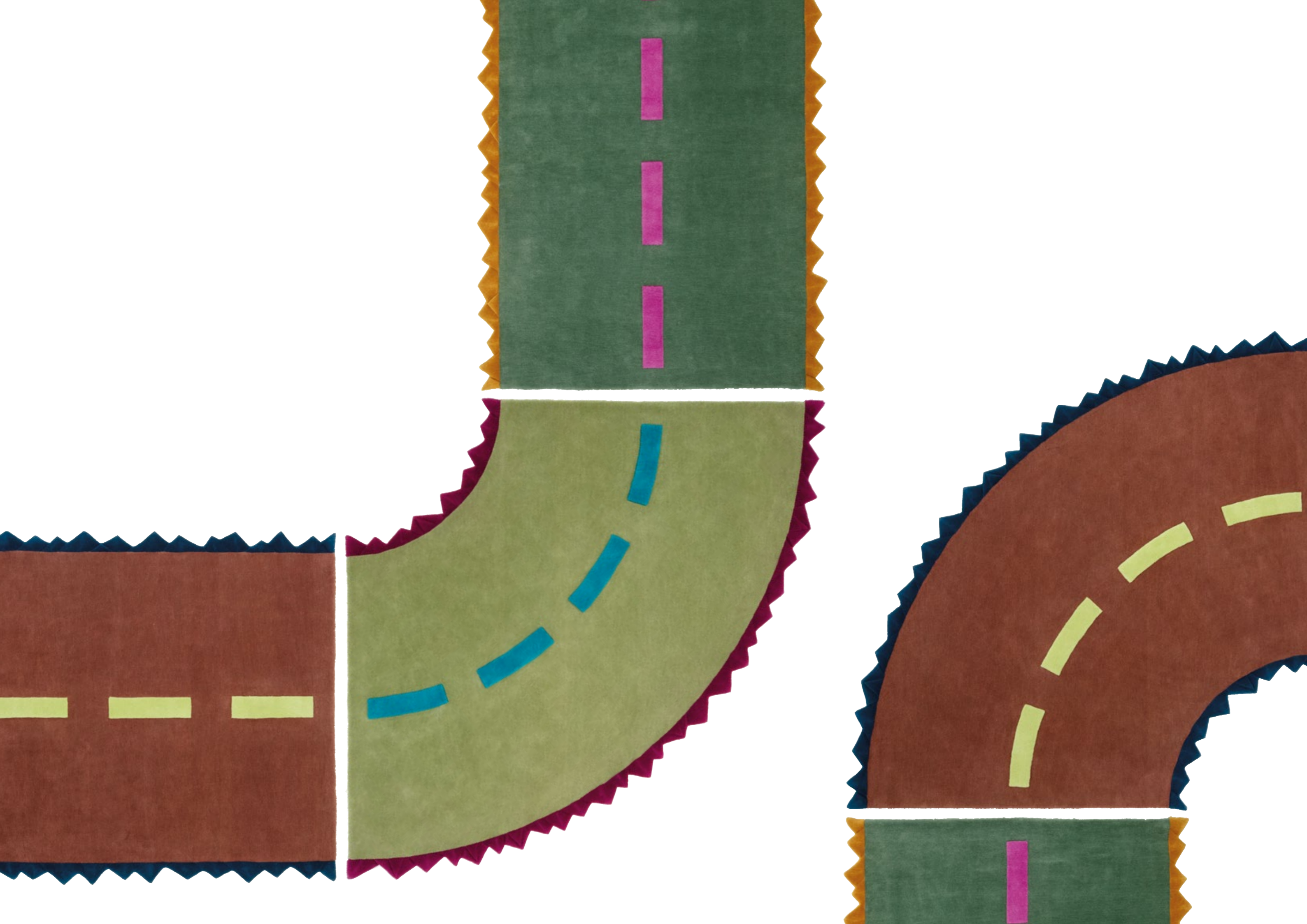

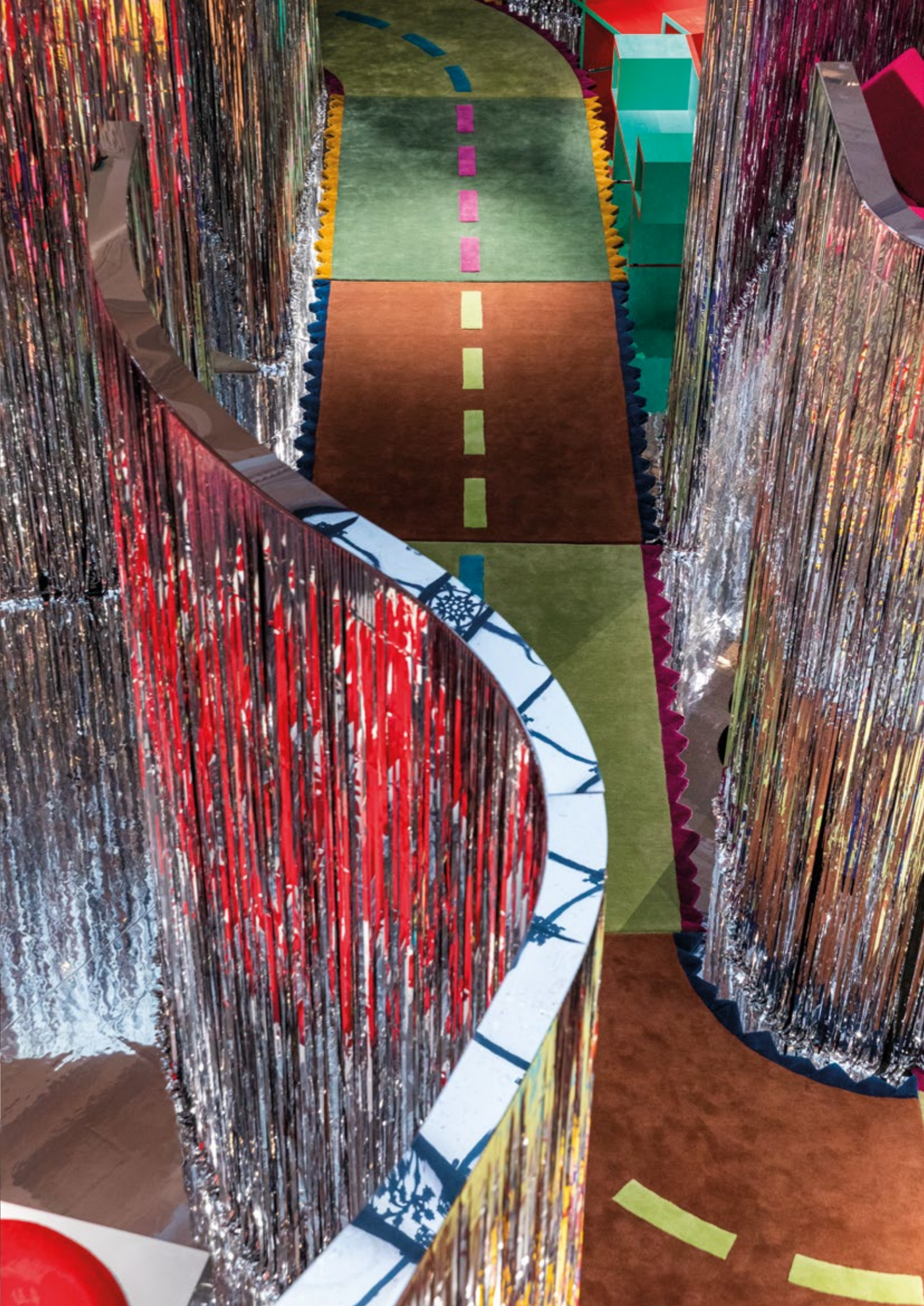







Autostrada

Tipologia Typology	Tappeto Rug	
Dimensioni Dimensions	Rettilineo Straight	240[l] x 170[p] cm ±2% 240[l] x 170[w] cm ±2%
	Curva Curve	235[l] x 235[p] cm ±2% 235[l] x 235[w] cm ±2%
Materiali Materials	100% Lana 100% Wool	
Atelier	India	
Manifattura Production	Taftato a mano Handtufted	
Colori Colors	A61	Giallo indiano, grigio corazzato e rosa lampone Indian yellow, armoured grey and raspberry pink 
	A62	Telemagenta, grigio pastello e turchese Telemagenta, pastel grey and turquoise 
	A63	Blu zaffiro, grigio tortora e verde germoglio Sapphire blue, dove grey and sprout green 
Peso Weight	Rettilineo Straight	19 kg
	Curva Curve	27 kg

Curva
Curve

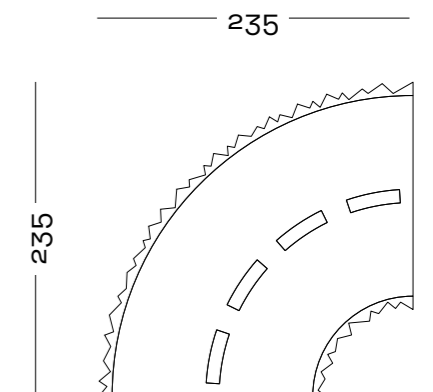

Rettilineo
Straight

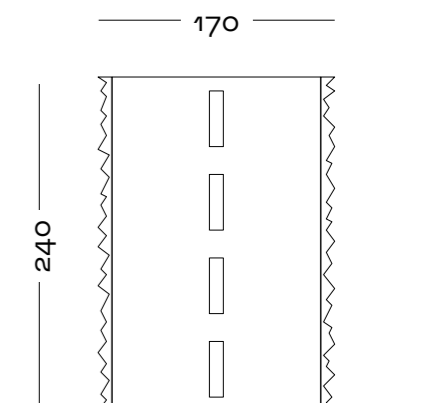

Archizoom Associati

Cielo Farfalla Prato

made by
Centro Studi Poltronova per il Design

with
cc-tapis

Farfalla, Prato e Cielo sono i tre tappeti ispirati al pattern Farfalla disegnato dal gruppo Archizoom nel 1967 come ricerca di un acido contrasto tra il decoro floreale, di matrice liberty, e le sperimentazioni che in quegli anni si stavano manifestando nell'ambito della Pop Art. Tre reinterpretazioni, in tre diverse forme, delle parti principali che componevano il pattern originale. I tappeti sono caratterizzati da un'esplosione di colori primari e di forme semplici e geometriche campite da motivi decorativi -tipici delle produzioni di artisti come Roy Lichtenstein e Andy Warhol- come pois, scacchi e strisce oblique.

Cielo, Farfalla and Prato are three rugs inspired by the Farfalla pattern designed by the Archizoom group in 1967 in their quest for an acid contrast between the floral, art nouveau decor and the experimentation that was taking place in Pop Art in those years. A reinterpretation of the main parts that made up the original pattern. The rugs are characterized by an explosion of primary colors and simple, geometric shapes spanned by decorative motifs—typical of the productions of artists such as Roy Lichtenstein and Andy Warhol—such as polka dots, checks and oblique stripes.











Tipologia Typology	Tappeto Rug	
Dimensioni Dimensions	Cielo/Prato	265[l] x 365[p] cm ±2% 265[l] x 365[p] cm ±2%
	Farfalla	262[l] x 275[p] cm ±2% 262[l] x 275[w] cm ±2%
Materiali Materials	100% Lana 100% Wool	
Atelier	India	
Manifattura Production	Taftato a mano Handtufted	
Peso Weight	Cielo/Prato	31 kg
	Farfalla	30 kg

Cielo Farfalla Prato

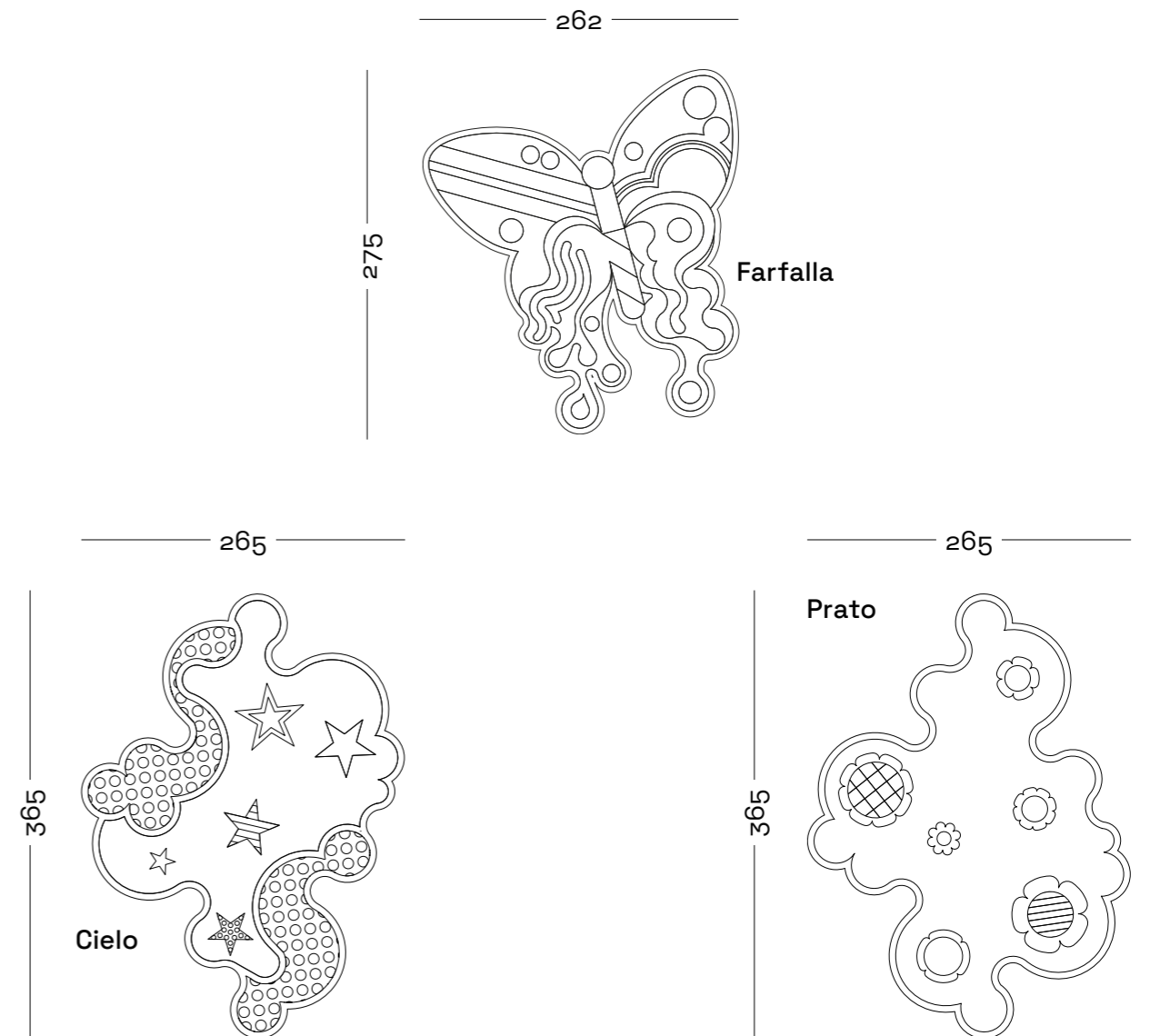

Sofo

Superstudio

made by
Centro Studi Poltronova per il Design

with
cc-tapis

Dedicato all'omonimo sistema modulare iperpop di Superstudio, il tappeto **Sofo** è frutto di ricerca nell'archivio del Centro Studi Poltronova. La sua forma altro non è che il marchio, disegnato negli anni Sessanta dagli stessi componenti di Superstudio, che caratterizzava gli imballi di spedizione del prodotto. Una composizione di cerchi concentrici con, nella parte centrale, forme tipografiche di natura geometrica che dichiarano il nome del prodotto. Il tappeto è disponibile in due varianti che riprendono le tipiche partiture cromatiche del divano: Verosa e Rosancio.

Dedicated to the homonymous hyperpop modular system by Superstudio, the **Sofo** rug is the result of research in the archives of Centro Studi Poltronova. Its shape is none other than the marking, designed in the 1960s by the same members of Superstudio, which characterized the product's shipping packages. A composition of concentric circles with, in the central part, typographic shapes of a geometric nature declaring the name of the product. The rug is available in two variants that take up the typical color scores of the sofa: Verosa and Rosancio.



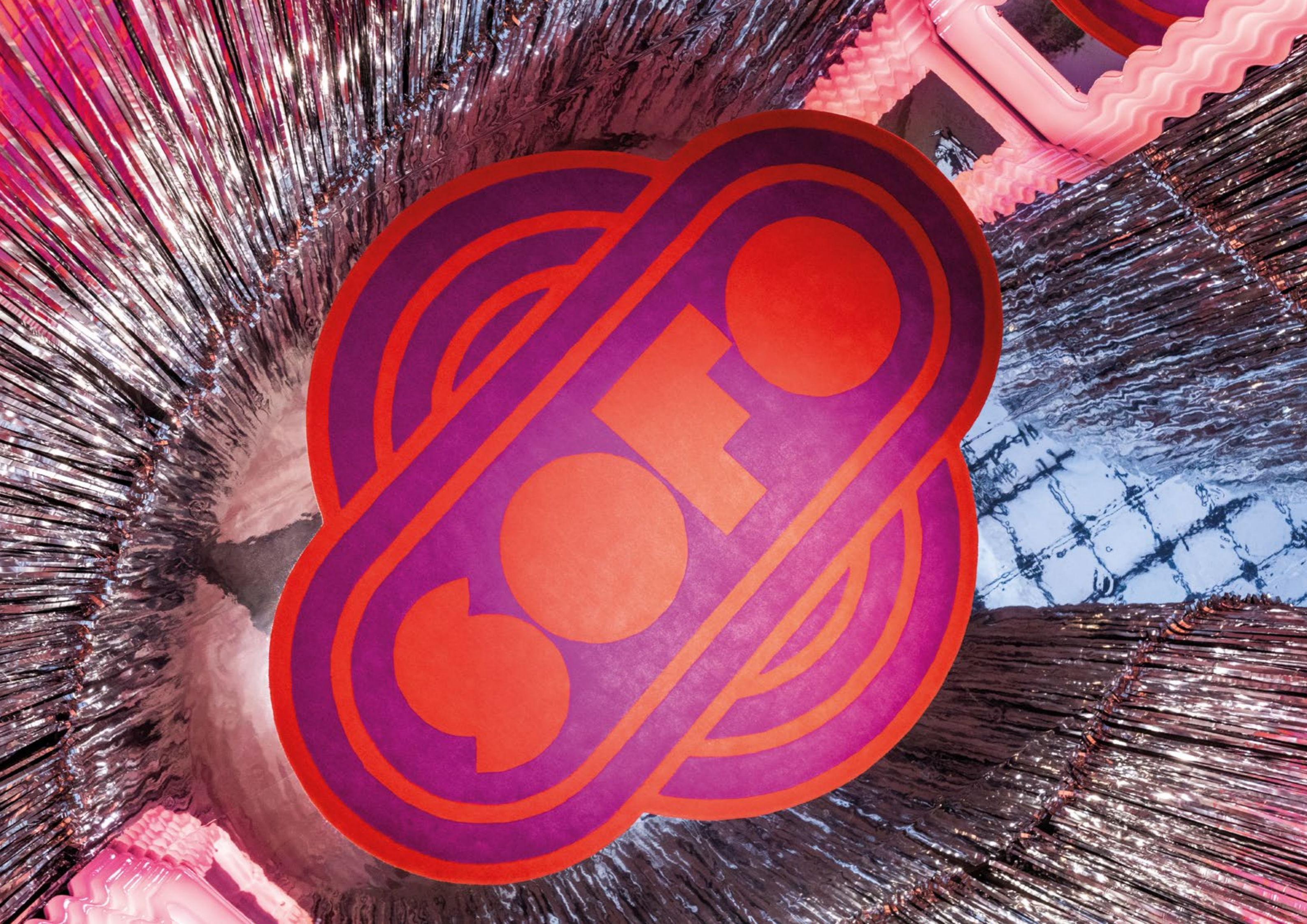





Sofo

Tipologia Tappeto
Typology Rug

Dimensioni 240[l] / 300[p] cm $\pm 2\%$
Dimensions 240[l] / 300[w] cm $\pm 2\%$

Materiali 100% Lana
Materials 100% Wool

Atelier India

Manifattura Taftato a mano
Production Handtufted

Colori Verosa [Verde e Rosa]
Colors [Green and Pink]



Rosancio [Rosa e Arancio]
[Pink and Orange]



Peso 29 kg
Weight

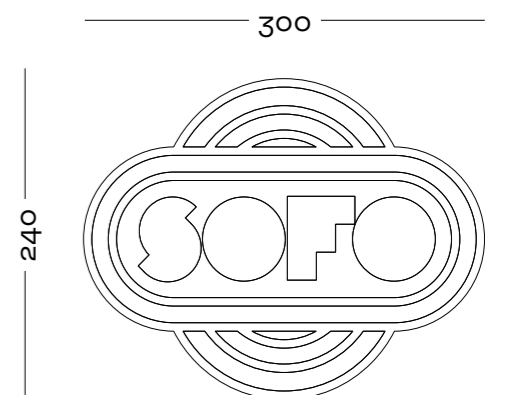

D

Stella Stellina

Il simbolo della stella, spesso utilizzato negli sport di squadra per indicare le vittorie di particolari competizioni, da sempre è tratto distintivo della poltrona Joe, disegnata da De Pas, D'Urbino, Lomazzi. Dapprima marchiato a fuoco sulla pelle nella versione originale, poi ricamato nelle edizioni speciali in denim ed eco-pelliccia, oggi è anche il segno generatore dei tappeti dedicati all'iconica poltrona. Stella e Stellina, nelle colorazioni in grigio e blu marino, sono un omaggio alla divisa storica dei New York Yankees, così come la poltrona per la quale la stella era nata è a sua volta un tributo a un mito della cultura popolare americana, il giocatore simbolo della squadra newyorkese Joe DiMaggio.



Stella

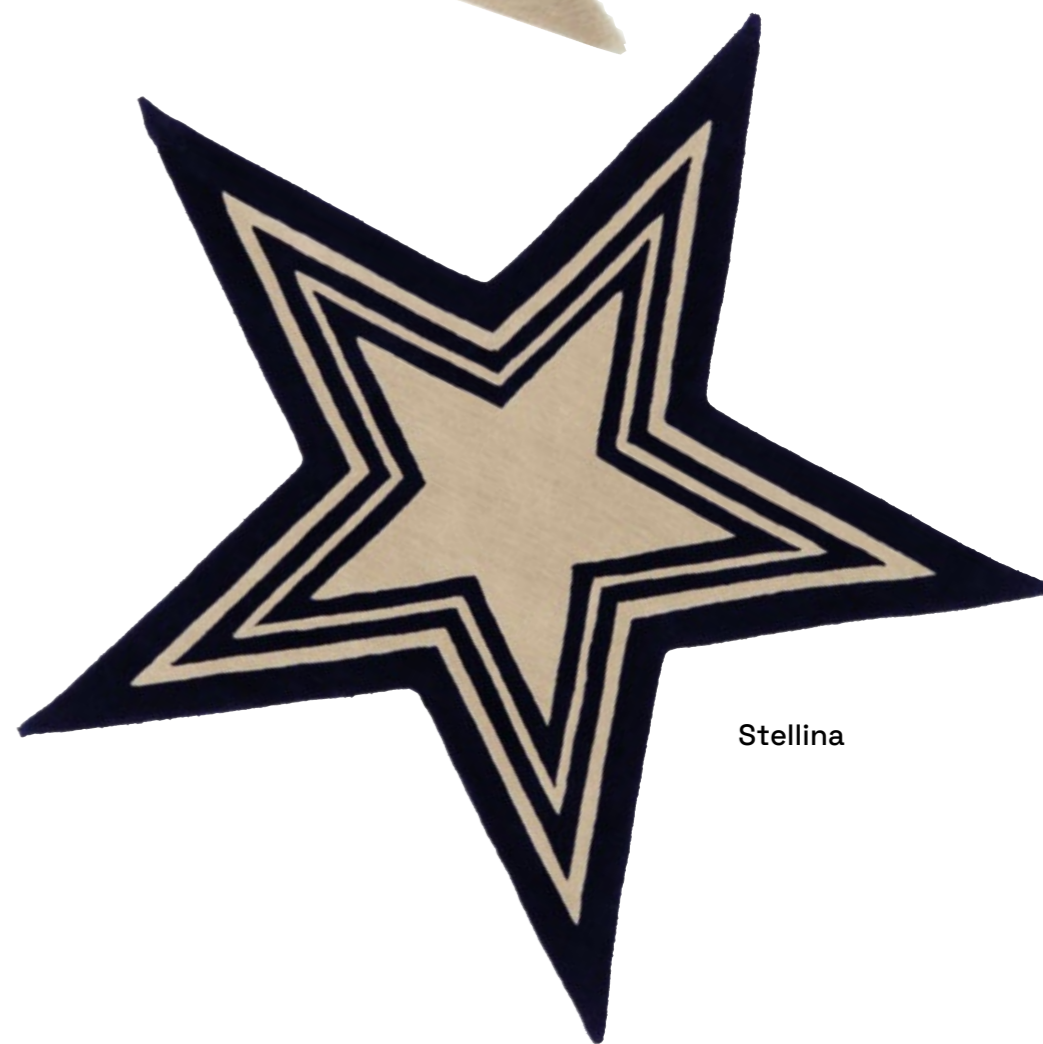



Stellina







Stella Stellina

Tipologia Typology	Tappeto Rug
Dimensioni Dimensions	Stella 263[l] x 250[p] cm ±2% 263[l] x 250[w] cm ±2%
	Stellina 152[l] x 145[p] cm ±2% 152[l] x 145[w] cm ±2%
Materiali Materials	100% Lana 100% Wool
Atelier	India
Manifattura Production	Taftato a mano Handtufted
Colori Colors	Stella Grigio / Blu marino Grey / Navy blue 
	Stellina Blu marino / Grigio Navy blue / Grey 
Peso Weight	Stella 12 kg
	Stellina 5 kg

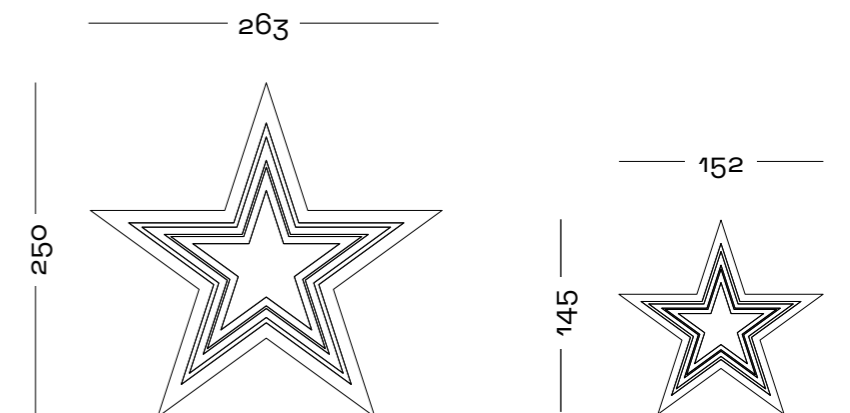

Designer Designers

230

Split

Cielo, Farfalla, Prato / Mies / Farfalla / Safari / Sanremo / Superonda

Ron Arad

Ron Arad è nato a Tel Aviv nel 1951. Ha studiato alla Jerusalem Academy of Art [1971-73] e all'Architectural Association di Londra [1974-79]. Nel 1989 con Caroline Thorman fonda Ron Arad Associates. È stato professore di Design presso la Hochschule di Vienna dal 1994 al 1997 e professore di Design del mobile presso il Royal College of Art di Londra dal 1997. È professore di Design del prodotto sempre presso il Royal College of Art. Ha esposto presso i principali musei e gallerie d'arte del mondo e il suo lavoro fa parte delle collezioni permanenti del Centre Georges Pompidou di Parigi, del MoMA di New York, del Victoria and Albert Museum di Londra e del Vitra Design Museum in Germania. Ron Arad progetta per alcune delle principali aziende internazionali tra le quali: Kartell, Vitra, Moroso, Fiam, Triade, Alessi, Flos. Tra i progetti di architettura si ricordano: lo Showroom Maserati, Italia; la Selfridges Technology Hall a Londra; il Tel Aviv Opera Foyer in Israele.

Ron Arad was born in Tel Aviv in 1951. He studied at the Jerusalem Academy of Art [1971-73] and at the London Architectural Association [1974-79]. In 1989, with Caroline Thorman, he founded Ron Arad Associates. He was professor of Design at the Vienna Hochschule from 1994 to 1997 and has been professor of Furniture Design at the London Royal College of Art since 1997. Always at the Royal College of Art, he is professor of Product Design. Leading museums and art galleries around the world have hosted his works, which are also part of the permanent collections of the Centre Georges Pompidou in Paris, the MoMA in New York, the Victoria and Albert Museum in London and the Vitra Design Museum in Germany. Ron Arad designs for such leading international firms as: Kartell, Vitra, Moroso, Fiam, Triade, Alessi, Flos. Among his architectural designs, we may remember: the Maserati Showroom, Italy; the Selfridges Technology Hall in London; the Tel Aviv Opera Foyer in Israel.

Archizoom Associati

Il gruppo, fondato a Firenze nel 1966 da Andrea Branzi, Gilberto Corretti, Paolo Deganello e Massimo Morozzi, ai quali si aggiunsero nel 1968 Dario e Lucia Bartolini, è una delle voci più autorevoli dell'intero movimento dell'architettura radicale. Insieme a Superstudio, nel dicembre 1966 organizza la mostra Superarchitettura. Del 1968 è la partecipazione alla XIV Triennale con il progetto Centro di Cospirazione Elettica, del 1972 la partecipazione alla mostra Italy: The New Domestic Landscape al MoMA di New York, e del 1973 la fondazione della Global Tools insieme ai principali esponenti dell'area radicale. Tra il 1966 e il 1973 realizzano per la Poltronova alcuni mobili provocatori che aprono la stagione del nuovo design: i divani Superonda e Safari [1966-67], lume Sanremo [1968] e poltrona Mies [1969]. Del 1968 è la serie dei Gazebo, pubblicata sul primo numero della rivista "Pianeta Fresco" di Ettore Sottsass jr. Parallelamente al lavoro sperimentale nel campo del design, gli Archizoom conducono una ricerca sulla città, l'ambiente e la cultura di massa che culmina nel grande progetto della No-Stop City. Il lavoro di ricerca teorica degli Archizoom ha indirizzato alcune delle tematiche del radicale, in particolare con le Radical Notes di Branzi su "Casabella". Il gruppo si scioglie nel 1974.

This group, founded in Florence in 1966 by Andrea Branzi, Gilberto Corretti, Paolo Deganello and Massimo Morozzi, followed in 1968 by Dario and Lucia Bartolini, was one of the most authoritative voices of the whole radical architecture movement. Together with Superstudio, in 1966, they organised the show Superarchitettura. In 1968, they took part in the 14th Triennale with the Centro di Cospirazione Elettica project; in 1972, they took part in the show Italy: The New Domestic Landscape at the New York MoMA, and in 1973 they founded Global Tools together with the main representatives of the radical area. Between 1966 and 1973, they made some provocative furniture for Poltronova, which opened the season of new design: the Superonda and Safari couches [1966-67], the Sanremo lamp [1968] and the Mies armchair [1969]. The Gazebo series was published in 1968 in the first issue of Ettore Sottsass jr's magazine, "Pianeta Fresco". Parallel to experimental work in the field of design, Archizoom carried out research on the city, the environment and mass culture which peaked in the great project for a No-Stop City. Theoretical research work by Archizoom addressed some themes of the radical movement, especially Branzi's Radical Notes on "Casabella". The group broke up in 1974.

Lapo Binazzi

Lapo Binazzi nasce a Firenze nel 1943, studia architettura negli anni Sessanta e in quel contesto fonda nel 1967 gli UFO [con Foresi, Maschietto, Bachi e Cammeo], gruppo che si inserisce nel clima sperimentale dell’architettura radicale, con il quale partecipa a numerose mostre internazionali come la XIV Triennale di Milano [1968], la Biennale di Parigi [1971], Contemporanea a Roma [1974], la Biennale di Venezia [1978]. Binazzi nel 1973 è, con gli UFO, uno dei fondatori della Global Tools, laboratorio di architettura sperimentale. Dopo l’esperienza con gli UFO, Binazzi continua l’attività di architetto–artista–designer partecipando a numerose mostre come Alchimia a Firenze [1981], Documenta 8 a Kassel [1987] e Il Dolce Stil Novo della Casa a Firenze [1991]. Nel 1975 fonda un atelier laboratorio di oggetti di architettura dove realizza in proprio diversi modelli di lampade. Affianca alle altre attività quella di performer, realizza film e videotapes, scrive per Domus e Modo, nel 1981–82 tiene un workshop all’Architectural Association a Londra. Considerando il design come fenomeno di pura comunicazione, la sua ricerca si incentra sul tentativo di far coincidere l’esperienza artistica con la sperimentazione nel design stesso.

Lapo Binazzi was born in Florence in 1943. He studied architecture in the 1960s, and in that context in 1967[with Foresi, Maschietto, Bachi and Cammeo] he founded UFO, a group that was part of the experimental climate of radical architecture, with which he participated in numerous international exhibitions such as the XIV Milan Triennale [1968], the Paris Biennale [1971], Contemporanea in Rome [1974], the Venice Biennale [1978]. In 1973, Binazzi was one of the founders of Global Tools, a laboratory of experimental architecture, with UFO. After his experience with UFO, Binazzi continued his activity as architect–artist–designer participating in numerous exhibitions such as Alchimia in Florence [1981], Documenta 8 in Kassel [1987] and Il Dolce Stil Novo della Casa in Florence [1991]. In 1975 he founded an atelier–workshop of architectural objects where he made several lamp models on his own. Alongside his other activities, he also worked as a performer, made films and videotapes, wrote for Domus and Modo, and held a workshop at the Architectural Association in London in 1981–82. Considering design as a phenomenon of pure communication, his research focuses on the attempt to make artistic experience coincide with experimentation in design itself.

Lapo Binazzi

Lapo Binazzi was born in Florence in 1943. He studied architecture in the 1960s, and in that context in 1967[with Foresi, Maschietto, Bachi and Cammeo] he founded UFO, a group that was part of the experimental climate of radical architecture, with which he participated in numerous international exhibitions such as the XIV Milan Triennale [1968], the Paris Biennale [1971], Contemporanea in Rome [1974], the Venice Biennale [1978]. In 1973, Binazzi was one of the founders of Global Tools, a laboratory of experimental architecture, with UFO. After his experience with UFO, Binazzi continued his activity as architect–artist–designer participating in numerous exhibitions such as Alchimia in Florence [1981], Documenta 8 in Kassel [1987] and Il Dolce Stil Novo della Casa in Florence [1991]. In 1975 he founded an atelier–workshop of architectural objects where he made several lamp models on his own. Alongside his other activities, he also worked as a performer, made films and videotapes, wrote for Domus and Modo, and held a workshop at the Architectural Association in London in 1981–82. Considering design as a phenomenon of pure communication, his research focuses on the attempt to make artistic experience coincide with experimentation in design itself.

Nigel Coates

Architetto, designer e autore nato nel 1949. Ha studiato all’Università di Nottingham e successivamente all’Architectural Association. Architetto radicale, considera la città come un organismo vivente. Nel 1984 pubblica la rivista–manifesto “NATO” [Narrative Architecture Today]. Arte e letteratura giocano un ruolo importante in molti dei suoi progetti. Coates ha progettato e realizzato interni, mostre ed edifici nel mondo. Tra questi: Caffè Bongo, The Wall, Noah’s Ark e Art Silo in Giappone; il National Centre for Popular Music [oggi The Hub], Powerhouse::uk e il Geffrye Museum nel Regno Unito. Nel corso della sua eclettica carriera ha inoltre realizzato progetti sperimentali per eventi d’arte e design, tra i quali Ecstacity, 1992, Architectural Association; Mixtacity, 2007, Tate Modern; Hypnerotosphere, 2008, XI Biennale di Architettura di Venezia. Ha inoltre disegnato prodotti per Alessi, AV Mazzega, Ceramica Bardelli, Frag, Fratelli Boffi, Poltronova, Slamp e Varaschin. Il suo lavoro fa parte delle collezioni permanenti del Victoria and Albert Museum, Cooper Hewitt e FRAC. È Professore Emerito del Royal College of Art, dopo aver diretto il dipartimento di architettura dal 1995 al 2011.

Architect, designer and author, born in 1949. He studied at Nottingham University and then with the Architectural Association. A radical architect, he sees the city as a living being. In 1984 he published the manifesto–magazine “NATO” [Narrative Architecture Today]. Art and literature play an important part in many of his designs. Coates has designed and made interiors, shows and buildings around the world. These include: Caffè Bongo, The Wall, Noah’s Ark and Art Silo in Japan; the National Centre for Popular Music [today The Hub], Powerhouse::uk and the Geffrye Museum in the UK. In his eclectic career, he has also made experimental designs for art and design events, such as Ecstacity, 1992, Architectural Association; Mixtacity, 2007, Tate Modern; Hypnerotosphere, 2008, XI Biennale di Architettura in Venice, 2008. He also designed products for Alessi, AV Mazzega, Ceramica Bardelli, Frag, Fratelli Boffi, Poltronova, Slamp and Varaschin. His work is hosted in the permanent collections of the Victoria and Albert Museum, Cooper Hewitt and FRAC. He is Professor Emeritus at the Royal College of Art, after having led the architecture department there from 1995 to 2011.

Autostrada

Autostrada

Autostrada

Autostrada

Autostrada

Autostrada

Autostrada

Autostrada

Autostrada

Autostrada

Autostrada

Autostrada

Autostrada

Autostrada

Autostrada

Autostrada

Autostrada

Autostrada

Autostrada

Autostrada

Autostrada

Autostrada

Autostrada

Autostrada

Autostrada

Autostrada

Autostrada

Autostrada

Autostrada

Autostrada

Autostrada

Autostrada

Autostrada

Autostrada

Autostrada

Autostrada

Autostrada

Autostrada

Autostrada

Autostrada

Autostrada

Autostrada

Autostrada

Autostrada

Autostrada

Autostrada

Autostrada

Autostrada

Autostrada

Autostrada

Autostrada

Autostrada

Autostrada

Autostrada

Autostrada

Autostrada

Autostrada

Autostrada

Autostrada

Autostrada

Autostrada

Autostrada

De Pas, D’Urbino, Lomazzi

Nel 1966 nasce lo Studio De Pas, D’Urbino, Lomazzi. L’architetto De Pas è mancato nel 1991. Negli anni Sessanta e Settanta lo studio sviluppa con particolare interesse un’attività di creazione di mobili ed architetture temporanee, caratterizzata dall’uso di segni, materiali e tecnologie industriali avanzate, per esempio strutture pneumatiche per la Triennale di Milano, e partecipa, con opere e allestimenti, a numerose mostre di settore. Dagli anni Settanta e Ottanta realizza edifici industriali e residenziali ottenendo numerosi premi e riconoscimenti. Le opere dei tre architetti sono presenti nelle collezioni di design di vari musei tra i quali: il MoMA e il Brooklyn Museum di New York, il Victoria and Albert Museum di Londra, i Kunstgewerbemuseum di Berlino e Zurigo, il Centro Pompidou di Parigi, il Museo del Design della Triennale di Milano. All’attività progettuale uniscono quella teorica e culturale: la docenza al Politecnico di Milano, dal 1999 al 2008, e all’Università IUAV di Venezia dal 2005. L’archivio dello studio, dichiarato di interesse storico particolarmente importante dal Ministero per i Beni e le Attività Culturali, è stato donato nel 2010 al Centro di Alti Studi sulle Arti Visive del Comune di Milano. Il gioco e la regola è il titolo della mostra monografica che la Triennale di Milano ha dedicato allo studio nel 2012.

Studio De Pas, D’Urbino, Lomazzi was set up in 1966. The architect De Pas died in 1991. In the 1960s and ’70s, the studio focused especially on creating temporary furniture and architecture, featuring the use of advanced signs, materials and industrial technologies, for example pneumatic structures for the Milan Triennale, and took part, with works and installations, in many shows in this field. From the 1970–80s on, the studio has been making industrial and residential buildings, obtaining many awards and acknowledgements. Works by the three architects can be found in the design collections of several museums, including: the MoMA and the Brooklyn Museum in New York, the Victoria and Albert Museum in London, the Kunstgewerbemuseum in Berlin and Zurich, the Centre Pompidou in Paris, the Museo del Design of the Milan Triennale. Design work is accompanied by theoretical and cultural work: teaching at the Milan Politecnico University, from 1999 to 2008, and at the IUAV University in Venice since 2005. The archives of the studio, declared to be of especially important historic interest by the Ministry of Cultural Heritage and Activities, were donated in 2010 to the Centro di Alti Studi sulle Arti Visive of the Municipality of Milan. Il gioco e la regola was the title of the monographic show the Milan Triennale dedicated to the studio in 2012.

Studio De Pas, D’Urbino, Lomazzi was set up in 1966. The architect De Pas died in 1991. In the 1960s and ’70s, the studio focused especially on creating temporary furniture and architecture, featuring the use of advanced signs, materials and industrial technologies, for example pneumatic structures for the Milan Triennale, and took part, with works and installations, in many shows in this field. From the 1970–80s on, the studio has been making industrial and residential buildings, obtaining many awards and acknowledgements. Works by the three architects can be found in the design collections of several museums, including: the MoMA and the Brooklyn Museum in New York, the Victoria and Albert Museum in London, the Kunstgewerbemuseum in Berlin and Zurich, the Centre Pompidou in Paris, the Museo del Design of the Milan Triennale. Design work is accompanied by theoretical and cultural work: teaching at the Milan Politecnico University, from 1999 to 2008, and at the IUAV University in Venice since 2005. The archives of the studio, declared to be of especially important historic interest by the Ministry of Cultural Heritage and Activities, were donated in 2010 to the Centro di Alti Studi sulle Arti Visive of the Municipality of Milan. Il gioco e la regola was the title of the monographic show the Milan Triennale dedicated to the studio in 2012.

Studio De Pas, D’Urbino, Lomazzi was set up in 1966. The architect De Pas died in 1991. In the 1960s and ’70s, the studio focused especially on creating temporary furniture and architecture, featuring the use of advanced signs, materials and industrial technologies, for example pneumatic structures for the Milan Triennale, and took part, with works and installations, in many shows in this field. From the 1970–80s on, the studio has been making industrial and residential buildings, obtaining many awards and acknowledgements. Works by the three architects can be found in the design collections of several museums, including: the MoMA and the Brooklyn Museum in New York, the Victoria and Albert Museum in London, the Kunstgewerbemuseum in Berlin and Zurich, the Centre Pompidou in Paris, the Museo del Design of the Milan Triennale. Design work is accompanied by theoretical and cultural work: teaching at the Milan Politecnico University, from 1999 to 2008, and at the IUAV University in Venice since 2005. The archives of the studio, declared to be of especially important historic interest by the Ministry of Cultural Heritage and Activities, were donated in 2010 to the Centro di Alti Studi sulle Arti Visive of the Municipality of Milan. Il gioco e la regola was the title of the monographic show the Milan Triennale dedicated to the studio in 2012.

Studio De Pas, D’Urbino, Lomazzi was set up in 1966. The architect De Pas died in 1991. In the 1960s and ’70s, the studio focused especially on creating temporary furniture and architecture, featuring the use of advanced signs, materials and industrial technologies, for example pneumatic structures for the Milan Triennale, and took part, with works and installations, in many shows in this field. From the 1970–80s on, the studio has been making industrial and residential buildings, obtaining many awards and acknowledgements. Works by the three architects can be found in the design collections of several museums, including: the MoMA and the Brooklyn Museum in New York, the Victoria and Albert Museum in London, the Kunstgewerbemuseum in Berlin and Zurich, the Centre Pompidou in Paris, the Museo del Design of the Milan Triennale. Design work is accompanied by theoretical and cultural work: teaching at the Milan Politecnico University, from 1999 to 2008, and at the IUAV University in Venice since 2005. The archives of the studio, declared to be of especially important historic interest by the Ministry of Cultural Heritage and Activities, were donated in 2010 to the Centro di Alti Studi sulle Arti Visive of the Municipality of Milan. Il gioco e la regola was the title of the monographic show the Milan Triennale dedicated to the studio in 2012.

Studio De Pas, D’Urbino, Lomazzi was set up in 1966. The architect De Pas died in 1991. In the 1960s and ’70s, the studio focused especially on creating temporary furniture and architecture, featuring the use of advanced signs, materials and industrial technologies, for example pneumatic structures for the Milan Triennale, and took part, with works and installations, in many shows in this field. From the 1970–80s on, the studio has been making industrial and residential buildings, obtaining many awards and acknowledgements. Works by the three architects can be found in the design collections of several museums, including: the MoMA and the Brooklyn Museum in New York, the Victoria and Albert Museum in London, the Kunstgewerbemuseum in Berlin and Zurich, the Centre Pompidou in Paris, the Museo del Design of the Milan Triennale. Design work is accompanied by theoretical and cultural work: teaching at the Milan Politecnico University, from 1999 to 2008, and at the IUAV University in Venice since 2005. The archives of the studio, declared to be of especially important historic interest by the Ministry of Cultural Heritage and Activities, were donated in 2010 to the Centro di Alti Studi sulle Arti Visive of the Municipality of Milan. Il gioco e la regola was the title of the monographic show the Milan Triennale dedicated to the studio in 2012.

È tra gli architetti più influenti della seconda metà del XX secolo in Europa. Nel 1956 si diploma all’Accademia delle Belle Arti di Vienna, nel 1958/59 prosegue gli studi all’Illinois Institute of Technology con Mies van der Rohe e, l’anno successivo, al College of Environmental Design, University of California. Lavora presso diversi studi in Svezia e negli Stati Uniti prima di tornare a Vienna dove fonda il proprio studio nel 1964. Con Walter Pichler nel 1967 firma il manifesto Alles ist Architektur [Tutto è architettura] in cui esprime la sua volontà di progettare includendo criteri desunti dal mondo delle arti: dalla progettazione di mobili alla costruzione di case, fino alla pianificazione urbanistica come urban design. Tra i suoi progetti è possibile ricordare il negozio di candele Retti [1965], gioielleria Schullin [1972–1974], il Museo Abteiberg a Mönchengladbach [1972–1982]. La sua attività di insegnamento è costantemente parallela a quella professionale; è professore e, dal 1995 al 1999, preside del dipartimento di architettura dell’Università delle arti applicate di Vienna. Riceve il premio Pritzker nel 1985. Gli anni Ottanta segnano anche la collaborazione con Poltronova per la realizzazione dei divani Mitzi e Marilyn insieme alle commissioni per Alessi, Munari, Memphis M.I.D. e altri. Ha ricoperto il ruolo di direttore della sezione d’architettura della Biennale di Venezia del 1994–1996. Nel 2004 l’American Academy of Arts and Letters gli conferisce l’Arnold W. Brunner Memorial Prize.

He was one of the most influential architects of the second half of the 20th century in Europe. In 1956 he graduated from the Academy of Fine Arts in Vienna, in 1958/59 he continued his studies at the Illinois Institute of Technology with Mies van der Rohe and, in the following year, at the College of Environmental Design, University of California. He worked at various architectural firms in Sweden and the United States before returning to Vienna, where he opened his own practice in 1964. With Walter Pichler in 1967 he signed the manifesto Alles ist Architektur [Everything is Architecture] in which he expressed his desire to design by including criteria taken from the world of the arts: from furniture design to house construction, to urban planning as urban design. His projects include the Retti candle shop [1965], the Schullin jewellery shop [1972–1974], the Abteiberg Museum in Mönchengladbach [1972–1982]. His teaching activity ran parallel to his professional activity; he was a professor and, from 1995 to 1999, dean of the architecture department at the University of Applied Arts in Vienna. He was awarded the Pritzker Prize in 1985. The 1980s also marked his collaboration with Poltronova for the creation of the Mitzi and Marilyn sofas, together with commissions for Alessi, Munari, Memphis M.I.D. and others. He served as director of the architecture section of the 1994–1996 Venice Biennale. In 2004 the American Academy of Arts and Letters awarded him the Arnold W. Brunner Memorial Prize.

Autostrada

Autostrada

Autostrada

Gianni Pettena

Gianni Pettena [Bolzano 1940] è architetto, artista, critico e storico dell’architettura. È stato membro della Global Tools, professore di Storia dell’Architettura Contemporanea all’Università di Firenze, ha insegnato alla California State University di Firenze e all’Architectural Association di Londra. Co–fondatore e ispiratore alla fine degli anni ’60 del movimento dell’Architettura Radicale Italiana, da cui ha avuto origine gran parte della sperimentazione contemporanea nel campo dell’architettura e del design, svolge un lavoro sperimentale volto ad eliminare i confini disciplinari e a rivisitare e reinventare alfabeti e linguaggi attraverso progetti, arredi, installazioni, mostre, scritti teorici, saggi e testi. L’unicità del suo lungo lavoro anche sul piano storico, consiste nel rifiuto dei codici e canoni consueti della progettazione, nella realizzazione di interventi temporanei e in una costante ricerca di alleanze con l’arte concettuale, il Radical design austriaco, la Land Art e la musica sperimentale. Il suo lavoro è stato presentato in musei e istituzioni come la Biennale di Venezia, il Mori Museum di Tokyo, il Barbican Centre di Londra, il Pac di Milano, il Museion di Bolzano, il Frac Centre di Orléans, il Centres Pompidou di Parigi e Metz. Il suo archivio è conservato presso il CCA di Montréal.

Gianni Pettena [Bolzano 1940] is an architect, artist, critic and architectural historian. Was member of Global Tools, professor of History of Contemporary Architecture at the University of Florence, he also taught at California State University of Florence and the Architectural Association in London. Co–founder and inspirer in the late 1960s of the Italian Radical Architecture movement, from which much of the contemporary experimentation in the field of architecture and design originated, he carries out experimental work aimed at eliminating disciplinary boundaries and revisiting and reinventing alphabets and languages through projects, furniture, installations, exhibitions, theoretical writings, essays and texts. The uniqueness of his long career in informed by his rejection of discipline–based roles and methodologies, creating temporary works while constantly seeking alliance with conceptual art, Austrian Radical Design, Land Art and experimental music. His work has been presented in museums and institution such as the Venice Biennale, Mori Museum in Tokyo, Barbican Centre in London, PAC in Milan, Museion in Bolzano, the Frac Centre in Orléans and the Pompidou Centers in Paris and Metz. His archive is housed at the CCA in Montréal.

Franco Raggi

Nato a Milano nel 1945, dove si è laureato in architettura al Politecnico nel 1969. Redattore delle riviste “Casabella” [1971–76] e “MOD0” [1980–83]. Nel 1973 per l’IDZ [Internationale Design Zentrum] di Berlino ha allestito la prima mostra critica sul Design Radicale Italiano. Come autore e progettista ha partecipato a diverse mostre tra le quali: Assenza Presenza [Bologna 1978], Cinquant’anni di architettura italiana [Milano 1979], La neomerce [Milano–Parigi 1985]. Nel 1983 per la XVII Triennale di Milano ha ideato e allestito la mostra Le case della Triennale. Nella XVIII Triennale del 1989 ha ordinato la sezione design nella mostra Il futuro delle metropoli. Nel 2015 ha curato e allestito la mostra Una galleria lunga 40 anni presso l’Ordine degli architetti di Milano. La sua lampada On–Off per Luceplan è presente nella collezione permanente del MoMA di NewYork. Ha progettato oggetti per varie aziende: Fontana Arte, Cappellini, Kartell, Poltronova, Luceplan, Candle, Zeus–Noto, Artemide e Danese. Ha insegnato dal 1989 al 2000 all’Istituto Europeo del Design a Milano. Ha svolto corsi e seminari in Italia presso il Politecnico di Milano e all'estero. Dal 2002 è titolare del corso di Interior Design all’ISIA di Firenze. Vive e lavora a Milano.

Born in 1945 in Milan, where he graduated in architecture at the Politecnico in 1969. Editor of the magazines “Casabella” [1971–76] and “MOD0” [1980–83]. In 1973, for IDZ [Internationale Design Zentrum] in Berlin, he set up the first critical show on Radical Italian Design. As author and designer, he took part in several shows, including: Assenza Presenza [Bologna 1978], Cinquant’anni di architettura italiana [Milan 1979], La neomerce [Milan–Paris 1985]. In 1983, for the 17th Triennale of Milan, he designed and set up the show Le case della Triennale. In the 18th Triennale in 1989, he curated the design section in the show Il futuro delle metropoli. In 2015, he curated and set up the show Una galleria lunga 40 anni at the Chamber of Architects of Milan. His On–Off lamp for Luceplan is hosted with MoMA’s permanent collection in New York. He designed items for various businesses: Fontana Arte, Cappellini, Kartell, Poltronova, Luceplan, Candle, Zeus–Noto, Artemide and Danese. From 1989 to 2000, he taught at Istituto Europeo del Design in Milan. He held courses and seminars in Italy at the Milan Politecnico University and abroad. Since 2002, he has been professor of Interior Design at the Florence ISIA [Higher Institute for Artistic Industries]. He lives and works in Milan.

Rumble

Ultrafragola

Ettore Sottsass jr.

Ettore Sottsass jr. nasce a Innsbruck nel 1917 e si laurea al Politecnico di Torino nel 1939. Nel 1946 inizia la collaborazione alla rivista “Domus” e nel 1947 apre a Milano uno studio professionale di progetti di architettura e design. Nel 1958 diventa consulente di Olivetti con cui vince quattro Compassi d’Oro. A partire dal 1957 e per il successivo ventennio riveste il ruolo di art director per la Poltronova di Agliana, dove creerà tra gli altri la serie dei Mobili Grigi presentati a Eurodomus nel 1970, di cui fa parte Ultrafragola. Proprio la Poltronova sarà terreno privilegiato d’incontro con la più giovane Avanguardia Radicale, tra cui Archizoom Associati, Superstudio, UFO, Gianni Pettena. Tra il 1978 e il 1979 partecipa allo Studio Alchimia, fondato da Alessandro e Adriana Guerriero, primo esempio di progettisti produttori. Nel 1981 fonda Memphis, laboratorio di design e contemporaneamente dà vita alla Sottsass Associati con Zanini, Thun, Cibic, Grawunder con cui realizza architetture in tutto il mondo. Gli anni Novanta sono ricchi di riconoscimenti internazionali tra cui la nomina a Honorary Doctor del Royal College of Art di Londra [1996]. Nei primi anni Duemila viene richiamato dal rinnovato Centro Studi Poltronova per il Design di Roberta Meloni. Nel 2017, centenario della nascita e decennale della morte, gli vengono dedicate in tutto il mondo mostre fondamentali.

Ettore Sottsass jr. was born in Innsbruck in 1917, and graduated from the Turin Politecnico in 1939. In 1946, he started working with the magazine “Domus” and in 1947, he opened a professional office in Milan for architecture and design projects. In 1958, he became a consultant to Olivetti, where he won four Compasso d’Oro. Starting in 1967, for twenty years he was art director for Poltronova in Agliana, where, among other items, he created Mobili Grigi presented at Eurodomus in 1970, which included Ultrafragola. Poltronova would be the privileged place of encounter with the young Radical Vanguard, including Archizoom Associati, Superstudio, UFO, Gianni Pettena. Between 1978 and 1979, he partecipated in Studio Alchimia, founded by Alessandro and Adriana Guerriero, a first example of producer designers. In 1981, he founded the design workshop Memphis, and at the same time set up Sottsass Associati with Zanini, Thun, Cibic, Grawunder, who together made architecture all over the world. The 1990s were rich in international acknowledgement, including the appointment as Honorary Doctor at the London Royal College of Art [1996]. In the first years of the new century, he was called back by Roberta Meloni’s renowned Centro Studi Poltronova per il Design. In 2017, the centenary of his birth and the tenth anniversary of his death, fundamental shows were dedicated to him all over the world.

Superstudio

Superstudio, fondato a Firenze nel 1966 presso la Facoltà di Architettura, è composto inizialmente da Adolfo Natalini e Cristiano Toraldo di Francia, a cui si aggiungono Roberto Magris [dal 1967], Piero Frassinelli [dal 1968], Alessandro Magris [dal 1970] e Alessandro Poli [dal 1970 al 1972]. L’attività sperimentale di Superstudio inizia con la partecipazione alla mostra Superarchitettura [1966] organizzata insieme ad Archizoom. Da quell’esperienza, e grazie all’incontro con Poltronova, nasceranno la lampada Passiflora e il divano Sofo. Tra il 1968 e il 1969 vengono pubblicati Design d’invenzione e design d’evasione [“Domus” 475, 1969], Istogrammi d’architettura [1969] e Monumento continuo. Sempre nel 1969 il gruppo partecipa alla Biennale di Graz avente per tema Architettura e libertà. Tra il 1971 e il 1973 Superstudio produce filmati e progetti utopici: Cinque storie del Superstudio e Supersurface presentato nel 1972 al MoMA di New York in occasione della mostra Italy: The New Domestic Landscape. Nel 1973 è tra i membri della Global Tools presieduta da Ettore Sottsass jr. e nel 1978 partecipa alla mostra Topologia e Morfogenesi alla Biennale di Venezia. Tra i più recenti tributi al gruppo: Superstudio 50 mostra a cura di Gabriele Mastrigli, MAXXI di Roma; Superstudio Migrazioni, CIVA di Bruxelles [2020].

Superstudio, founded in Florence in 1966 at the Faculty of Architecture, initially consisted of Adolfo Natalini and Cristiano Toraldo di Francia, who were later joined by Roberto Magris [in 1967], Piero Frassinelli [in 1968], Alessandro Magris [in 1970] and Alessandro Poli [from 1970 to 1972]. Superstudio’s experimental activity began when it took part in the show Superarchitettura [1966] organised together with Archizoom. That experience, thanks to the encounter with Poltronova, gave birth to the lamp Passiflora and the couch Sofo. Design d’invenzione e design d’evasione [“Domus” 475, 1969], Istogrammi d’architettura [1969] and Monumento continuo were published between 1968 and 1969. Still in 1969, the group took part in the Graz Biennale with the theme Architecture and Freedom. Between 1971 and 1973, Superstudio produced theoretical work, films and utopian designs: Cinque storie del Superstudio and Supersurface presented in 1972 at the New York MoMA during the show Italy: The New Domestic Landscape. In 1973, he was one of the founding members of Global Tools presided by Ettore Sottsass jr. In 1978, before the group broke up, he took part in the show Topologia e Morfogenesi at the Venice Biennale. Some recent tributes to the group include: Superstudio 50, a show curated by Gabriele Mastrigli, MAXXI in Rome; Superstudio Migrazioni, CIVA Brussels [2020].

Canton

Gherpe / Ofelia, Spera, Vanitas / Passiflora / Sofo / To1 / To2

Lella and Massimo Vignelli

Lella Vignelli, all'anagrafe Elena Valle [Udine 1934 – New York 2016], e Massimo Vignelli [Milano 1931 – New York 2014], sono stati uniti per sessanta anni nella vita e nel lavoro. Nel 1957 si sposano, si trasferiscono e lavorano negli Stati Uniti con borse di studio del Massachusetts Institute of Technology, Cambridge, dell'Institute of Design, Illinois. Elena nel 1959 si unisce alla Skidmore, Owings & Merrill, Chicago, come junior designer. Nel 1960 tornano a Milano dove fondano uno studio che si occupa di grafica, corporate identity, disegno industriale. Tra i committenti: Olivetti, Pirelli, Poltronova [gruppo Saratoga 1965–71], Penguin Books, la Triennale di Milano, la Biennale di Venezia, Feltrinelli. Nel 1965 tornano negli Stati Uniti dove contribuiscono alla fondazione di Unimark International, struttura con 10 sedi in 4 continenti, creando progetti iconici come il sistema di segnaletica della metropolitana di New York [1966–70]. Nel 1971 lasciano Unimark e riprendono l'attività professionale indipendente con la fondazione della Vignelli Associates che lavora per alcune delle aziende più prestigiose al mondo. Nel 1973 ricevono l'Industrial Art Medal dell'Istituto Americano degli Architetti, nel 1998 un secondo Compasso d'Oro. Numerose le mostre sulla loro attività e numerosi i musei che conservano i loro oggetti. Il loro archivio è stato donato al Rochester Institute of Technology.

Lella Vignelli, born Elena Valle [Udine 1934 – New York 2016], and Massimo Vignelli [Milan 1931 – New York 2014], lived and worked together for sixty years. In 1957, they got married and moved to work in the USA, with study grants from the Massachusetts Institute of Technology, Cambridge and from the Institute of Design, Illinois. In 1959, Elena joined Skidmore, Owings & Merrill, Chicago, as junior designer. In 1960, they went back to Milan, where they founded an office dealing with graphics, corporate identity, industrial design. Clients included: Olivetti, Pirelli, Poltronova [Saratoga group 1965–71], Penguin Books, the Triennale in Milan, the Biennale of Venice, Feltrinelli. In 1965, they went back to the US, where they shared in founding Unimark International Corporation for Design, an organisation with ten offices in four continents, creating such iconic designs as the New York City Subway signage system [1966–70]. In 1971, they left Unimark and dedicated themselves again to independent professional work, founding Vignelli Associates, which worked for some of the most prestigious businesses in the world. In 1973, they were awarded the Industrial Art Medal of the American Institute of Architects, and in 1998, another Compasso d'Oro. Many shows celebrate their activities and many museums host their items. Their archive was donated to the Rochester Institute of Technology.

Bethan Laura Wood

Bethan Laura Wood gestisce dal 2009 uno studio multidisciplinare caratterizzato dalla ricerca sui materiali, dalla collaborazione artigianale e dalla passione per il colore e il dettaglio. Residenze e progetti basati sul luogo sono diventati un fattore importante nel suo processo di design. Bethan è affascinata dalle connessioni che stabiliamo con gli oggetti quotidiani che ci circondano, esplora queste relazioni e s'interroga su come possano diventare dei veicoli culturali. È interessata agli approcci critici per raggiungere la sostenibilità all'interno del consumo di massa e del contesto dell'industria del design guidato dalla produzione.

Bethan Laura Wood has been running a multidisciplinary studio since 2009, characterised by research into materials, collaborative craftsmanship and a passion for color and detail. Residences and place-based projects have become an important factor in her design process. Bethan is fascinated by the connections we make with the everyday objects around us, exploring these relationships and questioning how they can become cultural vehicles. She is interested in critical approaches to achieving sustainability within the mass consumption and production driven design industry context.

Publicato nel 2024 da Published in 2024 by	Centro Studi Poltronova
Stampato in Printed in	Italia Italy
Direzione artistica Art Direction	Donatello D'Angelo
A cura di Edited by	Elisabetta Trincherini
Progetto grafico Graphic Design	D'Apostrophe
Foto Photography	Serena Eller Vainicher, Benedetta Gori, Pietro Savorelli, Damiano Verdiani
Un ringraziamento speciale a With special thanks to	Cristina Morozzi
Tutti i diritti sono riservati All rights reserved	Nessuna parte di questa pubblicazione può essere riprodotta o trasmessa in qualsiasi forma o con qualsiasi mezzo, elettronico o meccanico, comprese fotocopie, registrazioni digitali o qualsiasi sistema di recupero di informazioni, senza previa autorizzazione del Centro Studi Poltronova per il Design®. No part of this publication may be reproduced or transmitted in any form or by any means, electronic or mechanical, including photocopy, digital recording or any information retrieval system, without prior permission from Centro Studi Poltronova per il Design®.
Avviso sulle immagini pubblicate Warning on published images	La forma, la dimensione e il colore dei prodotti potrebbero essere percepiti in modo leggermente diverso a seconda del tipo di immagine, della luce, dello sfondo o dell'ambiente circostante. Non possiamo garantire che i colori e le sfumature visibili sul nostro catalogo e sito web siano l'esatta riproduzione del colore reale del prodotto, in quanto la qualità della stampa o le impostazioni di ciascuna schermata possono influire sulla percezione visiva. Shape, size and color of the products might be perceived slightly different, depending on the type of picture, the light, the background or the surrounding environment. We cannot guarantee that the colors and the shades seen on our catalogue and website are the exact reproduction of the actual color of the product. It does depend on the quality of the print or the settings of each screen.
Tutti i progetti sono protetti da copyright Copyright exists on all designs	Queste opere sono brevettate in tutto il mondo e conformi ai più importanti standard di qualità e sicurezza. Centro Studi Poltronova si riserva il diritto di modificare il proprio listino prezzi e/o i prodotti senza preavviso nel caso in cui condizioni commerciali lo rendessero necessario. These works are patented throughout the world and conform to leading standards of quality and safety. Centro Studi Poltronova reserves the right to modify its price list and/or products without notice in the event of commercial conditions rendering this necessary.
Qualsiasi richiesta, sia di archivio che commerciale, può essere indirizzata a All enquiries, both archival and commercial, should be directed to	Centro Studi Poltronova per il Design srl via Lorenzo Bartolini 2, 50124 Firenze, Italy www.poltronova.it / info@poltronova.it T +39 055 0241189

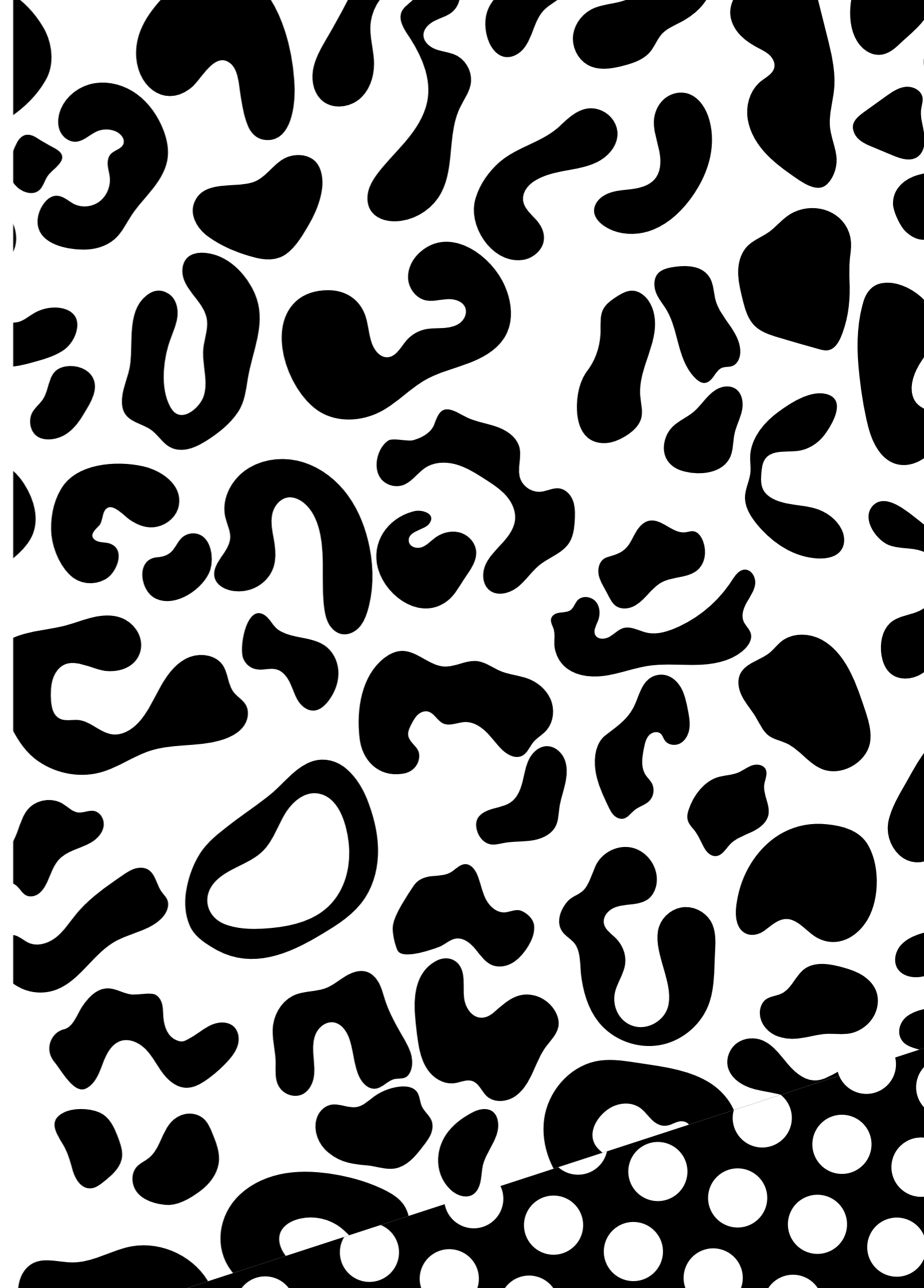

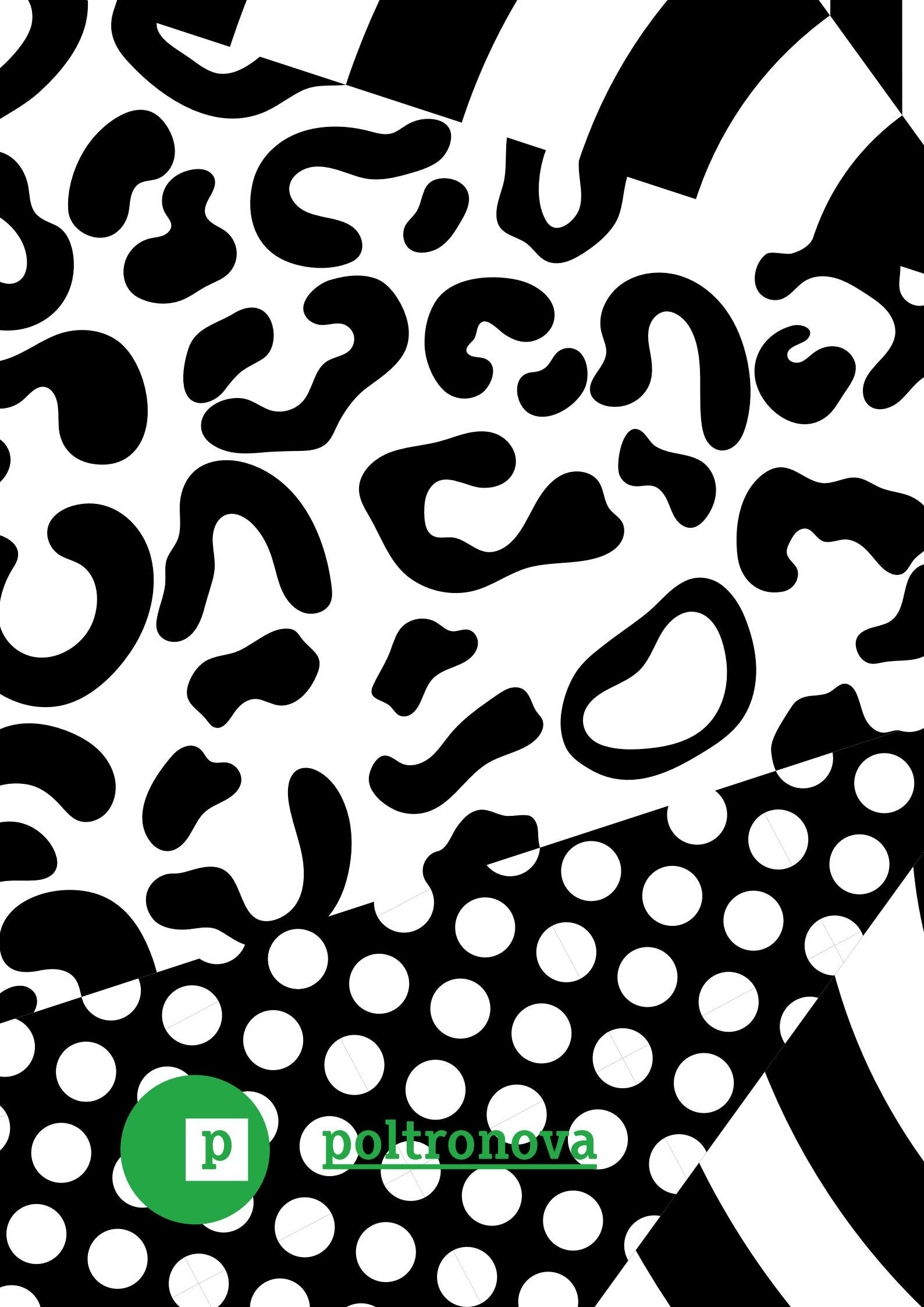

poltronova