

GHIDINI  
1961  
GHIDINI



2024  
Collection

GHIDINI 1961 INIZIATIVE

# 2024 Collection

10\_ **Tasca**\_sofas and armchair

16\_ **Flo**\_sofas and armchair

26\_ **Mambo**\_modular sofa and armchair

32\_ **Tria**\_tables-small tables

40\_ **Spritz**\_small armchairs

42\_ **Artù**\_tables

48\_ **Arch**\_dining chair

50\_ **Merlino**\_tables

54\_ **Hillary**\_dining chair

56\_ **Shaker**\_console

57\_ **Frame**\_console

58\_ **Arnold**\_small tables

60\_ **Dapertutto**\_small tables

62\_ **Helios**\_lamps

64\_ **Buttefly**\_mirror

# The Company

Ghidini1961 of Villa Carcina, in the province of Brescia, belongs to Italy's manufacturing excellence, thanks to their unparalleled production skills.

A specialist in die casting brass, aluminum and steel, the company excels in combining advanced technologies with traditional craft skills. With these solid foundations, the creative team composed by international designers has been able to enhance the properties of metals by creating innovative, timeless products chiseled with all the care for every detail that is distinctive of Ghidini's fine craftsmanship.

In this catalogue, you will come across products destined to become iconic, to erase the boundary between art and design and to establish with the public a communion of intentions and views such as to translate into a loyal and lasting relationship, just like artistic artefacts. A demonstration of how the reliability and quality of a brand can become a warranty of an investment capable of acquiring value over time.



# The craft

The entire production cycle takes place in-house and is characterized by a meticulous attention to detail: from the idea to the end product, passing through the various processing stages – from pressure die casting to lost wax and gravity casting, from machining to drilling, from satin-finishing to sand-blasting and polishing. These are the solid foundations of Ghidini1961.

With over 60 years of history behind it, and an entrepreneurial wisdom that has been handed down from father to son, Ghidini1961 presents furnishings, lamps and home accessories that are true testimonies of great Italian craftsmanship combined with state of the art production technologies, care for materials, aesthetics and attention to detail.

With this foundation, our products are not just meant to decorate a refined environment, but they represent something valuable,

to be cared of, that can be passed over through generations thanks to its intrinsic and long lasting value blended with iconic and timeless design.



# The products

The collection includes works of art, where metal acquires an almost sculptural power, upholstered furniture, dining tables, beds, cabinets and finely chiseled home accessories, bearing witness to Ghidini's obsession for details.

The series embrace almost all articles for use at home, which are interpreted in an unusual and joyful way: from comfy and versatile sectional sofas, to very seductive, almost sculptural upholstered design statements, such as the Abbracci sofa, conceived Lorenza Bozzoli or Stefano Giovannoni's Frame collection, where geometric shapes are softened by the velvety surface of metal to create a sleek collection of sofas, armchairs, dining tables, cabinets, bookshelves and beds.

Casted metal elements have given life also to a series of other iconic products, such as the Shaker sofa and table, with the casted wheel that defines the language, to the brass and leather buckle of the Leisure sofa and armchair.

In its rich variety, the collection is a selection of the most significant contemporary creative expressions, interpreted and enhanced by Ghidini's skillful expertise and ability to interpret metal in all its possible forms.

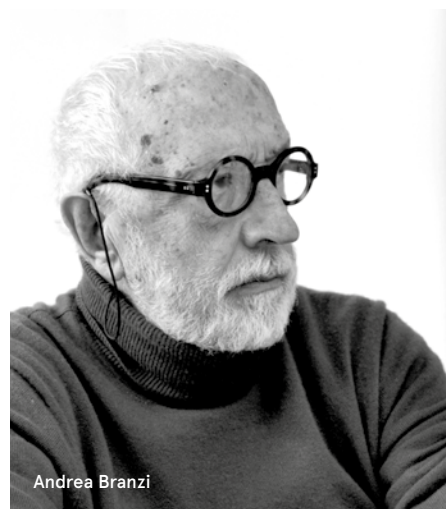

Andrea Branzi

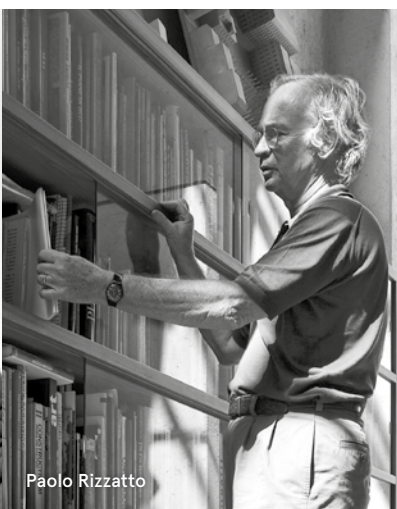

Paolo Rizzatto



Stefano Giovannoni



Lorenza Bozzoli



Robert Stadler



Alessandro Mendini



Aldo Cibic



Richard Hutten



Campana Brothers

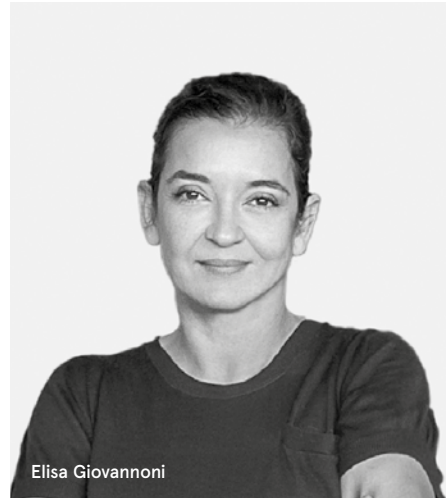

Elisa Giovannoni



Johanna Grawunder



Branch Creative



Noé Duchaufour-Lawrance



Setsu & Shinobu Ito



Tomek Rygalik



Studio Job



Nika Zupanc

# The designers

The brand has put together a diversified creative team able to enhance the properties of metals, in a constant dialogue with precious leathers, fabrics, marbles and woods.

By combining these valuable materials the team has developed a remarkable collection of items, furniture and accessories for daily use. All these products are characterized by innovative design and high quality manufacturing, creating an exclusive mood coherent with the nature and the best tradition of Ghidini1961.

The collection has been designed by renowned international firms such as Aldo Cibic, Alessandro Mendini, Andrea Branzi, Branch Creative, Fernando and Humberto Campana, Noé Duchaufour-Lawrance, Setsu & Shinobu Ito, Johanna Grawunder, Richard Hutten, Elisa Giovannoni, Stefano Giovannoni, Paolo Rizzatto, Tomek Rygalik, Studio Job and Nika Zupanc. The collection ranges from large furniture statements to tiny golden accents that decorate and give warmth to stylish residential environments.

# Tasca

— Sofas and armchair

Robert Stadler

The name Tasca refers to the cushion's elegant leather pockets in which the sofa structure is housed. Both the pockets and the metal parts are reminiscent of distinct equestrian accessories.







# Flo\_\_Sofas and armchair

Lorenza Bozzoli

The Flo series pays homage to mid-20th century Brazilian design, emphasizing high quality materials and comfort such as the use of leather straps to support the seat and backrest. The thick natural leather armchair, padded with goose down, suggests a fusion of luxury, craftsmanship and design.







The back view of the Flo family of seaters emphasizes the dialogue between precious materials, such as casted aluminum, cotton velvet and saddle leather. Customization is once again at the center of the project, thanks to the almost endless combinations between these materials.

The two and four seater sofas are both made with a significant metal structure, typical of the craftsmanship of Ghidini1961. The black cotton velvet provides a strong and distinctive character suitable for both modern and traditional environments. A reinterpretation that fully embraces the principles of contemporary design. The soft armrest suggests an informal interaction with this sofa, reminding that comfort is always a core design element.





# Mambo\_\_Modular sofa

Lorenza Bozzoli

This modular sofa is not simply a piece of furniture but a celebration of the movement, fluidity and expressiveness of the famous Caribbean dance. The sinuous shape allows the sofa to unfold in the space in an elegant way, evoking the graceful and lively movements of mambo dancers.





Each module of the sofa is composed in harmony with the others in a dance that invites you to sit down and let yourself be lulled by its comfort. The color of the chosen velvet recalls the energy and fertility of the tropical land, its generous curls the costumes of Creole dancers.



The Mambo family is completed with a generous and comfy armchair, which shares the same distinctive elements of the large sofa.

The folds and curves of the seat and backrest recall to a convivial language, which blends seamlessly with the large dimensions of the modular sofa.



# Tria

\_Tables/Small tables

Lorenza Bozzoli

Dining table with irregularly shaped top, inspired by the section of a river stone, evokes the fluidity and harmony of nature making it a prominent element in any environment.





Selected for its exceptional quality and color, Portuguese pink marble is renowned for its delicate veins that run across the surface, with nuances that make it unique. The top is supported by zoomorphic sculptured bases made of the same material.



The Tria series also includes coffee tables with triangular tops of three different sizes and heights for numerous compositional possibilities accentuated by the availability of being combined with a wide choice of marbles.





The generous supporting leg of the table allows this family to be offered with sizes up to 280cm. Instead, the coffee tables are offered in three different sizes and heights, allowing very beautiful combinations between different marbles and shapes.



# Spritz\_\_small armchairs

Lorenza Bozzoli

Made up of dining and living armchairs, the Spritz seating family evokes the sparkling world of aperitifs. The 360° swivel movement adds a playful and dynamic element to the armchair, making it perfect for informal environments where conversation and interaction are at the center of the experience. In the dining version, the swivel movement with return allows the seats to return to their always tidy position around the table.



# Artù \_Tables

Paolo Rizzato

The large circular top is well supported by a solid base formed by a series of overlapping concave and convex rotation volumes alternating the metal (brushed burnished metal scots) and stone (grooves and spheres in precious colored marbles).





The whole communicates a feeling of well-constructed stability and security and of noble architectural richness. The circle evokes the legend of the "Knights of the Round Table", and "King Arthur", stone and metal recall the "Sword in the Stone" back to Excalibur.

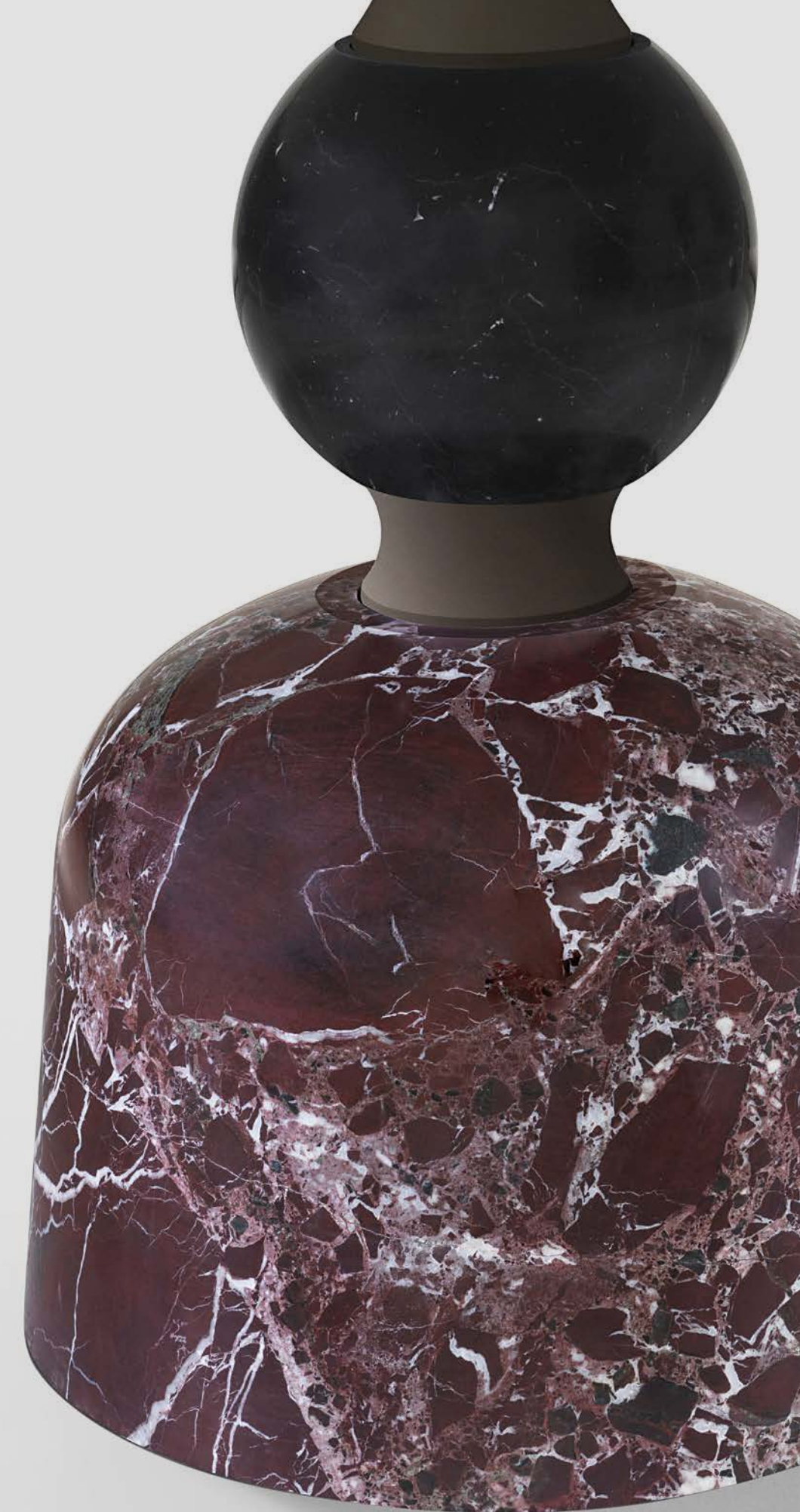



Thanks to the strength and visual presence of the supporting leg, the Artù is presented also in a rectangular and oval configurations. The rectangles are ranging from 200 up to 280cm, and the ovals go up to 200cm in length on a single leg.



# Arch\_Dining chair

Richard Hutten

The Arch chair draws inspiration from the iconic arches of Rome's Colosseum. Its graceful contours and enduring elegance seamlessly marry contemporary style with timeless craftsmanship. Embracing the materiality, the external frame exudes a sense of celebration, while the gentle curves of the backrest promise endless comfort during long evenings. This chair effortlessly infuses richness and sophistication into any space, seamlessly adapting to diverse environments with its versatile charm.



# Merlino\_\_Tables

Paolo Rizzato

The marble top instead seems to float supported by an unusual structure surprisingly rich and light, airy and iridescent as the points of view change. The linear and curvilinear shapes in burnished and brushed metal that compose it they refer to organic vegetal forms and when reflected in a mirrored surface they multiply and they seem to mysteriously sink in the floor plane.



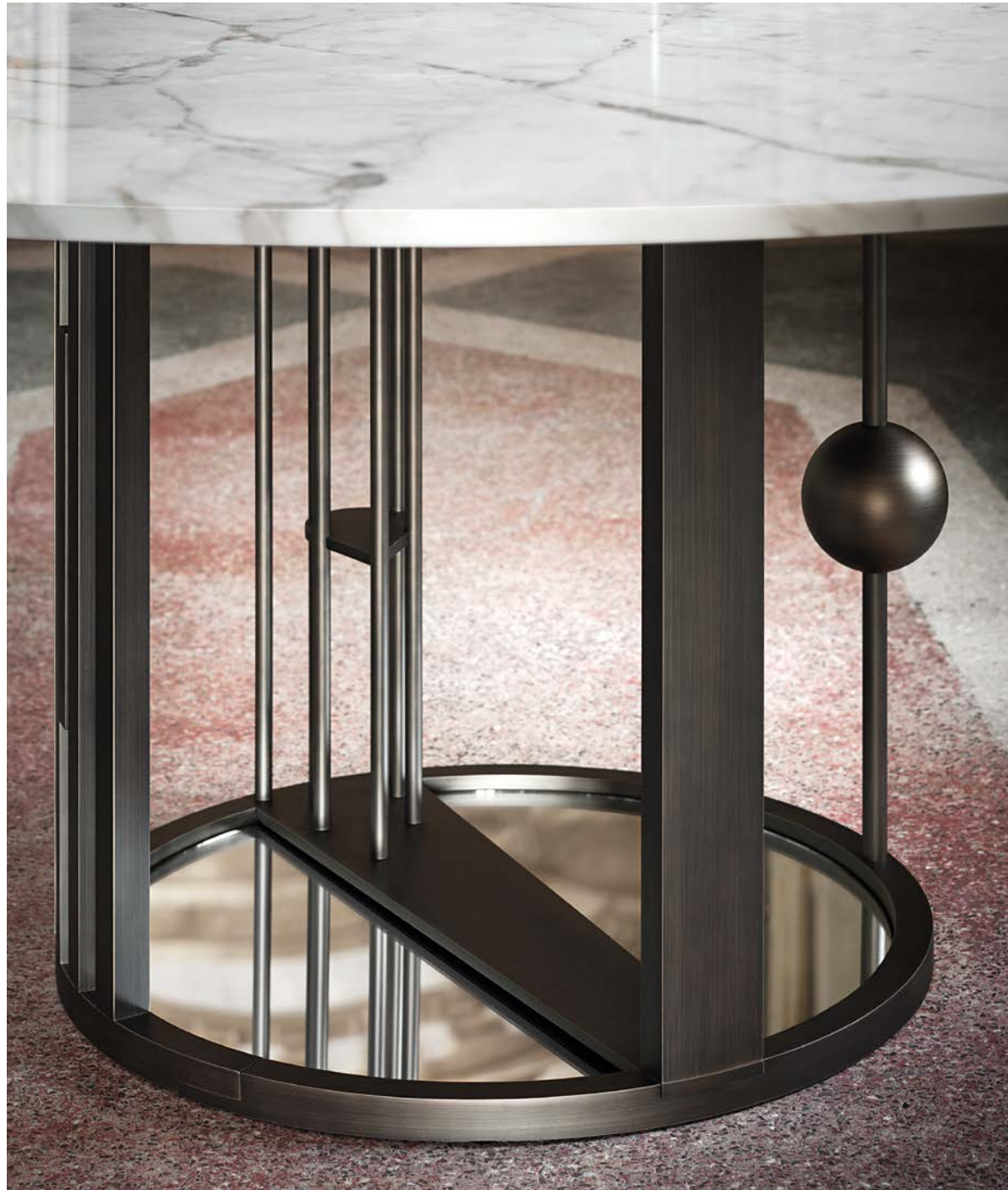

# Hillary

\_Dining chair

Richard Hutten

The Hillary chair, named after the butler of Lara Croft in Tomb Raider, serves you in a very elegant way. The generous proportions of the backrest gives the chair its presence, while at the same time providing high comfort, like a tailor made jacket. With its sleek design, impeccable craftsmanship, and innovative features, it infuses sophistication and opulence into any space. Through a shared dedication to quality, this extraordinary furniture piece emerges as a timeless masterpiece.



# Shaker\_\_Console

Stefano Giovannoni

Family of consoles in different sizes, a classic object wisely redesigned to bring it back to a contemporary dimension. The elegant metal wheel that characterizes the sofa is proposed here as the end of the sinuous turned legs, allowing the console to be moved. The Shaker console is made of cherry wood or matt black lacquered wood.



# Frame\_\_Console

Stefano Giovannoni

Frame is a collection composed of sofas, armchairs, dining tables, consoles and coffee tables, bookshelves, cabinets and beds. Everything starts from a simple element: "the joint", which, combined with elegant rounded 45 degrees extrusions, creates an almost infinite family.



# Arnold\_\_Small tables

Paolo Rizzato

Three geometric shapes (a Line, a Plan, a Volume) and three materials (Metal, Wood, Marble) exploiting the artifice and techniques of "tapering" take the form of: a solid tapered column (in two heights) completed with connections at the base and at the head providing a comfortable support surface characterized by a thin rounded edge and a stable truncated cone base. The several combinations of the three geometries and

the three materials are enriched by some dimensional variations and, with the study and fine-tuning of their overall proportions, take their definitive and complete form where the elegant brass column, which draws and solves the connection and attachment between the top and the base, becomes the distinctive element of the project without taking over the other elements that take part in the compositional game.



# Dapertutto

\_\_Small tables

Paolo Rizzato

"Dapertutto" is a disturbing character, part magician and part devil from "The Tales of Hoffmann", Offenbach's opera fantastique. "Dapertutto" could be the perfect name for this side table designed to sneak "everywhere", in every environment with its form that is both archetypal (think of the Diablo game) and very contemporary (reminiscing black holes), but still ambiguous and reversible.



# Helios\_Lamps

Branch Creative

With this year collection we present an evolution of the Helios family of lights: the lamps are presented with new handmade finishes in polished silver and black finishes. The iconic blown glass lampshade now fully hides the lighting source when switched off.



# Butterfly\_Mirror

Richard Hutten

Butterflies have been a source of inspiration through Art History. From the ancient Egypt's, to the Renaissance until now it has always been a theme. The Butterfly mirror is both playful and elegant.



**68**\_Materials collection  
**92**\_Technical specifications

# Metal finishes

All our finishes are handmade, and all surfaces are lacquered to provide a long lasting durability



Polished brass PB - Cat. A



Chrome CH - Cat. A



Satin Platinum SP - Cat. B



Orbital Bronze OB - Cat. B



Satin brass SB - Cat. B



Light burnished brass LB - Cat. B



Satin Titanium ST - Cat. B



Brushed Copper BC - Cat. B



Dark burnished brass DB - Cat. B



Black Gold BG - Cat. B

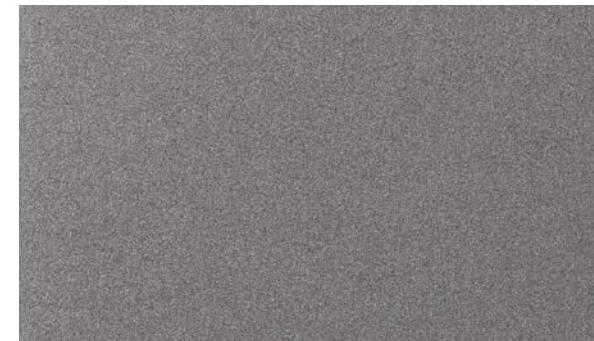

Deep Anthracite DA - Cat. C

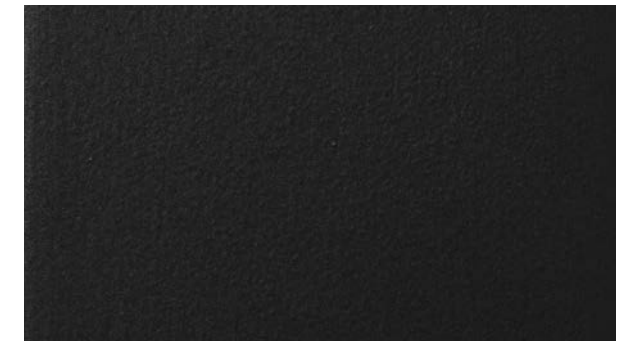

Deep Dark DD - Cat. C



Brown burnished brass BB - Cat. B



Brushed Silver BS - Cat. B

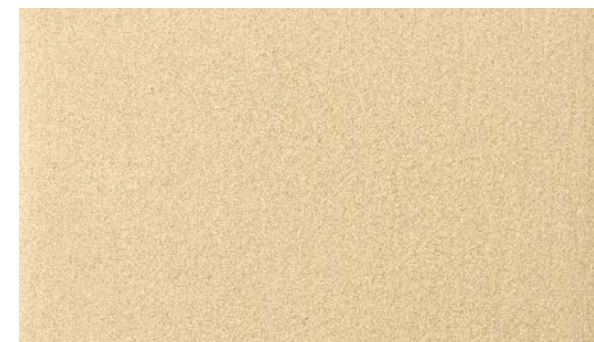

Deep Gold DG - Cat. C



Deep Silver DS - Cat. C

# Marbles Collection



Calacatta Gold CG - Cat. A



Calacatta Purple CP - Cat. A



Classic Travertine TC - Cat. C

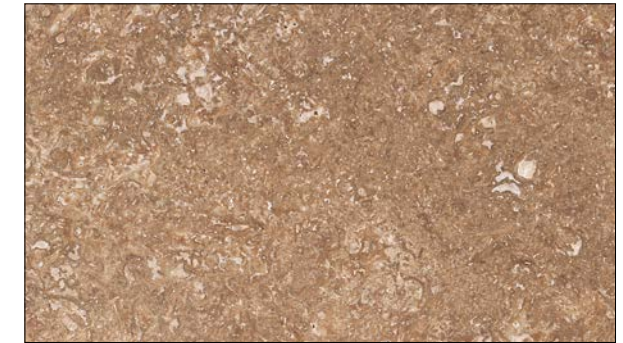

Travertine Walnut TW - Cat. C

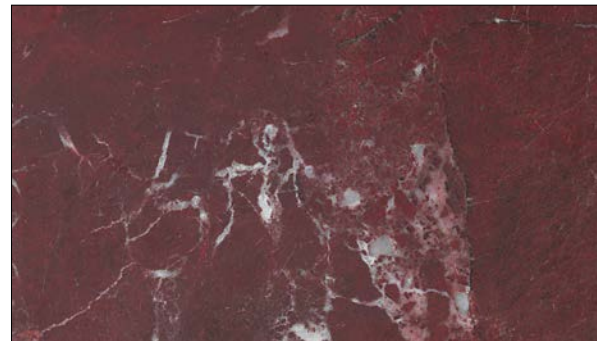

Rosso Levanto RL - Cat. A



Portuguese Rose PR - Cat. A

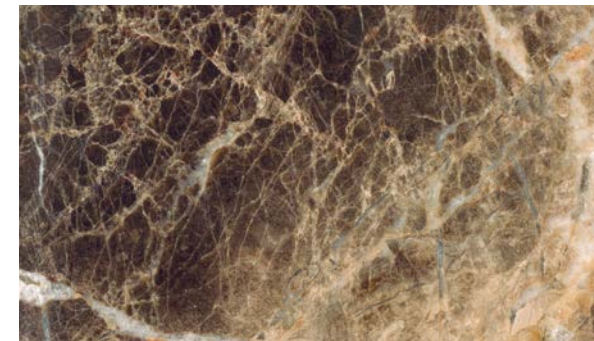

Emperador Dark ED - Cat. C



Carrara White CW - Cat. C



Fior di pesco FP - Cat. B



Yellow Siena YS - Cat. B



Verde Alpi VA - Cat. C



Black Marquina BM - Cat. C



Sahara Noir SN - Cat. B



Red Travertine TR - Cat. B

# Woods Collection



Natural Oak



Bolivar



Canaletto Walnut



Mahogany



New Lime



Caleido

# Adamo&Eva

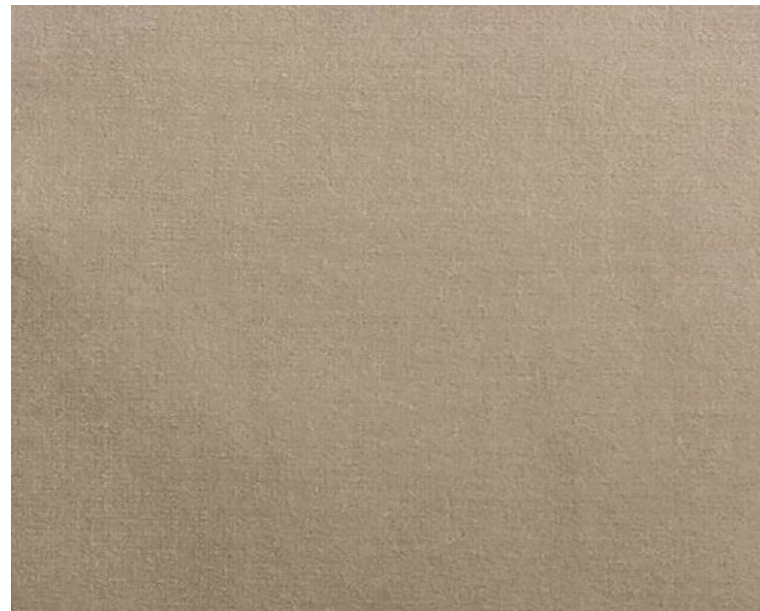

129 - roccia

**Category**  
Cotton Velvet

**Composition**  
100%CO  
Weight: g/ml 630  
Width: cm 140 - 55.12 inches  
Cfa: Yes  
Martindale: 50.000

**Price Category A**

**Washing Instructions**

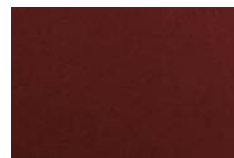

116 - cayenne

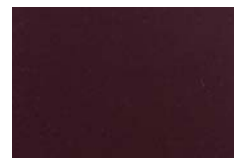

119 - prugna

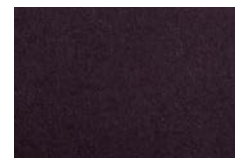

106 - mirtillo

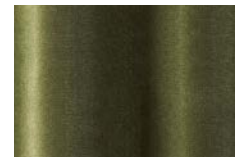

168 - mousse



145 - olive

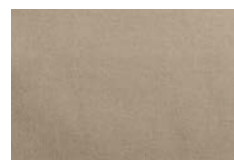

129 - roccia

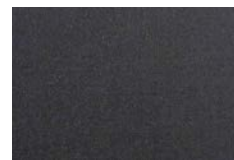

107 - antracite



169 - cactus



104 - indigo



170 - notte



175 - fumo

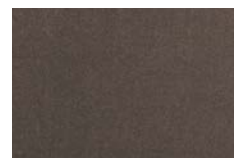

137 - cenere

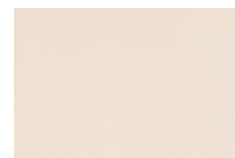

178 - ostrica



115 - safran



189 - verde inglese

An exquisite quality of Italian-made cotton velvet that is soft, versatile and hard-wearing. A palette of 13 colours comprising striking, traditional and neutral shades.

# Cord



053

**Category**  
Cotton Velvet

**Composition**  
100% cotton, groundmaterial: 100% cotton  
Width: 140 cm  
Durability: 100 000 Martindale

**Price Category A**

**Washing Instructions**



053



070



064



050

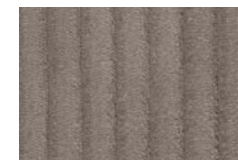

091

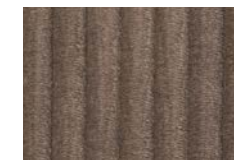

020

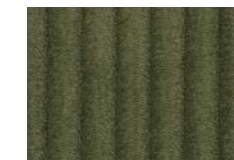

037



060



033



038

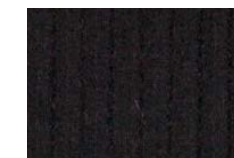

099

# Bogardine



003 - perla



001 - quasinerio



002 - taupe



003 - perla



004 - naturale

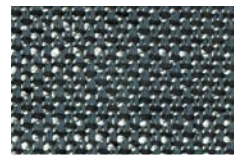

008 - ottanio



009 - bianco

**Category**  
Jacquard

**Composition**  
31%CV 26%CO 24%PAN 10%LI 8%WO 1%PA  
Weight: g/ml 960  
Width: cm 140 - 55.12 inches  
Curtain, Upholstery For Medium/Hard Use  
Cfa: Yes  
Martindale: 40.000

**Price Category** B

**Washing Instructions**



# Clay



0010



002



005



0010



009

**Category**  
Upholstery

**Composition**  
76% Linen, 21% Cotton, 3% Polyester  
Pattern: Solid  
Weight: 770 g/lin.m  
Width: 140 cm  
Durability: 45.000 Martindale  
Pilling: 4  
Lightfastness: 5

**Price Category** B

**Washing Instructions**

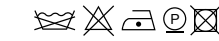

Yarns of different types and thicknesses create a textural weave and confer a slight matelassé effect to the surface. Soft and consistent to the hand, hardwearing and ideal for heavy duty seating.

Bringing together both natural beauty and a sense of finesse, the creative team have mixed colours of yarn in warp and weft to create an elegant yet casual fabric. The result has a unique structured surface that adds an extra dimension to any interior design scheme. With a back cloth that gives extra stability, Clay is perfect for upholstering furniture. The colours are inspired by the designer's love of both art and interiors and include cool shades of cement, blue, and salvia but also the natural shades of wood and clay.

# Clunis



002

**Category**  
Bouclé

**Composition**  
33%WO-25%PL-25%PC-15%CO-2%PA  
Width: 137 cm+/- 3%  
Weight: 4935 gr/ml - 682 gr/sqm +/- 5%  
Martindale: 40000 cycles+/-

**Flame resistance**  
BS 5852-1 (1979) CIGARETTE  
BS 5852:2006 CIGARETTE  
BS 5852-1 (1979) MATCH  
BS 5852:2006 MATCH  
CAL TB 117:2013

**Price Category B**

**Washing Instructions**



002



006



026



000



029



030

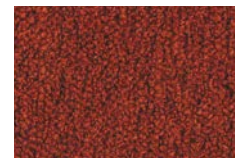

025

# Lizza

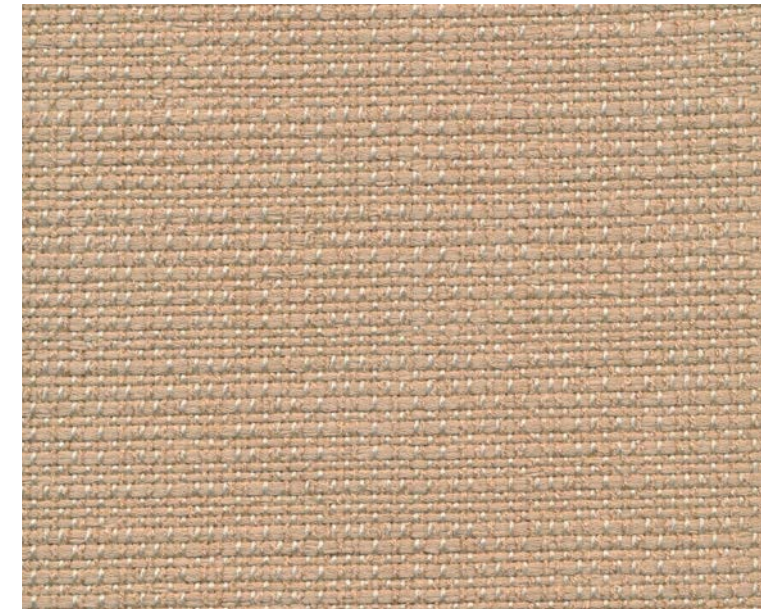

011

**Category**

**Tape Yarn fabric**

**Composition**  
68%VI-29%CO-3%LI  
Width: 140 cm+/- 3%  
Weight: 1000 gr/ml - 714 gr/sqm +/- 5%  
Abrasion Martindale: 25000 cycles+/- 10%

**Flame resistance**  
BS 5852-1 (1979) MATCH

**Price Category B**

**Washing Instructions**

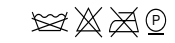

030



121

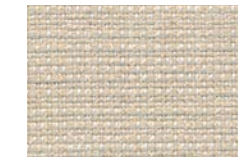

120



092



011



070



043

# Safire



003

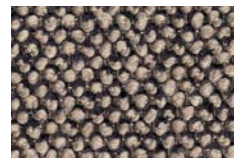

003



004

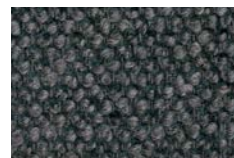

010



008

## Category

Boucle and chenille

## Composition

43% Viscose, 17% Acrylic, 15% New wool, 9% Cotton, 8% Linen, 8% Polyester  
 Weight: 1010 g/lin.m  
 Width: 140 cm  
 Durability: 44 000 Martindale  
 Pilling: 3  
 Lightfastness: 6  
 Sustainability: Greenguard Certification

## Price Category B

## Washing Instructions



# Sinequanon

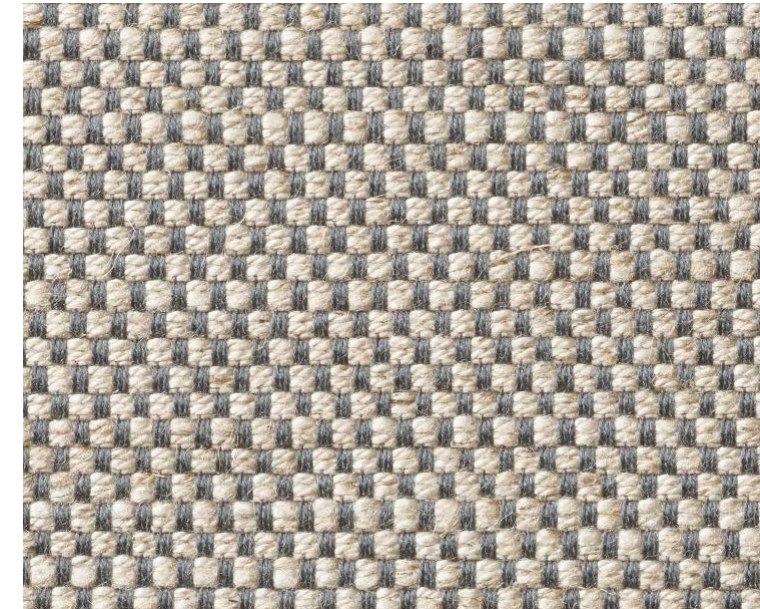

01 - argento



01 - argento



02 - taupe

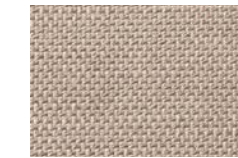

05 - stone



07 - perla



37 - caffè arabica



08 - linen

## Category

Linen and Viscose fabric

## Composition

60%CV 16%LI 13%CO 6%PES 5%PAN  
 Weight: g/ml 663  
 Width: cm 140 - 55.12 inches  
 Cfa: Yes  
 Martindale: 35.000

## Price Category B

## Washing Instructions



Panama weave with slightly shot yarns. Even here the Dedar offer extends with the linen and viscose cloth, which is durable, bright, boasts a rich texture (Flair, Fifty Fifty, Chambray, Aut Aut, Arbus). A special, careful blend of linen and viscose and a new construction which enables a reduction of the textile weight whilst guaranteeing the aesthetic quality, usage and durability, and also offering good value. This textile, just like the others in this range, feature a waterrepellent treatment which offers specific protection from liquids and oils.

# Twiltwenty



4 - cipria

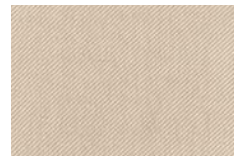

4 - cipria

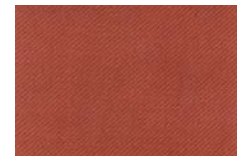

20 - ruggine



7 - nero

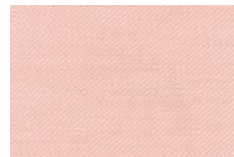

9 - pesco



3 - corda

## Category

Twill

## Composition

100%PI Flame Retardant  
 Width: 140 Cm  
 Weight: 630 Gr  
 Made in: Italy  
 Martindale: 80000  
 Pilling: 4/5 (Scale 1-5)  
 Colour Fastness To Light: 7 (Scale 1-8)  
 Colour Fastness To Crocking: 4/5 Dry 4/5 Wet (Scale 1-5)  
 Colour Fastness To Chlorinated Water: 4/5 (Scale 1-5)  
 Colour Fastness To Sea Water: 4/5 (Scale 1-5)  
 Tensile Strength: Class A (En 14465)  
 Tear Strength: Class A (En 14465)  
 Seam Slippage: Class A (En 14465)  
 Other Certifications: Yarns Certified Oeko-Tex  
 Fire Certifications: France M1 Nfp902-503-504-505, Germany B1 Din 4102-1, Imo 8 Upholstery, Italia Classe 1 Tendaggi, Uk Cigarette Source 0, Uk Contract Curtains Bs5867, Uk Contract Upholstery Bs7176, U.s.a. Cal Tb117

## Price Category B

## Washing Instructions

# Bonsai



020



021



093



072



051



050



070

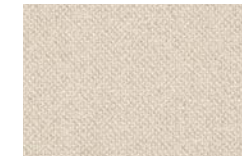

071

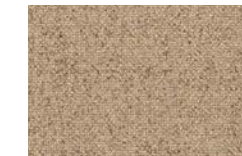

077

## Category

Upholstery

## Composition

48% PAN 29% CO 23% PES  
 Weight: 140 cm  
 Width: 905 per linear meter/g  
 Width: 646 per square meter/g  
 Durability: 50 000 Martindale  
 Seam slippage: <6mm  
 Pilling (DIN EN ISO 12945-2)  
 Rub fastness: Dry 4-5 Wet 4-5  
 Lightfastness: for medium colours 5

## Flame retardent

BS 5852: Part 1: 1979  
 Ignition source 0 (Cigarette)

## Fabric

Wave Dobby

## Price Category C

## Washing Instructions

A classic twill. A particularly thick thread/yarn highlights the "Z" diagonal motif which makes the fabric more dynamic. The shiny and matt threads enhance the effect of the light on the surface.

# Diago



500

### Category

Multi-Yarn Jacquard

### Composition

37%CO-55%VI-8%LI

Width: 140 cm +/- 3%

Weight: 950 gr/ml - 679 gr/sqm +/- 5%

Abrasion Martindale: 27000 cycles +/- 10%

### Flame resistance

BS 5852-1 (1979) MATCH

### Price Category C

### Washing Instructions



500

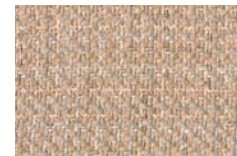

510



511



530



520

# Sofi



187-101

### Category

Cotton and viscose frisé

### Composition

46%CO-47%VI-7%LI

Width: 850 gr/ml - 607 gr/sqm +/- 5%

Weight: 850 gr/ml - 607 gr/sqm +/- 5%

Martindale: 27000 cycles +/- 10%

### Flame resistance

BS 5852:2006 CIGARETTE

BS 5852-1 (1979) MATCH

BS 5852:2006 MATCH

### Price Category C

### Washing Instructions

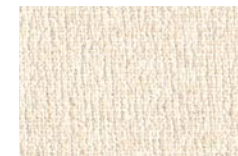

187-101



187-000



187-100



187-029



187-090



187-062

# Kairos collection



1716 - doeskin

**Category**

Nabuck leather

**Composition**

Bovine of European origin in Nabuk finishing, natural grain.  
 The average size of each skin is around 5.0 sqm. Chrome tannage.  
 Aniline dyed, finished with high quality oils. Suede look, soft and velvet touch.  
 The possible presence of any imperfections testify the authenticity and the natural look of pure aniline leather.  
 Average thickness 1,2 - 1,4 mm.

**Price Category A**

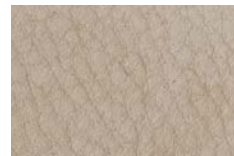

1719 - kangaroo

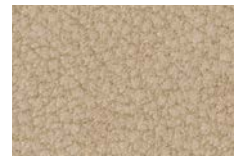

1716 - doeskin

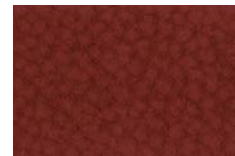

1714 - lucky

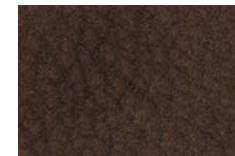

1704 - chocolate forest



1701 - caqui



1711 - cenere



1721 - ematite



1715 - elephant

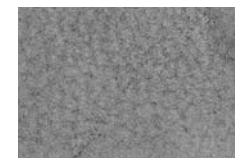

1710 - plomo

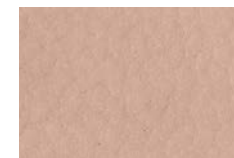

1718 - nude

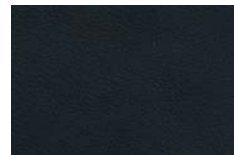

1



5

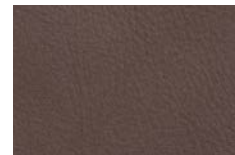

6



7

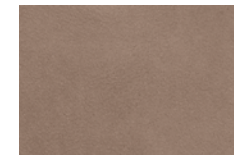

20

# Tivano



3611 - corda

**Category**

European cattle

**Composition**

Raw material: European cattle  
 Tanning: Mineral  
 Protection: Semianiline  
 Description: Waxed hand buffed  
 Thickness: 1,2 - 1,4 mm  
 Average size: 5,0 m<sup>2</sup>

Dry finishing locking	EN ISO 11644	≥ n.a. N/cm
Tear resistance	EN ISO 3377-1	≥ 20 N/cm
Flexing endurance	EN ISO 5402	≥ 20.000 runs
Dry rub colour fastness	EN ISO 11640	
	150 runs	≥ 4 grey scale
Wet rub colour fastness	EN ISO 11640	
	25 runs	≥ 4 grey scale
Light fastness	EN ISO 105-B	≥ 4 blue scale
Heat colour fastness	EN ISO 17228	≥ 4 grey scale

Avoid exposure to direct sunlight and heat sources  
 Clean frequently and gently with a soft cloth  
 Remove stains with a damp cloth or with a specific cleaning product

**Price Category A**



3611 - corda



3606 - tobacco



3603 - militare



3612 - fumo

# Aida collection



Daino

**Category**

Nappa Smooth leather

**Composition**

Average size 4.5-4.8 sqm, thickness 0.9-1.1 mm.

Chrome tannage.

Bovine leather with smooth aspect, aniline finished with some oils and waxes, produced on European bull.

Aniline dyed, finished with high quality oils. Soft article with a slight two tones effect, emotional touch.

The possible presence of any imperfections and color variations are typical for this type of leather as they testify the authenticity and the natural look of pure aniline leather.

**Price Category B**



Daino

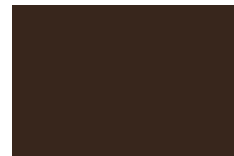

Coffee



Tan



Saddle

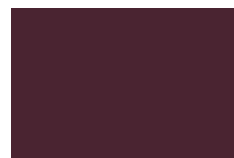

Blackberry

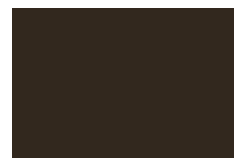

Spruce



Nocturne



Mud



Grey



Sand

# Freddie collection



2

**Category**

High quality bovine leather with full natural grain

**Composition**

Bovine of European origin, finished thickness 1.4 mm.

Flammability of fabrics – Upholstered furniture for maritime use – IMO FTPC 8 (par. 7,2-7,3)

Flammability of fabrics – Upholstered furniture BS 5852-1:1979 (Crib 0 – Crib 1)

Flammability of fabrics – TB 117:2013

Resistance to bending

UNI EN ISO 5402-1 > 50,000 cycles – unaltered

**Price Category B**



2

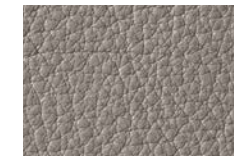

3



6

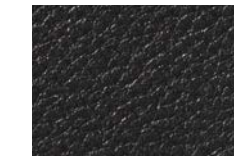

8

# Linea collection



647 - grigio perla

### Category

High quality bovine leather with lightly buffed natural grain

### Composition

Bovine of European origin, lightly buffed natural grain, finished thickness 0.9 - 1.1 mm.

The average size of each hide is around 4.8 - 5.0 sqm. Chrome tannage.

Through dyed; finishing with resins and pigments. Article with a pigmented and protective coat, with a soft, waxy feel and semi-matt appearance.

### Price Category C

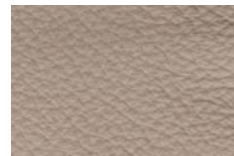

629 - stone

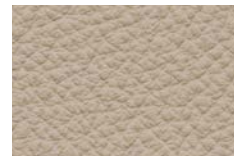

647 - grigio perla



677 - malt



660 - asfalto



675 - new grey

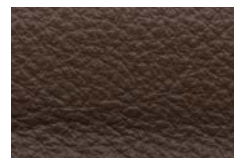

612 - castagna

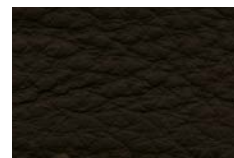

611 - testa moro



656 - cotto

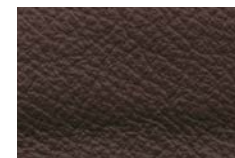

610 - mogano

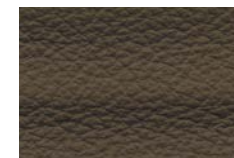

632 - verdone

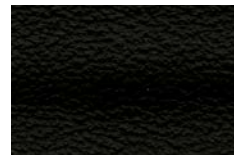

622 - nero



619 - giallino

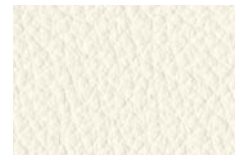

634 - gesso



674 - octane

# Cuoio Leather

Only for Frame and Flo family of seaters



naturale

### Composition

Bovine of European origin in Nabuk finishing, natural grain.

Average thickness 1.8/2.0 mm. Chrome tannage.

Aniline dyed with pigmented finish.

The possible presence of any imperfections testify the authenticity and the natural look of pure cuoio leather.



avorio

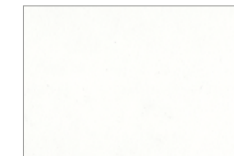

bianco



grigio



naturale



nero

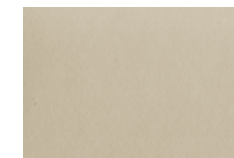

nocciola



rosso bulgaro



sabbia

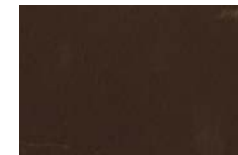

tabacco



testa di moro

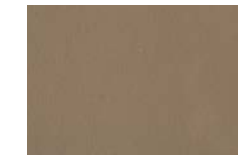

tortora



verde fango

# Tasca

Sofas and armchair\_Robert Stadler

## Structure

Internal structure in plywood panel and polyurethane rubber covered in fabric or leather.

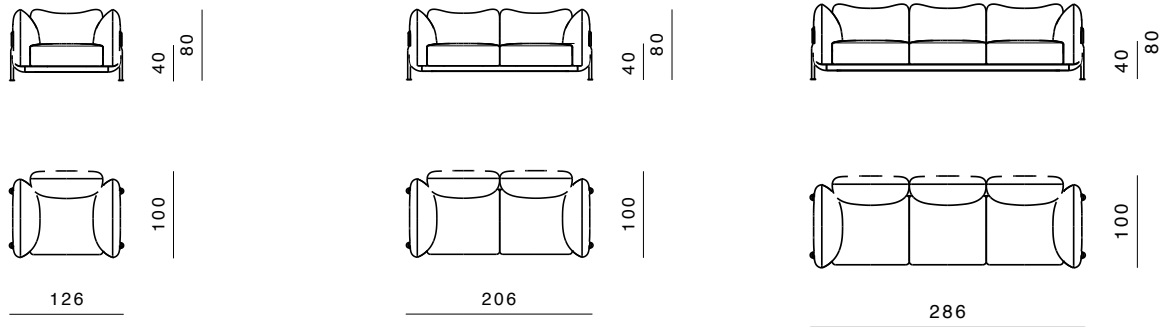

# Flo

Sofas, modular sofa and armchair\_Lorenza Bozzoli

## Structure

Internal structure in plywood panel and polyurethane rubber covered in fabric or leather.

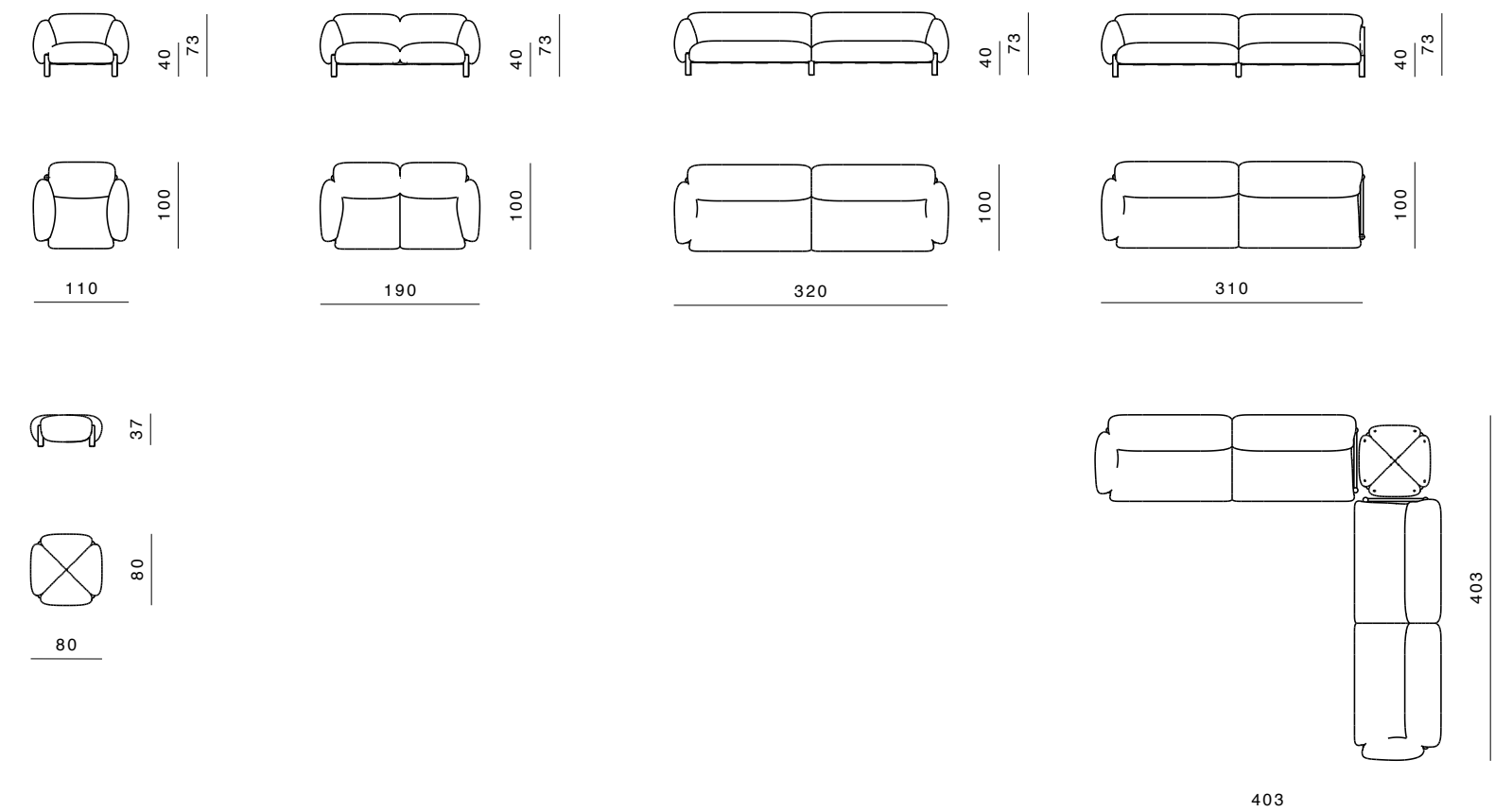

# Mambo

Modular sofa and armchair\_Lorenza Bozzoli

## Structure

Internal structure in plywood panel and polyurethane rubber covered in fabric or leather.

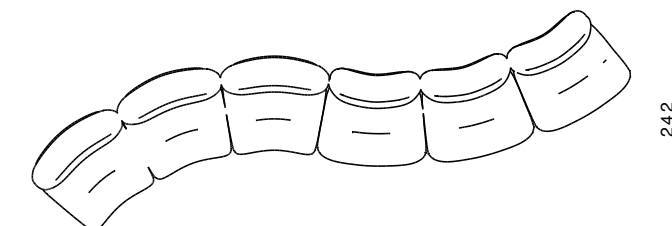
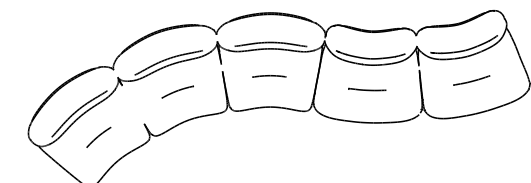
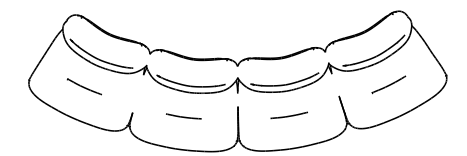
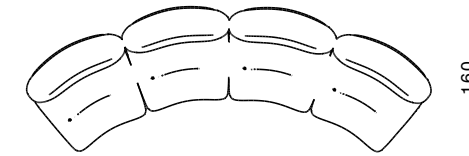
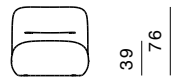

# Tria

Tables\_Lorenza Bozzoli

## Structure

Internal structure in plywood panel and polyurethane rubber covered in fabric or leather.

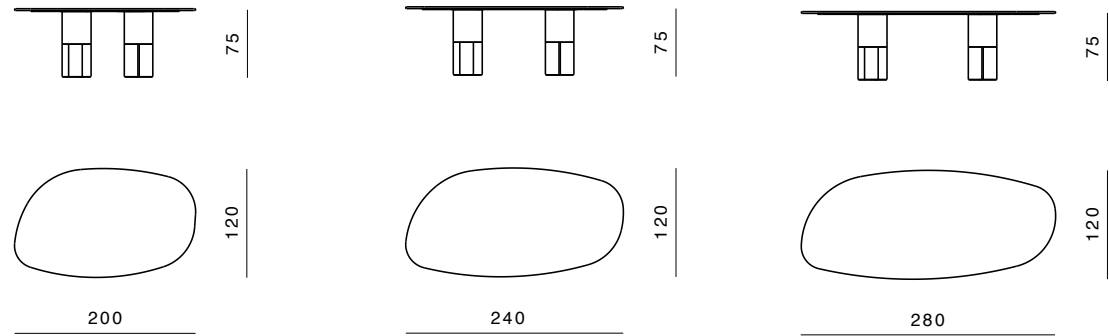

# Artù

Tables\_Paolo Rizzato

## Structure

Internal structure in plywood panel and polyurethane rubber covered in fabric or leather.

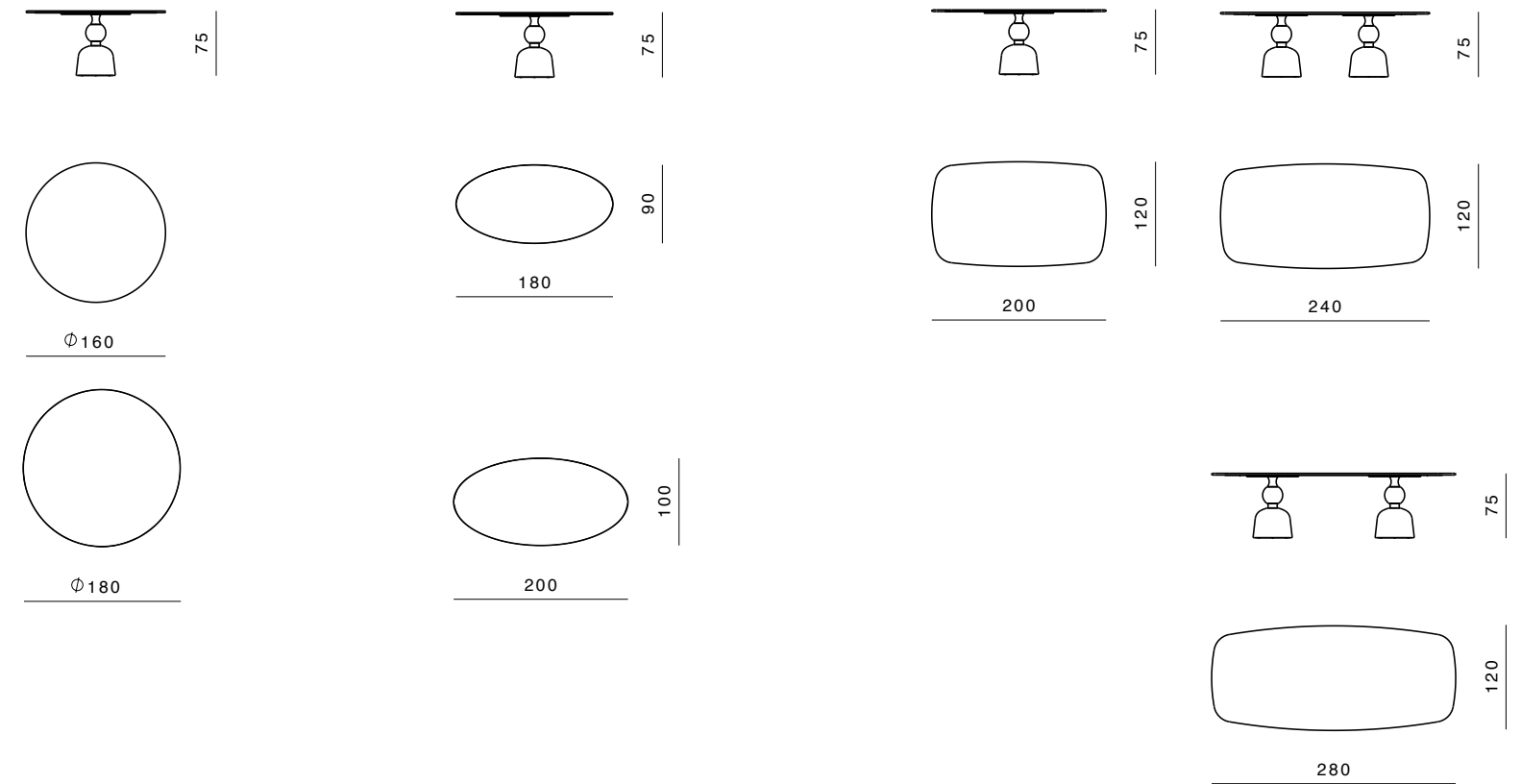

# Merlino

Tables\_Paolo Rizzatto

## Structure

Internal structure in plywood panel and polyurethane rubber covered in fabric or leather.

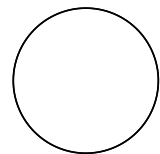

Φ 160

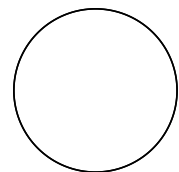

Φ 180

# Spritz

Small armchairs\_Lorenza Bozzoli

## Structure

Internal structure in plywood panel and polyurethane rubber covered in fabric or leather.

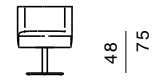

60



64

# Arch

Dining chair\_Richard Hutten

## Structure

Internal structure in plywood panel and polyurethane rubber covered in fabric or leather.



68

# Hillary

Dining chair\_Richard Hutten

## Structure

Internal structure in plywood panel and polyurethane rubber covered in fabric or leather.



52

# Shaker

Console\_Stefano Giovannoni

## Structure

Internal structure in plywood panel and polyurethane rubber covered in fabric or leather.

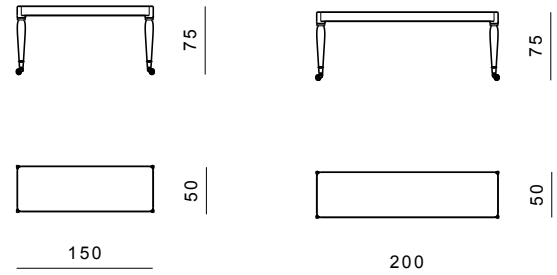

# Frame

Console\_Stefano Giovannoni

## Structure

Internal structure in plywood panel and polyurethane rubber covered in fabric or leather.

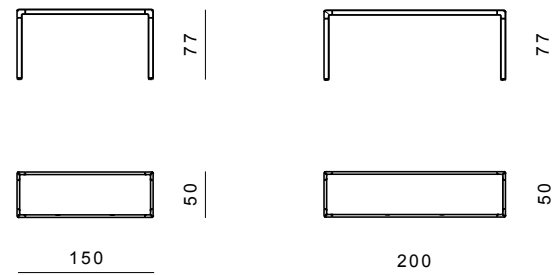

# Tria

Small tables\_Lorenza Bozzoli

## Structure

Internal structure in plywood panel and polyurethane rubber covered in fabric or leather.

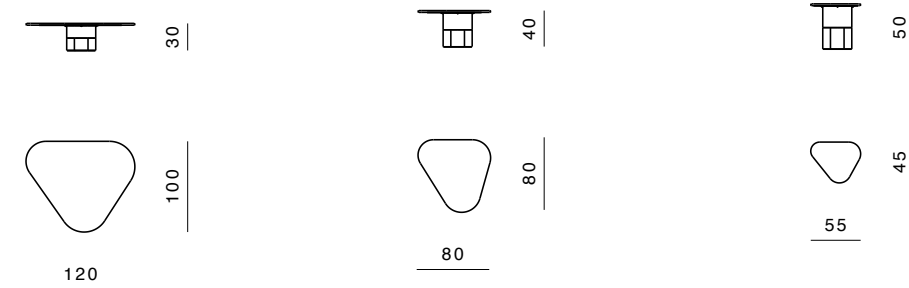

# Arnold

Small tables\_Paolo Rizzatto

## Structure

Internal structure in plywood panel and polyurethane rubber covered in fabric or leather.

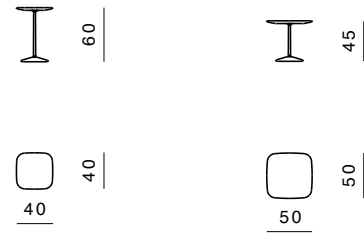

# Dapertutto

Small tables\_Paolo Rizzatto

## Structure

Internal structure in plywood panel and polyurethane rubber covered in fabric or leather.

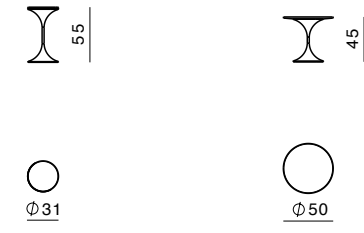

# Helios

Lamps\_Branch Creative

## Structure

Internal structure in plywood panel and polyurethane rubber covered in fabric or leather.

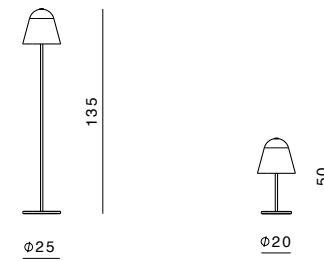

# Butterfly

Mirror\_Richard Hutten

## Structure

Internal structure in plywood panel and polyurethane rubber covered in fabric or leather.



**Photos**

Fabrizio Bergamo  
Cube Photoproduction

**Styling**

Candida Zanelli, Rosaria Galli

**Branding**

Christoph Radl, Antonella Provasi

**Graphic layout and Printing**

Intese Grafiche, Montichiari (Bs)

**Many Thanks to:**

Jab  
Nason Moretti

**GHIDINI 1961 INIDIHΘ**

is a trademark of  
Ghidini Giuseppe Bosco spa

via Gabriele D'Annunzio 27  
25069 Villa Carcina (BS) Italy  
T +39 030 8980521  
F +39 030 8981588  
info@ghidini1961.com

**Press office**

press@ghidini1961.com

**Sales office**

sales@ghidini1961.com

www.ghidini1961.com

