

FLEUR

2025

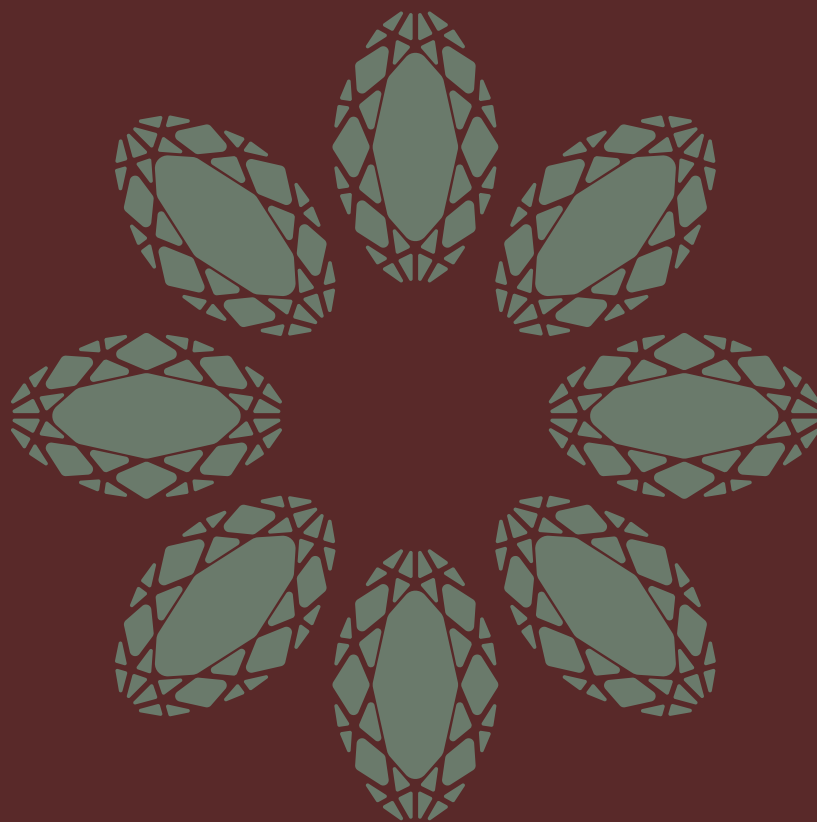

mmlampadari

FLEUR

Per la nuova edizione del nostro catalogo, abbiamo superato la tradizionale dicotomia tra Classico e Design e la nostra dedizione al prodotto ci ha spinto a ridefinire le collezioni trasformandole in visioni. Vogliamo offrire un'esperienza di prodotto che vada oltre l'attribuzione di un aggettivo coinvolgendo profondamente l'osservatore.

Il catalogo che avete tra le mani è il risultato di una meticolosa revisione del patrimonio creativo di MM Lampadari. Ogni pagina riflette l'habitat, la personalità e lo stile di vita che abbiamo immaginato per i nostri clienti.

La collezione Fleur rappresenta il culmine di questo processo: dettagli rigorosi, lucentezza damantina e riflessi preziosi. Questa collezione ospita i nostri prodotti più raffinati ed eleganti, fondendo la tradizione luminosa italiana con un'interpretazione moderna e senza tempo. Un taglio preciso e netto affina la materia grezza, trasformando ogni pezzo in un capolavoro luminoso, familiare e rassicurante nella sua rigidità formale.

For the new edition of our catalog, we have transcended the traditional dichotomy between Classical and Design. Our dedication to the product has driven us to redefine our collections, transforming them into visions. We aim to offer a product experience that goes beyond mere adjectives, deeply engaging the observer.

The catalog you hold in your hands is the result of a meticulous revision of MM Lampadari's creative heritage. Each page reflects the habitat, personality, and lifestyle we envision for our clients.

The Marquise collection represents the pinnacle of this process: rigorous details, diamond-like brilliance, and precious reflections. This collection showcases our most refined and elegant products, blending the luminous Italian tradition with a timeless modern interpretation. A precise and sharp cut refines the raw material, transforming each piece into a luminous masterpiece, familiar and reassuring in its formal rigor.

DA OLTRE 50 ANNI, PLASMIAMO LA MATERIA IN CAPOLAVORI DI LUCE

Da oltre cinquant'anni, MM Lampadari porta avanti l'eccellenza nell'illuminazione d'interni, combinando abilmente tradizione e innovazione. Specializzati nel lavoro del metallo e del vetro, creiamo lampade uniche che riflettono stile e passione. La nostra collezione esclusiva, frutto della collaborazione familiare con la vetreria, offre pezzi unici, dalla raffinata lavorazione del vetro di Murano alle soluzioni innovative in materiali tecnologici. Siamo impegnati a garantire valore attraverso prodotti e servizi di alta qualità, mantenendo viva l'arte dell'illuminazione.

Inoltre, MM Lampadari lavora anche nel settore contract, offrendo articoli custom e prodotti su disegno, adattabili alle esigenze specifiche dei nostri clienti. Con MM Lampadari, ogni ambiente si trasforma in uno scenario unico e suggestivo, dove la luce diventa un'arte che ispira e emoziona.

FOR OVER 50 YEARS, WE'VE SHAPED MATERIALS INTO MASTERPIECES OF LIGHT

For over fifty years, MM Lampadari has been a beacon of excellence in interior lighting, skillfully combining tradition and innovation. Specializing in metal and glasswork, we create unique lamps that reflect style and passion. Our exclusive collection, born from a family collaboration with the glassworks, offers unique pieces, from the refined craftsmanship of Murano glass to innovative solutions in high-tech materials. We are dedicated to providing value through high-quality products and services, keeping the art of lighting alive.

Additionally, MM Lampadari also operates in the contract sector, offering custom items and bespoke products tailored to the specific needs of our clients. With MM Lampadari, every environment is transformed into a unique and evocative setting, where light becomes an art that inspires and captivates.



INDEX



EOS 12

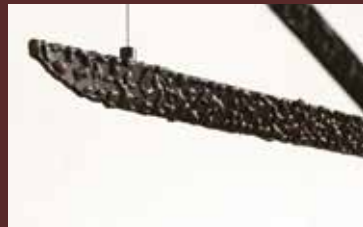

HANZO 18



MANSION 24



ARTÙ 30



TRAMA 34



GHIACCIOLO 38



ANFORA 42



BOTTE 48



BUBBLES 54



RUGIADA 60



BLOWN 68



BUTTERFLY 74



STELO 80



LEAVES 86



TOPAZIO 92



STALATTITE 98



PARIS 102



IRIS 110



EDERA16 118



ESSE 126



IRIS CL 132



NIK 136



ATENE 142



SPARTA 148



VILLA 156



OTTOCENTO 162



FIAMME 168



IMPERO 174



DECO 180

INDEX

ANFORA	42	IRIS	116
ARTÙ	30	IRIS CL	132
ATENE	142	LEAVES	86
BLOWN	68	MANSION	24
BOTTE	48	NIK	136
BUBBLES	54	OTTOCENTO	162
BUTTERFLY	74	PARIS	102
DECO	180	RUGIADA	60
EDERA16	118	SPARTA	148
EOS	12	STALATTITE	98
ESSE	126	STELO	80
FIAMME	168	TOPAZIO	92
GHIACCIOLO	38	TRAMA	34
HANZO	18	VILLA	156
IMPERO	174		

SPECIFICHE TECNICHE	188
TECHNICAL DETAILS	188

EOS

DESIGNED BY MM LAMPADARI WORKSHOP



EOS

Un flessuoso arco metallico, decorato a mano, termina la sua corsa sfociando nel diffusore in vetro soffiato, reso unico da un'esclusiva finitura "a regolite" che gli dona movimento e fascino. Perfetta per delle armoniche composizioni sospese, Eos si presta anche a un utilizzo singolo grazie all'eccellente rifrazione della sfera diffusore.

A supple metal arch, decorated by hand, flows into the blown glass diffuser, made unique by a unique "regolith" finish that provides it with movement and charm. Perfect for harmonious hanging compositions, Eos is also suitable for single use thanks to the excellent refraction of the diffusing sphere.





HANZO

DESIGNED BY MM LAMPADARI WORKSHOP



HANZO

Un profilo tagliente e quasi bidimensionale definisce nello spazio una direzione, una traiettoria grafica che genera luce.

I delicati riporti di materiale creano un rilievo organico, e rappresentano un affascinante parallelo tra la maestria dei forgiatori nipponici di spade e l'alto artigianato italiano.

A sharp, almost bidimensional profile defines a direction in space, a graphic trajectory that generates light.

The delicate additions of material create an organic embossed pattern, and represent a fascinating link between the mastery of Japanese swordsmiths and high Italian craftsmanship.

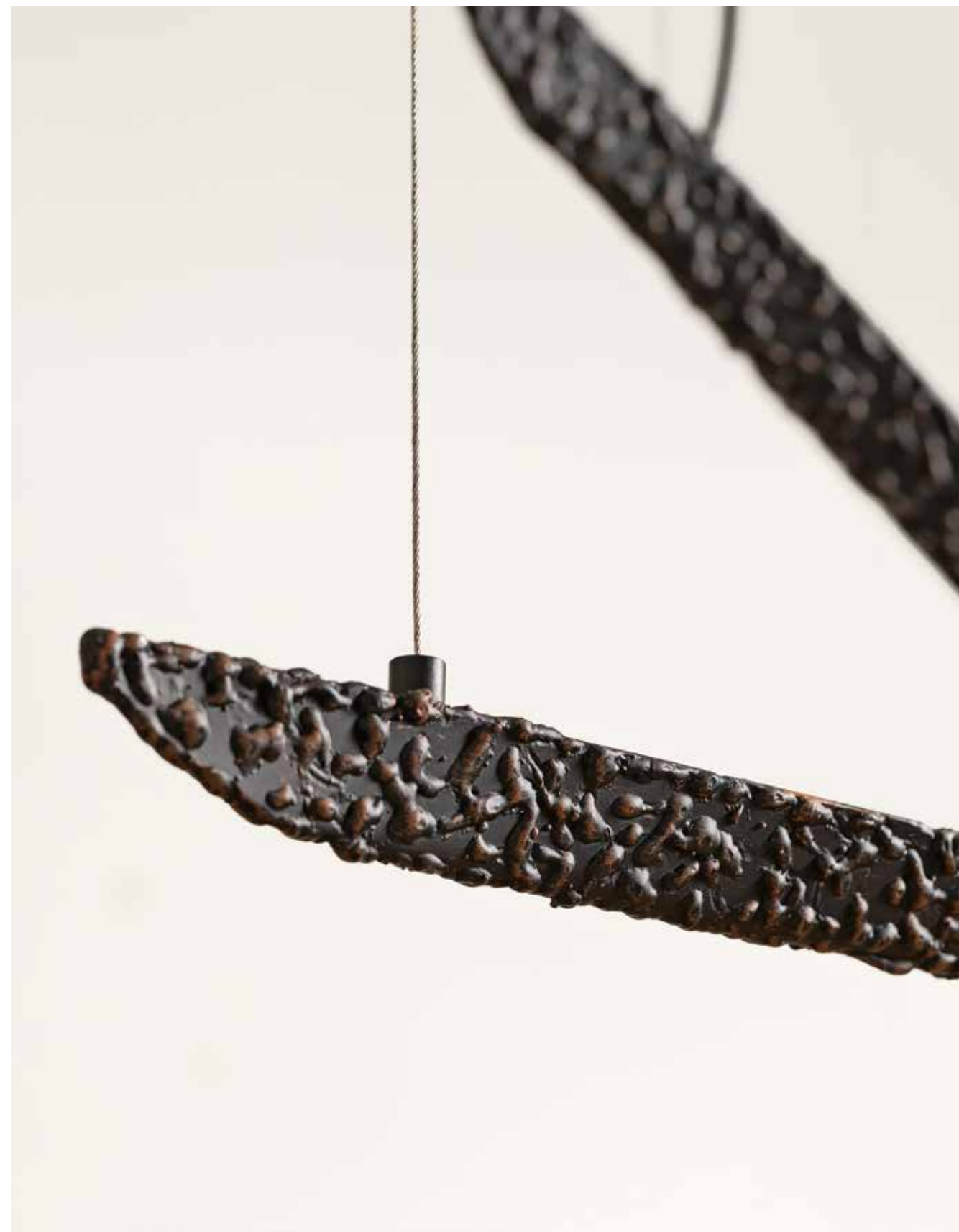

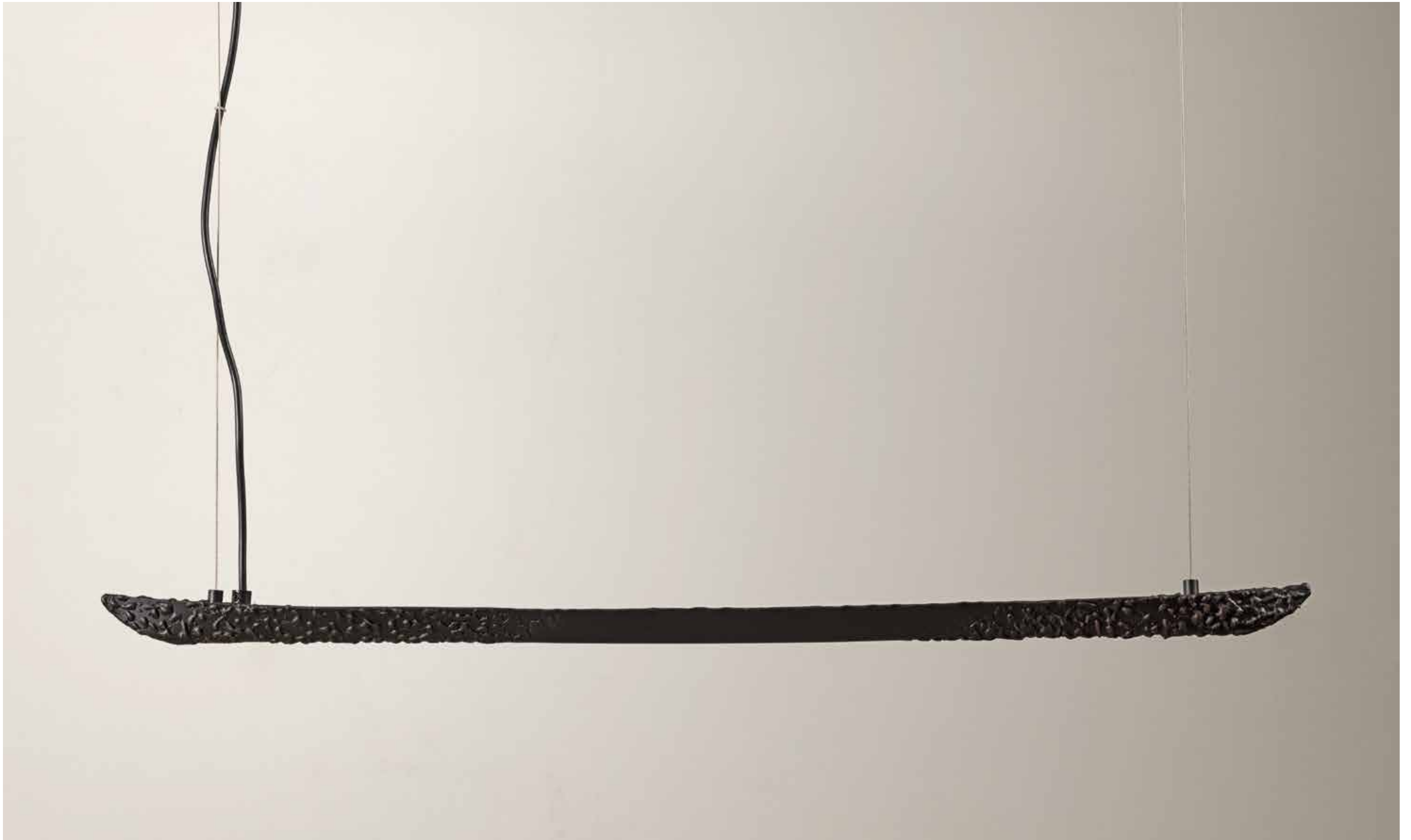

MANSION

DESIGNED BY MM LAMPADARI WORKSHOP



MANSION

Linee essenziali esaltano le materie prime scelte con cura ed un approccio di ricerca dell'armonia. Lampada a sospensione il cui cuore centrale è in velluto plissé verticale, progettata per inserirsi in perfetta equilibrio con il luogo ed al contempo esaltarne il tocco elegante.

Essential lines enhance the raw materials chosen with care and an approach to search for harmony. The pendant lamp's central heart is in vertical pleated velvet, designed to fit in perfect balance with the place and, at the same time, enhance the elegant touch.





ARTU

DESIGNED BY MM LAMPADARI WORKSHOP



ARTU

Semplicità e rigore applicati allo stile classico danno vita a questo inedito modello.

Come una corona medievale, sovrasta lo spazio con la sua figura imponente e a tratti austera, e al contempo lo abbraccia con la sua luce che si propaga in modo omogeneo dalla sua forma circolare.

Simplicity and rigor applied to the classic style give rise to this unusual model.

It is similar to an enormous dominating overhanging Medieval crown which at the same time embraces the entire room with its light which spreads in a uniform manner from its circular shape.



TRAMA

DESIGNED BY MM LAMPADARI WORKSHOP



TRAMA

Lampada a plafone in vetro a impronta diamantata: tutto lo splendore e tutta l'armonia di uno stile sempre più riconsiderato per eleganza e bellezza anche in ambienti moderni.

Ceiling lamp featuring a diamond-shapes pattern: all the brightness and the armony of a style more and more deemed elegant and beautiful, also in modern rooms.



GHIACCIOLO

DESIGNED BY MM LAMPADARI WORKSHOP

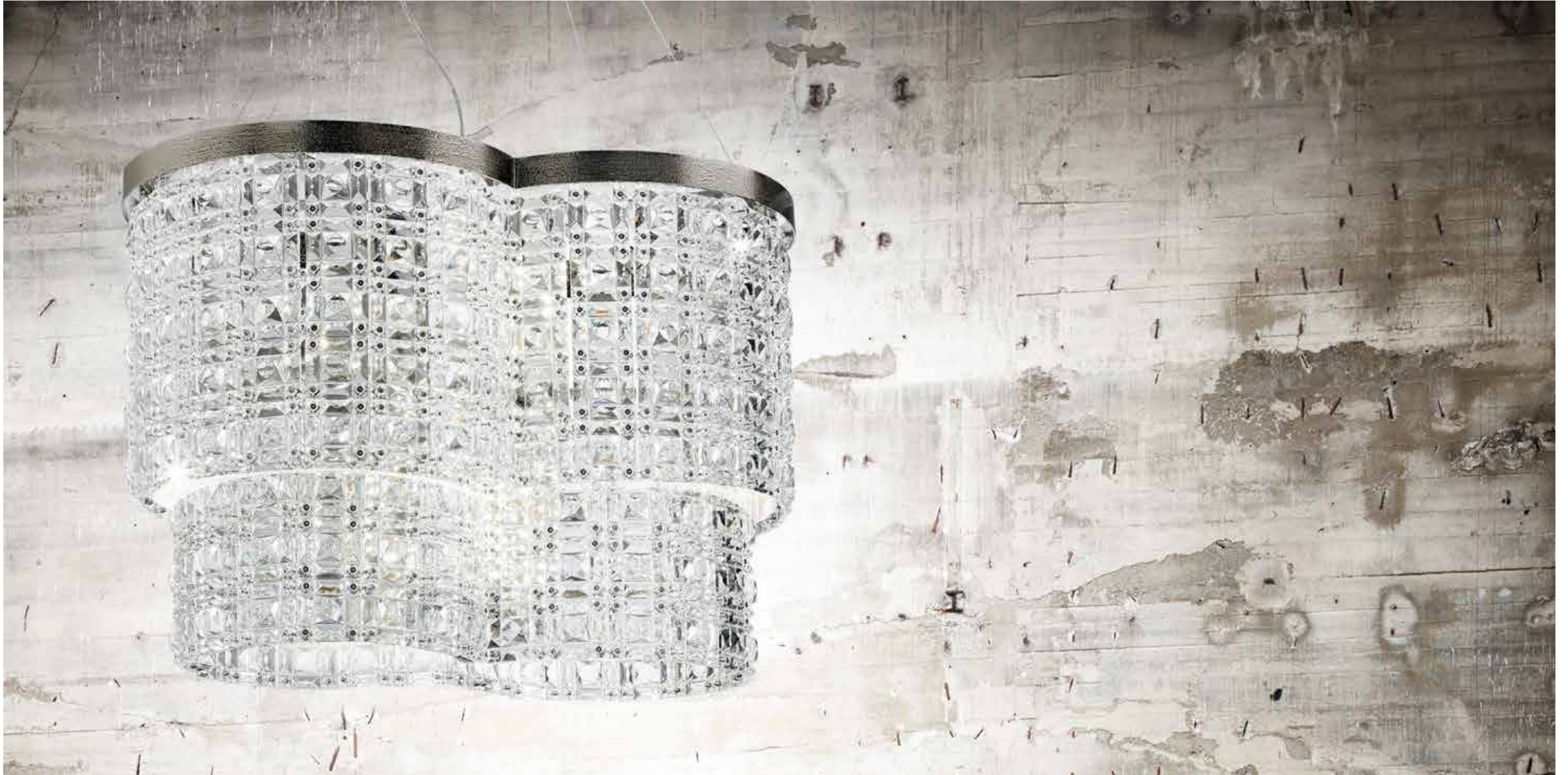

GHIACCIOLO

Composta da un elegante e raffinato tappeto di placche in vetro che unite tra loro formano una struttura simmetrica, ricca di sfaccettature e riverberi di luce per un'atmosfera senza tempo.

Consisting of an elegant and refined carpet of glass plaques, that together creates a symmetrical frame, rich of faceting and light glares for a timeless atmosphere.



ANFORA

DESIGNED BY MM LAMPADARI WORKSHOP



ANFORA

Continuità e raffinatezza. Le lampade della serie Anfora sono caratterizzate dalla semplicità del braccio dai fregi curvati a mano che si contrappone all'importanza del vetro soffiato a mano con trama balloton. Completano il quadro i cristalli trasparenti che danno un ulteriore tocco di luce.

Continuity and refinement. The lamps of the Anfora series are characterized by the simplicity of the arm with hand-curved friezes that contrasts with the importance of hand-blown glass with balloton texture. The picture is completed by transparent crystals that give an additional touch of light.





BOTTE

DESIGNED BY ENRICO DE GIRARDI



BOTTE

Struttura in metallo decorato con particolari forgiati a mano. Il vetro soffiato a mano con dettagli che riprendono il colore della struttura, rendono questa serie giovanile e molto innovativa.

Frame in metal decorated with hand-forged details. The hand-blown glass with details that reflect the color of the structure makes this collection young and very innovative.





BUBBLES

DESIGNED BY MM LAMPADARI WORKSHOP



BUBBLES

La finitura in foglia argento, i pendagli in cristallo ed il caratteristico design rendono la serie bubbles particolarmente unica ed attuale.

The finish in silver Leaf, the crystal drops and the particular design made range bubbles unique and actual.





RUGIADA



RUGIADA

DESIGNED BY MM LAMPADARI WORKSHOP

La serie realizzata in metallo con finitura in foglia argento e foglia oro e con diffusore in vetro di Murano soffiato. Piacevolmente arricchita da cristalli che danno luce e brillantezza.

This range is realized in metal enriched with a silver and gold leaf finish and with blown Murano glass. Pleasantly enriched with crystals that gives light and brightness.







BLOWN

DESIGNED BY MM LAMPADARI WORKSHOP



BLOWN

Ferro e vetro, materiali lontani fra loro, si fondono in Blown, lampade da terra e soffitto connubio di sensibilità diverse e competenze in ambiti differenti: forgiatura e vetreria sul fronte artistico e creativo. Blown è composta da una struttura metallica di acciaio in diverse finiture con il vetro soffiato all'interno. Illuminandosi completamente, garantisce una resa luminosa con un suggestivo gioco di ombre e riflessi.

Iron and glass, materials far from each other, merge in Blown, table and ceiling lamp, mix of different sensibilities and skills in different fields: forge and glass as artistic and creativ components. Blown is a forged frame in steel, available in different finishes, with blown glass inside. When completely lighted up, it gives a fascinating interplay of shadows and reflections.





BUTTERFLY

DESIGNED BY MM LAMPADARI WORKSHOP



BUTTERFLY

Il vetro decorato a mano viene imprigionato in questa serie da ali in ferro battuto, decorate in foglia oro. Disponibile nella versione da terra e da parete, questa serie viene completata da plafoniere a soffitto nelle forme ovale e tonda.

The hand decorated glass is imprisoned in this range from wrought iron wings, decorated in gold leaf. Available as floor and wall lamp, this family is completed with ceiling lamps with oval and round shapes.

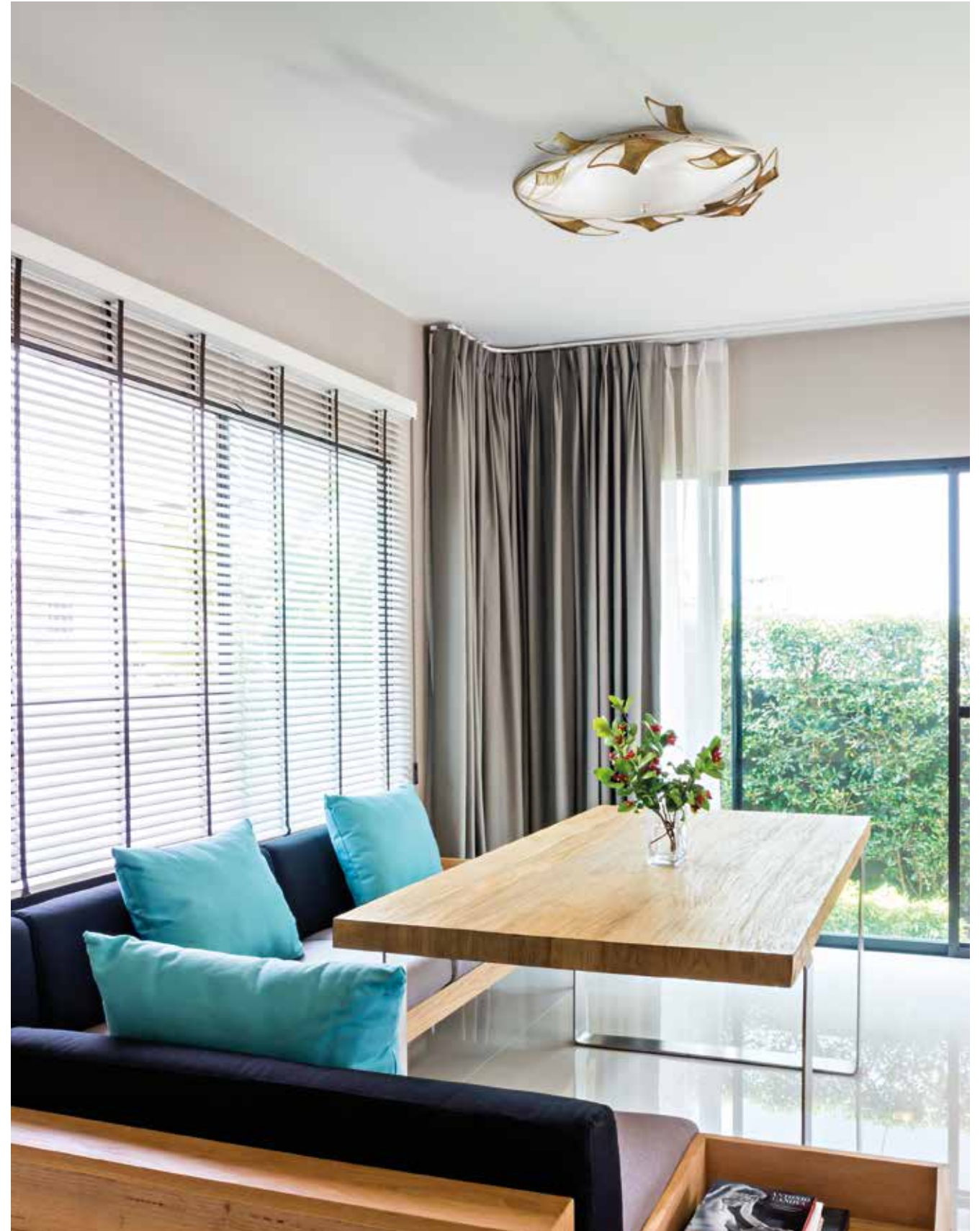



STELO

DESIGNED BY MM LAMPADARI WORKSHOP



STELO

Design Ufficio tecnico MM
Lampadari.

Serie di lampade realizzate
con braccia curvate che
creano un divertente effetto
irregolare. Impreziosita da
fiori stilizzati con inserti di
perle e completata con dei
semplici paralumi in stoffa
di forma conica.

*Range of lamps realized with
curved arms that create a
funny irregular effect. Made
precious with stylized flowers
with inserts of pearls, is
completed with simple fabric
shades with conic shape.*





LEAVES

DESIGNED BY MATTEO VALENTI

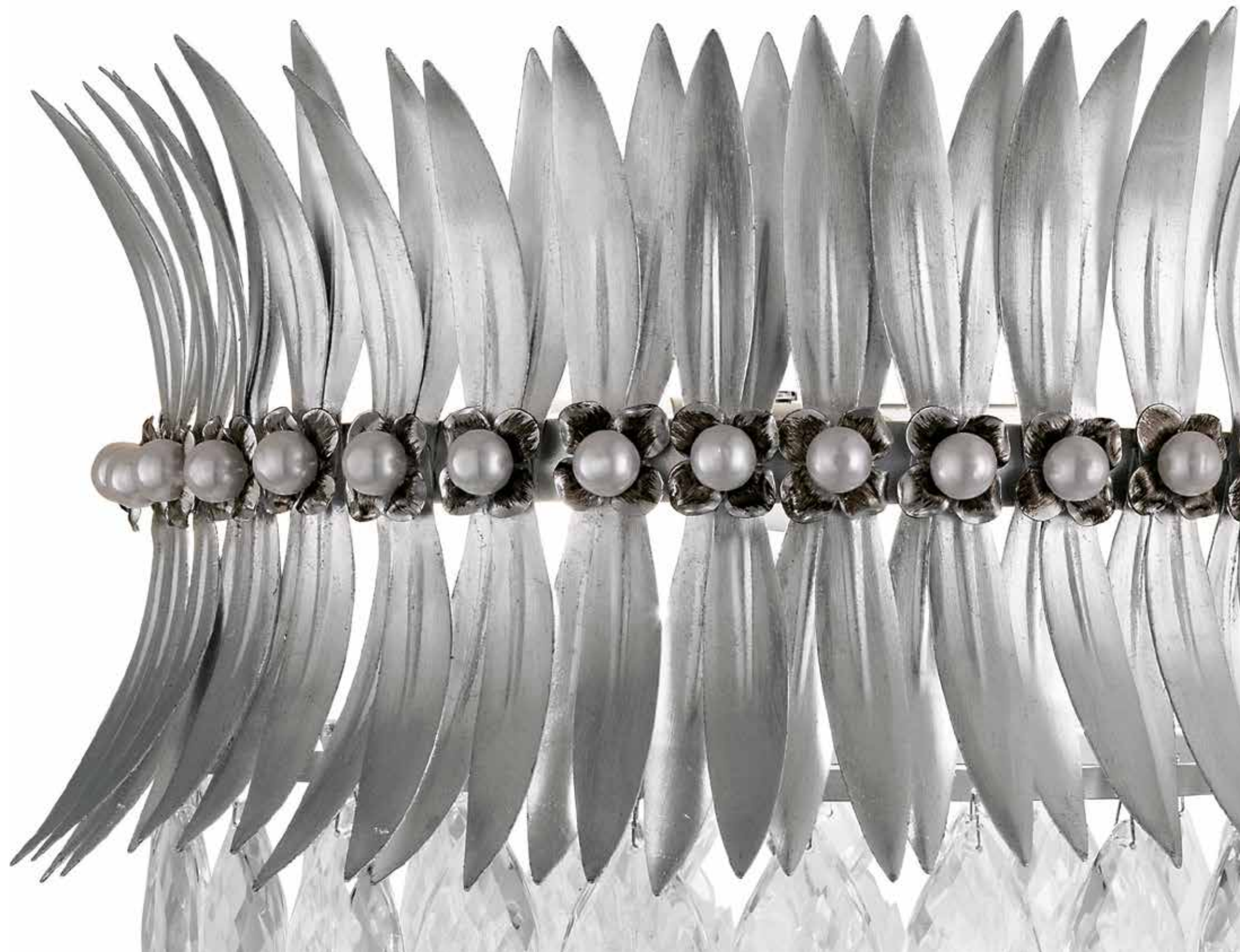

LEAVES

Serie di lampade con una cornice di foglie in metallo lavorato. La finitura in foglia argento, i pendagli in cristallo e il caratteristico design rendono la serie Leaves particolarmente unica e attuale.

Range of lighting fixtures with a frame made of hand-worked leaves. The silver foil finish, the crystal drops and the peculiar design make the Leaves range unique and contemporary.





TOPAZIO

DESIGNED BY MM LAMPADARI WORKSHOP



TOPAZIO

Dalla valorizzazione diretta ed esclusiva del materiale che risalta la purezza e la forma del vetro di Murano rinasce un classico dell'illuminazione veneziana: Topazio, composto da quadriedri in vetro trasparente e una montatura in finitura dorata.

Series Topazio, with precious "quadriedri" in transparent Murano glass and golden metal finish, reinvents a classical shape of Venetian lighting, enriching both the materials and the pure shape of the glass.





STALATTITE

DESIGNED BY ENRICO DE GIRARDI



STALATTITE

Serie di lampade e applique con vetri lavorati che richiamano l'effetto delle stalattiti. I vetri sono stati creati per donare alle lampade un effetto ghiaccio che si contrappone al calore della struttura in foglia oro e foglia argento.

Range of chandeliers and wall lamps with hand worked glasses that reminds the effect of the stalactites. The glasses are created to give to the lamps an ice effect that set up against the warmth of the frame in gold and silver leaf.



PARIS

DESIGNED BY MM LAMPADARI WORKSHOP



PARIS

Tradizione e raffinatezza. Le lampade della serie Anfora sono caratterizzate dalla semplicità del braccio e dai fregi curvati a mano che si contrappongono all'importanza del vetro soffiato a mano ed inciso. Completano il quadro i cristalli trasparenti che danno un ulteriore tocco di luce.

Tradition and elegance. The lamps of range Anfora are characterized by the simplicity of the arm and by the hand bended decoration, that set up against the importance of the blown glass decorated and cut by hand. Clear drops complete the range, giving a further touch of light.







IRIS

DESIGNED BY MM LAMPADARI WORKSHOP



IRIS

Collezione di lampade in metallo abilmente lavorato. Eleganti ed attuali finiture nei colori laccato bianco, nero o con finitura cromo. Dettagli di alta bigiotteria sapientemente creati per un'unica raffinata e ricercata personalizzazione. Paralumi neri con interno cromo.

Range of lamps in metal wisely worked. Finishes elegant and actual in laked colour, white, black and chrome. Details of high jewelery wisely created for a unique and refined personalization. Black shades with chrome inside.







EDERA16

DESIGNED BY CENTRO STILE MM LAMPADARI - RESTYLED BY LEO DE CARLO



EDERA16

Il classico, per definizione, non tramonta mai. L'alta decorazione degli chandelier resta una lavorazione che colpisce e fa innamorare al primo sguardo. In questa realizzazione il ferro è stato finemente lavorato come da tradizione, ma la scelta dei colori conferisce a quest'opera dal sapore d'altri tempi un tocco di modernità affascinante e sorprendente.

By its very definition anything "classic" stands the test of time. The decorations on the chandeliers have a great impact and make people fall in love with them from the very first glance. In this item the iron has been knowingly crafted as per tradition but the choice of the colors confers to this work with a taste of the past a surprising and fascinating touch of modernity.







ESSE

DESIGNED BY ENRICO DE GIRARDI



ESSE

Questa serie è caratterizzata da una struttura ad esse che la rende leggera ma decorativa allo stesso tempo. In particolare la lampada a muro nella versione piccola e grande, diventa un elemento d'arredamento e non solo di illuminazione.

This series is characterized by an s-shaped structure which makes it light but decorative at the same time. In particular, the wall lamp in the small and large version becomes a furnishing element and not just a lighting element.





IRIS CL

DESIGNED BY ENRICO DE GIRARDI



IRIS CL

Collezione di lampade in metallo abilmente lavorato. La tradizione dei colori sposa la contemporaneità delle forme. Completano questa serie il tavolo e le sedie per un risultato d'effetto.

Range lamps cleverly worked in metal. The tradition of the color match he contemporaneity of the forms. Table and the chairs complete this range for a result of effect.



NIK

DESIGNED BY MM LAMPADARI WORKSHOP



NIK

Serie di lampade di stile classico tradizionale. La struttura è in metallo con finiture nei colori avorio sfumato oro e brunito sfumato oro. La luce viene diffusa da eleganti paralumi per creare una calda atmosfera.

Range of lamps in classical traditional style. The frame in metal painted in ivory/gold finish and bronze/gold finish. The light comes through elegant shades that create a warm atmosphere.





ATENE

DESIGNED BY MM LAMPADARI WORKSHOP



ATENE

Realizzata con struttura in metallo impreziosita da vetro in piastra bianco latte che conferisce bellezza ed unicità ad ogni singolo pezzo

Realized with metal frame made precious with white glass plate, that gives beauty and singleness to each piece.





SPARTA

DESIGNED BY MM LAMPADARI WORKSHOP



SPARTA

Realizzata in metallo con particolari in fusione e vetri in piastra con graniglia cristallo oro. Disponibile anche con paralumi plissettati.

*Realized in metal with casting details and plate glasses in clear gold grit.
Available also with plissè shades.*







VILLA

DESIGNED BY ENRICO DE GIRARDI



VILLA

Realizzata in metallo con tubi quadri piegati a mano e pendenti a forma di goccia trasparenti; abilmente rifinita nei colori foglia oro e foglia argento.

Realized in metal with square tubes bended by hand and transparent drops shaped details; wisely painted in gold and silver leaf.





OTTOCENTO

DESIGNED BY ENRICO DE GIRARDI



OTTOCENTO

Adatta ad ambienti importanti, e scelta da chi cerca un risultato d'effetto, la serie Ottocento rispecchia la tradizione della lavorazione a mano del metallo nella struttura e la tradizione del cristallo trasparente nei pendenti.

Suitable for important rooms, and chosen by those who wants a scenic effect, range Ottocento reflects the tradition of the metal hand work in the frame, and the tradition of the clear crystals in the drops.





FIAMME

DESIGNED BY ENRICO DE GIRARDI

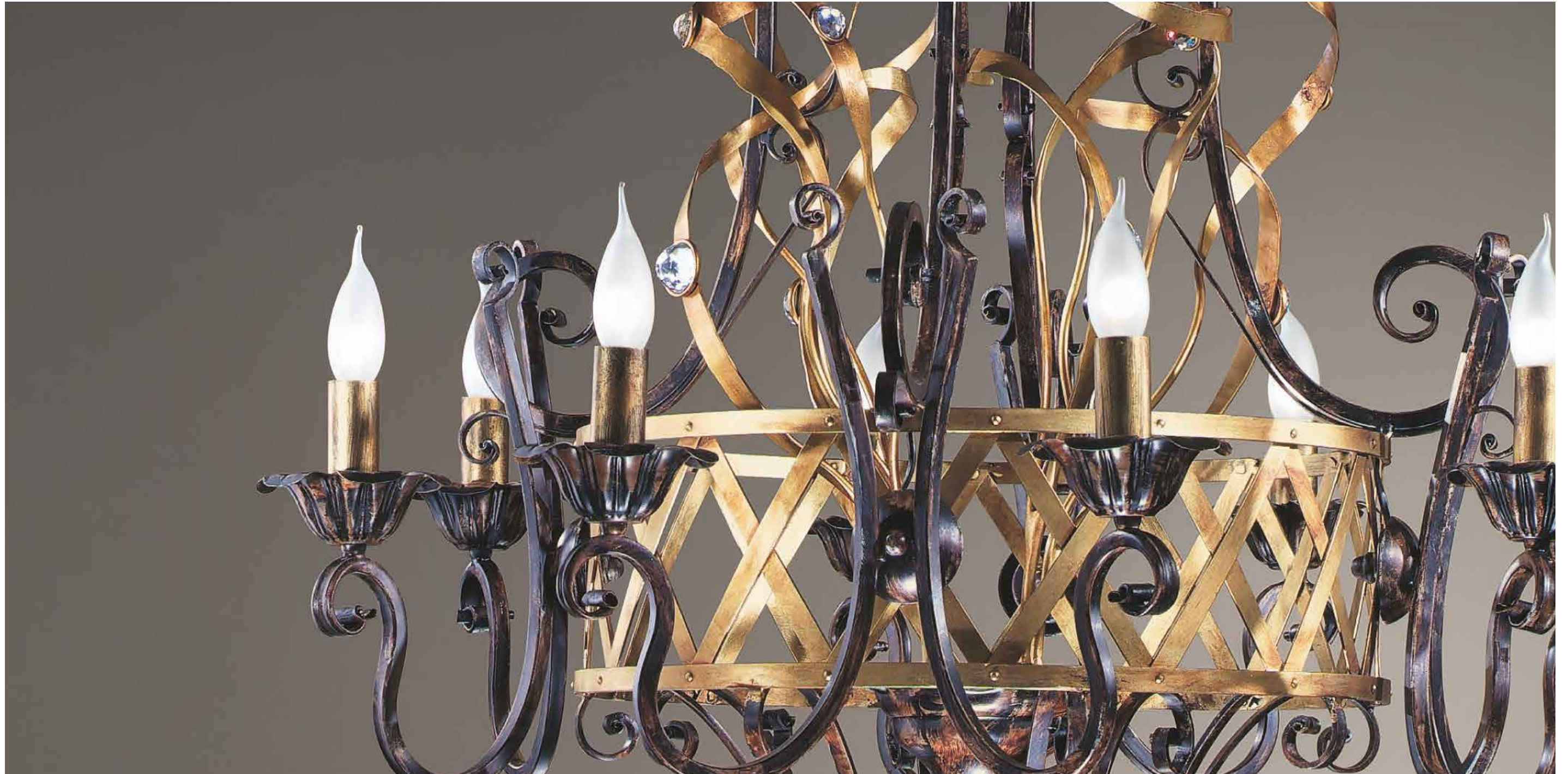

FIAMME

Il fuoco con cui viene lavorato il metallo sembra prendere forma in questa serie, acceso dal colore oro che contrasta col nero della struttura. Particolarmente vivo lo troviamo nella versione a 24 luci, con misure fuori standard e adatte per ambienti di grandi dimensioni.

The fire with which is worked the metal, seems to take shape in this family, lighted up by the gold color that contrasts with the black of the frame. Particularly bright, we can find it in the 24 lights-version, with non-standard size, suitable for rooms of large dimensions.





IMPERO

DESIGNED BY ENRICO DE GIRARDI



IMPERO

Nella serie Impero si sposano la sinuosità delle linee dei bracci con la regolarità del vetro soffiato. Particolarmente adatta per ambienti classici, grazie ai vetri nelle varianti color alabastro e vetro ottico trasparente più oro: rende l'atmosfera calda ed accogliente.

In this family Impero the sinuous lines of the arms match the regularity of the blown glass. Particularly suitable for classic rooms, thanks to glasses in the variant colour alabaster and optical transparent with gold accent: makes the atmosphere warm and comfortable.





DECO

DESIGNED BY ENRICO DE GIRARDI



DECO

Struttura in metallo con ricci piegati a mano e foglie forgiate. Impreziosito da vetri di Murano disponibili in vari colori, questa serie vanta lampade a soffitto ed a parete in varie forme e dimensioni. Particolarmente adatta per ambienti classici.

Metal frame with hand bended curls and hand forged leaves. Made precious by Murano glasses available in different colors, this range includes ceiling and wall lamps in different shapes and dimensions. Particularly suitable for classic rooms.







SEZIONE TECNICA
TECHNICAL SECTION

ANFORA

Lampada in metallo verniciato, e vetro murano balloton
Metal lamp painted treatment, and murano balloton glass

Struttura / Frame

V2968
brunito dettagli polvere oro
burnished gold dust details

Diffusore / Diffuser

vetro murano cristallo
balloton
murano glass balloton
crystal

Illuminazione / light source

LED 10W E14



Dimmerabile con convertitore DALI su richiesta
Dimmable with DALI converter on request



Utilizzo da interno
Indoor use



Prodotto dimmerabile
Dimmable

Lampadina non compresa / Bulb not included.



Art. 6468/5

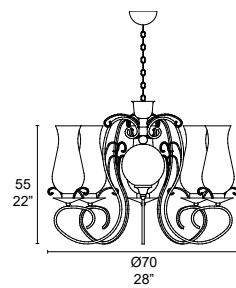

Art. 6468/3

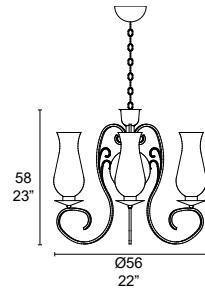

Art. 6468/A1

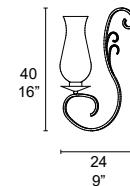

Art. 6468/L1

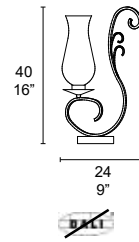

Fleur

ARTU'

Lampada in metallo verniciato e vetro lastra decorato
Lamp in painted metal and decorated glass plate

Struttura / Frame

V2962
ottone brunito galvanico
galvanic burnished brass

Diffusore / Diffuser

Vetro lastra decorato
alabastro
Glass plate decorated
alabaster

Illuminazione / light source

LED 20W E27



Dimmerabile con convertitore DALI su richiesta
Dimmable with DALI converter on request



Utilizzo da interno
Indoor use



Prodotto dimmerabile
Dimmable

Lampadina non compresa / Bulb not included.

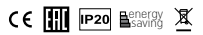

Art. 7262/5

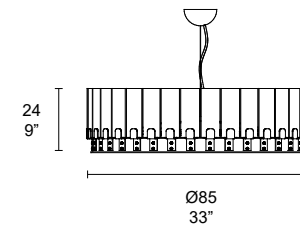

Art. 7262/4

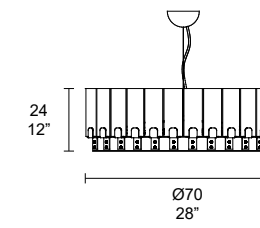

ATENE

Lampada in metallo verniciato e vetro lastra decorato
Lamp in painted metal and decorated glass plate

Struttura / Frame

V2733
Brunito invecchiato
Antiqued burnished

Diffusore / Diffuser

○ vetro piastra effetto cretto
glass plate cracked effect

Illuminazione / light source

LED 20W E27 LED 10W E14



Dimmerabile con convertitore DALI su richiesta
Dimmable with DALI converter on request



Utilizzo da interno
Indoor use



Prodotto dimmerabile
Dimmable

Lampadina non compresa / Bulb not included.



Art. 7092/1

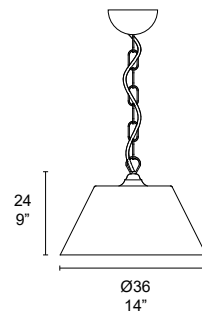

Art. 7092/P2

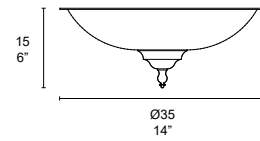

Art. 7092/P4

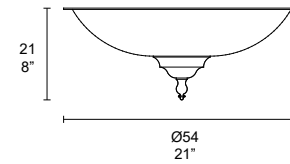

Fleur

BLOWN

Lampada in metallo naturale o galvanico e vetro murano soffiato in gabbia
Lamp in natural or galvanic metal and blown murano glass in cage

Struttura / Frame

V0197
Galvanica oro zecchino
Gold plated galvanic

V2652
Nickel lucido
Glossy nickel

Diffusore / Diffuser

○ vetro murano cristallo
soffiato in gabbia_
crystal murano glass
cage blown

Illuminazione / light source

LED 20W E27



Dimmerabile con convertitore DALI su richiesta
Dimmable with DALI converter on request



Utilizzo da interno
Indoor use



Prodotto dimmerabile
Dimmable

Lampadina non compresa / Bulb not included.



Art. 6945/1 01

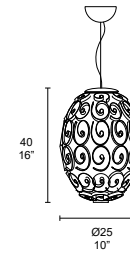

Art. 6945/1

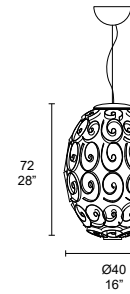

Art. 6945/LT1

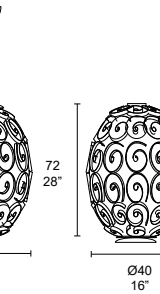

Art. 6945/L1

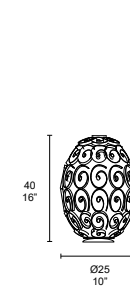

Art. 6993/1

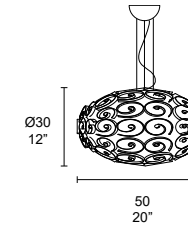

BOTTE

Lampada in metallo decorato e vetro murano
Hand painted metal lamp and murano glass

Struttura / Frame

V1784
Marrone opaco puntinato oro
con dettagli polvere argento
Matt brown, gold dotted with
silver powder details

Diffusore / Diffuser

Vetro soffiato cristallo
regolite
Blown glass crystal
regolith effect

Illuminazione / light source

5W G9 20W E27



Dimmerabile con convertitore DALI su richiesta
Dimmable with DALI converter on request



Utilizzo da interno
Indoor use



Prodotto dimmerabile
Dimmable

Lampadina non compresa / Bulb not included.



Art. 6088/5

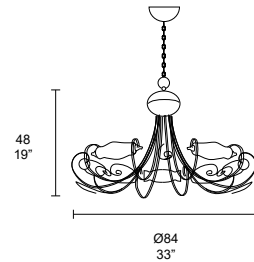

Art. 6087/P2

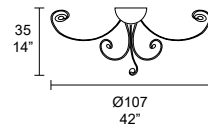

Art. 6087/A1

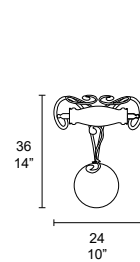

Art. 6088/A1

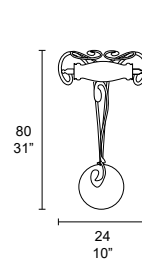

Art. 6087/LT3

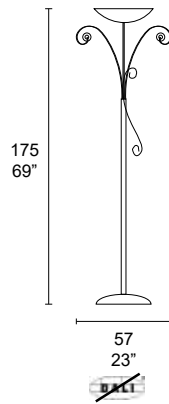

Art. 6087/L1

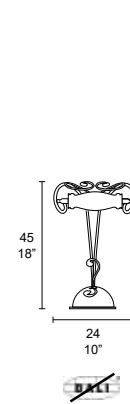

Fleur

BUBBLES

Lampada in metallo galvanico, vetro e paralumi
Lamp in galvanic metal, glass and lampshades

Struttura / Frame

V2719
Argento galvanico
Galvanic silver

Diffusore / Diffuser

paralume plissettato
moirè avorio con borda-
tura argento
moirè ivory pleated Im-
pashade with silver hem

Illuminazione / light source

10W E14 20W E27



Dimmerabile con convertitore DALI su richiesta
Dimmable with DALI converter on request



Utilizzo da interno
Indoor use



Prodotto dimmerabile
Dimmable

Lampadina non compresa / Bulb not included.



Art. 7062/1

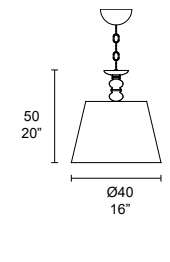

Art. 7062/5

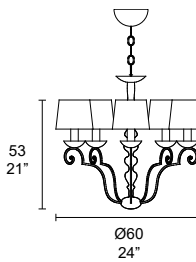

Art. 7062/8

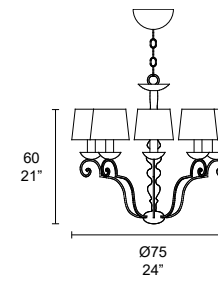

Art. 7062/A2

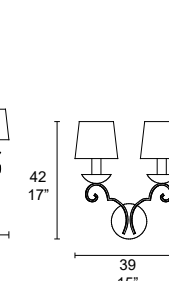

Art. 7062/L100

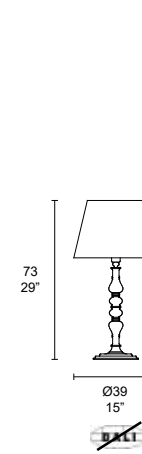

Art. 7062/L101



Art. 7062/LT1

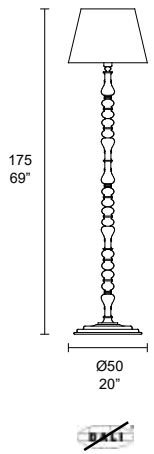

BUTTERFLY

Lampada in metallo decorato e vetro murano
Decorated metal lamp and Murano glass

Struttura / Frame

V1703
bianco antico, dettagli
foglia oro antico
antique white, antique
gold leaf details

Diffusore / Diffuser

vetro soffiato scavo
"scavo" blown glass

Illuminazione / light source

LED 10W E14 LED 20W E27

 Dimmerabile con convertitore DALI su richiesta
Dimmable with DALI converter on request

 Utilizzo da interno
Indoor use

 Prodotto dimmerabile
Dimmable

Lampadina non compresa / Bulb not included.

Art. 5627/A1

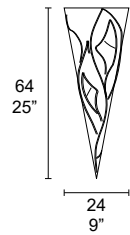

Art. 5627/LT1

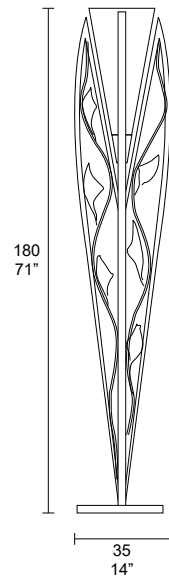

Art. 5627/P4

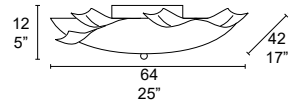

Art. 5627/P5

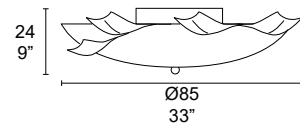

Fleur

DECO

Lampada in metallo decorato e vetro colato
Decorated metal lamp and poured glass

Struttura / Frame

V2314
oro antico, dettagli foglia oro
antique gold, gold leaf details

Diffusore / Diffuser

vetro martellato cristallo
hammered glass crystal

vetro martellato ambra
hammered glass amber

vetro martellato verde
hammered glass green

Illuminazione / light source

LED 10W E14 LED 20W E27

 Dimmerabile con convertitore DALI su richiesta
Dimmable with DALI converter on request

 Utilizzo da interno
Indoor use

 Prodotto dimmerabile
Dimmable

Lampadina non compresa / Bulb not included.

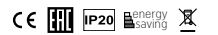

Art. 6740/4

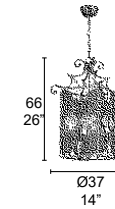

Art. 6740/9

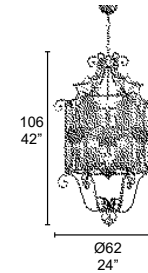

Art. 6740/A2

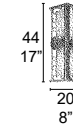

Art. 6740/LT4

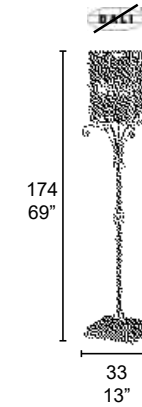

Art. 6740/P6

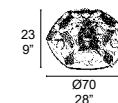

Art. 6741/4

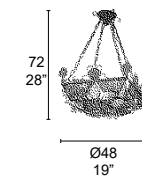

Art. 6741/12

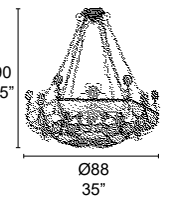

Art. 6741/A2

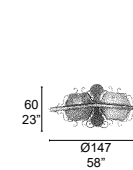

Art. 6741/P4

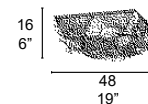

Art. 6763/A3

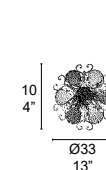

Art. 6764/6

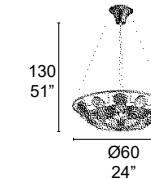

Art. 6765/P6

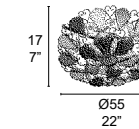

Art. 6765/A1

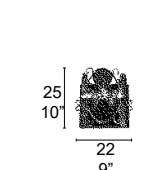

EDERA_16

Lampada in metallo verniciato e decorato, dettagli in vetro e diffusori in borosilicato
Painted and decorated metal lamp, glass details and borosilicate diffusers

Struttura / Frame

V2363
Struttura nera con foglie ocre e verdi decorate con pennellate dorate
Black frame with ocher and green leaves decorated with golden brushstrokes

Diffusore / Diffuser

Vetro borosilicato sablé-
Borosilicate glass satin

Illuminazione / light source

LED 10W E14 5W G9

 Dimmerabile con convertitore DALI su richiesta
Dimmable with DALI converter on request

 Utilizzo da interno
Indoor use

 Prodotto dimmerabile
Dimmable

Lampadina non compresa / Bulb not included.



Art. 6754/12

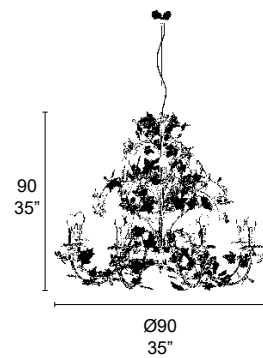

Art. 6754/8



Art. 6754/5

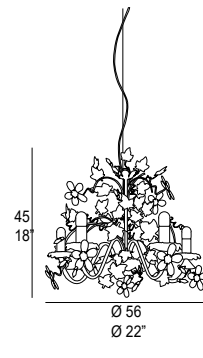

Art. 6754/P3

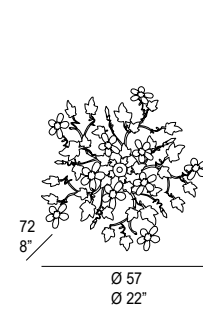

Art. 6754/A1

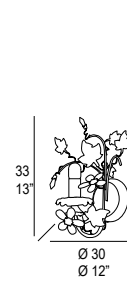

EOS

Lampada in metallo decorato e vetro murano
Decorated metal lamp and murano glass

Struttura / Frame

V2913
nero opaco ombreggiato
marrone
brown shaded matt black

Diffusore / Diffuser

Vetro soffiato effetto
regolite
Blown glass with regolith
effect

Illuminazione / light source

LED 10W E14

 Dimmerabile con convertitore DALI su richiesta
Dimmable with DALI converter on request

 Utilizzo da interno
Indoor use

 Prodotto dimmerabile
Dimmable

Lampadina non compresa / Bulb not included.

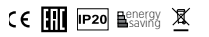

Art. 7428/1 S

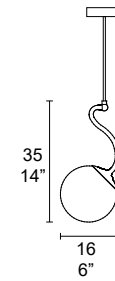

Art. 7428/1 M

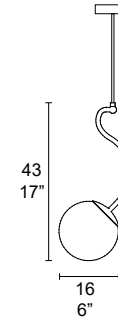

Art. 7428/1 L

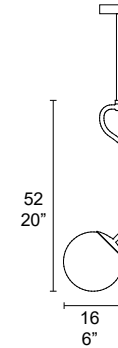

ESSE

Lampada in metallo decorato e vetro murano
Decorated metal lamp and murano glass

Struttura / Frame

V1723
nero opaco sfumato mar-
rone con dettagli foglia
oro anticata
brown shaded matt black
with antiqued gold leaf
details

Diffusore / Diffuser

Vetro soffiato dorato
satinato
satin golden blown
glass

Illuminazione / light source

LED 10W E27

 Dimmerabile con convertitore DALI su richiesta
Dimmable with DALI converter on request

 Utilizzo da interno
Indoor use

 Prodotto dimmerabile
Dimmable

Lampadina non compresa / Bulb not included.



Art. 5931/8

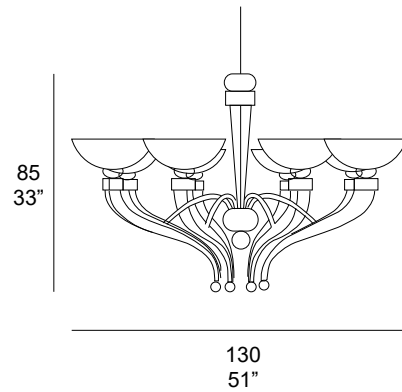

Art. 5931/A1

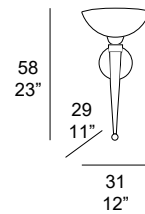

Fleur

FIAMME

Lampada in metallo decorato
Decorated metal lamp

Struttura / Frame

V2176
nero opaco velato bitume,
dettagli foglia oro
matt black sheer bitumen,
gold leaf details

Diffusore / Diffuser

Illuminazione / light source

LED 10W E14

 Dimmerabile con convertitore DALI su richiesta
Dimmable with DALI converter on request

 Utilizzo da interno
Indoor use

 Prodotto dimmerabile
Dimmable

Lampadina non compresa / Bulb not included.

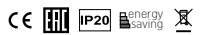

Art. 6618/16+8

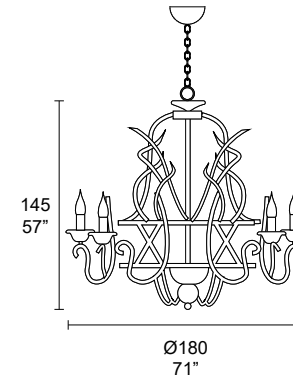

Art. 6618/8

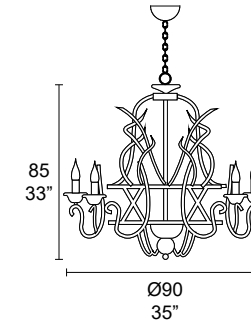

Art. 6618/A2

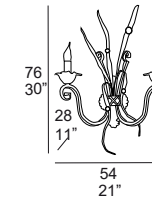

Fleur

GHIACCIOLO

Lampada in metallo galvanico e vetro gemma molato
Galvanic metal lamp and smoothed gem glasses

Struttura / Frame

V2652
nichel spazzoalto
brushed nickel

Diffusore / Diffuser

cristallo gemma
molato
smoothed chrystal
gems

Illuminazione / light source

5W G9



Dimmerabile con convertitore DALI su richiesta
Dimmable with DALI converter on request



Utilizzo da interno
Indoor use



Prodotto dimmerabile
Dimmable

Lampadina non compresa / Bulb not included.



Art. 7070/6

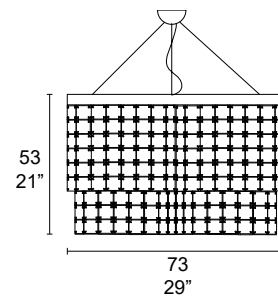

Art. 7070/A2

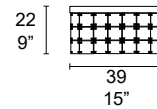

Fleur

HANZŌ

Lampada in metallo verniciato e decorato
Painted and decorated metal lamp

Struttura / Frame

V2913
nero opaco ombreggiato
marrone
brown shaded matt black

Diffusore / Diffuser

PMMA opale
Opal PMMA

Illuminazione / light source

STRIP LED 24V 3000K
(Sx5W) - (Mx7W) - (Lx12W) - (XLx23W)



Dimmerabile con convertitore DALI su richiesta
Dimmable with DALI converter on request



Utilizzo da interno
Indoor use



Prodotto dimmerabile
Dimmable



Tensione d'uso
Voltage



Modulo LED integrato sostituibile
Integrated replaceable LED module

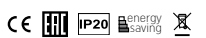

Art. 7422/1 S

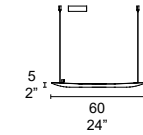

Art. 7422/1 M

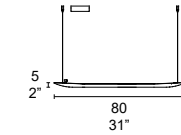

Art. 7422/1 L

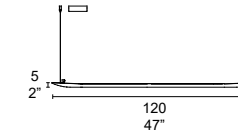

Art. 7422/1 XL

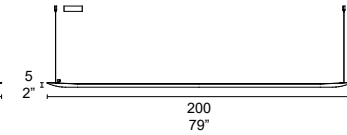

Art. 7422/1 S floor



Art. 7422/1 M floor



Art. 7422/1 L floor

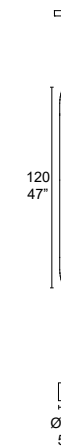

Art. 7422/1 XL floor

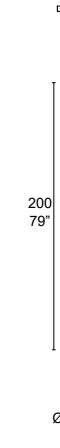

IMPERO

Lampada in metallo decorato e vetro murano
Painted metal lamp and murano glass

Struttura / Frame

V1681
decorazione rame ossidato,
dettagli foglia oro anticata
oxidized copper decoration,
antiqued gold leaf details

Diffusore / Diffuser

Vetro soffiato satinato
Satin blown glass

vetro cristallo bullè
murano glass bullè

Vetro soffiato effetto
regolite
Blown glass with regolith
effect

Illuminazione / light source

LED 20W E27 LED 10W E14

DALI Dimmerabile con convertitore DALI su richiesta
Dimmable with DALI converter on request

Utilizzo da interno
Indoor use

Prodotto dimmerabile
Dimmable

Lampadina non compresa / Bulb not included.



Fleur

IRIS

Lampada in metallo galvanico e paralume
Galvanic metal lamp and lampshade

Struttura / Frame

V2650
nero lucido
glossy black

V1607
cromo lucido
glossy chrome

V2553
bianco lucido
glossy white

Diffusore / Diffuser

Paralume linet nero-
cromo
Black-chrome linet
lampshade

Illuminazione / light source

LED 10W E14

DALI Dimmerabile con convertitore DALI su richiesta
Dimmable with DALI converter on request

Utilizzo da interno
Indoor use

Prodotto dimmerabile
Dimmable

Lampadina non compresa / Bulb not included.

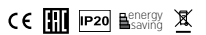

Art. 6064/1

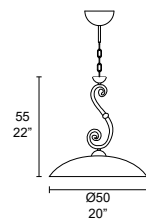

Art. 6175/6

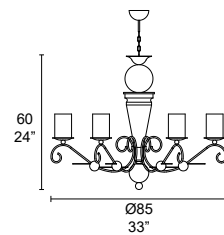

Art. 5972/8

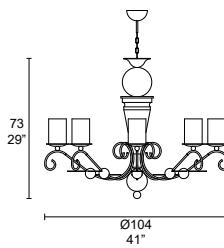

Art. 5972/12

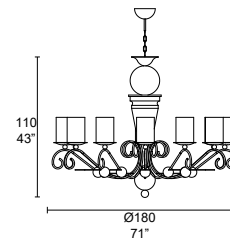

Art. 5972/12+6

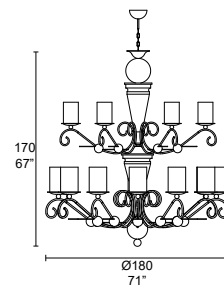

Art. 7059/6

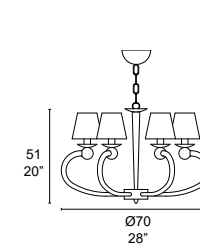

Art. 7059/A2 01

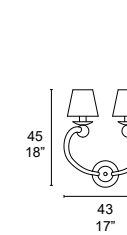

Art. 7059/A1

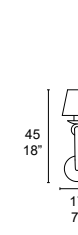

Art. 5972/LT1

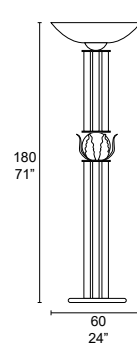

Art. 6175/A1

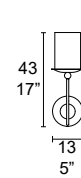

Art. 5972/A2

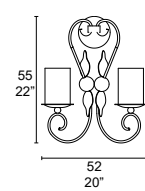

IRIS_CL

Lampada in metallo decorato e vetro murano
Decorated metal lamp and murano glass

Struttura / Frame

V1691
Nero sfumato oro con dettagli
foglia oro anticata
Gold shaded black with antiqued
gold leaf details

Diffusore / Diffuser

Vetro soffiato effetto
regolite
Blown glass with regolith
effect

Illuminazione / light source

LED 10W E14

 Dimmerabile con convertitore DALI su richiesta
Dimmable with DALI converter on request

 Utilizzo da interno
Indoor use

 Prodotto dimmerabile
Dimmable

Lampadina non compresa / Bulb not included.



Art. 5831/12+6+3

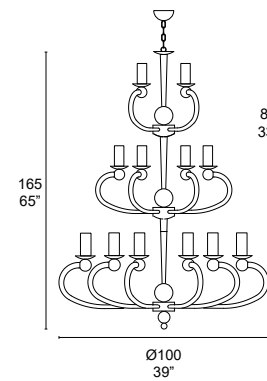

Art. 5831/12

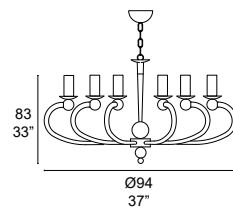

Art. 5831/8

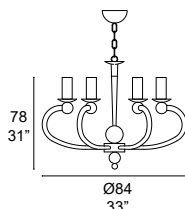

Art. 5831/5

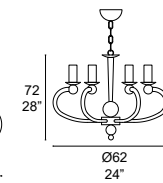

Art. 5831/A2

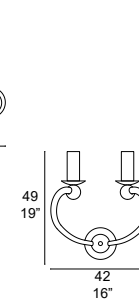

Art. 5831/A1

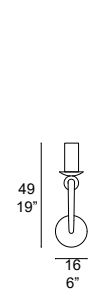

Art. 5831/LT1

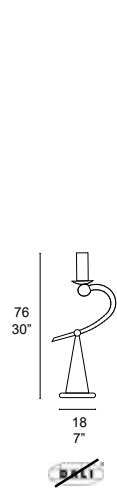

Fleur

LEAVES

Lampada in metallo foglia argento e cristalli gemma molati
Silver leaf metal lamp and smoothed crystal gems

Struttura / Frame

V2514
foglia argento con dettagli
anticati e madreperla
silver leaf with antique and
nacre detail

Diffusore / Diffuser

cristalli gemma
molati
smoothed crystal
gems

Illuminazione / light source

LED 20W E27 LED 10W E14

 Dimmerabile con convertitore DALI su richiesta
Dimmable with DALI converter on request

 Utilizzo da interno
Indoor use

 Prodotto dimmerabile
Dimmable

Lampadina non compresa / Bulb not included.

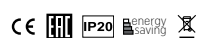

Art. 6891/6

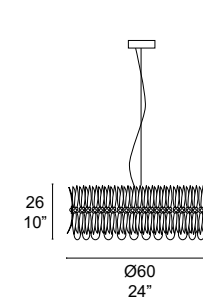

Art. 6891/A2

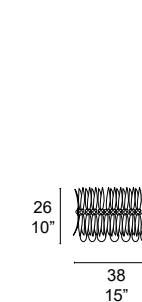

Art. 6891/L1



Art. 6891/LT1

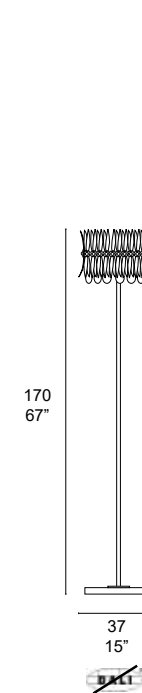

MANSION

Lampada in metallo brunito, vetro borosilicato e velluto
Burnished metal lamp, borosilicate glass and velvet

Struttura / Frame

V2962
Brunito galvanico
Galvanic burnished

Diffusore / Diffuser

Tessuto velluto
Velvet fabric

Illuminazione / light source

LED 10W E14

 Dimmerabile con convertitore DALI su richiesta
Dimmable with DALI converter on request

 Utilizzo da interno
Indoor use

 Prodotto dimmerabile
Dimmable

Lampadina non compresa / Bulb not included.



Art. 7433/5

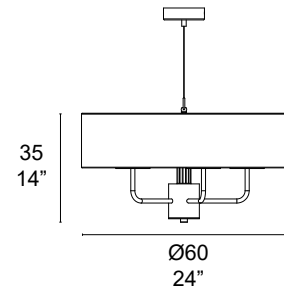

Fleur

NIK

Lampada in metallo decorato e paralumi
Painted metal lamp and borosilicate glass

Struttura / Frame

V2697
brunito sfumato
argento a pennello,
dettagli polvere argento
burnished nuanced
silver with brush,
silver powder details

V2698
avorio sfumato
oro a pennello,
dettagli polvere oro
ivory nuanced
gold with brush,
gold powder details

Diffusore / Diffuser

paralume avorio con
bordatura argento oro-
ivory lampshade with
silver gold hem

Illuminazione / light source

LED 10W E14

 Dimmerabile con convertitore DALI su richiesta
Dimmable with DALI converter on request

 Utilizzo da interno
Indoor use

 Prodotto dimmerabile
Dimmable

Lampadina non compresa / Bulb not included.

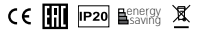

Art. 7032/8

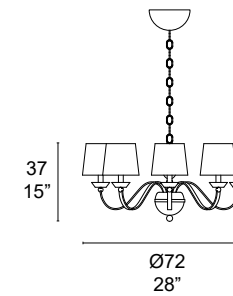

Art. 7032/5

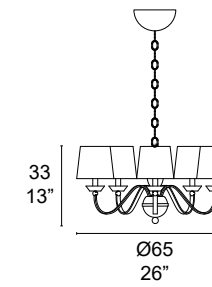

Art. 7032/A2

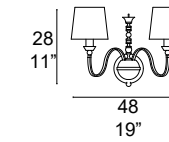

Art. 7032/A1

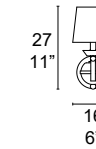

Art. 7032/L1

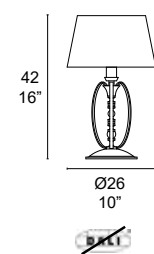

OTTOCENTO

Lampada in metallo decorato e cristalli
Painted metal lamp and crystals

Struttura / Frame

Diffusore / Diffuser

Illuminazione / light source

V2164
sfumatura a mano effetto
metallo invecchiato con
dettagli foglia oro
blurred by hand aged metal
effect with gold leaf details

 20W E27  10W E14

 Dimmerabile con convertitore DALI su richiesta
Dimmable with DALI converter on request

 Utilizzo da interno
Indoor use

 Prodotto dimmerabile
Dimmable

Lampadina non compresa / Bulb not included.



Art. 6419/8+4

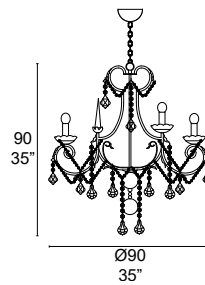

Art. 6419/6+3

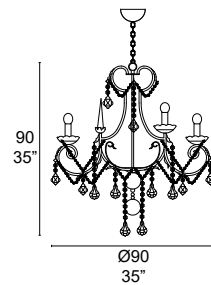

Art. 6419/A2

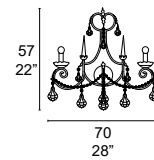

Fleur

PARIS

Lampada in metallo galvanico e paralumi
Galvanic metal lamp and lampshades

Struttura / Frame

Diffusore / Diffuser

Illuminazione / light source

V2544
argento lucido con
dettagli sfumati china
glossy silver with
cinchona nuanced
details

 paralume organza
bianco e nero
black and white or-
ganza lampshade

 10W E14

 Dimmerabile con convertitore DALI su richiesta
Dimmable with DALI converter on request

 Utilizzo da interno
Indoor use

 Prodotto dimmerabile
Dimmable

Lampadina non compresa / Bulb not included.

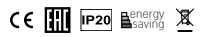

Art. 6906/3



Art. 6906/5

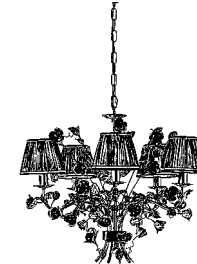

Art. 6906/12+6+3



Art. 6906/A1



Art. 6906/L1



Art. 6988/3

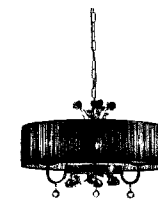

Art. 6988/6

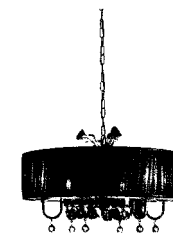

Art. 6988/A2

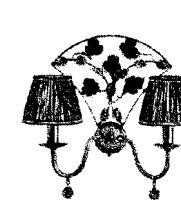

RUGIADA

Lampada in metallo decorato e vetro murano
Decorated metal lamp and murano glass

Struttura / Frame

V1669
foglia oro invecchiato
aged gold leaf

V1690
foglia argento invecchiata
aged silver leaf

Diffusore / Diffuser

vetro murano
cristallo bullè-
murano glass
bullè

Illuminazione / light source

20W E27 10W E14 5W G9

Dimmerabile con convertitore DALI su richiesta
Dimmable with DALI converter on request

Utilizzo da interno
Indoor use

Prodotto dimmerabile
Dimmable

Lampadina non compresa / Bulb not included.

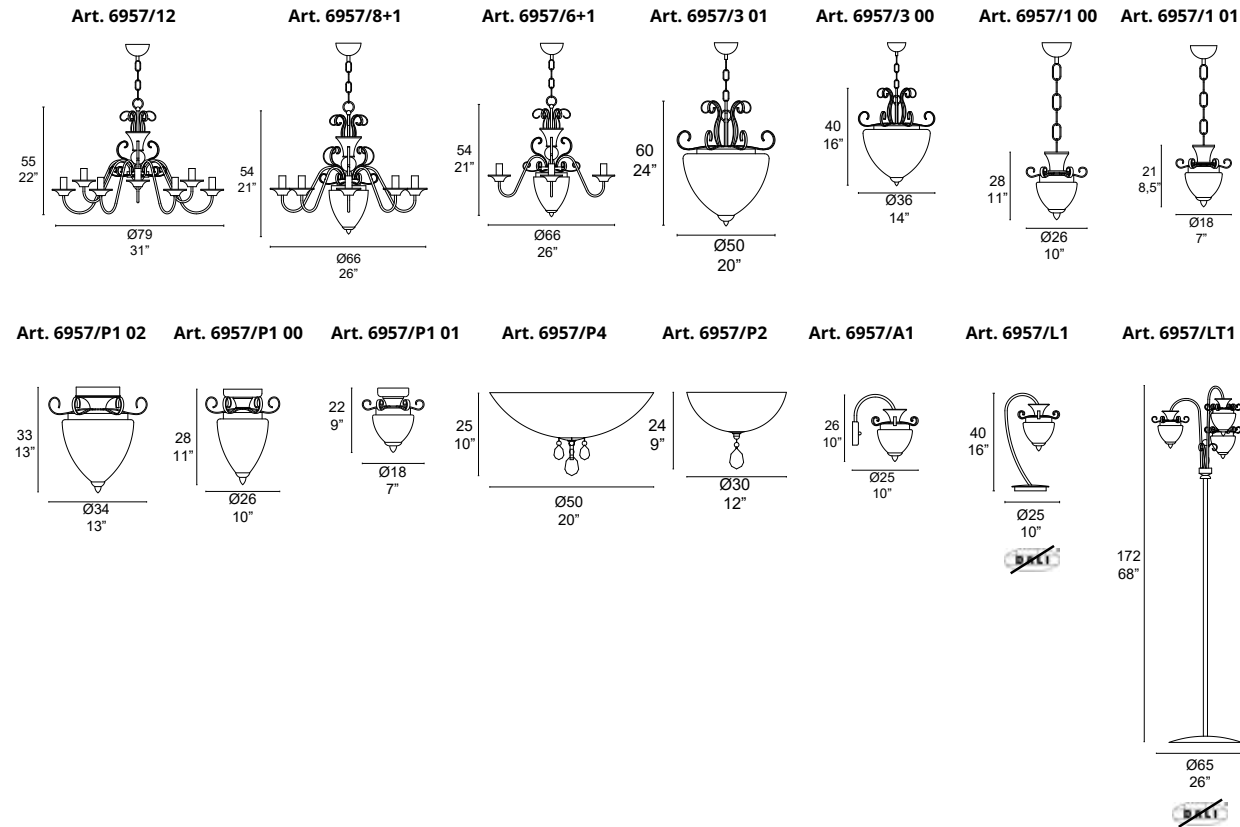

Fleur

SPARTA

Lampada in metallo verniciato e vetro a coste
Painted metal lamp and ribbed glass

Struttura / Frame

V2737
bianco decorato oro

V2968
brunito dettagli polvere oro
burnished gold dust details

Diffusore / Diffuser

vetro murano
cristallo a coste con
granulato di vetro-
striped murano glass
with glass nuggets

Illuminazione / light source

20W E27

Dimmerabile con convertitore DALI su richiesta
Dimmable with DALI converter on request

Utilizzo da interno
Indoor use

Prodotto dimmerabile
Dimmable

Lampadina non compresa / Bulb not included.

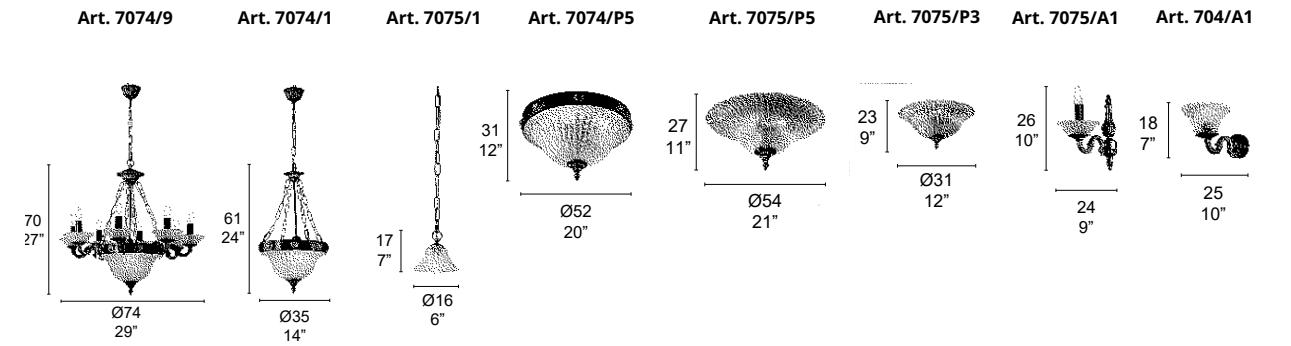
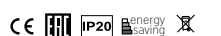

STALLATTITE

Lampada in metallo foglia oro e vetro colato
Gold-leaf metal lamp and poured glass

Struttura / Frame

V1669
foglia oro invecchiato
aged gold leaf

Diffusore / Diffuser

vetro colato martellato
hammered poured glass

Illuminazione / light source

LED 20W E27



Dimmerabile con convertitore DALI su richiesta
Dimmable with DALI converter on request



Utilizzo da interno
Indoor use



Prodotto dimmerabile
Dimmable

Lampadina non compresa / Bulb not included.



Art. 6609/2+1

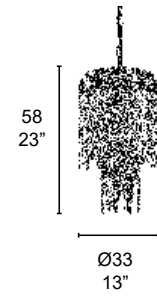

Art. 6609/A1

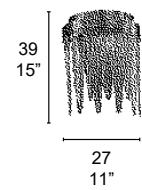

Fleur

STELO

Lampada in metallo verniciato con paralume
Painted metal lamp with lampshade

Struttura / Frame

V2720
verniciato alluminio invecchiato
painted aged aluminum

Diffusore / Diffuser

paralume
lampshade

Illuminazione / light source

LED 20W E27 LED 10W E14



Dimmerabile con convertitore DALI su richiesta
Dimmable with DALI converter on request



Utilizzo da interno
Indoor use



Prodotto dimmerabile
Dimmable

Lampadina non compresa / Bulb not included.



Art. 7069/8

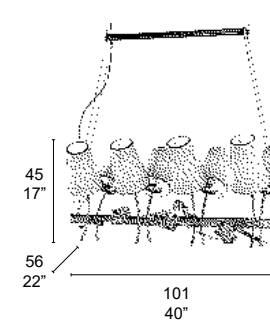

Art. 7069/A1

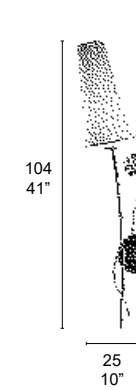

Art. 7069/L1



Art. 7069/L1 01



Art. 7069/LT1

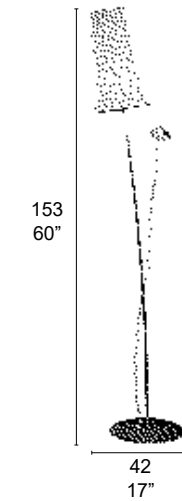

TOPAZIO

Lampada in metallo verniciato e vetro
Painted metal lamp and glass

Struttura / Frame

V1165
oro antico verniciato
antique gold painted

Diffusore / Diffuser

○ triedri cristallo
triedro crystal

Illuminazione / light source

LED 10W E14

 Dimmerabile con convertitore DALI su richiesta
Dimmable with DALI converter on request

 Utilizzo da interno
Indoor use

 Prodotto dimmerabile
Dimmable

Lampadina non compresa / Bulb not included.

Art. 7135/12

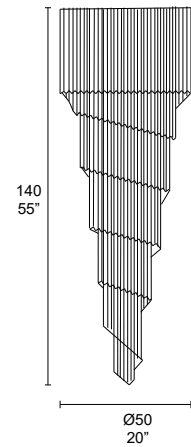

Art. 7135/10

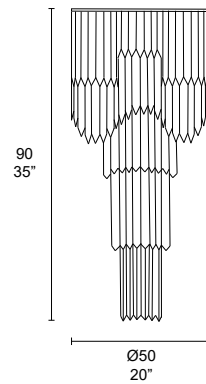

Art. 7135/P5

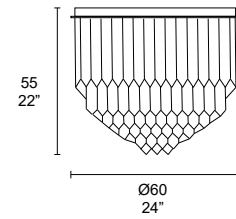

Fleur

TRAMA

Lampada in metallo galvanico e vetro colato
Painted metal lamp and poured glass

Struttura / Frame

V1607
Cromo lucido
Glossy chrome

Diffusore / Diffuser

○ Vetro colato con trama
Cast glass with texture

Illuminazione / light source

LED 10W E14

 Dimmerabile con convertitore DALI su richiesta
Dimmable with DALI converter on request

 Utilizzo da interno
Indoor use

 Prodotto dimmerabile
Dimmable

Lampadina non compresa / Bulb not included.

Art. 7071/A2

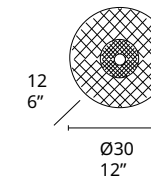

Art. 7071/A4

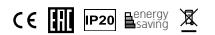
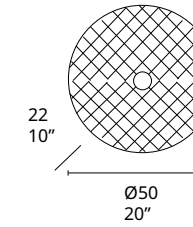

VILLA

Lampada in metallo decorato e pendenti in vetro
Decorated metal lamp and glass pendants

Struttura / Frame

Diffusore / Diffuser

V1959
Base marrone scuro con foglia
oro e argento anticati screpolati
Dark brown base with cracked
antiqued gold and silver leaf

Illuminazione / light source



Dimmerabile con convertitore DALI su richiesta
Dimmable with DALI converter on request



Utilizzo da interno
Indoor use



Prodotto dimmerabile
Dimmable

Lampadina non compresa / Bulb not included.



Art. 4819/8

Art. 4819/5

Art. 4819/3

Art. 4819/A2



Fleur

ICONE

ICONS



Utilizzo da interno
Indoor use



Utilizzo da esterno
Outdoor use



Prodotto dimmerabile
Dimmable



Tensione d'uso
Voltage



Tensione d'uso
Voltage



Lampadina a LED sostituibile
Replaceable LED bulb



Modulo LED integrato non sostituibile
Integrated non-replaceable LED module



Modulo LED integrato sostituibile
Integrated replaceable LED module



Prodotto conforme ai requisiti essenziali per la commercializzazione ed utilizzo nell'Unione Europea.
Product in compliance with the essential requirements for the marketing and use in the European Union.



Prodotto conforme a tutte le normative tecniche delle procedure di valutazione dell'Unione doganale eurasiatica.
Product complies with all technical regulations of the Eurasian Customs Union evaluation procedures.



Prodotto orientabile
Swiveling Product



Peso netto
Net weight



Peso lordo
Gross weight



Non protetto contro l'ingresso di liquidi
Not protected against liquids permeation



Dimmerabile con convertitore DALI su richiesta
Dimmable with DALI converter on request

LAMPADINE

BULBS

Type	Lampadine led / Led bulbs	Watt
E14		10W
E27		20W
G9		5W
Gx53		8W
GU 10		15W

VISUAL DIRECTION AND STYLING

GIORGIO BISCARO
M.M. LAMPADARI

STUDIO PRODUCTION, SET DESIGN & STYLING

M.M. LAMPADARI
STUDIO ROCCI
GIORGIO BISCARO

PHOTOGRAPHY

DITRE
EMANUELE SURIAN
STUDIO ROCCI

COLOUR CALIBRATION

GM STUDIO1

TUTTI I PRODOTTI MM LAMPADARI S.R.L. SONO CONFORMI ALLE DIRETTIVE EUROPEE IN VIGORE. OGNI ARTICOLO PRODOTTO PRESENTATO NEL CATALOGO É REALIZZATO E DECORATO ARTIGIANALMENTE, PERTANTO LIEVI DIFFERENZE NELLE DIMENSIONI, NEL COLORE O NEI DETTAGLI COSTITUIRANNO IL CARATTERE DI UNICITÀ PROPRIO DELLA LAVORAZIONE MANUALE.

ALL MM LAMPADARI S.R.L. PRODUCTS COMPLY WITH THE EUROPEAN DIRECTIVES IN FORCE. EACH PRODUCT PRESENTED IN THE CATALOGUE IS PRODUCED AND DECORATED BY HAND; THEREFORE, SLIGHT COLOUR, SIZE OR DETAIL DIFFERENCES WILL MAKE THE UNIQUE CHARACTER IN THE HANDWORK.

MM LAMPADARI S.R.L. SI RISERVA IL DIRITTO DI INTERVENIRE IN QUALUNQUE MOMENTO E SENZA PREAVVISO PER APPORTARE LE MODIFICHE CHE RITENESSE PIÙ OPPORTUNE PER MIGLIORARE IL PRODOTTO O IN RISPOSTA A QUALSIASI ESIGENZA DI CARATTERE NORMATIVO COSTRUTTIVO O COMMERCIALE.

MM LAMPADARI S.R.L. RESERVES ITS RIGHT TO INTERVENE IN EVERY MOMENT AND WITHOUT FOREWARNING IN ORDER TO MAKE THE MODIFICATIONS MORE SUITABLE TO IMPROVE THE PRODUCT OR REPLY TO EACH LEGAL, MANUFACTURING OR COMMERCIAL REQUIREMENT.



© M.M. LAMPADARI. È VIETATA LA RIPRODUZIONE ANCHE PARZIALE DI QUESTO CATALOGO

© M.M. LAMPADARI. IT IS FORBIDDEN TO REPRODUCE ANY PART OF THIS CATALOGUE

RIEDIZIONE APRILE 2025
REISSUE APRIL 2025



mmlampadari

Via Feltrina 37 , 31040 Pederobba (TV) Italy
Email: mmlampadari@mmlampadari.com Web: www.mmlampadari.com Tel. +39 0423 688800



mmlampadari