

MARQUISE

2025

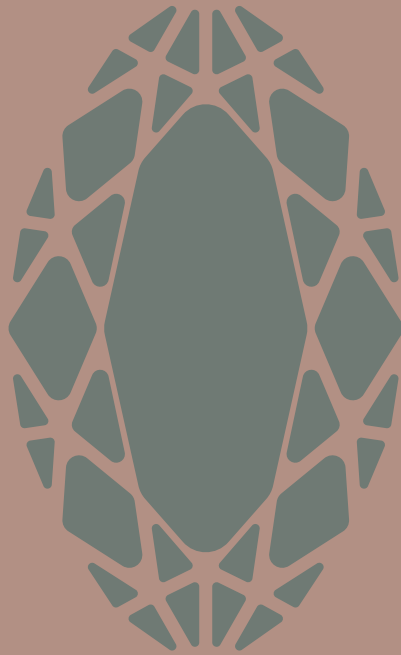

mmlampadari

MARQUISE

Per la nuova edizione del nostro catalogo, abbiamo superato la tradizionale dicotomia tra Classico e Design e la nostra dedizione al prodotto ci ha spinto a ridefinire le collezioni trasformandole in visioni. Vogliamo offrire un'esperienza di prodotto che vada oltre l'attribuzione di un aggettivo coinvolgendo profondamente l'osservatore.

Il catalogo che avete tra le mani è il risultato di una meticolosa revisione del patrimonio creativo di MM Lampadari. Ogni pagina riflette l'habitat, la personalità e lo stile di vita che abbiamo immaginato per i nostri clienti.

La collezione Marquise rappresenta il culmine di questo processo: dettagli rigorosi, lucentezza diamantina e riflessi preziosi.

Questa collezione ospita i nostri prodotti più raffinati ed eleganti, fondendo la tradizione luminosa italiana con un'interpretazione moderna e senza tempo. Un taglio preciso e netto affina la materia grezza, trasformando ogni pezzo in un capolavoro luminoso, familiare e rassicurante nella sua rigidità formale.

For the new edition of our catalog, we have transcended the traditional dichotomy between Classical and Design. Our dedication to the product has driven us to redefine our collections, transforming them into visions. We aim to offer a product experience that goes beyond mere adjectives, deeply engaging the observer.

The catalog you hold in your hands is the result of a meticulous revision of MM Lampadari's creative heritage. Each page reflects the habitat, personality, and lifestyle we envision for our clients.

The Marquise collection represents the pinnacle of this process: rigorous details, diamond-like brilliance, and precious reflections.

This collection showcases our most refined and elegant products, blending the luminous Italian tradition with a timeless modern interpretation. A precise and sharp cut refines the raw material, transforming each piece into a luminous masterpiece, familiar and reassuring in its formal rigor.

DA OLTRE 50 ANNI, PLASMIAMO LA MATERIA IN CAPOLAVORI DI LUCE

Da oltre cinquant'anni, MM Lampadari porta avanti l'eccellenza nell'illuminazione d'interni, combinando abilmente tradizione e innovazione. Specializzati nel lavoro del metallo e del vetro, creiamo lampade uniche che riflettono stile e passione. La nostra collezione esclusiva, frutto della collaborazione familiare con la vetreria, offre pezzi unici, dalla raffinata lavorazione del vetro di Murano alle soluzioni innovative in materiali tecnologici. Siamo impegnati a garantire valore attraverso prodotti e servizi di alta qualità, mantenendo viva l'arte dell'illuminazione.

Inoltre, MM Lampadari lavora anche nel settore contract, offrendo articoli custom e prodotti su disegno, adattabili alle esigenze specifiche dei nostri clienti. Con MM Lampadari, ogni ambiente si trasforma in uno scenario unico e suggestivo, dove la luce diventa un'arte che ispira e emoziona.

FOR OVER 50 YEARS, WE'VE SHAPED MATERIALS INTO MASTERPIECES OF LIGHT

For over fifty years, MM Lampadari has been a beacon of excellence in interior lighting, skillfully combining tradition and innovation. Specializing in metal and glasswork, we create unique lamps that reflect style and passion. Our exclusive collection, born from a family collaboration with the glassworks, offers unique pieces, from the refined craftsmanship of Murano glass to innovative solutions in high-tech materials. We are dedicated to providing value through high-quality products and services, keeping the art of lighting alive.

Additionally, MM Lampadari also operates in the contract sector, offering custom items and bespoke products tailored to the specific needs of our clients. With MM Lampadari, every environment is transformed into a unique and evocative setting, where light becomes an art that inspires and captivates.



INNOEX



AMANITA 12



BABILONIA 18



CURL 24



PERLA 92



RAYS 96



PETAL 102



CUSPIDE 30



OPUS 38



TUMBLER 44



SASS 108



JACK 114



BUCCIA 120



FONTAINE 54



PILL 60



MYA 66



CITY 126



FILI 132



MUSEO 138



ARABESQUE 74



GOCCIA 82



1920 88



SKY 144



ORION 150

INDEX

1920	88	MUSEO	138
AMANITA	12	MYA	66
ARABESQUE	74	OPUS	38
BABILONIA	18	ORION	150
BUCCIA	120	PERLA	92
CITY	126	PETAL	102
CURL	24	PILL	60
CUSPIDE	30	RAYS	96
FILI	132	SASS	108
FONTAINE	54	SKY	144
GOCCIA	82	TUMBLER	44
JACK	114		
SPECIFICHE TECNICHE	158		
TECHNICAL DETAILS	158		

AMANITA

DESIGNED BY MM LAMPADARI WORKSHOP



AMANITA

Amanita è un oggetto-scultura che assume una forma astrattamente organica. Quando viene accesa, si arricchisce di sottili dettagli che esaltano i suoi spessori variabili. Questi dettagli si diffondono lungo l'altezza del suo generoso corpo in vetro di Murano bianco latte, creando un'aura luminosa, elegante e soffusa. I lussuosi tocchi di metallo aggiungono un tocco di raffinata magnificenza, completando un capolavoro di luce e design.

Amanita is an object sculpture that takes on an abstractly organic form. When lit, it is enriched with subtle details that highlight its varying thicknesses. These details spread along the height of its generous body in white Murano glass, creating a luminous, elegant, and soft aura. Luxurious metal touches add a refined magnificence, completing a masterpiece of light and design





BABILONIA

DESIGNED BY MM LAMPADARI WORKSHOP



BABILONIA

La precisa geometria di questo oggetto richiama profondamente l'architettura antica, esemplificando un senso di imponente proporzione. Il solido diffusore vitreo a base quadrata evoca le forme classiche, con striature verticali che conferiscono verticalità, ordine e rigore. Un secondo diffusore LED interno funge da guida ottica, diffondendo la luce attraverso tutto il volume con raffinata eleganza.

The precise geometry of this object deeply echoes ancient architecture, exemplifying a sense of imposing proportion. The solid glass diffuser with a square base evokes classical forms, with vertical striations that impart verticality, order, and rigor. An internal LED diffuser acts as an optical guide, elegantly spreading light throughout the entire volume





CURL

DESIGNED BY GIORGIO BISCARO



CURL

Curl celebra la vittoria della tecnica sulla materia con la sua solida struttura in metallo curvato, che supporta un elegante diffusore in tessuto tramato color cioccolato. Questo raffinato diffusore, caldo e accogliente, lascia trasparire le sorgenti luminose. Al centro, come un faro splendente, un elemento in vetro borosilicato cannettato conferisce verticalità alla lampada, ricevendo e moltiplicando la luce come un prezioso gioiello

Curl celebrates the triumph of simplicity in combining materials. A solid curved metal structure supports an elegant translucent diffuser woven in chocolate color. This refined diffuser, warm and inviting, allows the light sources to shine through. At the center, like a radiant beacon, a fluted borosilicate glass element imparts verticality to the lamp, capturing and multiplying the light like a precious jewel.





CUSPIDE

DESIGNED BY MM LAMPADARI WORKSHOP



CUSPIDE

Una rappresentazione schematica di un'intersezione tra figure geometriche: lineare, solida, rigidamente metallica, eppure ingentilita da delicati diffusori in vetro. Questi diffusori di vetro Murano cristallo satinato interno con rigatura verticale che li rende setosi all'apparenza, evocano quasi un manufatto tessile. L'alta arte vetraria incontra la raffinata lavorazione del metallo in finitura brunito galvanico, artigianalmente conformato in un elegante connubio di luce e materia.

Cuspide Family is a schematic representation of the intersection between geometric figures: linear, solid, rigidly metallic, but softened by delicate glass diffusers. These diffusers are made of Murano glass with an internal satin crystal finish and vertical streaks that make them silky, almost like a textile article. The high art of glass processing meets the refined craftsmanship of metalworking in burnished galvanic finish, handcrafted in an elegant combination of light and material.







OPUS

DESIGNED BY GIORGIO BISCARO



OPUS

Un oggetto sospeso composto, rigoroso, persino duro nei suoi elementi costitutivi, che esprime attraverso il consistente uso del metallo una completa finitezza formale. Una lampada che si auto definisce e si rende evidente, i cui dettagli puntuti compongono una corazza lucente che sembra quasi essere stata messa a difesa dal mondo esterno.

A composed suspended object, rigorous, even hard in its constituent elements, which expresses complete formal finiteness through the consistent use of metal. A lamp that defines itself and makes itself evident, whose pointed details make up a shiny armor that almost seems to have been defended from the outside world.





TUMBLER

DESIGNED BY DANIELE LOSCALZO MOSCHERI



TUMBLER

In una combinazione di riferimenti visivi che ci suggeriscono il raffinato mondo della mixology, la famiglia Tumbler fa sfoggio di elementi da quello mutuati: le preziose molature e le lucenti finiture galvaniche abbinate all'eleganza del nero opaco fanno di ogni creazione un'opera d'arte da ammirare. E da degustare.

In a combination of visual references that suggest the refined world of mixology, the Tumbler family shows off elements borrowed from it: the precious grinding and the shiny galvanic finishes combined with the matte black elegance make each creation a work of art to to admire. And to taste.









FONTAINE

DESIGNED BY GIORGIO BISCARO



FONTAINE

Quasi la raffigurazione simbolica di una fontana che zampilla, congelata nell'istante in cui i getti d'acqua creano i tipici luccicanti rivoli, Fontaine fa della trasparenza e della moltiplicazione della luce la sua *raison-d'être*, anche grazie alle sferette di vetro che sostengono visivamente i diffusori soffiati a bocca in una elegante colorazione acciaio.

*Almost the symbolic representation of a gushing fountain, frozen in the instant in which the jets of water create the typical glittering rivulets, Fontaine makes transparency and the multiplication of light its *raison-d'être*, also thanks to the glass spheres which visually support the mouth-blown diffusers in an elegant steel colour.*



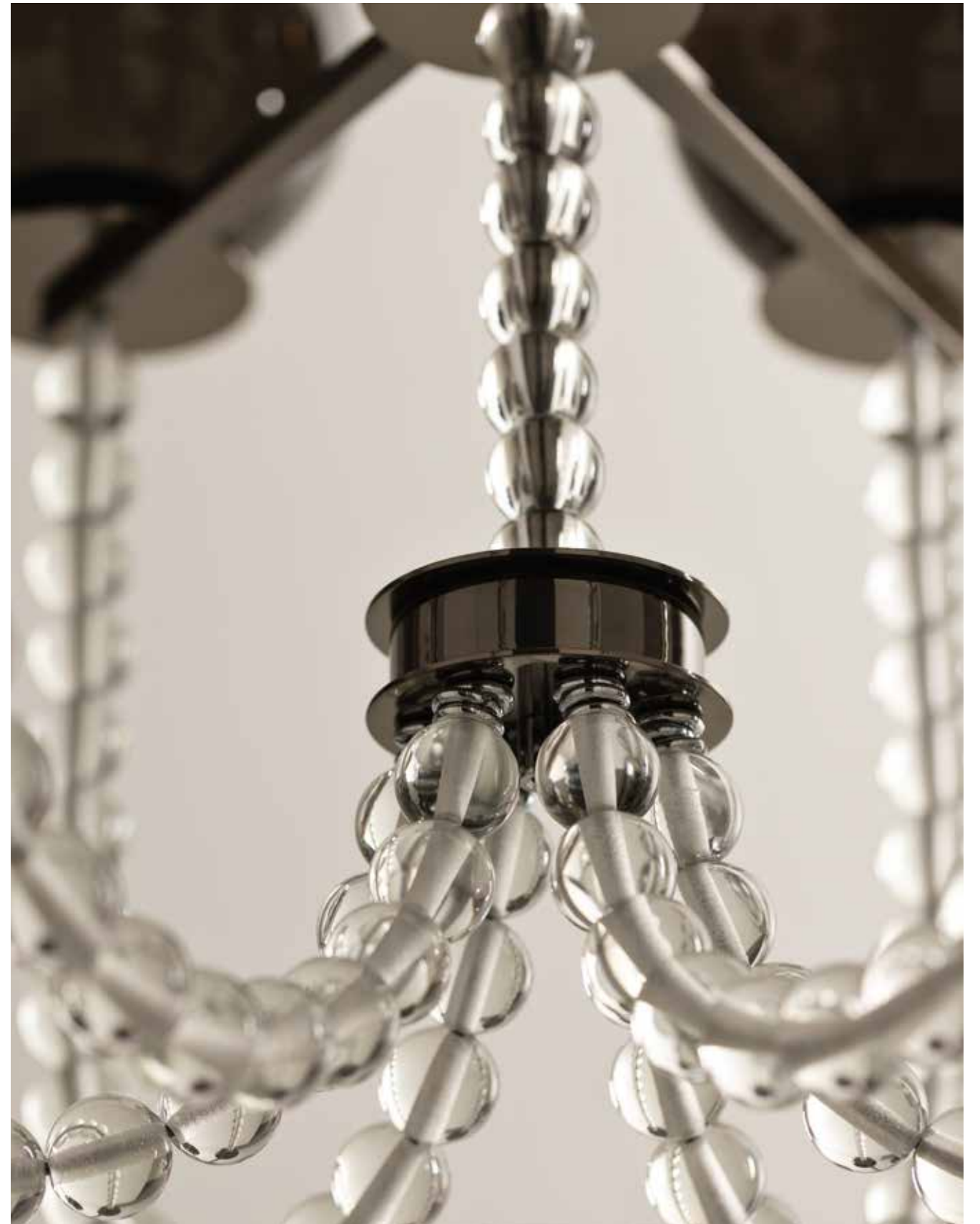

PILL

DESIGNED BY MATTEO ZORZENONI



PILL

Questa serie di lampade è un omaggio alle antiche tecniche di lavorazione del vetro di Murano. La parte superiore con soffiatura su stampo e la parte inferiore con soffiatura a mano libera in gabbia metallica eseguita da Maestri vetrai. Connubio indissolubile tra la struttura in metallo e il vetro di Murano che sembrano abbracciarsi e quasi fondersi in un'unica entità e produrre un effetto etereo e di estrema eleganza.

Wink at Op-Art this family of chandeliers in light metal rods that enhance the stripes, transforming them into a geometric and decorative element full of simplicity and freshness. This is how Fili, in its different forms, celebrates the stripes effect. Direct lighting from above emphasises its forms and makes it a lamp with a timeless taste.





MYA

DESIGNED BY LENZIA MONDIN



MYA

Lampada a sospensione con struttura metallica e diffusori multipli in vetro. La grande articolazione del telaio compone una geometria complessa e radicale, sulla quale si innestano i corpi illuminanti in vetro decorato. Chiaro rimando alle sfarzose strutture architettoniche d'epoca Art Deco, il lampadario allude facilmente anche a stilemi precolombiani, rimarcati dalle evidenti spigolosità delle strutture metalliche.

Suspension lamp with metal structure and multiple glass diffusers. With its complex and radical geometric design, the pendant lamp Mya makes for a sublime addition to contemporary decors (with a retro twist). Inspired by Art Deco, it also alludes to pre-Columbian stylistic elements as the sharp-edged metal structure underlines.







ARABESQUE

DESIGNED BY MM LAMPADARI WORKSHOP



ARABESQUE

La raffinatezza e sofisticatezza del vetro soffiato di Murano si sposano con gli ornamenti che trasmettono serenità e bellezza. È così che la serie di lampade Arabesque omaggia un'arte antica del bello declinandola in tutte le sue forme e dove protagonisti diventano i dettagli ed i riflessi che la luce trasmette.

The refinement and sophistication of Murano blown glass are combined with the ornaments that convey serenity and beauty. This is how the Arabesque series of lamps pays homage to an ancient art of beauty, declined in all its forms and where the protagonists become the details and reflections that light transmits.





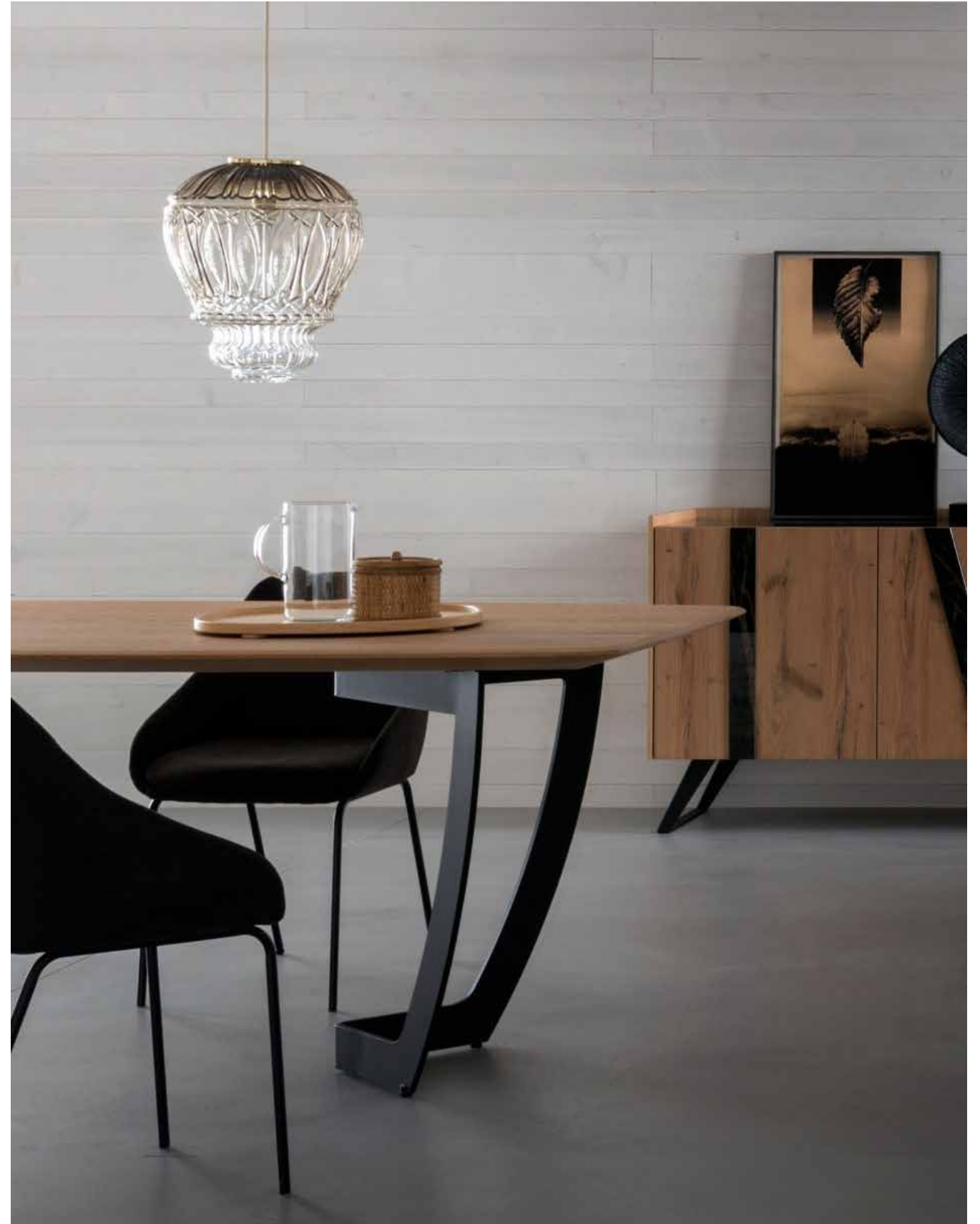

GOCCIA

DESIGNED BY MM LAMPADARI WORKSHOP



GOCCIA

Sospensione ad una luce realizzata in vetro soffiato a mano secondo la tradizione dei maestri vetrai di Murano. La lampada è completata da un pendente in metallo che la rende longilinea e fluida.

Suspension with one light realized with hand-blown glass as per tradition of glass masters of Murano. The lamp is completed with a metal drop that makes it smooth and slender.





1920

DESIGNED BY CHRISTIAN PICCOLO



1920

Sintetico e plastico nelle forme, il classico tubo metallico viene sagomato per ricordare il classico pattern dell'Art Decò. Il corpo centrale in metallo chiuso da un disco in PMMA sabbiato, direziona la luce in maniera uniforme. Nelle applique il diffusore può essere ruotato.

Synthetic and plastic in his form, the classic metal tube is shaped to recall the classic pattern of Art Deco. The metal central body closed by a sandblasted PMMA disc, direct the light uniformly. In the applique the diffuser can be rotated.



PERLA

DESIGNED BY CHRISTIAN PICCOLO



PERLA

Perla, lampada da parete dai tratti semplici ed al contempo distintivi. Due elementi in vetro uniti da un filo di metallo sono abbinabili nelle finiture bianco lucido, coprente ottonato o cemento per avere un effetto luce half oppure quarter moon.

Pearl, a wall lamp with simple but distinctive features. Two glass elements joined by a metal wire can be combined in glossy white, brass or concrete finishes to have a half moon or quarter moon light effect.



RAYS

DESIGNED BY MATTEO ZORZENONI



RAYS

Chiamata così per la rifrazione della luce donata dal vetro classico di Murano, Rays con la sua struttura in metallo circolare e top in vetro soffiato effetto balloton sostenuto da bracci radiali reinterpreta in chiave contemporanea lo stile essenziale e di ricerca del medioevo che faceva della luce il principale elemento di decorazione di interni.

Named after the refraction of light given by classic Murano glass, Rays, with its circular metal structure and top in blown glass with a balloton effect supported by radial arms, reinterprets in a contemporary way the essential style and research of the Middle Ages that made light the main element of interior decoration.





PETAL

DESIGNED BY STUDIO MAMMINI CANDIDO



PETAL

Lampada da parete,
dalla forma elegante
e dalle linee pulite
proposta in due misure.
Arreda ogni superficie
in cui viene installata
con libertà e fantasia,
come se fosse un vero
e proprio giardino. La
sua superficie materica
la rende viva e vivace,
alla stregua di un petalo
di fiore mosso dal vento
e conferisce dinamicità
e raffinatezza ad ogni
ambiente in cui si trova.

*Wall lamp, with an elegant
shape and clean lines,
available in two sizes. It
furnishes every surface
where it is installed with
freedom and imagination,
as if it were a real garden.
Its material surface makes
it alive and lively, like a
flower petal moved by the
wind and gives dynamism
and refinement to every
environment in which it is
found.*





Le finiture di questa collezione sono di natura artigianale, rifinite a mano; prevedono variazioni e naturali imperfezioni nel risultato finale. Non potranno esistere perciò due prodotti identici.

The finishes in this collection are handcrafted, they involve variations and natural imperfections in the final result. Therefore, there cannot be two identical products.

SASS

DESIGNED BY MM LAMPADARI WORKSHOP

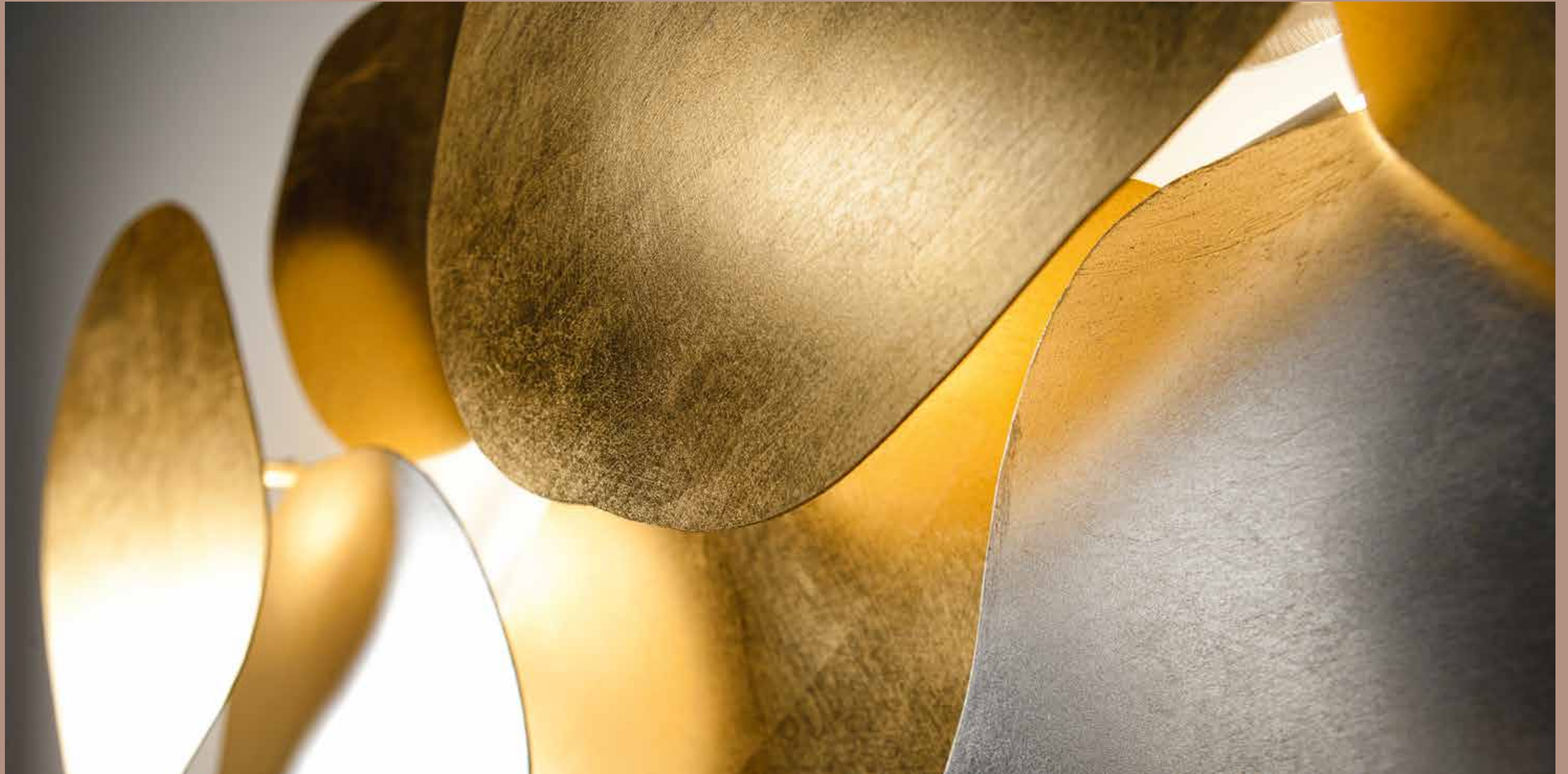

SASS

Lampade che si possono adattare sia a soffitto che a parete; sono realizzate con lamiere modulate in metallo, adagiate a creare quasi una scultura e decorate in foglia oro e foglia argento.

Lamps that can be used as ceiling or wall lamp; realized with metal sheet, positioned to create almost a sculpture, and finished in gold and silver leaf.





JACK

DESIGNED BY OLGA ENGEL



JACK

Lo stile neoclassico ed impero ispirano questa lampada che trasforma gli elementi decorativi in cristallo di forma geometrica ed allungata in un motivo ripetuto e circolare installato però in orizzontale ed in metallo arricchendo Jack di nuovi giochi di luce.

La sua struttura cinetica permette di spostare alcune delle sue parti, cambiandone così il suo diametro e conferendole un design in continua evoluzione.

The neoclassical and empire style inspires this lamp that transforms the decorative crystal elements of geometric and elongated shape into a repeated and circular motif installed horizontally and in metal, enriching Jack with new plays of light. Its kinetic structure allows moving some of its parts, thus changing its diameter and giving it a continuously evolving design.





BUCCIA

DESIGNED BY MM LAMPADARI WORKSHOP



BUCCIA

Uno spiccato gusto
etnico sapientemente
rivisitato in chiave
moderna con metallo
lavorato a sbalzo e rifinito
in foglia oro.

Luce contemporanea
con un sapore
tradizionale.

*A strong ethnical look,
wisely revisitated
in modern key with
embossed work metal
and finished in gold leaf.
Contemporary light with a
traditional taste.*





CITY

DESIGNED BY ENRICO DE GIRARDI



CITY

La serie City presenta bande metalliche bruciate a fiamma e forgiate al maglio, componendosi in forme circolari o squadrate. Queste lamiere, lavorate nella nostra fucina, sono poi decorate con foglia oro e foglia argento. Per plasmare movimento e giochi di luce, la struttura è impreziosita da inserti in vetro soffiato o colato a mano

The City series features metal bands that are flame-burned and hammer-forged, forming circular or squared shapes. These sheets, crafted in our forge, are then decorated with gold and silver leaf. To shape movement and light play, the structure is adorned with hand-poured or blown glass inserts.





FILI

DESIGNED BY CHRISTIAN PICCOLO



FILI

Strizza l'occhio alla Op-Art questa famiglia di chandelier in tondini metallici leggeri che esaltano le righe trasformandole in elemento geometrico e decorativo pervaso di semplicità e freschezza. Ecco come Fili nelle sue diverse forme celebra l'effetto millerighe. Una illuminazione diretta che arriva dall'alto ne enfatizza le forme e la rende una lampada dal gusto senza tempo.

Wink at Op-Art this family of chandeliers in light metal rods that enhance the stripes, transforming them into a geometric and decorative element full of simplicity and freshness. This is how Fili, in its different forms, celebrates the stripes effect. Direct lighting from above emphasises its forms and makes it a lamp with a timeless taste.





MUSEO

DESIGNED BY MM LAMPADARI WORKSHOP



MUSEO

Lampade in foglia oro adibite ad una funzione precisa; da utilizzare sopra specchio sopra quadri; sono impreziosite all'estremità da cristalli Swaroski.

Lamps in gold leaf suitable for mirrors and pictures. They are made precious at the edges by Swaroski crystals.



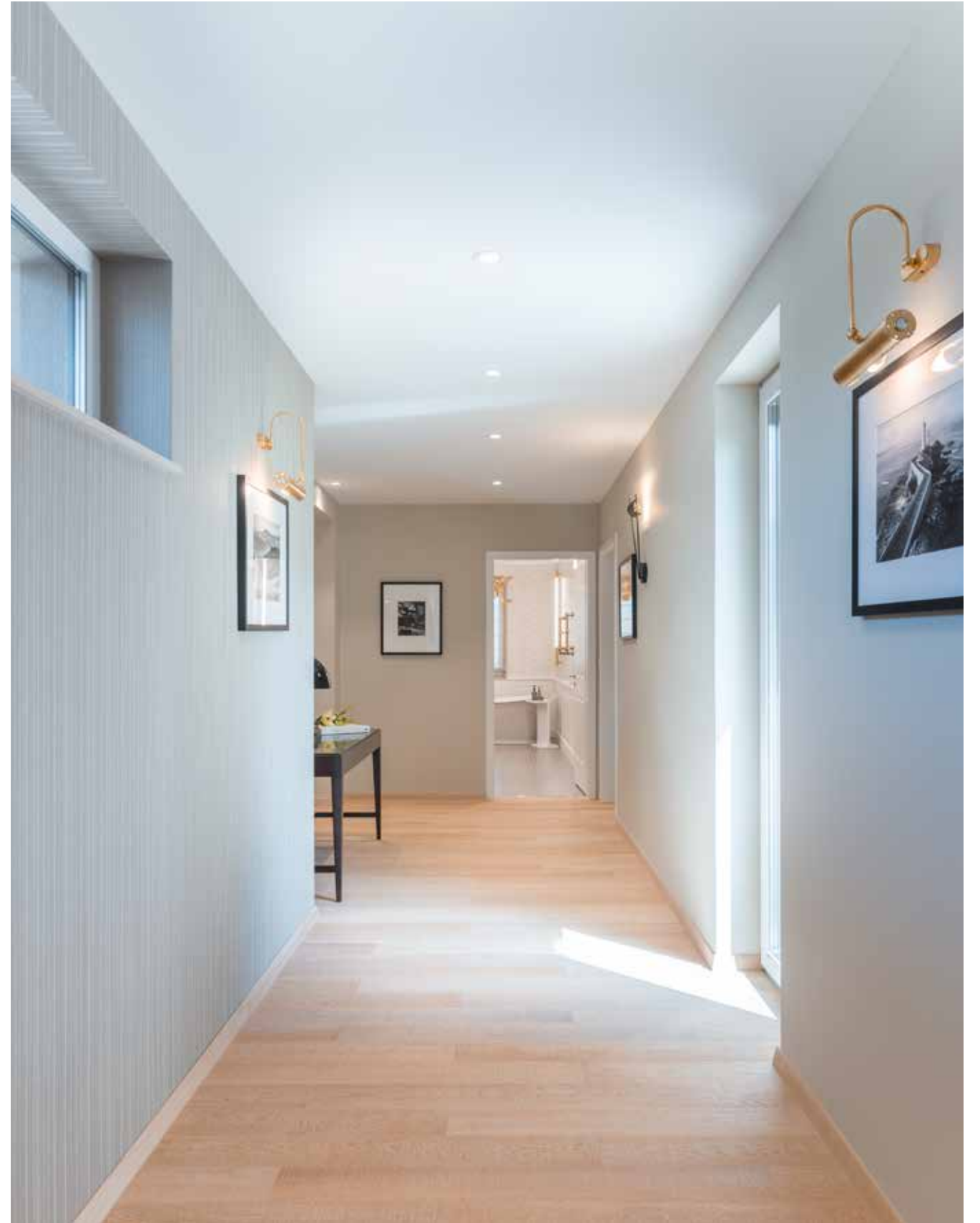

SKY

DESIGNED BY MM LAMPADARI WORKSHOP



SKY

Serie di lampade a parete e da terra, a forma arcuata, realizzate artigianalmente e rifinite con foglia oro e foglia argento applicate a mano. La linearità della collezione si sposa con la ricercatezza della lavorazione, creando un binomio moderno/classico che si integra armoniosamente in ogni tipo di ambiente.

A series of wall and floor lamps, with an arched shape, handcrafted and finished with hand-applied gold and silver leaf. The linearity of the collection blends with the sophistication of the craftsmanship, creating a modern/classic combination that integrates harmoniously into any type of environment.





ORION

DESIGNED BY MM LAMPADARI WORKSHOP



ORION

Linee geometriche ed essenziali caratterizzano la serie Orion. La struttura, realizzata con elementi a sezione rettangolare e diffusori in tessuto, è impreziosita da passamaneria con motivi dorati, applicata con cura artigianale. Su richiesta, è disponibile anche senza passamaneria.

Geometric and essential lines characterize the Orion series. The structure, made with rectangular section elements and fabric diffusers, is embellished with gold-patterned trimming, carefully applied by hand. Upon request, it is also available without trimming.







1920

Lampada in Metallo e PMMA
Lamp in Metal and PMMA

Struttura / Frame

- V2828
Canna di fucile verniciato
Gun metal grey painted
- V2945
Nickel
Nickel

Diffusore / Diffuser

- PMMA satinato
PMMA satin-finished

Illuminazione / light source

LED BOARD 6,1W 110/240V 983lm 3000K



Utilizzo da interno
Indoor use



Prodotto dimmerabile
Dimmable



Tensione d'uso
Voltage



Modulo LED integrato sostituibile
Integrated replaceable LED module



Art. 7388/A1

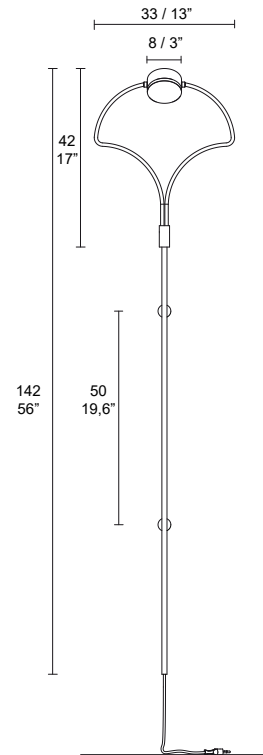

Marquise

AMANITA

Lampada vetro di Murano e metallo
Murano glass lamp and metal

Struttura / Frame

- V0216
Ottone lucido
Glossy brass

Diffusore / Diffuser

- vetro bianco latte lucido
milky white glass

Illuminazione / light source

- LED 10W E14



Utilizzo da interno
Indoor use



Prodotto dimmerabile
Dimmable

Lampadina non compresa / Bulb not included.



Art. 7425/L2

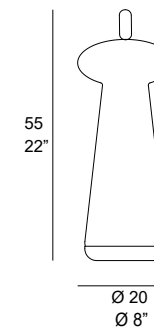

ARABESQUE

Lampada in Vetro Murano colorato in pasta e metallo
Murano glass lamp with coloured mixture at the origin, and metal

Struttura / Frame

V2553
Bianco lucido
Glossy White

V1607
Chromo lucido
Glossy chrome

Diffusore / Diffuser

Bianco lucido
Glossy white

Tortora sfumato-
Shaded taupe

Illuminazione / light source

LED 20W E27 LED 10W E14 5W G9

 Dimmerabile con convertitore DALI su richiesta
Dimmable with DALI converter on request

 Utilizzo da interno
Indoor use

 Prodotto dimmerabile
Dimmable

Lampadina non compresa / Bulb not included.



Marquise

BABILONIA

Lampada vetro Murano rigato,colorato in pasta e metallo
Striped Murano glass lamp with coloured mixture at the origin, and metal

Struttura / Frame

V 2833
Nickel nero
Black nickel

Diffusore / Diffuser

Vetro rigato bronzo
Bronze rimmed-glass

Illuminazione / light source

11W LED BOARD 900lm 3000K

 Dimmerabile con convertitore DALI su richiesta
Dimmable with DALI converter on request

 Utilizzo da interno
Indoor use

 Prodotto dimmerabile
Dimmable

 Tensione d'uso
Voltage

 Modulo LED integrato sostituibile
Integrated replaceable LED module

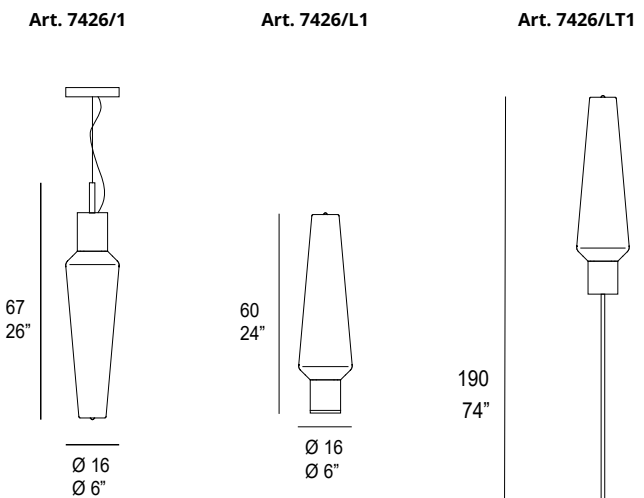
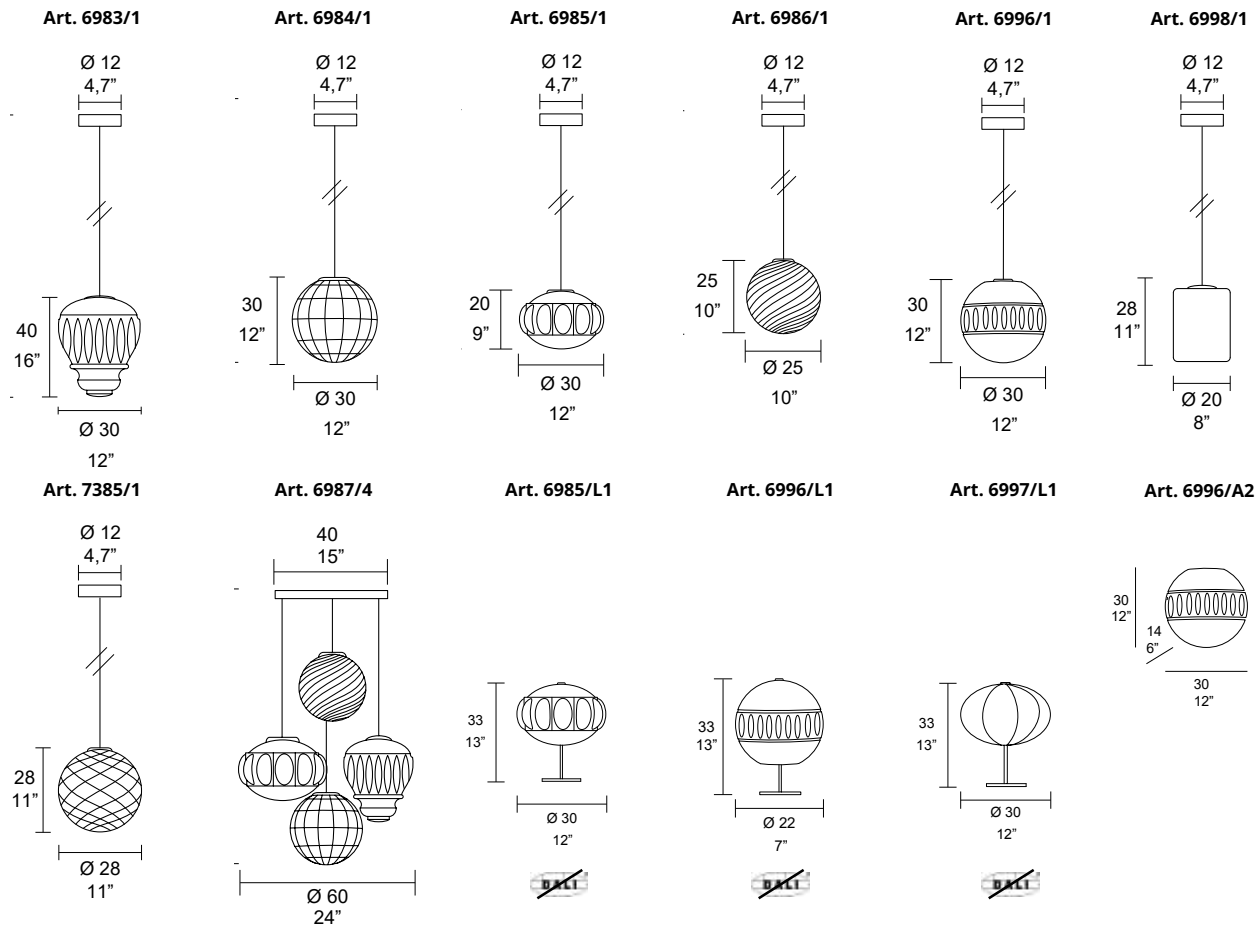
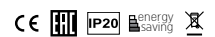

BUCCIA

Lampada in Metallo
Lamp in Metal

Struttura / Frame

V1669
foglia oro anticata
gold leaf antiqued

Diffusore / Diffuser

metallo
metal

Illuminazione / light source

LED 10W E14 LED 20W E27 5W G9



Dimmerabile con convertitore DALI su richiesta
Dimmable with DALI converter on request



Utilizzo da interno
Indoor use



Prodotto dimmerabile
Dimmable

Lampadina non compresa / Bulb not included.

Art. 5958/3

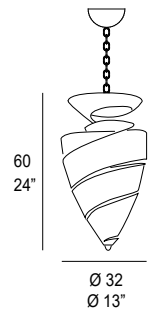

Art. 5958/1

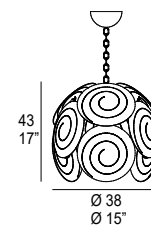

Art. 5958/P5

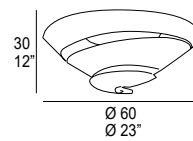

Art. 5958/P501

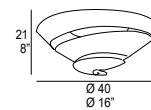

Art. 5958/A2

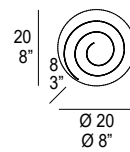

Art. 5958/L1

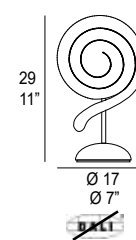

Marquise

CITY

Lampada in metallo ribruciato e ribattuto artigianalmente ed elementi in vetro colato
Metal lamp with elements handcrafted, and elements in poured glass

Struttura / Frame

V1679
foglia oro e foglia
argento anticati
gold and silver leaf
antiqued

V1669
foglia oro anticata
gold leaf antiqued

Diffusore / Diffuser

elementi in cristallo rego-
lite o piastra martellato o
ad onde
crystal elements regolite
or hammered plate or
waves

Illuminazione / light source

LED 10W E14 5W G9 LED 20W E27



Dimmerabile con convertitore DALI su richiesta
Dimmable with DALI converter on request



Utilizzo da interno
Indoor use



Prodotto dimmerabile
Dimmable

Lampadina non compresa / Bulb not included.

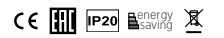

Art. 6579/42

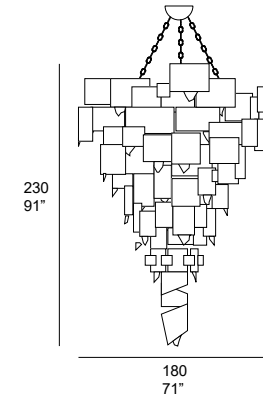

Art. 6580/28

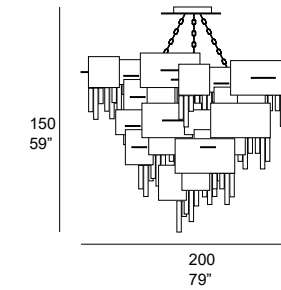

Art. 6579/4+1

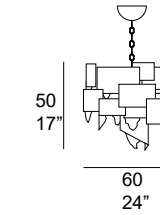

Art. 6579/A2

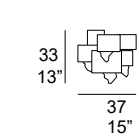

Art. 6580/6

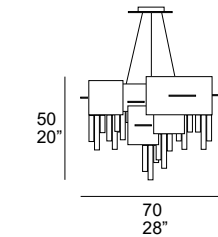

Art. 6580/A2

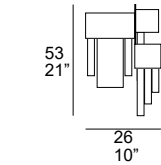

Art. 6580/4

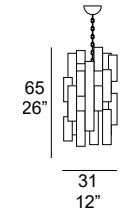

Art. 6580/A4

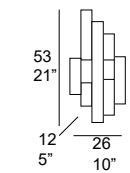

CURL

Lampada in metallo galvanico, vetro borosilicato e paralume
Galvanic metal lamp, borosilicate glass and lampshade

Struttura / Frame

V0216
Ottone lucido
Glossy brass

Diffusore / Diffuser

Paralume in tessuto
tramato color cioccolato
accoppiato a PVC
Chocolate-colored
textured fabric lam-
pshade laminated with
PVC

Illuminazione / light source

10W E14

Dimmerabile con convertitore DALI su richiesta
Dimmable with DALI converter on request

Utilizzo da interno
Indoor use

Prodotto dimmerabile
Dimmable

Lampadina non compresa / Bulb not included.



Art. 7432/5

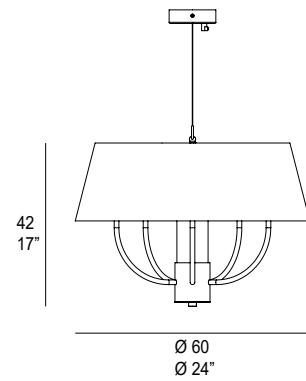

Marquise

CUSPIDE

Lampada in metallo e vetro di Murano
Lamp in metal and Murano glass lamp

Struttura / Frame

V2962
Ottone Brunito galvanico
galvanic burnished brass

Diffusore / Diffuser

Cristallo satinato inter-
no bianco
White inner satin
crystal

Illuminazione / light source

10W E14

Dimmerabile con convertitore DALI su richiesta
Dimmable with DALI converter on request

Utilizzo da interno
Indoor use

Prodotto dimmerabile
Dimmable

Lampadina non compresa / Bulb not included.



Art. 7413/5

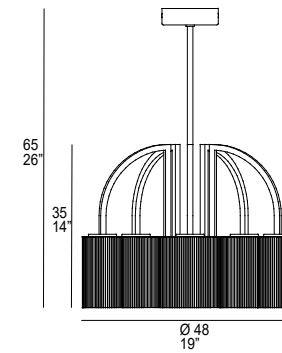

Art. 7413/A2

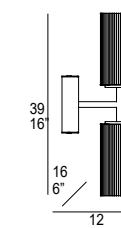

Art. 7413/A1

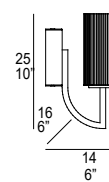

Art. 7413/L1

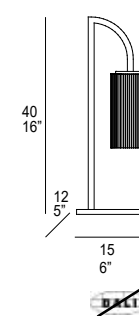

FILI

Lampada in Metallo
Lamp in Metal

Struttura / Frame

- V2950
Oro verniciato
Painted Gold
- V2721
Argento scuro
Dark silver
- V1607
Chromo lucido
Glossy chrome
- V2806
Rame lucido
Glossy copper

Diffusore / Diffuser

Illuminazione / light source



20W Gu10 Led 220/240V



Dimmerabile con convertitore DALI su richiesta
Dimmable with DALI converter on request



Utilizzo da interno
Indoor use



Prodotto dimmerabile
Dimmable

Lampadina non compresa / Bulb not included.

Marquise

FONTAINE

Lampada in metallo galvanico, dettagli in vetro e sfera in vetro di Murano sfumato con colore in pasta
Metal lamp, galvanic treatment, glass details and Murano glass sphere shaded with paste color

Struttura / Frame

- V2833
Nichel nero galvanico
Galvanic black nickel

Diffusore / Diffuser

- Vetro soffiato fumè
sfumato cristallo
Fumè shaded crystal
blown glass

Illuminazione / light source



10W E14 220/240V



Dimmerabile con convertitore DALI su richiesta
Dimmable with DALI converter on request



Utilizzo da interno
Indoor use



Prodotto dimmerabile
Dimmable

Lampadina non compresa / Bulb not included.

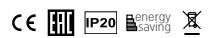

Art. D005/1 CIRCLE

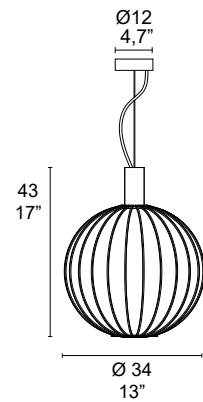

Art. D007/1 EXAGON

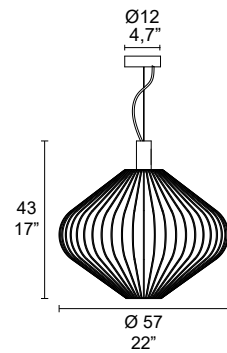

Art. D008/1 TRIANGLE

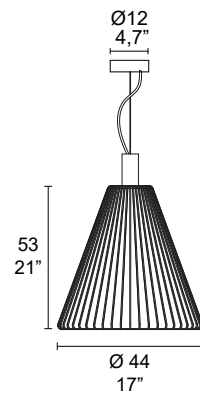

Art. D049/1 RHOMBUS

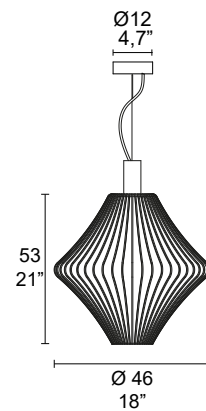

Art. 7430/6

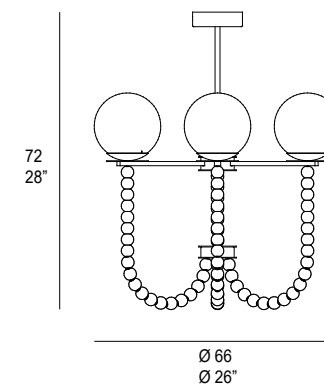

GOCCIA

Lampada in vetro Murano e metallo
Lamp in Murano Glass and metal

Struttura / Frame

- V2721
Argento scuro
Dark silver

Diffusore / Diffuser

- decorato fumè
fumè decorated
- decorato oro
gold decorated
- decorato turchese
tousquoise decorated
- decorato rosa
pink decorated

Illuminazione / light source

- LED 20W E27
- DALI Dimmerabile con convertitore DALI su richiesta
Dimmable with DALI converter on request
- Utilizzo da interno
Indoor use
- Prodotto dimmerabile
Dimmable

Lampadina non compresa / Bulb not included.

Art. 7049/1

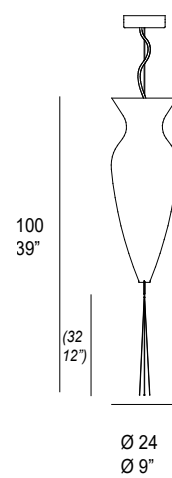

Art. 7049/3

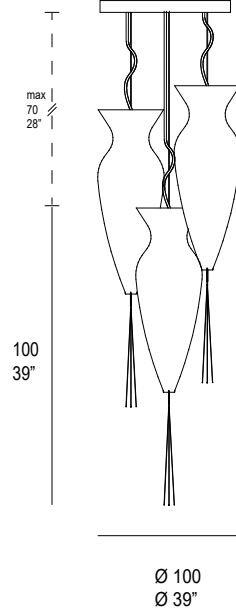

Marquise

JACK

Lampada in metallo, verniciato o trattamento galvanico e PMMA
Metal lamp, painted or galvanic treatment with and PMMA

Struttura / Frame

- V2907
Bianco opaco
Matt White
- V0216
Ottone galvanico lucido
Galvanic glossy brass
- V2805
Ottone satinato
Satin brass

Diffusore / Diffuser

- PMMA opale Ice white
Opal PMMA Ice white

Illuminazione / light source

- LED 20W E27
- DALI Dimmerabile con convertitore DALI su richiesta
Dimmable with DALI converter on request
- Utilizzo da interno
Indoor use
- Prodotto dimmerabile
Dimmable

Lampadina non compresa / Bulb not included.



Art. 7380/3

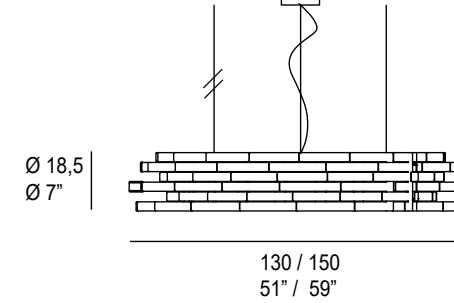

MUSEO

Lampada in metallo
Metal lamp

Struttura / Frame

V1669
foglia oro invecchiato
aged gold leaf

Diffusore / Diffuser

Illuminazione / light source

5W G9 10W E14



Dimmerabile con convertitore DALI su richiesta
Dimmable with DALI converter on request



Utilizzo da interno
Indoor use



Prodotto dimmerabile
Dimmable

Lampadina non compresa / Bulb not included.



Art. 6883/A2

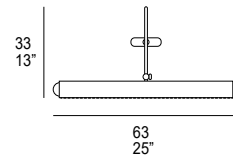

con cristalli e bordi fiammati /with crystals and flamed edges

Art. 6883/A1

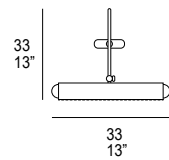

Art. 7435/A2

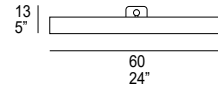

senza cristalli e bordi lisci/without crystals and straight edges

Art. 7435/A1

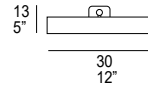

Marquise

MYA

Lampada in metallo e vetro Murano incamiciato colorato in pasta
Metal and "Incamiciato" Murano glass with coloured mixture at the origin lamp

Struttura / Frame

V2962
Brunito galvanico
Galvanic burnished

Diffusore / Diffuser

Bianco latte
Milky White
Verde incamiciato
Green "incamiciato"

Illuminazione / light source

10W E14



Dimmerabile con convertitore DALI su richiesta
Dimmable with DALI converter on request



Utilizzo da interno
Indoor use



Prodotto dimmerabile
Dimmable

Lampadina non compresa / Bulb not included.

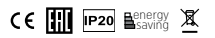

Art. 7415/1

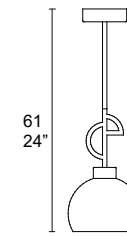

Art. 7415/3

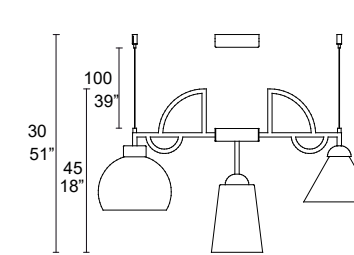

Art. 7415/8

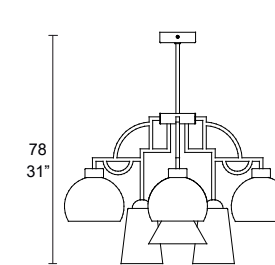

Art. 7415/16

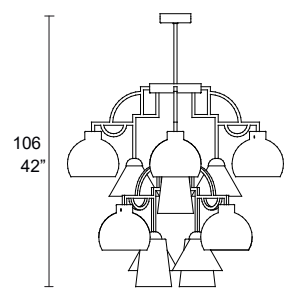

Art. 7415/A1

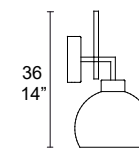

OPUS

Lampada in metallo e vetro murano soffiato
Metal lamp with Murano blown glass

Struttura / Frame

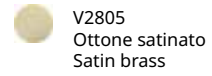

Diffusore / Diffuser

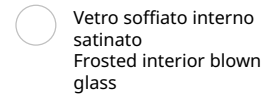

Illuminazione / light source



Dimmerabile con convertitore DALI su richiesta
Dimmable with DALI converter on request



Utilizzo da interno
Indoor use



Prodotto dimmerabile
Dimmable

Lampadina non compresa / Bulb not included.



Art. 7421/3

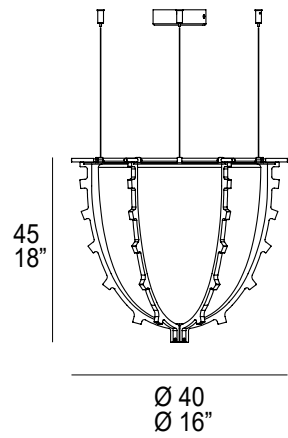

Marquise

ORION

Lampada in metallo e passamaneria, paralume in tessuto
Metal and trimming lamp, fabric lampshade

Struttura / Frame

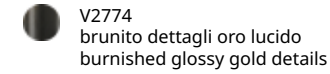

Diffusore / Diffuser

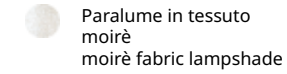

Illuminazione / light source

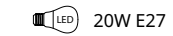

Dimmerabile con convertitore DALI su richiesta
Dimmable with DALI converter on request



Utilizzo da interno
Indoor use



Prodotto dimmerabile
Dimmable

Lampadina non compresa / Bulb not included.

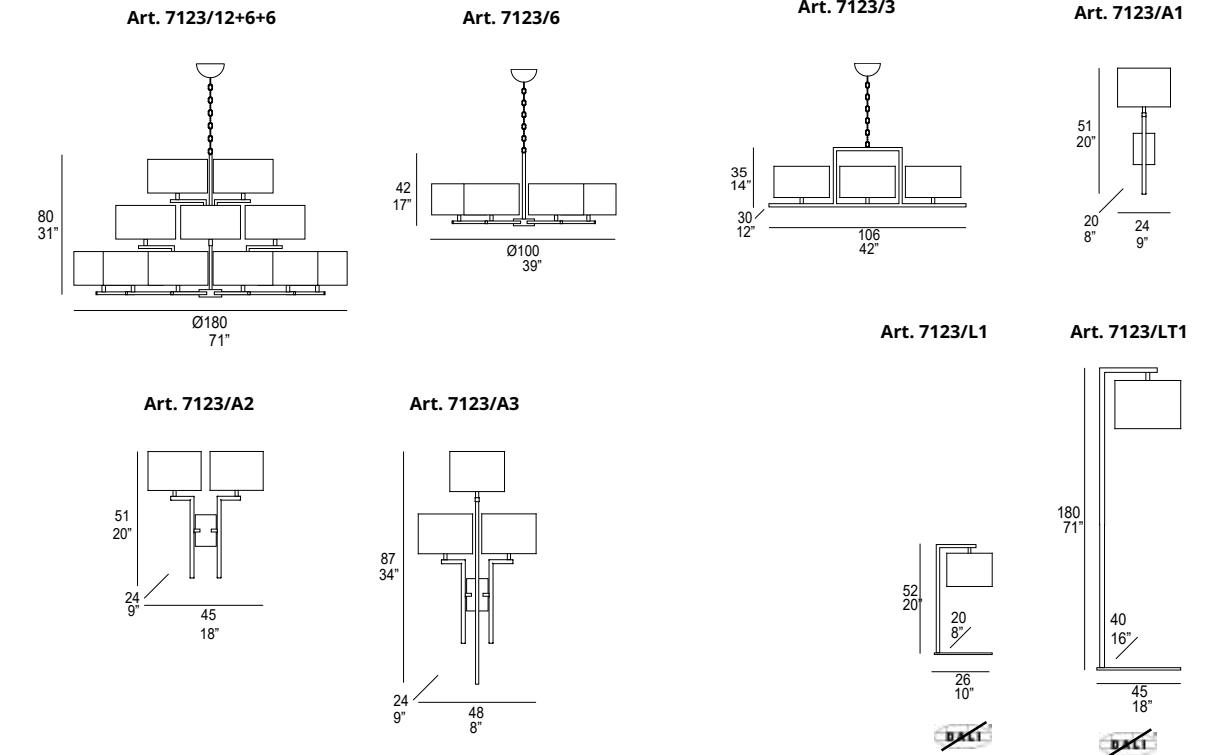
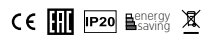

PERLA

Lampada in metallo e vetro
Metal lamp and glass

Struttura / Frame

- V2907
Bianco Opaco
Matt white
- V2962
Brunito galvanico
Galvanic burnished

Diffusore / Diffuser

- Vetro bianco
White glass
- Vetro bianco + cemento
White glass + concrete
- Vetro bianco + brunito
White glass + burnished

Illuminazione / light source

- 5W G9
 - DALI Dimmerabile con convertitore DALI su richiesta
Dimmable with DALI converter on request
 - Utilizzo da interno
Indoor use
 - Prodotto dimmerabile
Dimmable
 - 24 Tensione d'uso
Voltage
 - Modulo LED integrato sostituibile
Integrated replaceable LED module
- CE ENEC IP20 Energy saving

Art. 7387/A1

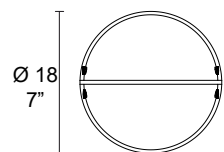

Marquise

PETAL

Lampada in metallo
Metal lamp

Struttura / Frame

- V2901
Ferro decapato + Acciaio anticato
Pickled iron + Antiqued steel
- V2903
Ottone brunito + oro anticato
Burnished brass + antiqued gold

Diffusore / Diffuser

- PMMA

Illuminazione / light source

- STRIP LED 20W 3000K 1410lm 110/240V
LED STAR 1W 3000K 120lm 110/240V
 - DALI Dimmerabile con convertitore DALI su richiesta
Dimmable with DALI converter on request
 - Utilizzo da interno
Indoor use
 - Prodotto dimmerabile
Dimmable
 - 24 Tensione d'uso
Voltage
 - Modulo LED integrato sostituibile
Integrated replaceable LED module
- CE ENEC IP20 Energy saving

Art. 7377/A1 S

Art. 7377/A1 L

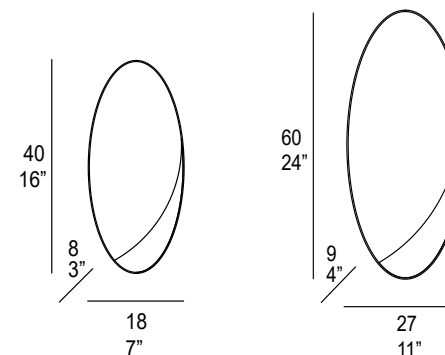

Le finiture di questa collezione sono di natura artigianale, rifinite a mano; prevedono variazioni e naturali imperfezioni nel risultato finale. Non potranno esistere perciò due prodotti identici.

The finishes in this collection are handcrafted, they involve variations and natural imperfections in the final result. Therefore, there cannot be two identical products.

PILL

Lampada in metallo galvanico 24K e vetro Murano
Metal lamp galvanic treatment 24k and Murano glass

Struttura / Frame



V0197
Oro 24K / Gold 24K
vetro bianco in pasta
soffiato in gabbia
cage-blown white paste
glass

Diffusore / Diffuser



Fumé decorato
Fumé decorated



Ambra decorato
Amber decorated

Illuminazione / light source



20W E27



5W G9



Dimmerabile con convertitore DALI su richiesta
Dimmable with DALI converter on request



Utilizzo da interno
Indoor use



Prodotto dimmerabile
Dimmable

Lampadina non compresa / Bulb not included.



Art. 7237/1

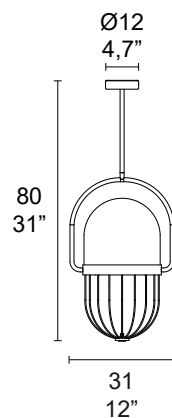

Art. 7237/A1

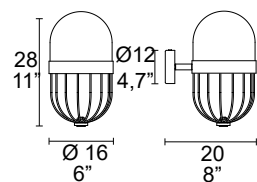

Art. 7237/L1

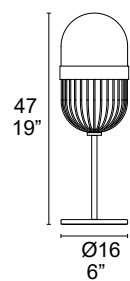

Art. 7237/LT1

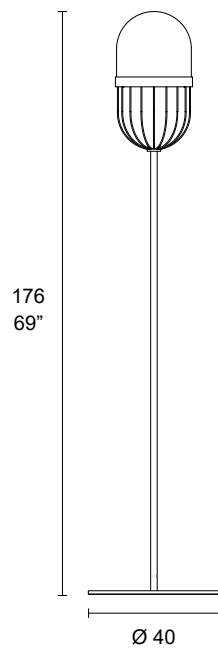

Marquise

RAYS

Lampada in metallo, verniciato o trattamento galvanico, e vetro murano balloton
Metal lamp, painted or galvanic treatment, and murano balloton glass

Struttura / Frame



V0199
Nero opaco
Matt black



V2805
Ottone satinato
Satin brass

Diffusore / Diffuser



Cristallo balloton
Crystal balloton

Illuminazione / light source



10W E14



Dimmerabile con convertitore DALI su richiesta
Dimmable with DALI converter on request



Utilizzo da interno
Indoor use



Prodotto dimmerabile
Dimmable

Lampadina non compresa / Bulb not included.



Art. 7209/3

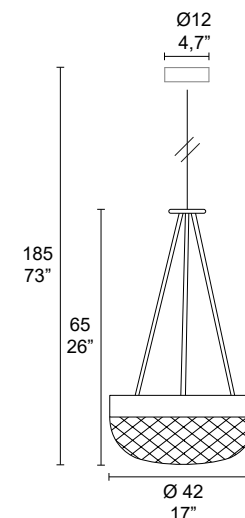

Art. 7209/P3

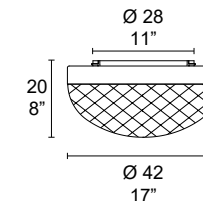

Art. 7209/L3

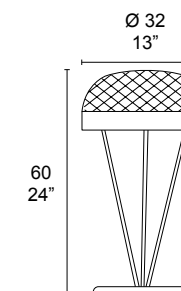

SASS

Lampada in metallo verniciato
Painted metal lamp

Struttura / Frame

Diffusore / Diffuser

V2738
Foglia oro e foglia argento
Gold and silver leaf

V2907
Bianco opaco
Matt white

Illuminazione / light source

LEAD BOARD 4,5W 1368lm 3000K 110/240V
G9 su richiesta / G9 on request

 Dimmerabile con convertitore DALI su richiesta
Dimmable with DALI converter on request

 Utilizzo da interno
Indoor use

 Prodotto dimmerabile
Dimmable

 Tensione d'uso
Voltage

 Modulo LED integrato sostituibile
Integrated replaceable LED module

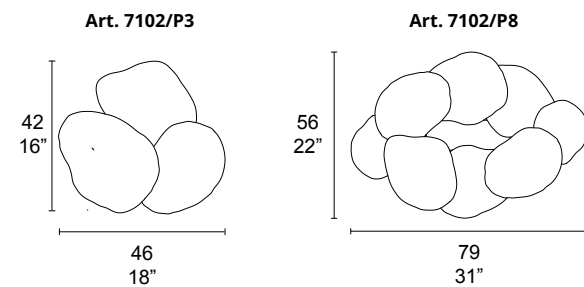

Marquise

SKY

Lampada in metallo verniciato
Painted metal lamp

Struttura / Frame



Diffusore / Diffuser

Illuminazione / light source

V1679
Foglia oro e foglia argento anticati
Gold and silver leaf antiqued

V1669
Foglia oro anticata
Gold leaf antiqued

V2907
Bianco opaco
Matt white

 20W E27  10W E14  5W G9

 Dimmerabile con convertitore DALI su richiesta
Dimmable with DALI converter on request

 Utilizzo da interno
Indoor use

 Prodotto dimmerabile
Dimmable

Lampadina non compresa / Bulb not included.

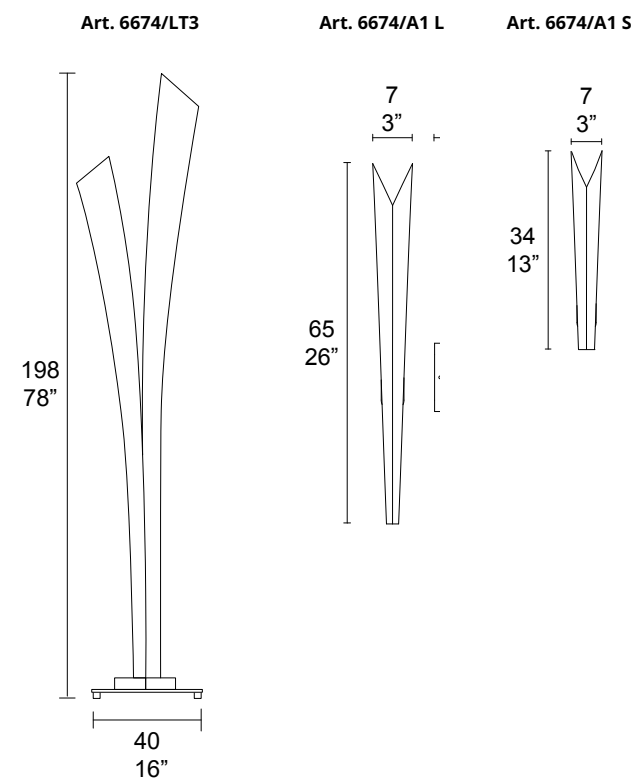

TUMBLER

Lampada in metallo e marmo con vetro inciso
Metal and marble lamp with engraved glass

Struttura / Frame

V2972
Nero opaco ed oro galvanico
Black matt and galvanic gold

Diffusore / Diffuser

Vetro con incisioni a mano
Handmade engraved, glass

Illuminazione / light source

LED 20W E27 LED 15W E14

 Dimmerabile con convertitore DALI su richiesta
Dimmable with DALI converter on request

 Utilizzo da interno
Indoor use

 Prodotto dimmerabile
Dimmable

Lampadina non compresa / Bulb not included.



Art. 7434/1S Art. 7434/1L

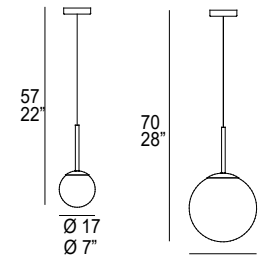

Art. 7434/2

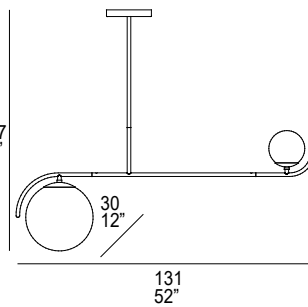

Art. 7434/A2 Art. 7434/L1S Art. 7434/L1L Art. 7434/LT1

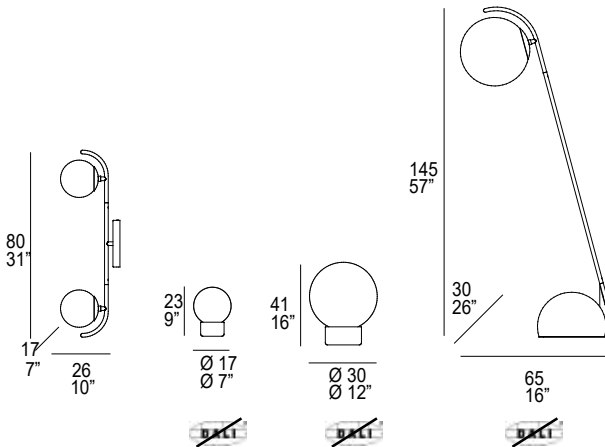

Marquise

Certifications



Prodotto conforme ai requisiti essenziali per la commercializzazione ed utilizzo nell'Unione Europea.
Product in compliance with the essential requirements for the marketing and use in the European Union.



Prodotto conforme a tutte le normative tecniche delle procedure di valutazione dell'Unione doganale eurasiatica.
Product complies with all technical regulations of the Eurasian Customs Union evaluation procedures.



Utilizzo da interno
Indoor use



Utilizzo da esterno
Outdoor use



Prodotto dimmerabile
Dimmable



Lampadina non dimmerabile
Non-Dimmable Bulb



Tensione d'uso
Voltage



Tensione d'uso
Voltage



Lampadina a LED sostituibile
Replaceable LED bulb



Non protetto contro l'ingresso di liquidi
Not protected against liquids permeation



Modulo LED integrato non sostituibile
Integrated non-replaceable LED module



Modulo LED integrato sostituibile
Integrated replaceable LED module



Da installare con foro per incasso
Recessed installation







Prodotto orientabile
Swiveling Product



Peso netto
Net weight



Peso lordo
Gross weight

Type	Lampadine led / Led bulbs	Watt
E14		10W
E27		20W
G9		5W
Gx53		8W
GU 10		15W



Lampadina dimmerabile. La compatibilità con i sistemi di dimmerazione è indicata nelle specifiche di ogni prodotto.
Dimmable bulb. Compatibility with dimming systems is indicated in the specs of each product.



Lampadina non dimmerabile - Not Dimmable

VISUAL DIRECTION AND STYLING

GIORGIO BISCARO
M.M. LAMPADARI

**SET DESIGN & STYLING
3D VISUALISATION**

M.M. LAMPADARI
LAURA POZZI
MARILENA FRAGKOU
STUDIO ROCCI
BRUGER STUDIO

PHOTOGRAPHY

ASOLANAGROUP
ANTONIO CAMPANELLA
ALESSANDRO DI BON
FEDERICO MARIN
STUDIO ROCCI
EMANUELE SURIAN
STUDIO STEP

COLOUR CALIBRATION

GM STUDIO1

THANKS TO

AGAPE
KREOO
MARAZZI GROUP
MINIFORMS
MOLTENI & C
MOROSO
NODUS RUG
SCAPIN
SCULPTURE JEUX
SONIA PEDRAZZINI

THANKS TO

ALTACORTE PG 85
MOTIFA DESIGN AND
GABORTASIPHOTO PG 145 - 147
LIGHTS LIGHTS LIGHTS PG 140
ANC INTERIORS PG 118

Tutti i prodotti MM Lampadari S.r.l. sono conformi alle direttive Europee in vigore.

Ogni articolo prodotto presentato nel catalogo é realizzato e decorato artigianalmente, pertanto lievi differenze nelle dimensioni, nel colore o nei dettagli costituiranno il carattere di unicità proprio della lavorazione manuale.

All MM Lampadari S.r.l. Products comply with the European directives in force.

Each product presented in the catalogue is produced and decorated by hand; therefore, slight colour, size or detail differences will make the unique character in the handwork.

MM Lampadari S.r.l. si riserva il diritto di intervenire in qualunque momento e senza preavviso per apportare le modifiche che ritenesse più opportune per migliorare il prodotto o in risposta a qualsiasi esigenza di carattere normativo costruttivo o commerciale.

MM Lampadari S.r.l. reserves its right to intervene in every moment and without forewarning in order to make the modifications more suitable to improve the product or reply to each legal, manufacturing or commercial requirement.



© M.M. LAMPADARI. È vietata la riproduzione anche parziale di questo catalogo

© M.M. LAMPADARI. It is forbidden to reproduce any part of this catalogue

Riedizione Aprile 2025
Reissue April 2025



mmlampadari

Via Feltrina 37 , 31040 Pederobba (TV) Italy

Email: mmlampadari@mmlampadari.com Web: www.mmlampadari.com Tel. +39 0423 688800



mmlampadari