



2025



**mm**lampadari



# META- MMM

PER LA NUOVA EDIZIONE DEL NOSTRO CATALOGO ABBIAMO PENSATO FOSSE ORMAI DIVENTATO LIMITANTE PENSARE A DUE SOLE COLLEZIONI INTESTANDOLE A UN TEMA CLASSICO E A UN TEMA DESIGN: LE SFUMATURE PROGETTUALI SONO INFINITE, E LA NOSTRA ATTENZIONE AL PRODOTTO CI HA PORTATO A RICONSIDERARE LA STESSA SEMANTICA DELLE COLLEZIONI PER CONDENSARLE IN VISIONI, PIÙ CHE AGGETTIVI, E TRASFERIRE QUINDI ALL'OSSERVATORE UN'ESPERIENZA DI PRODOTTO, ANZICHÉ APPROSSIMARLA IN UN ATTRIBUTO. IL CATALOGO CHE STATE SFOGLIANDO È FRUTTO DI UNA METICOLOSA REVISIONE DI QUANTO MM HA CREATO NEGLI ANNI, OPERATA PENSANDO ALL'HABITAT, ALLA PERSONALITÀ E ALLO STILE DI VITA CHE ABBIAMO IMMAGINATO CARATTERIZZARE I NOSTRI CLIENTI.

SI PARLA SPESSO DI DNA AZIENDALE, MA ALTRETTANTO SOVENTE SI DIMENTICA CHE IN TERMINI BIOLOGICI IL DNA È SOGGETTO A UNA CONTINUA MUTAZIONE, UN TENTATIVO DELLA NATURA DI PROVARE STRADE NUOVE E MAI PERCORSE: IL CATALOGO M.MM È ESATTAMENTE UNA MUTAZIONE DI STANDARD, UNA IMPROVVISAZIONE SU UN TEMA CHE L'ORCHESTRA CONOSCE MOLTO BENE, MA CHE MERITA CONTINUA SPECULAZIONE, ANALISI, RINCORSA. IN QUESTA COLLEZIONE DESIDERIAMO MOSTRARVI DOVE CI HA PORTATO LA NOSTRA RICERCA.

FOR THE NEW EDITION OF OUR CATALOG WE THOUGHT IT HAD NOW BECOME LIMITING TO THINK OF JUST TWO COLLECTIONS, NAMING THEM WITH A CLASSIC THEME AND A DESIGN THEME: THE DESIGN NUANCES ARE INFINITE, AND OUR ATTENTION TO THE PRODUCT HAS LED US TO RECONSIDER THE VERY SEMANTICS OF THE COLLECTIONS TO CONDENSE THEM INTO VISIONS, RATHER THAN ADJECTIVES, AND THEREFORE TRANSFER A PRODUCT EXPERIENCE TO THE OBSERVER, RATHER THAN APPROXIMATING IT IN AN ATTRIBUTE. THE CATALOG YOU ARE BROWSING IS THE RESULT OF A METICULOUS REVIEW OF WHAT MM HAS CREATED OVER THE YEARS, CARRIED OUT THINKING ABOUT THE HABITAT, PERSONALITY AND LIFESTYLE THAT WE IMAGINED CHARACTERIZING OUR CUSTOMERS.

WE OFTEN TALK ABOUT CORPORATE DNA, BUT EQUALLY OFTEN WE FORGET THAT IN BIOLOGICAL TERMS DNA IS SUBJECT TO CONTINUOUS MUTATION, AN ATTEMPT BY NATURE TO TRY NEW AND NEVER-TRODDEN PATHS: THE M.MM CATALOG IS EXACTLY A MUTATION OF STANDARDS, A IMPROVISATION ON A THEME THAT THE ORCHESTRA KNOWS VERY WELL, BUT WHICH DESERVES CONTINUOUS SPECULATION, ANALYSIS AND PURSUIT. IN THIS COLLECTION WE WANT TO SHOW YOU WHERE OUR RESEARCH HAS TAKEN US.

# DA OLTRE 50 ANNI INTERPRETIAMO LA MATERIA PER CREARE OPERE DI LUCE

MM LAMPADARI NASCE NEL 1966, MEZZO SECOLO CHE CI HA VISTI CRESCERE E DIVENTARE UNA TRA LE PIÙ IMPORTANTI REALTÀ ITALIANE NEL SETTORE DELL'ILLUMINAZIONE D'INTERNI A LIVELLO INTERNAZIONALE. QUELLO CHE CI CONTRADDISTINGUE È LA GRANDE ABILITÀ DI PLASMARE LA MATERIA SECONDO LE TRADIZIONALI TECNICHE DI LAVORAZIONE DEL FERRO, CHE ANCORA OGGI VIENE BATTUTO A MANO DA ESPERTI ARTIGIANI.

LO STILE MM LAMPADARI È UNO STILE BEN DEFINITO, IL NOSTRO È UN LAVORO FATTO CON PASSIONE CHE CREA VERE E PROPRIE OPERE D'ARTE ARTIGIANA PER ILLUMINARE OGNI AMBIENTE CON GUSTO E UNICITÀ. SIAMO STILISTI DELL'ILLUMINAZIONE, CAPACI DI FONDERE IN UN'UNICA CREAZIONE IL METALLO E IL VETRO DI MURANO. SIAMO CUSTODI DI UN SAPERE ANTICO MA SAPPIAMO GUARDARE ANCHE AL FUTURO PROPONENDO PEZZI STORICI IN CHIAVE MODERNA E REALIZZAZIONI DAL GUSTO PURAMENTE CONTEMPORANEO.



# WE'VE BEEN SHAPING RAW MATERIALS TO CREATE LIGHT ARTWORKS FOR MORE THAN 50YRS

MM LAMPADARI WAS FOUNDED IN 1966, AND FOR MORE THAN HALF A CENTURY WE HAVE BEEN GROWING AND EXPANDING OURSELVES, BECOMING ONE OF THE MOST IMPORTANT REALITY OF THE ITALIAN LIGHTING FIELD ON AN INTERNATIONAL LEVEL. OUR GREAT ABILITY TO SHAPE IRON THROUGH TRADITIONAL TECHNIQUES AND THE WORK OF EXPERTS IS WHAT MAKES STAND US OUT. MM LAMPADARI WELL-DEFINED STYLE AND THE PASSION WE PUT INTO OUR CREATIONS ARE THE THINGS THAT MAKE US CREATE HANDCRAFTED MASTERPIECES.

WE ARE LIGHTING DESIGNERS, ABLE TO MELT TOGETHER METAL AND MURANO GLASS.

OUR AIM IS THE ONE OF ILLUMINATING EVERY SPACE WITH STYLE AND DISTINCTIVENESS, LEARNING FROM OUR PAST TRADITIONS BUT ALWAYS LOOKING AT THE FUTURE, OFFERING PAST DESIGNS THROUGH MODERN SHAPES AND CONTEMPORARY REALIZATIONS.

# INDEX



TRIGON 12



LOOP 16



MYA POP 20



TILTLIT 24



CHOOPS 28



ARCH 34



CLESSIDRA 46



CODE 52



DOTS 58



PAPILLON 66



ARIA 74



MOONLIGHT 86



BELLA TUBE 88



RIPPLE 94



BALLOON 100



BALLOTON 106



CHILL 112



LAYLA 120



LEAF 126



MAESTRO 134



MATA 140



MILA 146



PINEAPPLE 152



RAIN 158



WHALE 164



KINGDOM 170



PARAMOUNT 176



# TRIGON

DESIGNED BY MM LAMPADARI WORKSHOP



# TRIGON

Le curve della superficie  
vetrosa sembrano suggerire  
di accarezzarla, percepirne le  
sinuosità, ascoltare il rumore  
prodotto dalla pelle contro  
le pareti, impercettibilmente  
ruvide per massimizzare  
la dispersione della luce e  
creare un morbido effetto  
luminoso.

*The curves of the glassy  
surface seem to suggest  
caressing it, perceiving  
its sinuosities, listening  
to the noise produced by  
the skin against the walls,  
impercetibly rough to  
maximize the dispersion  
of light and create a soft  
luminous effect.*



# LOOP

DESIGNED BY MM LAMPADARI WORKSHOP



# LOOP

La contrapposizione tra la densa trasparenza del vetro soffiato e l'opaca solidità della lama metallica che lo scherma è la caratteristica più evidente di questa lampada a montaggio su superficie, capace di illuminare delicatamente ma con adeguatezza lo spazio che la circonda.

*The contrast between the dense transparency of the blown glass and the opaque solidity of the metal blade that shields it is the most evident feature of this surface-mounted lamp, capable of delicately but adequately illuminating the space that surrounds it.*



# MYA POP

DESIGNED BY LENZIA MONDIN



# MYA POP

Lampada a sospensione con struttura metallica e diffusori multipli in vetro. La grande articolazione del telaio compone una geometria complessa e radicale, sulla quale si innestano i corpi illuminanti in vetro decorato. Chiaro rimando alle sfarzose strutture architettoniche d'epoca Art Deco, il lampadario allude facilmente anche a stilemi precolombiani, rimarcati dalle evidenti spigolosità delle strutture metalliche.

*Suspension lamp with metal structure and multiple glass diffusers. With its complex and radical geometric design, the pendant lamp Mya makes for a sublime addition to contemporary decors (with a retro twist). Inspired by Art Deco, it also alludes to pre-Columbian stylistic elements as the sharp-edged metal structure underlines.*



# TILT LIT

DESIGNED BY GIORGIO BISCARO

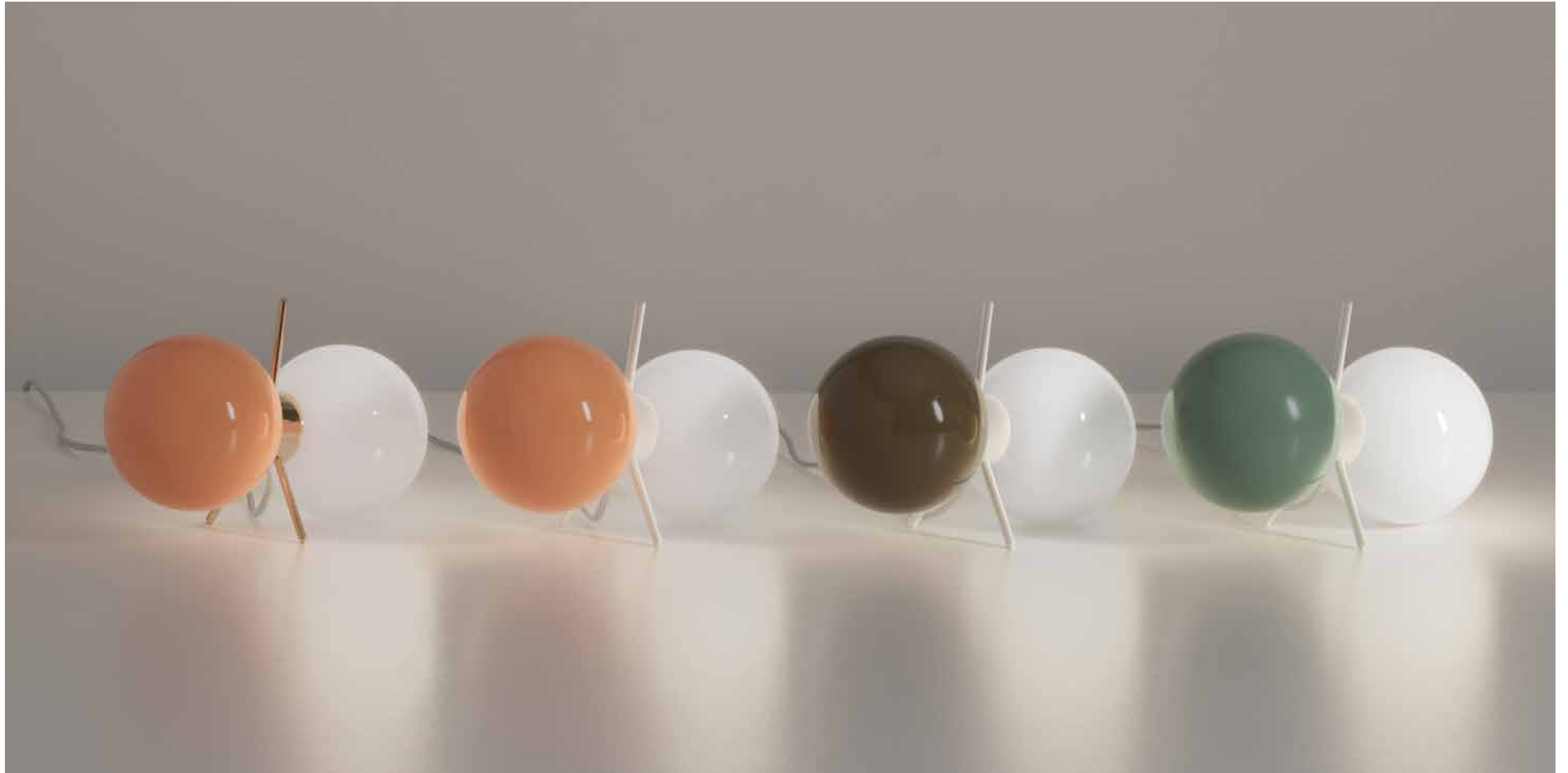

# TILTIT

Piccola e preziosa lampada da tavolo disegnata da Giorgio Biscaro, gioca sull'apparente instabilità di due sfere in vetro, in costante equilibrio sulla struttura metallica che le connette e che permette all'utilizzatore di poter rivolgere alternativamente uno dei due globi verso l'alto o il basso per modulare delicatamente l'emissione luminosa.

*This small and precious table lamp designed by Giorgio Biscaro plays on the apparent instability of two glass spheres, in constant balance on the metal structure that connects them and which allows one of the two globes to be alternately turned up or down to delicately modulate the light output.*



# CHOOPS

DESIGNED BY GIORGIO BISCARO

PRODUCT  
RELEASE 2025



PRODUCT  
RELEASE 2025

# CHOOPS

La perfezione del metallo tornito, enfatizzata dalla finitura liscia e lucente, abbinata alla cristallina trasparenza del vetro prismatico rendono Choops un solido elemento visivo, perfetto nella forma e nella coniugazione dei volumi. Richiamo affettuoso al design Space Age degli anni '70, lo reinterpreta in chiave squisitamente contemporanea.

*The perfection of spun metal, emphasized by the smooth and shiny finish, combined with the crystalline transparency of the prismatic glass make Choops a solid visual element, perfect in its shape and in the combination of its volumes. An affectionate reference to the Space Age design of the 70s, it provides a new, contemporary take on it.*

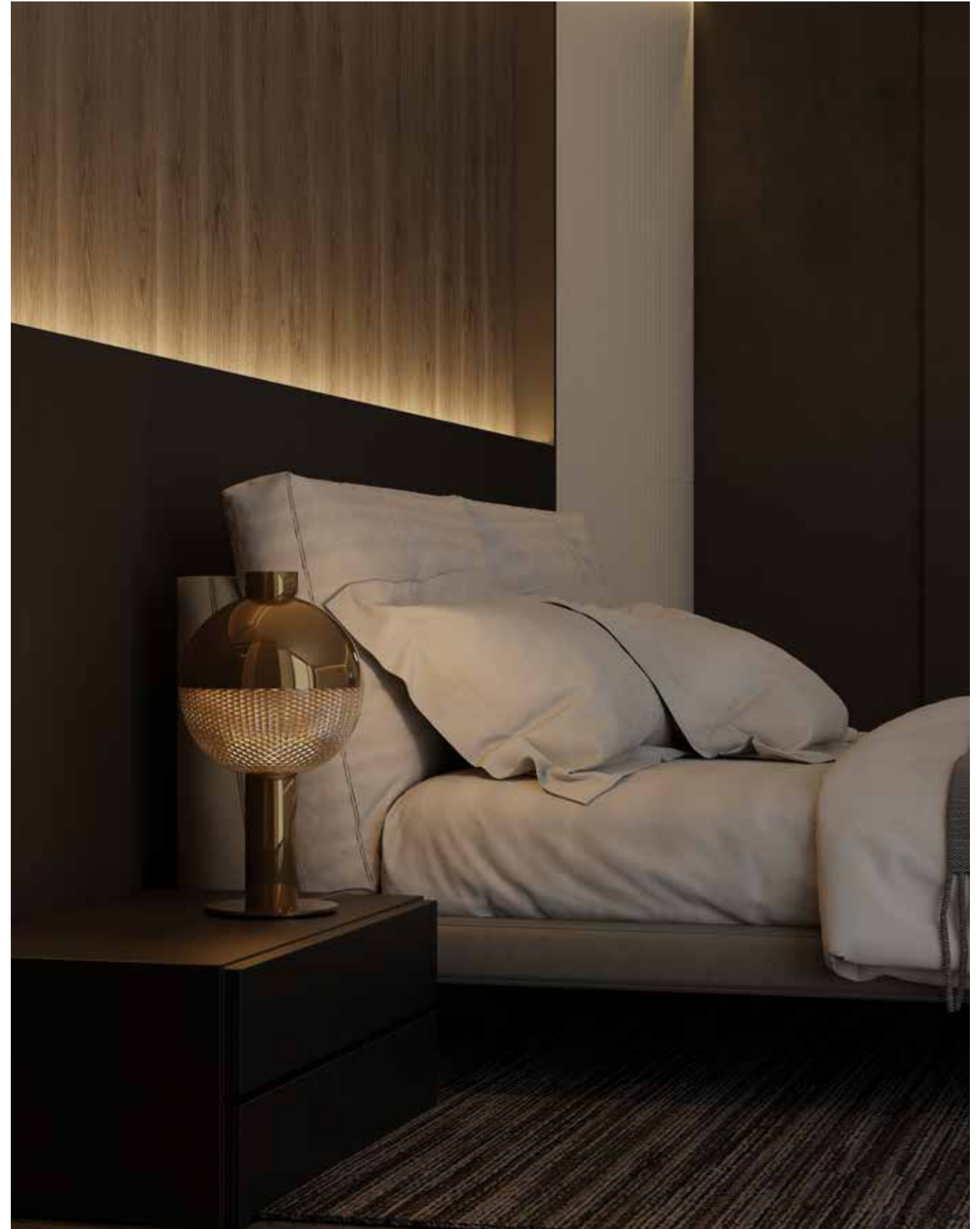

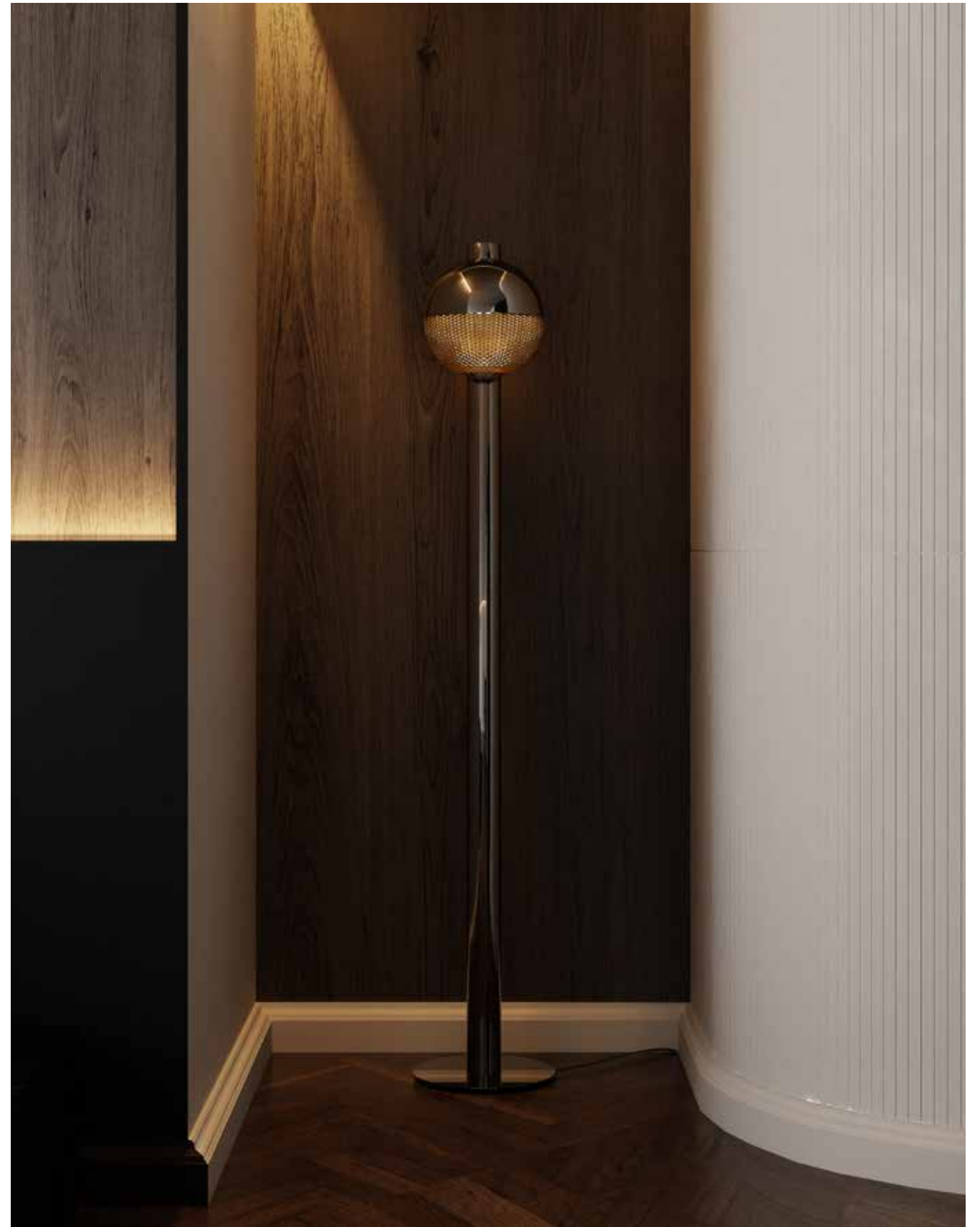

# ARCH

DESIGNED BY MATTEO VALENTI



# ARCH

Una serie dalle linee essenziali, pulite e slanciate. Un'eleganza anni 70 che si esprime nei dettagli: snelli tubi metallici leggermente ricurvi e sfere in vetro bianco opalino. Da semplici elementi singoli arrivano ad intrecciarsi per creare volumi in perfetto equilibrio. Per la sua conformazione si presta inoltre, per progetti speciali, ad una notevole personalizzazione.

*A series with essential, clean and slender lines. A 70's elegance that is expressed in the details: slender slightly curved metal tubes and spheres in white opaline glass. From simple single elements, they can be intertwined to create perfectly balanced volumes. Due to its shape, it is also suitable, for special projects, for a considerable customization.*









# CLESSIDRA

DESIGNED BY MATTEO ZORZENONI



# CLESSIDRA

Clessidra è un progetto di lampade modulari caratterizzate da forme pure e eleganti: una ciotola rivolta verso l'alto e una verso il basso connesse da un semplice tubo, entrambi illuminanti, permettono una perfetta illuminazione. Possono essere utilizzate singolarmente oppure con struttura a ragno che permette di creare un'infinita varietà di composizioni. Struttura in metallo, illuminazione led.

*Clessidra is a project of modular lamps characterised by pure and elegant shapes: a bowl facing upwards and one downwards connected by a simple tube, both illuminating, allow perfect lighting. They can be used individually or with a spider structure that allows you to create an infinite variety of compositions. Metal structure led lighting.*







# CODE

DESIGNED BY MM LAMPADARI WORKSHOP



# CODE

Un assieme di semplici elementi dà vita a questa lampada. Due linee luminose per illuminare l'ambiente in maniera bidirezionale e che possono essere accese in maniera indipendente. Cover facili da montare e colori di impatto che lasciano il segno. Viene proposta nelle finiture grezze dell'ottone acidato e ferro decapato oppure con il rivestimento in pelle nera per un effetto più elegante.

*A combination of simple elements gives life to this lamp. Two light lines to illuminate the room bidirectionally and which can be switched on independently. Easy-to-fit covers and striking colours that leave their mark. It is available in the raw finishes of acid-etched brass and pickled iron or with black leather upholstery for a more elegant effect.*

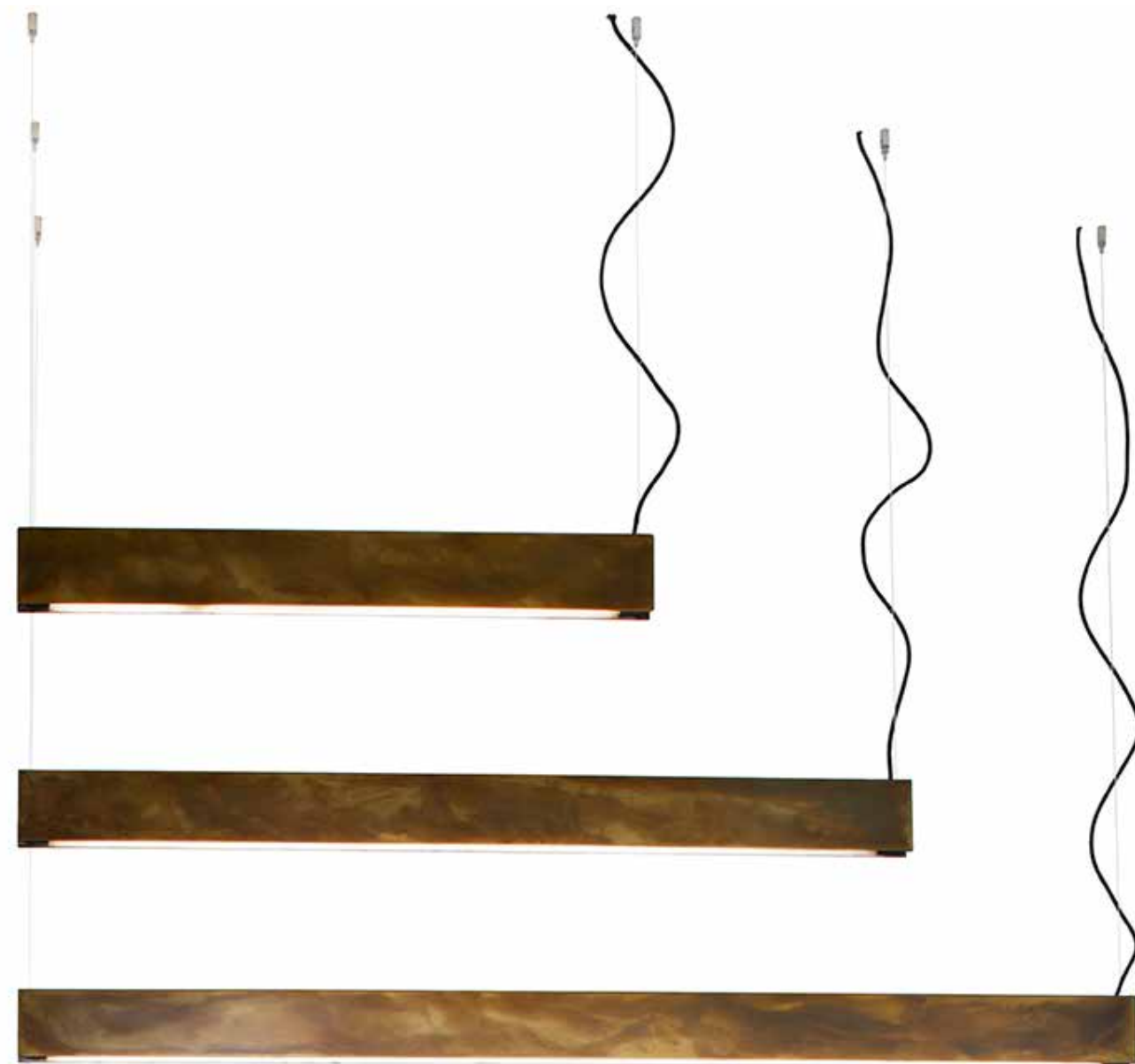

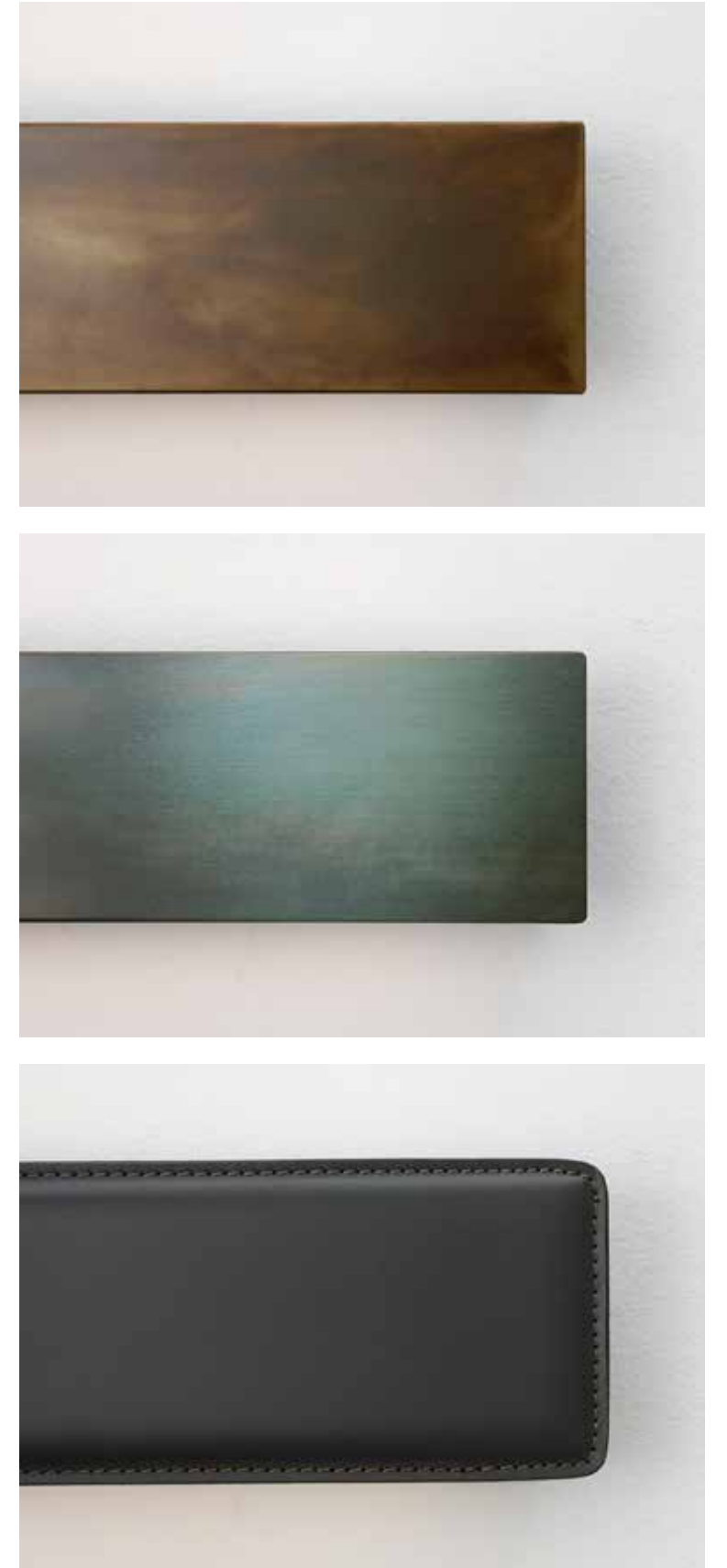

# DOTS

DESIGNED BY MATTEO ZORZENONI



# DOTS

Dots è la nuova reinterpretazione di un prodotto Classico di Maison MM, sottoposto ad una ricerca di semplicità tesa ad eliminare ogni elemento non necessario. Ciò che ne rimane è "l'anima" della struttura in metallo di cui sono stati fatti risaltare gli snodi di contatto. A sottolinearne le linee arrotondate e delle sfere in vetro bianco opalino.

*Dots is the new reinterpretation of a Classic product by Maison MM, subjected to a search for simplicity aimed at eliminating any unnecessary element. What remains is the "soul" of the metal structure of which the contact joints have been highlighted. To underline the rounded lines and spheres in white opal glass.*



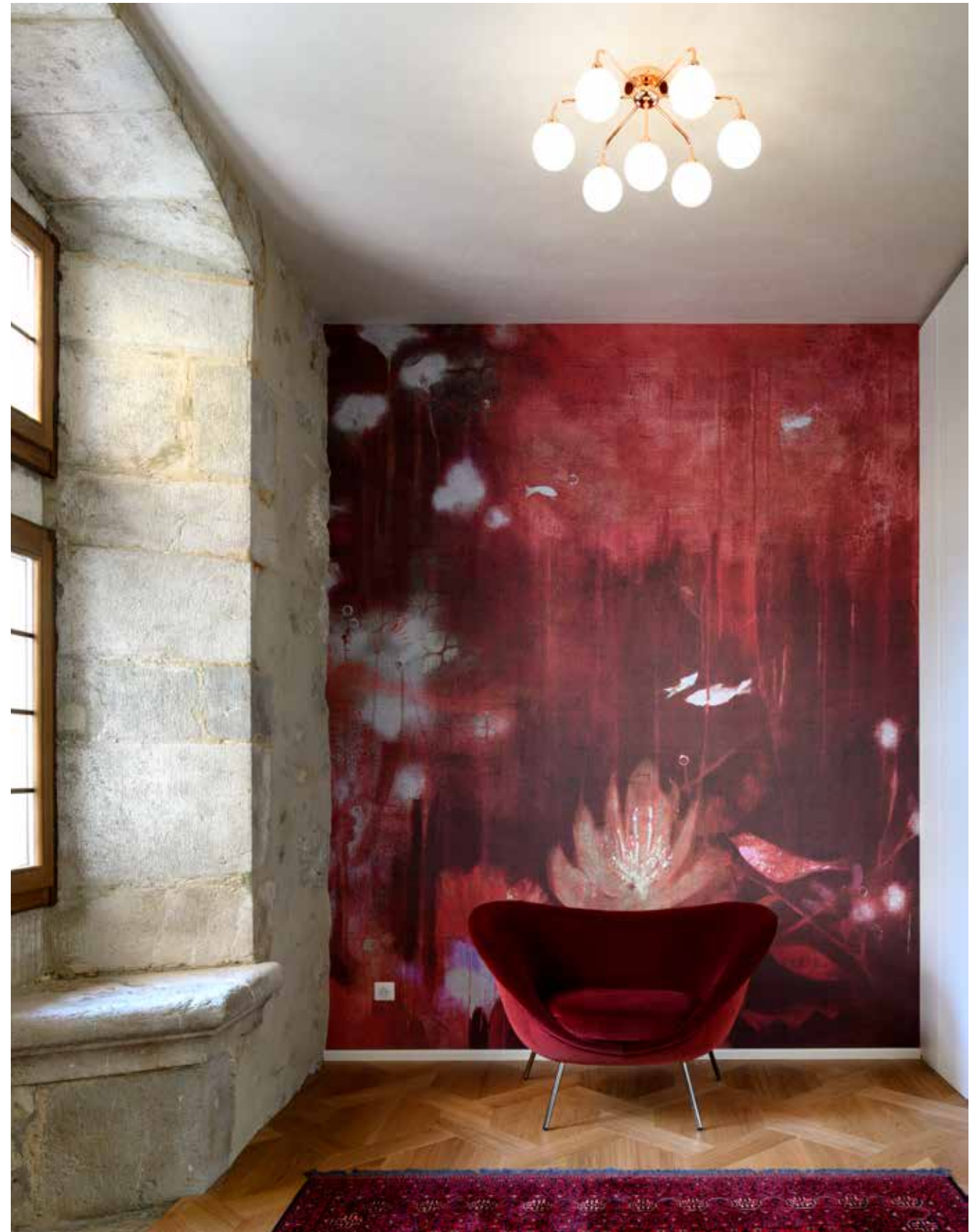



# PAPILLON

DESIGNED BY MATTEO ZORZENONI



# PAPILLON

Le forme fluide dei tubi metallici lavorati ad arte di questo "chandelier" vogliono ricordare il papillon, accessorio dell'abbigliamento classico. Come il simbolo di eleganza ed icona di stile sin dalla fine del XIX secolo queste lampade arredano e completano l'immagine dell'ambiente in cui sono inserite donandole un tocco di ricercatezza.

*The fluid shapes of the metal tubes worked to art of this "chandelier"; want to remember the bow tie, accessory of the classic clothing. As the symbol of elegance and style icon since the end of the 19th century, these lamps furnish and complete the image of the environment in which they are placed, giving it a touch of sophistication.*



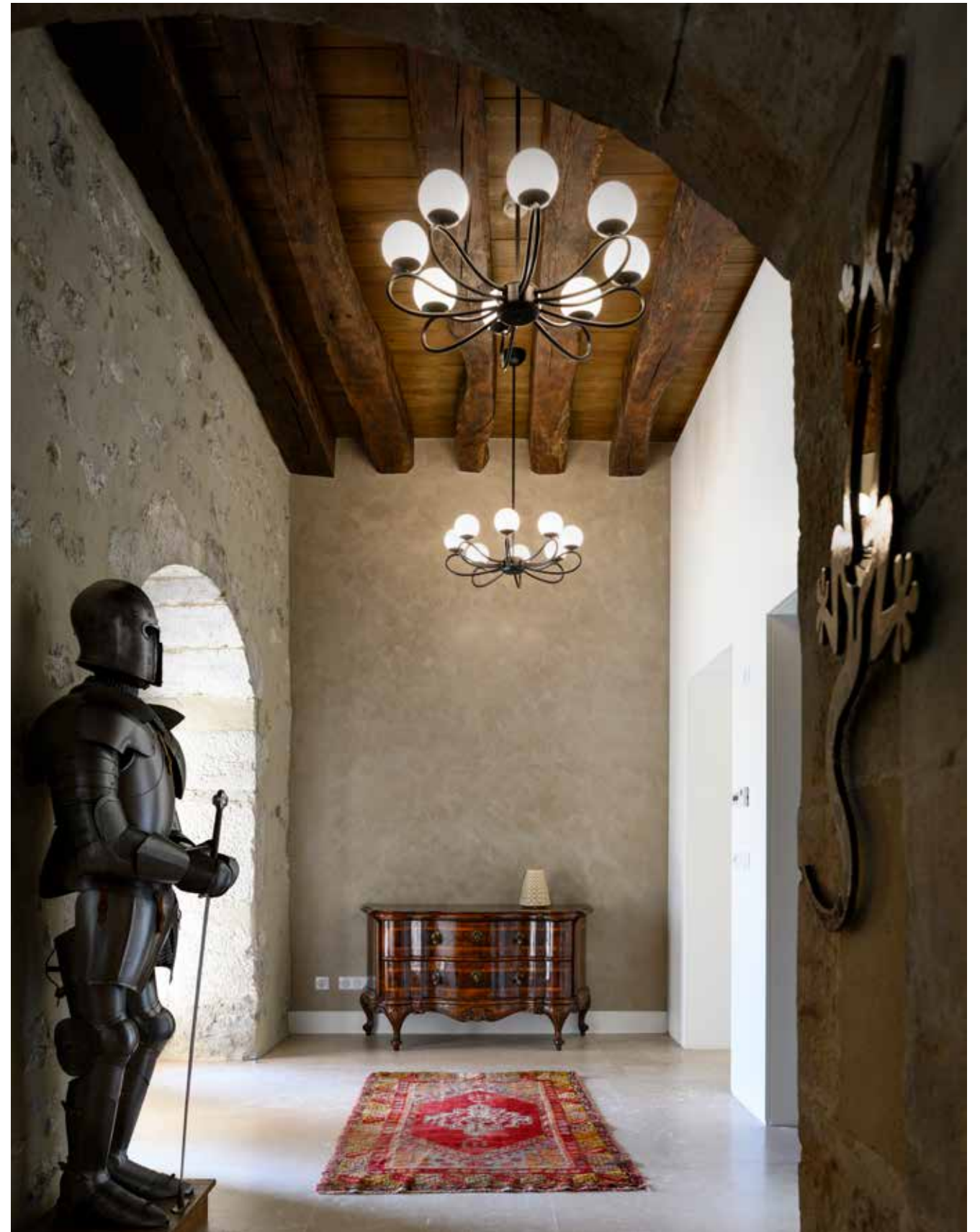



# ARIA

DESIGNED BY ROBERTO FAVARETTO



# ARIA

Da sempre il confronto con il concetto di vuoto, ambiguo da rappresentare, è frutto di un continuo dibattito, proprio per il senso della sua esistenza e le leggi che lo governano.

Aria con le sue linee essenziali ne scolpisce le forme incorniciandolo e puntando ad esaltarlo. Ecco quindi che il metallo dai colori naturali ed un plafone luminoso materializzano l'assenza rendendola viva e teatrale nella composizione delle forme.

*The confrontation with the concept of emptiness, which is ambiguous to represent, has always been the result of continuous debate, precisely because of the meaning of its existence and the laws that govern it.*

*Aria with its essential lines sculpts its shapes by framing it and aiming to enhance it. This is why the metal with its natural colors and a luminous ceiling materialize the absence, making it alive and theatrical in the composition of the forms.*





# MOONLIGHT

DESIGNED BY MATTEO ZORZENONI



# MOONLIGHT

Moonlight è una collezione di lampade dalla forte connotazione grafica. Scegliendo fra tre disegni diversi di lamiera metalliche sagomate ed applicabili tramite dei magneti alla struttura è possibile customizzare in maniera differente ogni lampada. Viene fornita con sistema di illuminazione integrato, disponibile in due dimensioni e nelle finiture nero opaco e ottone satinato.

*Moonlight is a collection of lamps with a strong graphic connotation. Choosing between three different designs of shaped metal sheets and applicable by means of magnets to the structure you can customize each lamp in a different way. Comes with integrated lighting system, available in two sizes and in matt black and satin brass finishes.*







# BELLA TUBE

DESIGNED BY MM LAMPADARI WORKSHOP



# BELLA TUBE

Un piccola sfera di vetro di Murano dalle molte sfaccettature è l'elemento decorativo di questa sospensione che ricorda la cristalleria più preziosa e conferisce alla luce circostante giochi di riflessi eleganti, mantenendo nel piano sottostante una luce funzionale e puntuale.

*A small sphere of Murano glass with many facets is the decorative element of this pendant that recalls the most precious glassware and gives the surrounding light a play of elegant reflections, keeping in the floor below a functional and punctual light.*





# RIPPLE

DESIGNED BY MM LAMPADARI WORKSHOP



# RIPPLE

Le sinuose onde concentriche del vetro di Murano, ricordano il movimento superficiale dell'acqua distribuendo uniformemente la luce. Un disco di metallo ne incornicia le forme evidenziandole e dirige la luce sul piano sottostante.

*The sinuous concentric waves of Murano glass recall the surface movement of water, uniformly distributing the light. A metal disc frames the shapes, highlighting them and directing the light onto the surface below.*





# BALLOON

DESIGNED BY MATTEO ZORZENONI



# BALLOON

Balloon prende spunto da un prodotto già presente nel catalogo classico.

Rivisto e ripulito di qualsiasi fronzolo viene presentato in chiave contemporanea, mettendone in risalto la struttura. Presentato nelle finiture nero opaco ed oro zecchino, la base in ceramica accompagna con grazia il paralume in tessuto che nei dettagli ne segue il colore principale. Una elegante luce diffusa ed eterea completa l'eleganza con cui la lampada si presenta già al primo sguardo.

*Balloon takes its cue from a product already present in the classic catalog.*

*Revised and cleaned of any frills, it is presented in a contemporary key, highlighting its structure. Presented in matt black and pure gold finishes, the ceramic base gracefully accompanies the fabric lampshade, which in the details follows the main colour. An elegant diffused and ethereal light completes the elegance with which the lamp appears at first glance.*





# BALLOTON

DESIGNED BY MATTEO ZORZENONI



# BALLOTON

Balloton riporta alla luce la tecnica veneziana del soffiaggio del vetro e la reinterpreta in questa suggestiva collezione di lampade in metallo. Moduli disponibili singolarmente o in grandi composizioni a "chandelier", disponibili ora anche nella versione mini che è adattabile a plafoni già in uso per altre gamme di prodotto.

*Balloton brings to light the Venetian technique of glass blowing and reinterprets it in this evocative collection of metal lamps. Modules available individually or in large "chandelier" compositions, now also available in the mini version that can be adapted to ceilings already in use for other product ranges.*







# CHILL

DESIGNED BY MASSIMO ZAZZERONI



# CHILL

Chill evoca le linee fluide e semplici dell'arte e del design, dove la grafica si fonde alla semplicità delle forme.

Le strutture in metallo verniciato opaco sostengono sfere metalliche con illuminazione a led direzionabili e boule di vetro soffiato muranese che permettono differenti modalità di illuminazione, diffusa e puntuale.

*Chill evokes the fluid and simple lines of art and design, where graphics blend with the simplicity of forms. The structures in opaque painted metal, support metal spheres with directional Led lighting and Murano blown glass boule that allow different modes of lighting, diffused and punctual.*





# LAYLA

DESIGNED BY SERENA CONFALONIERI



# LAYLA

Il profilo riprende la forma delle vecchie lampade ad olio e dei vecchi lumini da notte, oggetti caldi e rassicuranti che conferiscono alla stanza un'atmosfera intima, richiamando un immaginario domestico. Il nome Layla, infatti, deriva dal vocabolo arabo ليلى (laylah) che vuol dire "notte", e suggerisce un utilizzo della lampada negli ambienti più intimi, accompagnando fino al momento del sonno.

*Its shape reminds the old oil lamps and nightstand lights, warm and reassuring objects that give the room an intimate atmosphere, recalling a domestic imaginary. The name Layla derives from the Arabic word ليلى (laylah) which means "night" and suggests a use of the lamp in the most intimate spaces: it keeps us company until the moment of sleep.*

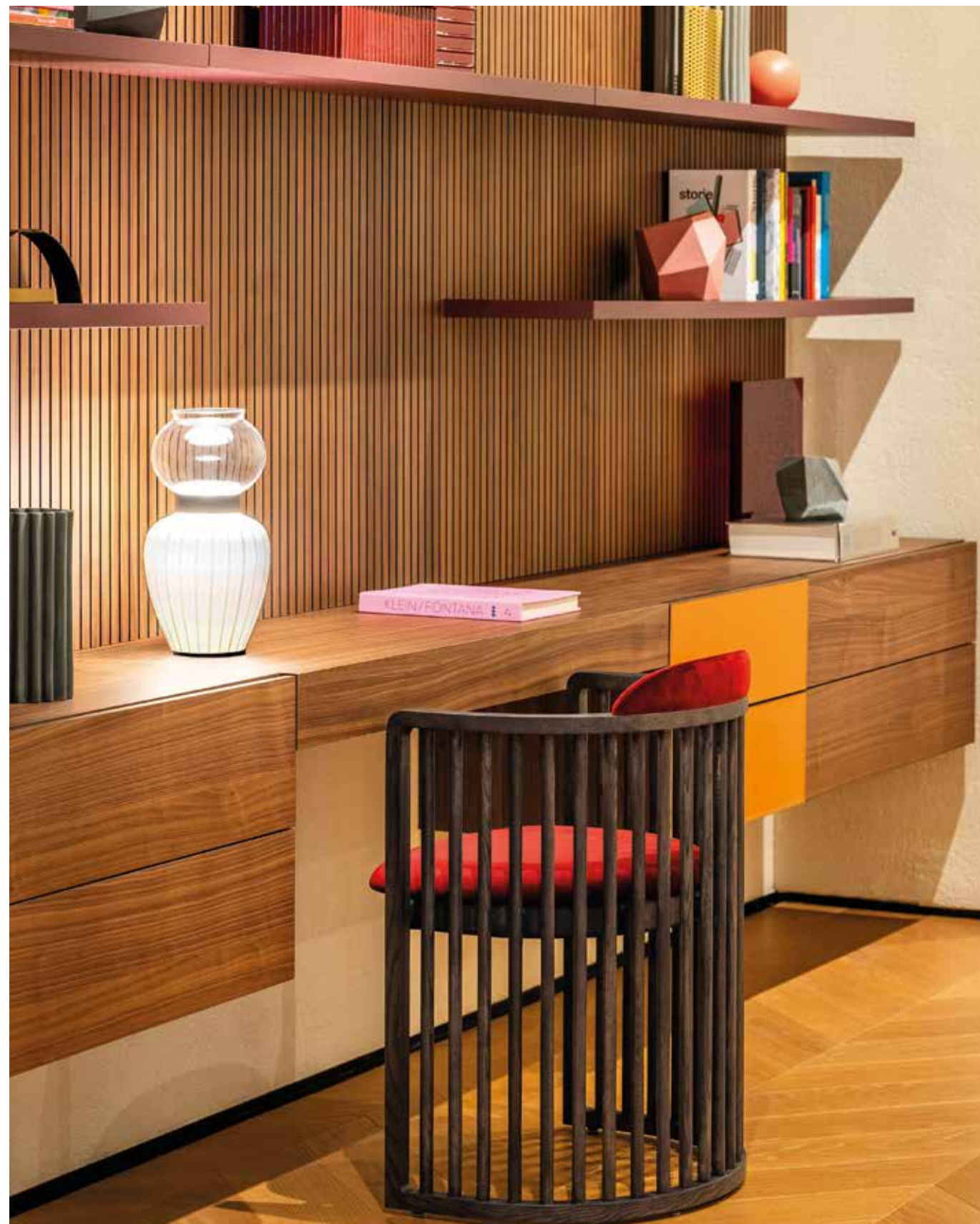



# LEAF

DESIGNED BY MATTEO ZORZENONI



# LEAF

Ispirata alla natura e all'armonia degli spazi, Leaf propone una struttura metallica leggera ed eclettica in metallo, con diffusore in vetro frutto di un'accurata ricerca progettuale. Avulsa da qualsiasi stile, le sue forme pulite che ne esaltano la silhouette nello spirito del minimalismo, si integra perfettamente in qualsiasi ambiente evidenziandone il carattere.

*Inspired by nature and the harmony of space, Leaf proposes a light and eclectic metal structure, with glass diffuser, the result of careful design research. It is free from any style, its clean shapes that enhance the silhouette in the spirit of minimalism, it integrates perfectly into any environment highlighting its character.*







# MAESTRO

DESIGNED BY MM LAMPADARI WORKSHOP



# MAESTRO

L'intramontabile forma sferica reinterpretata con una compatta superficie ondata che esalta la diffusione della luce. La famiglia comprende lampada a sospensione in due misure, lampada da tavolo e lampada da terra. Diffusore in vetro di Murano bianco latte sfumato e struttura in metallo verniciato.

*The timeless spherical shape reinterpreted with a compact wave surface that enhances the dissemination of Light. The family includes pendant lamp in two sizes, table lamp and floor lamp. Diffuser in Murano white shaded milk glass and painted metal structure.*





# MATA

DESIGNED BY SERENA CONFALONIERI



# MATA

La nuova collezione di lampade a parete disegnata da Serena Confalonieri è un omaggio a Mata Hari, la spia danzatrice dell'inizio del secolo scorso che ammaliava i potenti e ne carpiva i segreti, spogliandosi lentamente dei suoi veli fino a rimanere vestita solo dei suoi gioielli. Sono proprio i gioielli decò indossati dalla spia l'ispirazione per questa collezione di appliques, pensata per impreziosire le pareti grazie ad un mix di forme geometriche e materiali con una sovrapposizione di vetro colato in lastra opalescente e volumi in elegante marmo. Gli elementi in vetro e quelli in marmo possono essere accostati con grande libertà, aprendo la strada ad un'ampia gamma di modelli e abbinamenti cromatici.

*The new collection of wall lamps designed by Serena Confalonieri is a tribute to Mata Hari, the dancing spy of the beginning of the last century who enchanted the powerful and grasped their secrets, slowly stripping off her veils until she was dressed only in her jewels. It is precisely the deco jewelry worn by the spy that inspires this collection of appliques, designed to embellish walls thanks to a mix of geometric shapes and materials with a overlapping of cast glass in opalescent slab and volumes in elegant marble. Glass and marble elements can be combined with great freedom, paving the way for a wide range of models and chromatic combinations.*





# MILA

DESIGNED BY CHIARA ANDREATTI STUDIO SALARIS

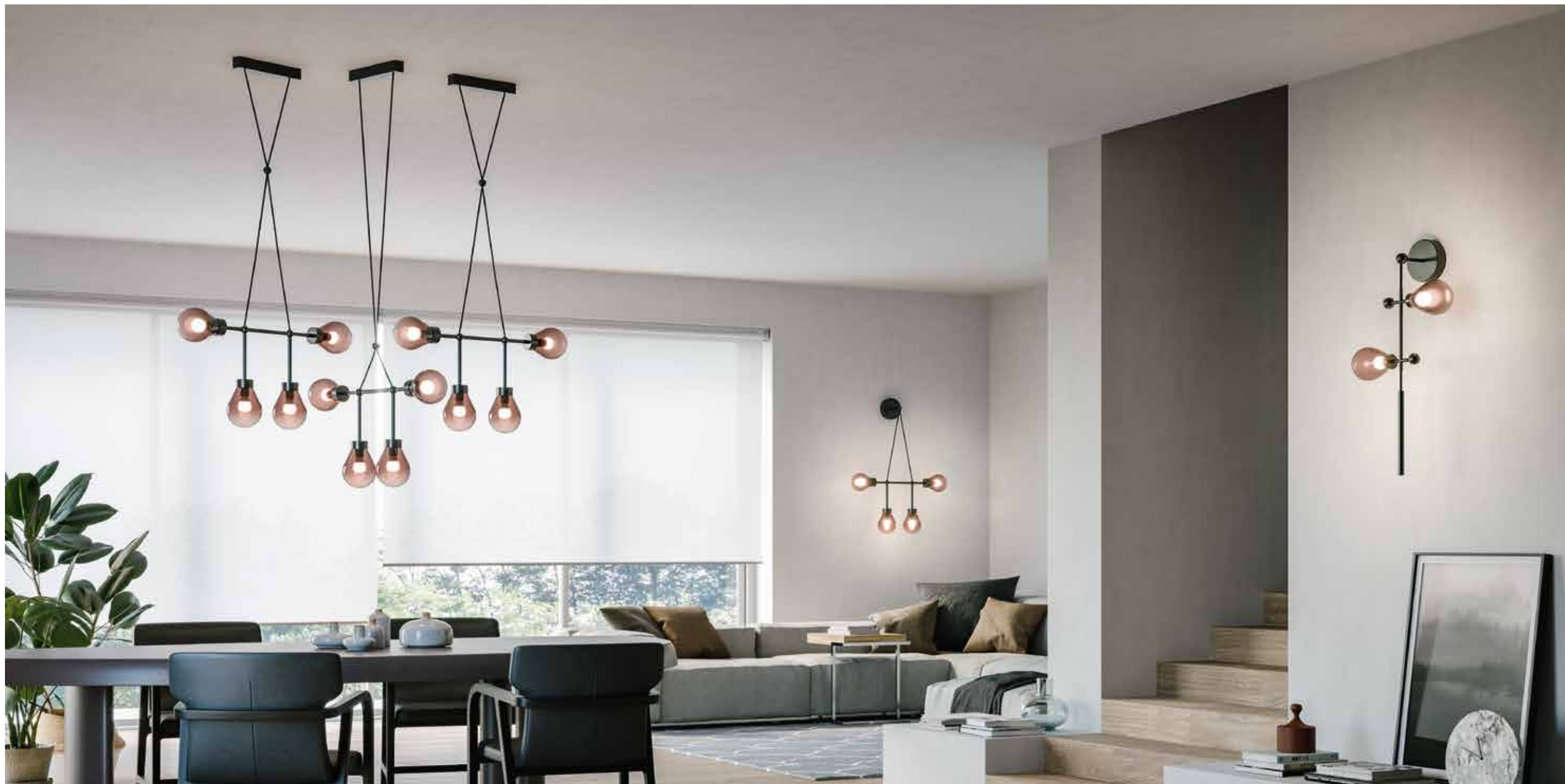

# MILA

Ispirata alle gloriose lampade dell'Art Decò ne adotta gli stilemi con una rilettura dal sapore contemporaneo. Elemento cardine del progetto è il cavo elettrico, parte essenziale del linguaggio estetico del progetto. Un elemento regolabile che consente di variarne le linee grafiche e l'aspetto formale. Struttura in metallo verniciato colore carbon black, globi in vetro fumè rosato.

*Inspired by the glorious lamps of Art Deco, it adopts their stylistic features with a contemporary reinterpretation. The key element of the project is the electric cable, an essential part of the aesthetic language of the project. An adjustable element that allows to vary the graphic lines and the formal appearance. Structure in carbon black painted metal, globes in smoked pink glass.*





# PINEAPPLE

DESIGNED BY MATTEO ZORZENONI



# PINEAPPLE

Il restyling della tradizione artigiana ha dato vita ad una collezione originale e affascinante, dove il vetro lucido di Murano soffiato su stampo del paralume si sposa finemente con la base in ceramica in texture materica romboidale. Disponibile in vari abbinamenti cromatici che lo rendono un elemento decorativo molto pop.

*The restyling of the artisan tradition has given life to an original and fascinating collection, where the shiny Murano glass blown on the mould of the lampshade blends finely with the ceramic base in rhomboidal material texture. Available in various color combinations that make it a very pop decorative element.*





# RAIN

DESIGNED BY CENTRO STILE MM LAMPADARI



# RAIN

Le suggestioni che la pioggia suscita cambia anche la visione del mondo che ci circonda cadendo dal cielo e rendendo suggestivo ogni luogo.

E proprio come la pioggia che scende leggera e diligente anche gli elementi di queste lampade ridisegnano l'ambiente con costanti intrecci di fili obliqui a formare una trama di bulbi in vetro specchiato lucenti.

*The suggestions that the rain provokes also change the vision of the world that surrounds us, falling from the sky and making every place evocative.*

*Just like the rain that falls lightly and diligently, the elements of these lamps redesign the environment with constant interlacing of oblique threads to form a weave of shiny mirrored glass bulbs.*





# WHALE

DESIGNED BY LEO DE CARLO MIST

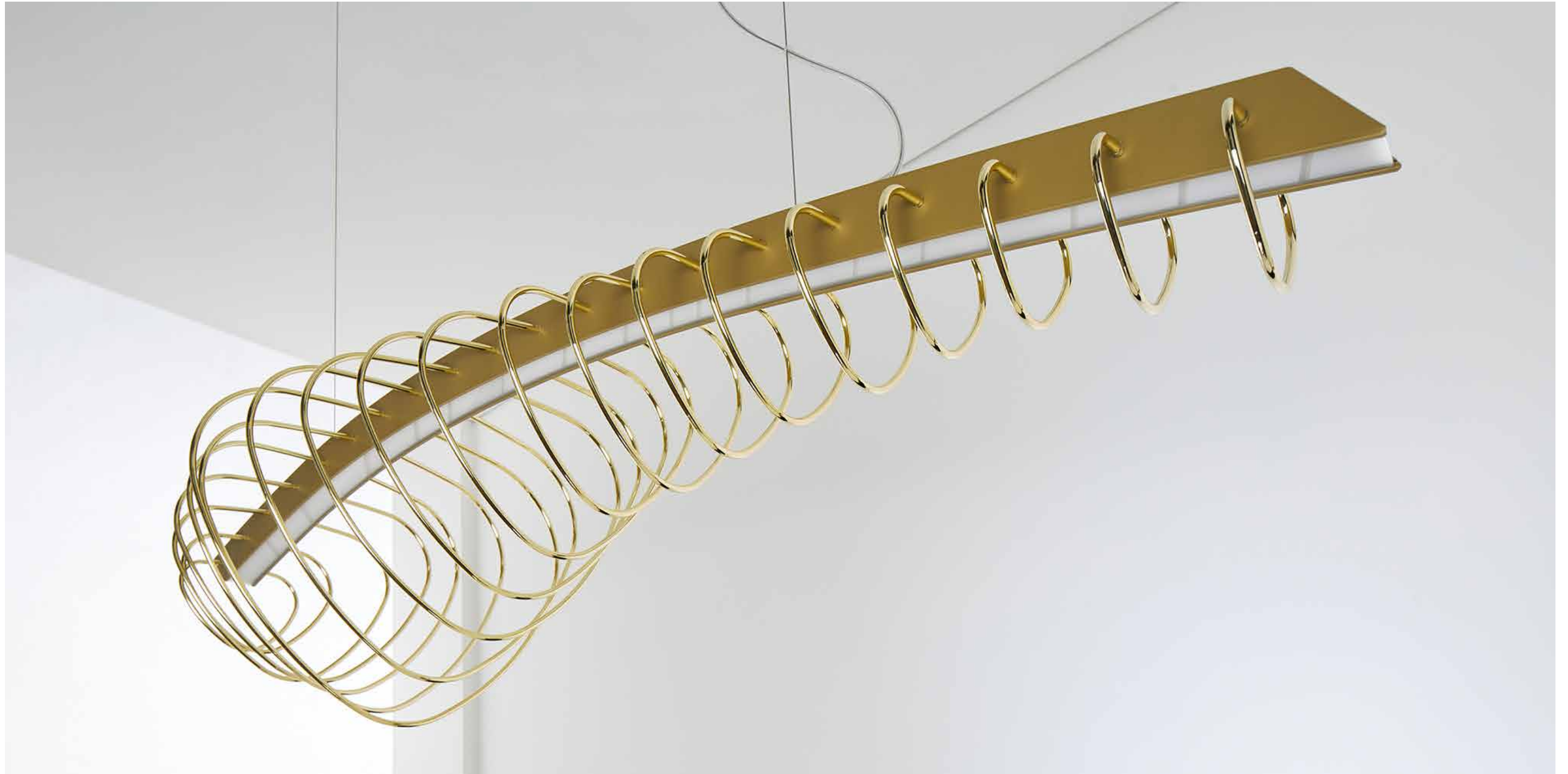

# WHALE

Whale rappresenta il gesto di trasformare un simbolo della potenza naturale come una balena in qualcosa di rassicurante e utile: il tentativo di addomesticare la forma naturale attraverso la tecnica per ricordarci che comunque, nella profondità dei nostri cuori, è la natura l'elemento che ci sovrasta, ci ispira e ci guida.

*Whale represents the gesture of transforming a symbol of natural power as a whale into something reassuring and useful: anyway, the attempt to domesticate the natural form through the technique to remind us that, in the depths of our hearts, is nature the element that dominates us, inspires us and guides us.*



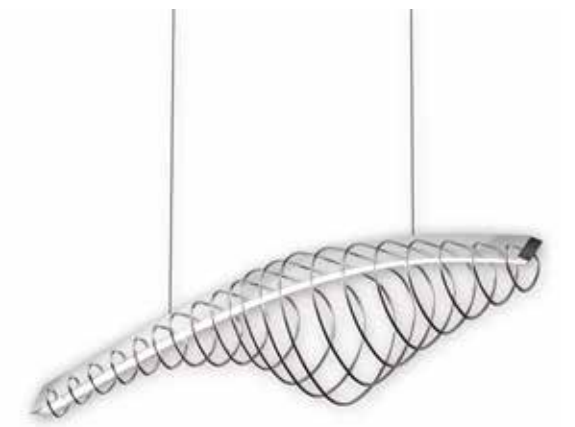

# KINGDOM

DESIGNED BY LEO DE CARLO MIST

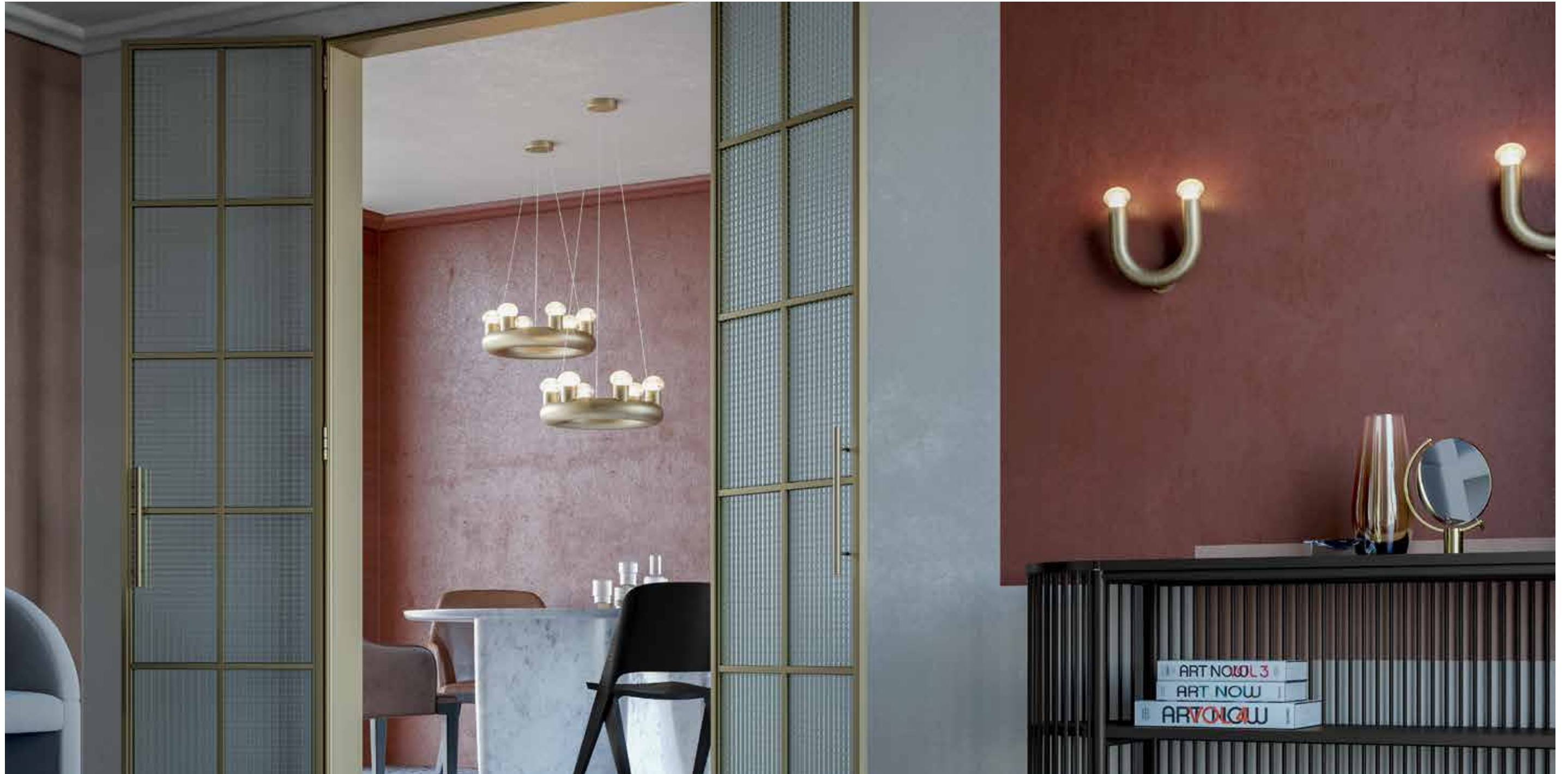

# KINGDOM

Nel medioevo e nel rinascimento, l'illuminazione delle abitazioni era ottenuta mediante candelabri e lampade ad olio organizzate in maniera cadenzata su anelli in ferro o legno. Kingdom è la reinterpretazione di questo archetipo di lampada, adattato al gusto contemporaneo: un semplice anello tubolare da cui spuntano, in maniera ripetuta e ordinata, delle "candele tecnologiche" arricchite da un elemento decorativo in vetro lavorato.

*In the Middle Ages and the Renaissance, the lighting of dwellings was obtained using candelabra and oil lamps arranged in a cadence on iron or wood rings. Kingdom is the reinterpretation of this lamp archetype, adapted to the contemporary taste: a simple tubular ring from which emerge, in a repeated and orderly manner, of "technological candles" enriched by a decorative element in worked glass.*





# PARAMOUNT

DESIGNED BY ROBERTO FAVARETTO



# PARAMOUNT

Una linea unica e vigorosa controfirma le forme di Paramount, che allontana deliberatamente la ricerca della varietà decorativa dando varie possibilità teoriche di combinazioni allo stesso tempo.

La scelta di utilizzare meno materiale possibile rispecchia, infatti, l'idea che ciò che immediatamente è comprensibile, è immediato e più ragionevole. Essenziale.

*A unique and vigorous line countersigns the forms of Paramount that deliberately runs away the search of the decorative variety giving various theoretical possibilities of combinations at the same time. The choice to use less material possible it mirrors, in fact, the idea that what immediately is comprehensible, is immediate and more reasonable. Essential.*





## ARCH

Lampada in metallo, verniciato o trattamento galvanico, e vetro borosilicato  
Metal lamp, painted or galvanic treatment and borosilicate glass

Struttura / Frame

V2828  
Canna di fucile  
Gunmetal grey

V2832  
Canna di fucile  
con particolari  
ottone lucido  
Gunmetal grey  
with glossy  
brass details

V0216  
Ottone lucido  
Glossy brass

Diffusore / Diffuser

Vetro bianco lucido  
White glossy glass

Su richiesta / On request

Vetro ambra  
Amber glass

Vetro fumè  
Fumè glass

Illuminazione / light source

5W G9

Dimmerabile con convertitore DALI su richiesta  
Dimmable with DALI converter on request

Utilizzo da interno  
Indoor use

Prodotto dimmerabile  
Dimmable

Lampadina non compresa / Bulb not included.

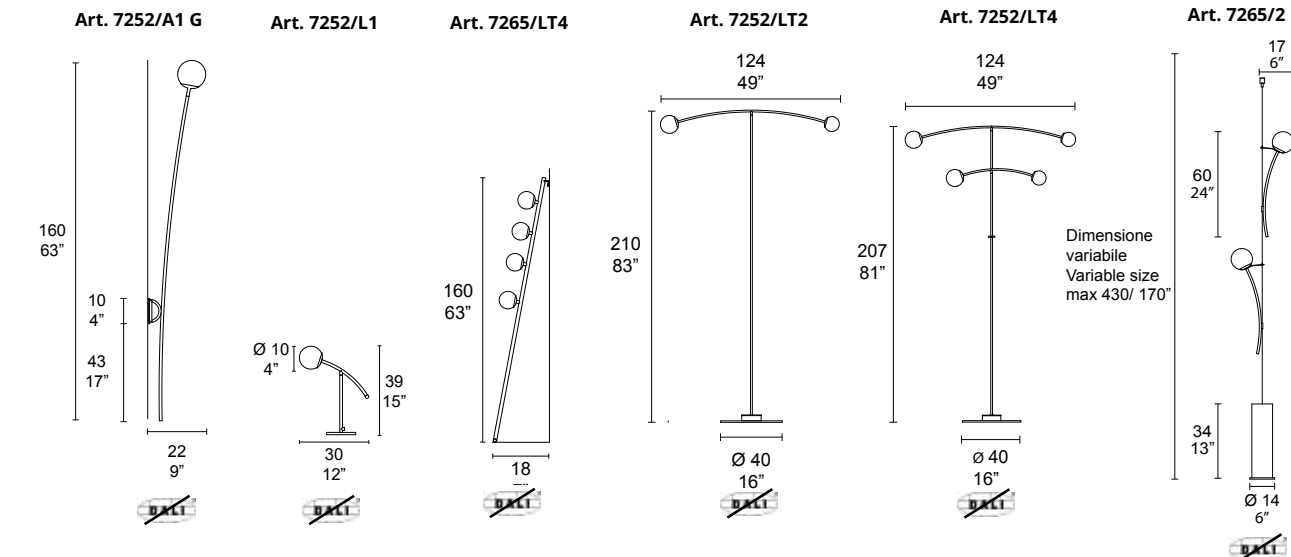
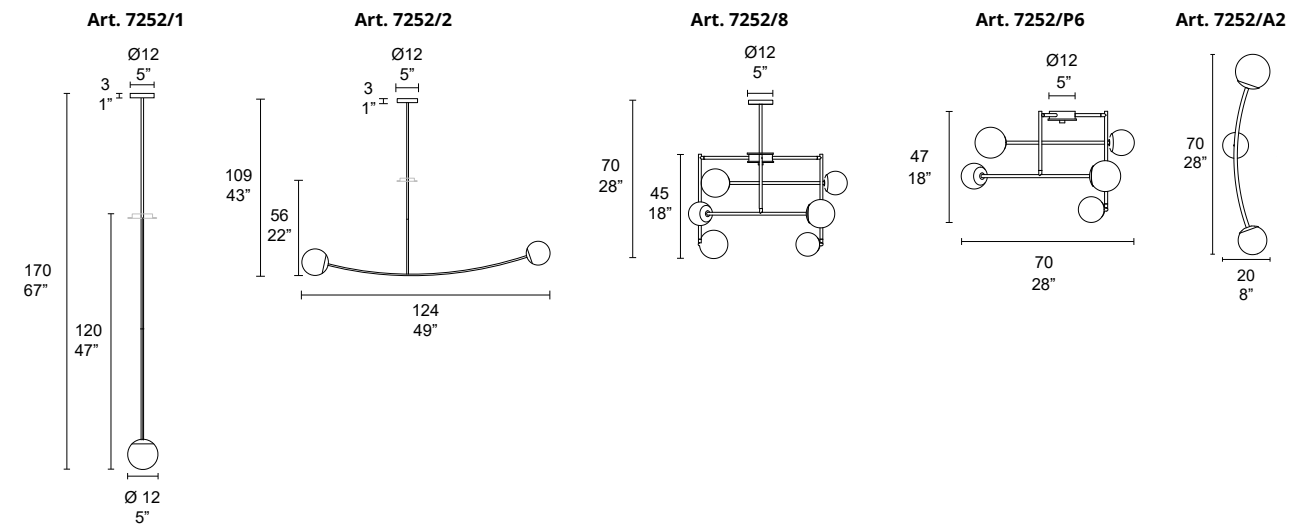

## M.MM

## ARIA

Lampada in metallo, verniciato o trattamento galvanico, con diffusore in PMMA  
Metal lamp, painted or galvanic treatment, with PMMA diffuser

Struttura / Frame

V2907  
Bianco Opaco  
Matt white

V0199  
Nero opaco  
Matt black

V2962  
Ottone Brunito  
galvanico  
galvanic burnished  
brass

Diffusore / Diffuser

PMMA Bianco opale  
PMMA Ice white

Illuminazione / light source

10W E14 5W G9

Dimmerabile con convertitore DALI su richiesta  
Dimmable with DALI converter on request

Utilizzo da interno  
Indoor use

Prodotto dimmerabile  
Dimmable

Lampadina non compresa / Bulb not included.

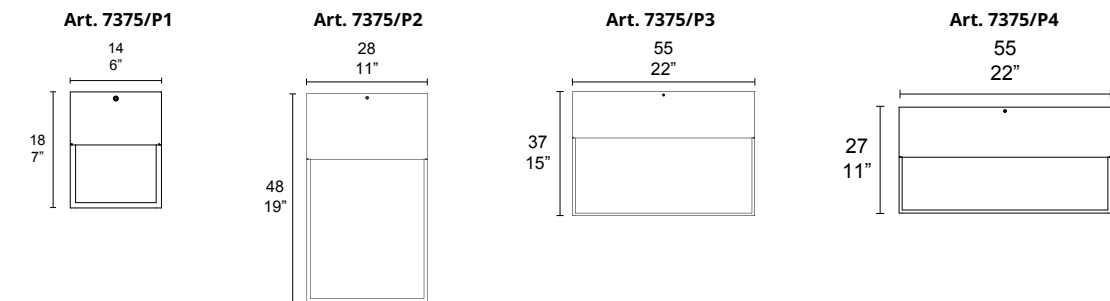
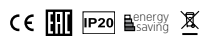

## BALLOON

Lampada in ceramica con paralume in tessuto  
Ceramic lamp with fabric shade

Struttura / Frame

V0199  
Nero opaco  
Matt black

V0197  
Oro 24K  
Gold 24K

Diffusore / Diffuser

Paralume in tessuto bianco / elementi Oro  
White fabric shade / Gold elements

Paralume in tessuto bianco / elementi neri  
White fabric shade / black elements

Illuminazione / light source

11W shape T37 max Ø37mm

Dimmerabile con convertitore DALI su richiesta  
Dimmable with DALI converter on request

Utilizzo da interno  
Indoor use

Prodotto dimmerabile  
Dimmable

Lampadina non compresa / Bulb not included.

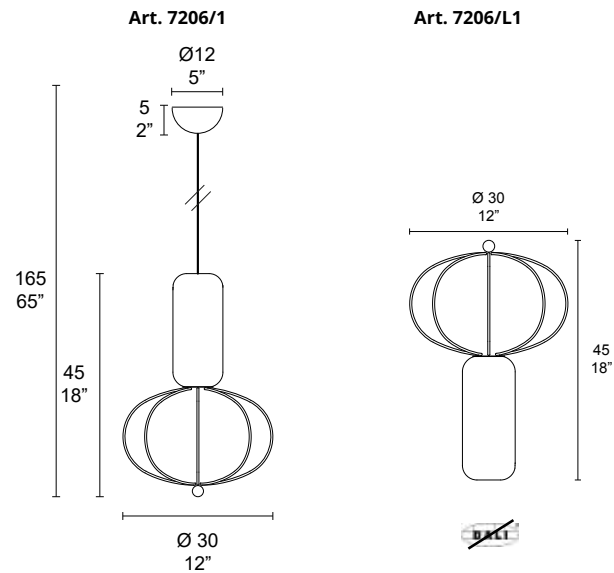

## M.MM

## BALLOTON

Lampada in metallo, verniciato o trattamento galvanico, e vetro murano balloton  
Metal lamp, painted or galvanic treatment, and murano balloton glass

Struttura / Frame

V0199  
Nero opaco  
Matt black

V2907  
Bianco Opaco  
Matt White

V2806  
Rame lucido  
Glossy copper

V0216  
Ottone lucido  
Glossy brass

Diffusore / Diffuser

Balloton trasparente  
Crystal Balloton

Balloton Fumé  
Smoked balloton

Vetro bianco sfumato  
White shaded glass

Illuminazione / light source

20W E27 10W E14 5W G9

Dimmerabile con convertitore DALI su richiesta  
Dimmable with DALI converter on request

Utilizzo da interno  
Indoor use

Prodotto dimmerabile  
Dimmable

Lampadina non compresa / Bulb not included.

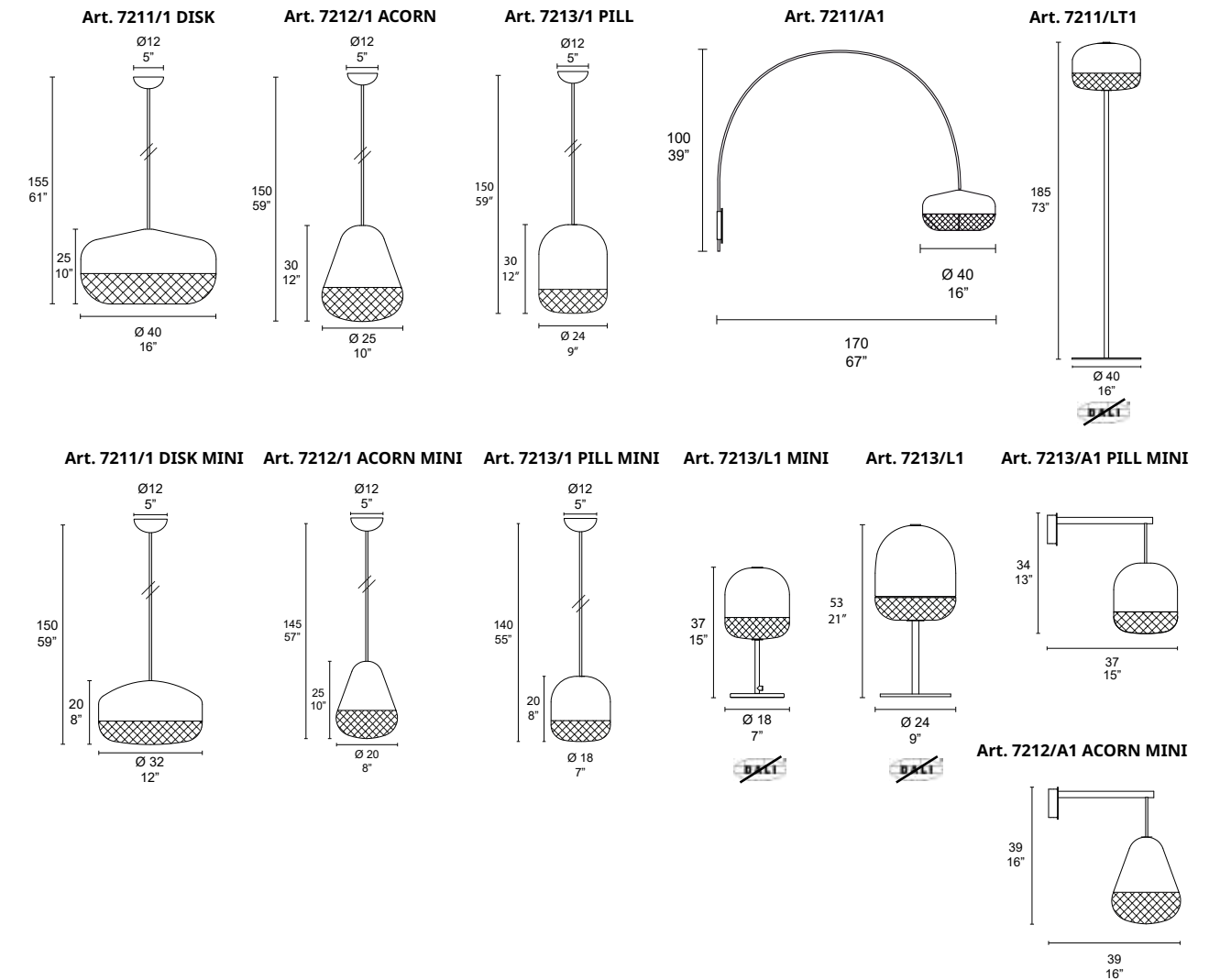
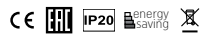

## BELLA TUBE

Lampada in metallo verniciato e vetro murano soffiato  
Painted metal and murano blown glass lamp

Struttura / Frame

● V0199  
Nero opaco  
Matt black

Diffusore / Diffuser

● Fumè  
Fumè

Illuminazione / light source

5W G9 220V/240V



Dimmerabile con convertitore DALI su richiesta  
Dimmable with DALI converter on request



Utilizzo da interno  
Indoor use



Prodotto dimmerabile  
Dimmable

Lampadina non compresa / Bulb not included.



Art. 7395/1

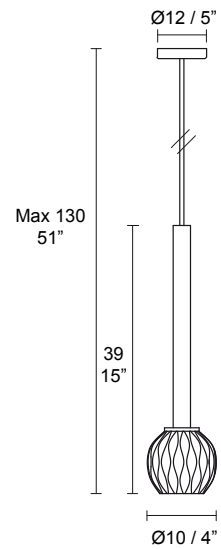

Art. 7395/1  
Senza rosone  
Without canopy

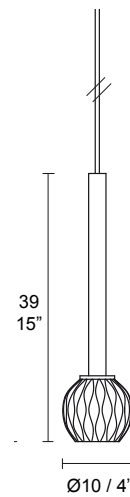

## M.MM

## CHILL

Lampada in metallo verniciato, diffusori in vetro murano soffiato e diffusori direzionabili PMMA  
Painted metal lamp, Murano blown glass and directional PMMA diffusers

Struttura / Frame

● V0199  
Nero opaco  
Matt black

○ V2907  
Bianco opaco  
Matt white

Diffusore / Diffuser

● Fumè satinato  
Satin fumè

○ PMMA opale  
Ice white

Illuminazione / light source

LED 20W E27 + LED BOARD 4,5W 3000 K

Lampadina non compresa / Bulb not included.



Dimmerabile con convertitore DALI su richiesta  
Dimmable with DALI converter on request



Utilizzo da interno  
Indoor use



Prodotto dimmerabile  
Dimmable



Tensione d'uso  
Voltage



Modulo LED integrato sostituibile  
Integrated replaceable LED module

Art. 7330/6

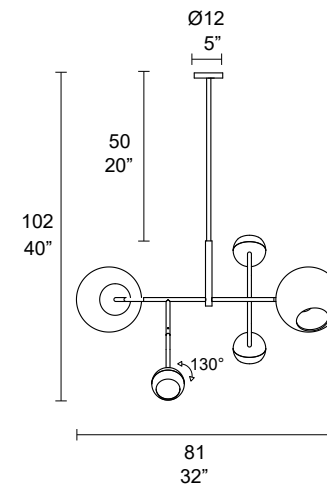

Art. 7330/A2

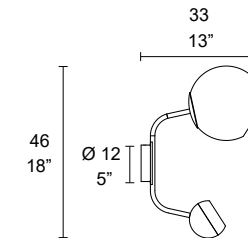

## CHOOPS

Lampada in metallo verniciato e vetro soffiato  
Painted metal and blown glass lamp

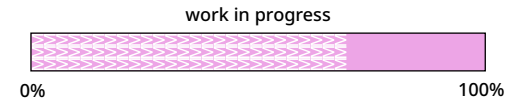

Art. 7431/1

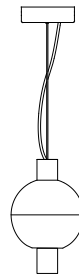

Art. 7431/LT1

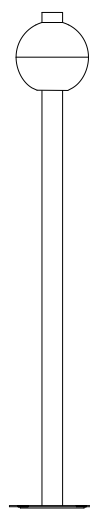

Art. 7431/L1

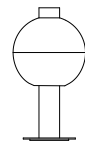

## M.MM

## CLESSIDRA LED

Lampada in metallo verniciato dettagli galvanici e diffusore PMMA  
Painted metal lamp galvanic details, PMMA diffuser

Struttura / Frame

- V2852  
Bianco opaco con particolari in  
ottone lucido  
Matt white with glossy brass  
details
- V2853  
Nero opaco con particolari in  
ottone lucido  
Matt black with glossy brass  
details

Diffusore / Diffuser

- PMMA Bianco opale  
PMMA Ice white

Illuminazione / light source

- LED BOARD 4,5W 3000°K
- LED BOARD 8W 3000°K



Dimmerabile con convertitore DALI su richiesta  
Dimmable with DALI converter on request



Utilizzo da interno  
Indoor use



Prodotto dimmerabile  
Dimmable



Tensione d'uso  
Voltage



Modulo LED integrato sostituibile  
Integrated replaceable LED module

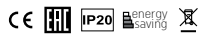

## CLESSIDRA G9

Lampada in metallo verniciato dettagli galvanici e diffusore PMMA  
Painted metal lamp galvanic details, PMMA diffuser

Struttura / Frame

- V2852  
Bianco opaco con particolari in  
ottone lucido  
Matt white with glossy brass  
details
- V2853  
Nero opaco con particolari in  
ottone lucido  
Matt black with glossy brass  
details

Diffusore / Diffuser

- PMMA Bianco opale  
PMMA Ice white

Illuminazione / light source

- 5W G9



Dimmerabile con convertitore DALI su richiesta  
Dimmable with DALI converter on request



Utilizzo da interno  
Indoor use



Prodotto dimmerabile  
Dimmable

Lampadina non compresa / Bulb not included.

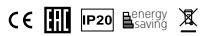

Art. 7331/2 (1 pendente/pendant)

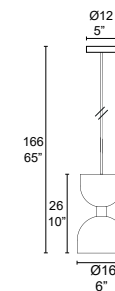

Art. 7331/A2

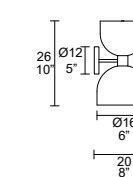

Art. 7331/8 (4 pendenti/pendants)

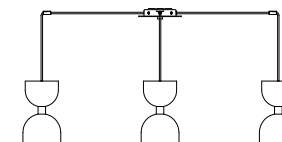

Art. 7331/16 (8 pendenti/pendants)

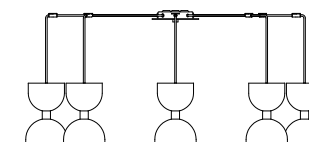

Art. 7331/48 (24 pendenti/pendants)

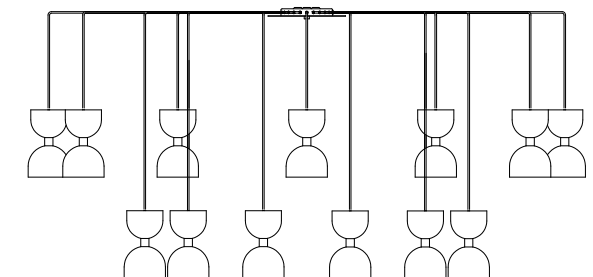



composizioni fornite con decentratori e 290cm di cavo utile  
compositions supplied with ceiling clips and 290cm of usable cable

**CODE**

Lampada in metallo verniciato o trattamento galvanico con diffusore in PMMA  
Painted metal lamp or galvanic treatment with PMMA diffuser

Struttura / Frame

-  V2905  
Ottone ossidato interno nero  
Burnished brass black interior
-  V2916  
Ferro Decapato interno nero  
Pickled iron black interior
-  V0199  
Pelle nera interno nero  
Black leather black interior

Diffusore / Diffuser

-  Bianco opale  
Ice white

Illuminazione / light source

 STRIP LED 25/ 35/ 45 W 3000K

 Dimmerabile con convertitore DALI su richiesta  
Dimmable with DALI converter on request

 Utilizzo da interno  
Indoor use

 Prodotto dimmerabile su richiesta  
Dimmable on request

 Tensione d'uso  
Voltage

 Modulo LED integrato sostituibile  
Integrated replaceable LED module







**M.MM**



**DOTS**

Lampada in metallo, verniciato o trattamento galvanico e vetro borosilicato  
Metal lamp, painted or galvanic treatment with and borosilicate glass

Struttura / Frame

-  V2821  
Nero opaco con dettagli foglia oro  
Matt black with gold leaf details
-  V2809  
Bianco lucido con dettagli foglia rame  
Glossy white with copper leaf details
-  V2806  
Rame lucido  
Glossy copper
-  V0216  
Ottone lucido  
Glossy brass

Diffusore / Diffuser

-  Vetro bianco lucido  
White glossy glass
- Su richiesta / On request
  -  Vetro ambra  
Amber glass
  -  Vetro fumè  
Fumè glass

Illuminazione / light source

 5W G9

 Dimmerabile con convertitore DALI su richiesta  
Dimmable with DALI converter on request

 Utilizzo da interno  
Indoor use

 Prodotto dimmerabile  
Dimmable

Lampadina non compresa / Bulb not included.

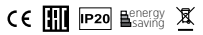

**M.MM**

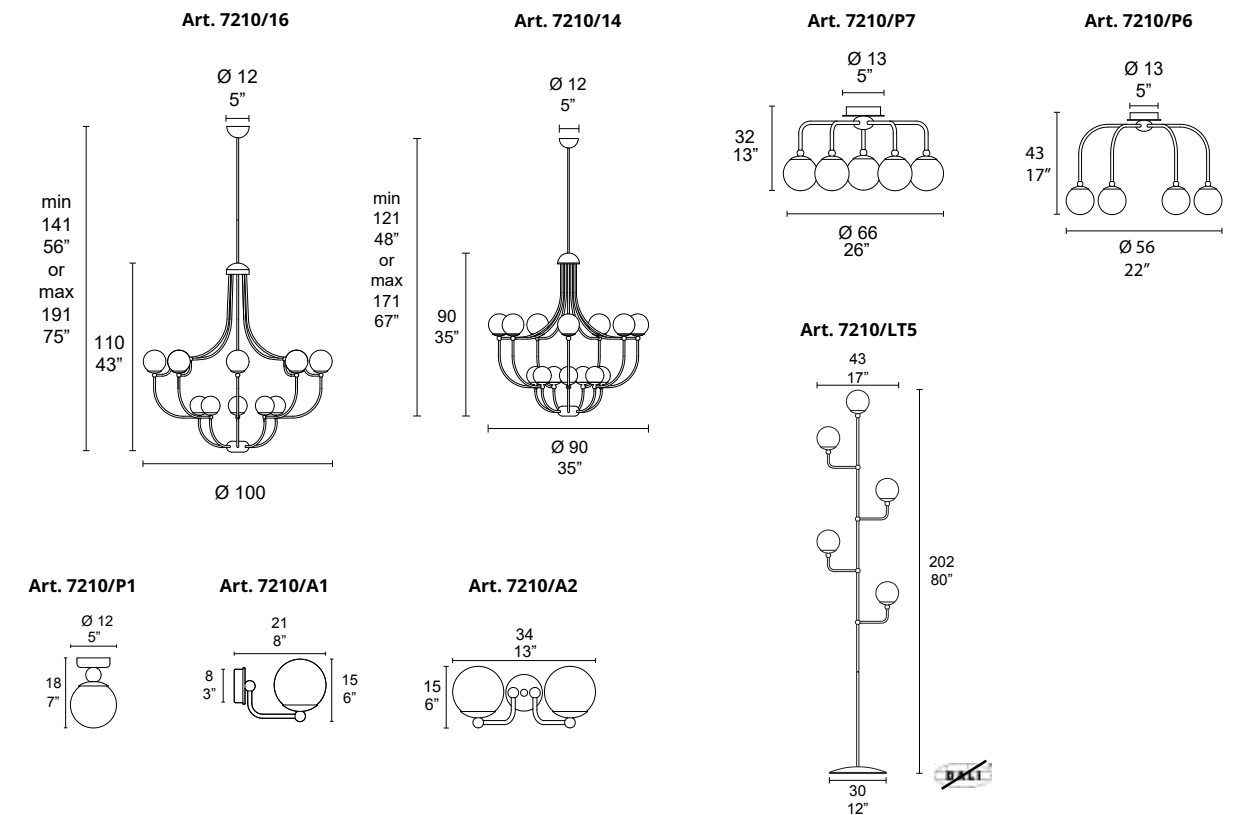
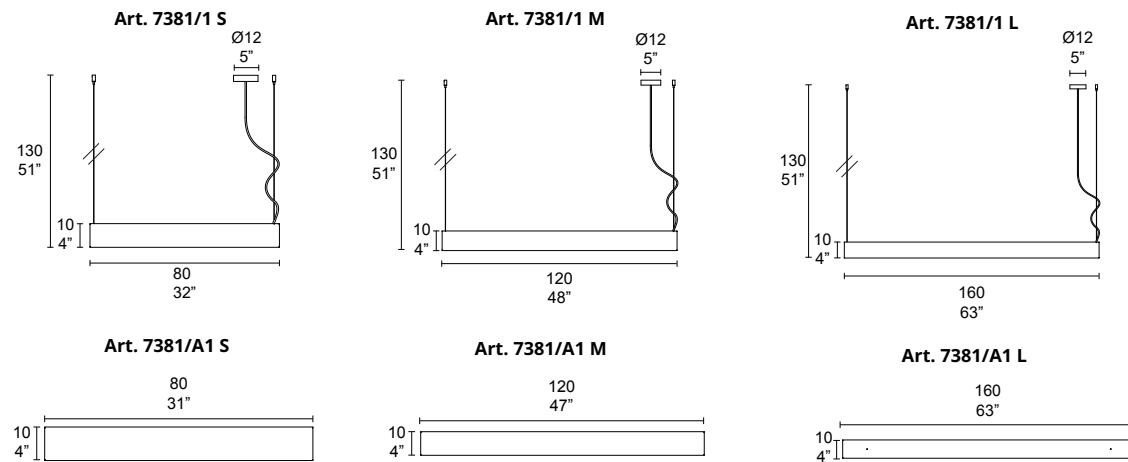

## KINGDOM

Lampada in metallo verniciato o trattamento galvanico con diffusore vetro borosilicato  
Painted metal lamp or galvanic treatment and borosilicate glass

Struttura / Frame

V2907  
Bianco Opaco  
Matt White

V2962  
Brunito galvanico  
Galvanic burnished

Diffusore / Diffuser

Vetro rigato trasparente  
Transparent striped glass

Illuminazione / light source

10W E14 (C35)

 Dimmerabile con convertitore DALI su richiesta  
Dimmable with DALI converter on request

 Utilizzo da interno  
Indoor use

 Prodotto dimmerabile  
Dimmable

Lampadina non compresa / Bulb not included.

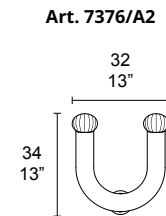
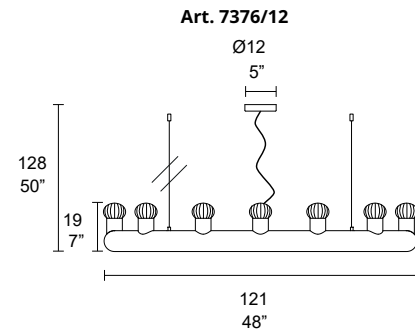
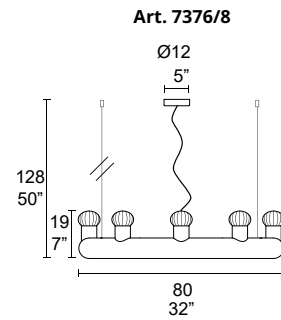
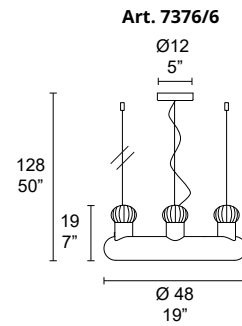

## M.MM

## LAYLA

Lampada in metallo e vetro di Murano  
Metal and Murano glass lamp

Struttura / Frame

V0199  
Nero opaco  
Matt black

Diffusore / Diffuser

filigrana bianca + cristallo  
filigree white + crystal

filigrana tabacco + blu  
filigree tobacco + blue

filigrana rosso + pesca  
filigree red + peach

filigrana blu + ambra  
filigree blue + amber

filigrana rubino + smeraldo  
filigree ruby + emerald

Illuminazione / light source

110 / 240V LED BOARD 6,1W 983lm 3000K

 Utilizzo da interno  
Indoor use

 Prodotto dimmerabile  
Dimmable

 Tensione d'uso  
Voltage

 Modulo LED integrato sostituibile  
Integrated replaceable LED module

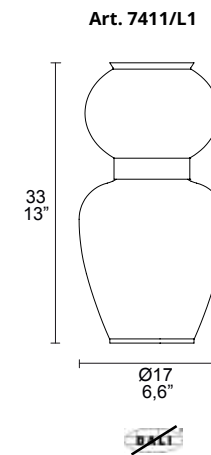
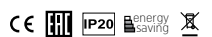

## LEAF G9

Lampada in metallo verniciato o trattamento galvanico con diffusore in vetro  
Painted metal lamp or galvanic treatment with glass diffuser





Struttura / Frame

- V0199  
Nero opaco  
Matt black
- V0216  
Ottone lucido  
Glossy brass
- V2807  
Rame satinato  
Satin copper
- V2805  
Ottone satinato  
Satin brass
- V2806  
Rame lucido  
Glossy copper
- V0266  
Brunito galvanico  
Burnished

Diffusore / Diffuser

- bianco  
White

Illuminazione / light source

-  5W G9
-  Dimmerabile con convertitore DALI su richiesta  
Dimmable with DALI converter on request
-  Utilizzo da interno  
Indoor use
-  Prodotto dimmerabile  
Dimmable

Lampadina non compresa / Bulb not included.



## M.MM

Art. 7208/2

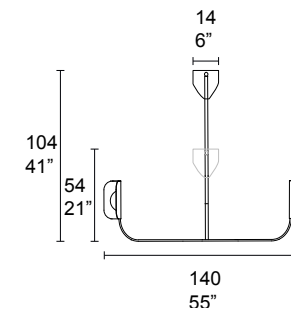

Art. 7208/4

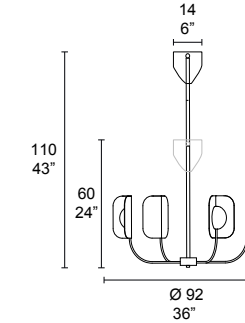

Art. 7208/8

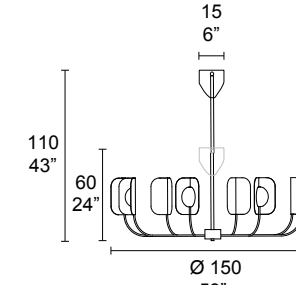

Art. 7208/12

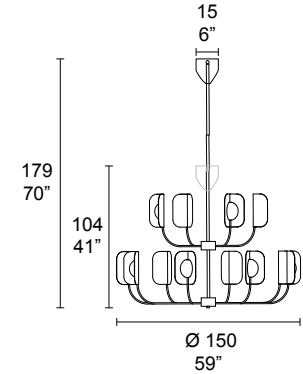

Art. 7208/24

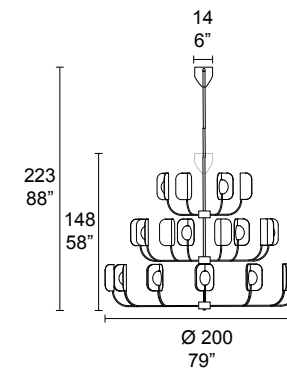

Art. 7208/A1

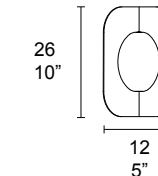

Art. 7208/LT3

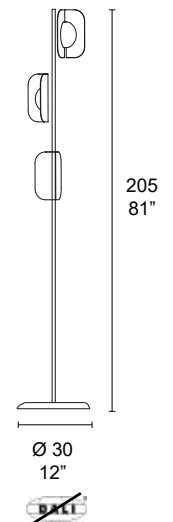

## LEAF LED

Lampada in metallo verniciato o trattamento galvanico con diffusore in vetro  
Painted metal lamp or galvanic treatment with glass diffuser





Struttura / Frame

- V0199  
Nero opaco  
Matt black
- V2900  
Ferro decapato  
Pickled iron
- V0216  
Ottone lucido  
Glossy brass
- V2807  
Rame satinato  
Satin copper
- V2805  
Ottone satinato  
Satin brass
- V2806  
Rame lucido  
Glossy copper
- V0266  
Brunito galvanico  
Burnished

Diffusore / Diffuser

- bianco  
White

Illuminazione / light source

- LED BOARD 4,5W 220-240V 3000°K
-  Dimmerabile con convertitore DALI su richiesta  
Dimmable with DALI converter on request
-  Utilizzo da interno  
Indoor use
-  Prodotto dimmerabile  
Dimmable
-  Tensione d'uso  
Voltage
-  Modulo LED integrato sostituibile  
Integrated replaceable LED module



## M.MM

Art. 7208/B1

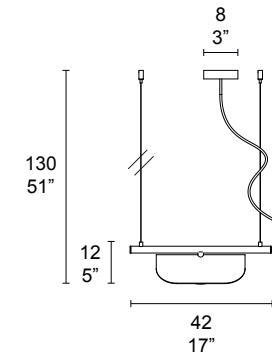

Art. 7208/B2

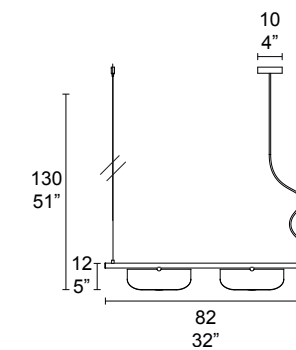

Art. 7208/B4

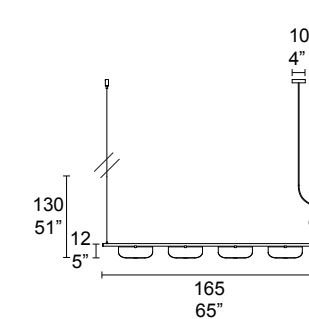

## LOOP

Lampada in metallo con trattamento galvanico e diffusore in vetro Murano  
Metal lamp with galvanic treatment and Murano glass diffuser

Struttura / Frame

V0216  
Ottone lucido  
Glossy brass

Diffusore / Diffuser

Vetro bianco  
White glass

Illuminazione / light source

Strip LED 7W 3000K

 Dimmerabile con convertitore DALI su richiesta  
Dimmable with DALI converter on request

 Utilizzo da interno  
Indoor use

 Prodotto dimmerabile  
Dimmable

 Tensione d'uso  
Voltage

 Modulo LED integrato sostituibile  
Integrated replaceable LED module

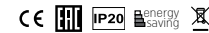

Art. 7423/A1

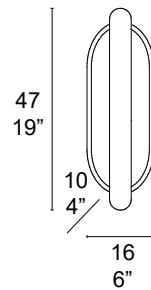

## M.MM

## MAESTRO

Lampada in metallo e vetro soffiato di Murano  
Lamp in metal and blown Murano glass

Struttura / Frame

V2178  
Nichel lucido  
Glossy Nickel

Diffusore / Diffuser

Bianco sfumato cristallo  
White shaded crystal

Illuminazione / light source

 20W E27

 Dimmerabile con convertitore DALI su richiesta  
Dimmable with DALI converter on request

 Utilizzo da interno  
Indoor use

 Prodotto dimmerabile  
Dimmable

Lampadina non compresa / Bulb not included.

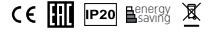

Art. 7403/1 S

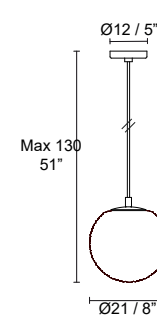

Art. 7403/1 L

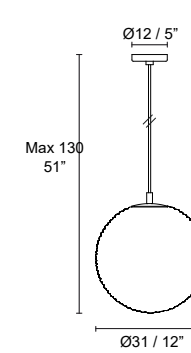

Art. 7403/L1 S

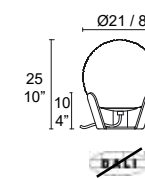

Art. 7403/L1 L

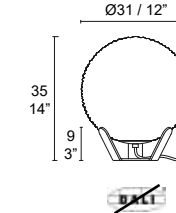

Art. 7403/LT1

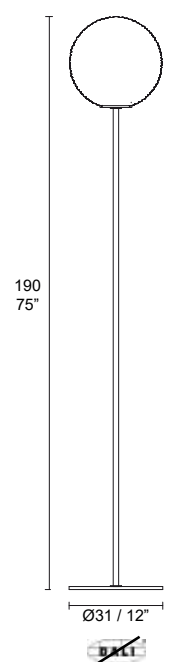

## MATA

Lampada in vetro colato, marmo e alluminio verniciato  
Lamp made of poured glass, marble and painted aluminum

Struttura / Frame

V2721  
Argento scuro  
Dark silver

Diffusore / Diffuser

Vetro monosatinato  
Single-sided glass

Vetro pesca monosatinato  
Single-sided peach glass

Marmo / Marble

Marmo Carrara  
Marble Carrara

Marmo Emperador  
Marble Emperador

Marmo Marquina  
Marble Marquina

Illuminazione / light source

LED BOARD 8W 800lm 3000K 110/240V



Dimmerabile con convertitore DALI su richiesta  
Dimmable with DALI converter on request



Utilizzo da interno  
Indoor use



Prodotto dimmerabile  
Dimmable



Tensione d'uso  
Voltage



Modulo LED integrato sostituibile  
Integrated replaceable LED module



Art. 7390/A1

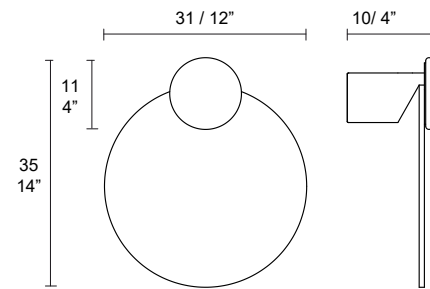

## M.MM

## MILA

Lampada in metallo verniciato e vetro borosilicato  
Painted metal lamp and borosilicate glass

Struttura / Frame

V0199  
Nero opaco  
Matt black

Diffusore / Diffuser

Vetro rosso prugna  
Red plum glass

Illuminazione / light source

10W E14 Classic P45



Dimmerabile con convertitore DALI su richiesta  
Dimmable with DALI converter on request



Utilizzo da interno  
Indoor use



Prodotto dimmerabile  
Dimmable

Lampadina non compresa / Bulb not included.



Art. 7383/4S

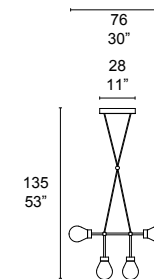

Art. 7383/4L

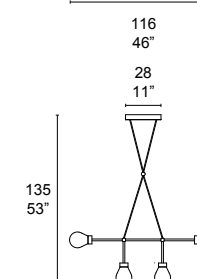

Art. 7383/A2

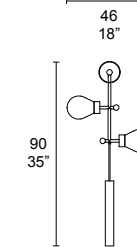

Art. 7383/A4

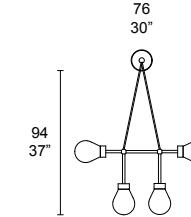

Art. 7383/3

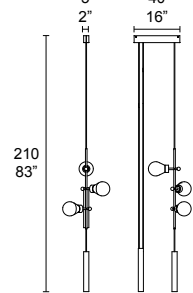

## MOONLIGHT

Lampada in metallo verniciato o trattamento galvanico con diffusore in PMMA  
Painted metal lamp or galvanic treatment with PMMA diffuser

Struttura / Frame

● V0199  
Nero opaco  
Matt black

● V2805  
Ottone satinato  
Satin brass

Diffusore / Diffuser

○ Bianco Opale  
Ice White

Illuminazione / light source

STRIP LED 3000°K 24V  
(Ø33x6W) • (Ø40x9W)



Dimmerabile con convertitore DALI su richiesta  
Dimmable with DALI converter on request



Utilizzo da interno  
Indoor use



Prodotto dimmerabile  
Dimmable



Tensione d'uso  
Voltage



Modulo LED integrato sostituibile  
Integrated replaceable LED module



## M.MM

## MYA POP

Lampada in metallo e vetro Murano incamiciato  
Metal and "Incamiciato" Murano glass lamp

Struttura / Frame

○ V2907  
Bianco Opaco  
Matt white

Diffusore / Diffuser

● Vetro soffiato  
Rosso Olanda  
Holland Red  
Blown glass

● Vetro soffiato  
Azzurro Vacanze  
Holiday Blue  
Blown glass

○ Vetro soffiato  
Bianco latte  
Milky White  
Blown glass

Illuminazione / light source

LED 10W E14



Dimmerabile con convertitore DALI su richiesta  
Dimmable with DALI converter on request



Utilizzo da interno  
Indoor use



Prodotto dimmerabile  
Dimmable

Lampadina non compresa / Bulb not included.

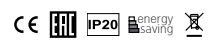

Art. 7327/1 Ø33

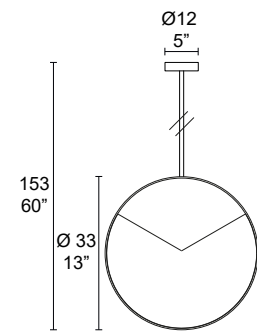

Art. 7327/1 Ø40

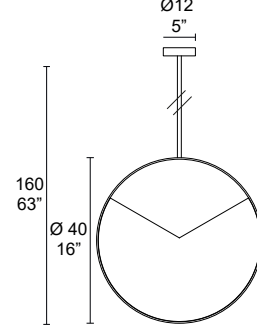

Art. 7327/2

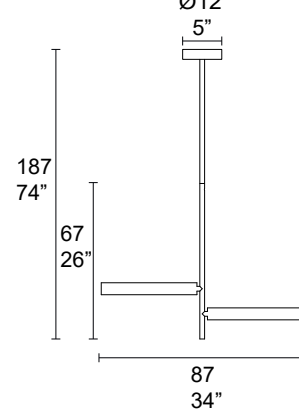

Art. 7327/A1 Ø33

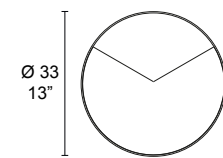

Art. 7327/A1 Ø40

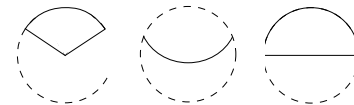
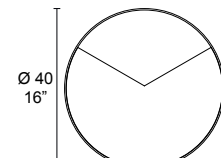

Maschere disponibili  
Available masks  
Ø 40 / Ø 33

Art. 7415/1

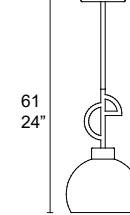

Art. 7415/3

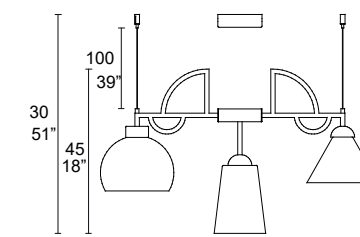

Art. 7415/8

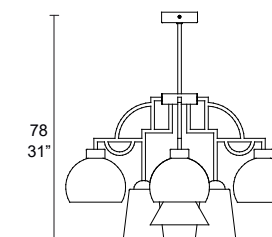

Art. 7415/16

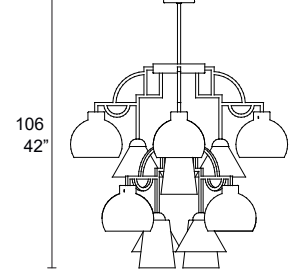

Art. 7415/A1

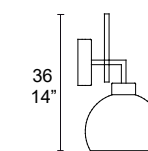

## PAPILLON

Lampada in metallo verniciato o trattamento galvanico con diffusore in vetro borosilicato  
Painted metal lamp or galvanic treatment with borosilicate glass diffuser

Struttura / Frame

V0199  
Nero opaco  
Matt black

V0216  
Ottone lucido  
Glossy brass

Diffusore / Diffuser

Bianco  
White

Su richiesta / On request

Ambra  
Amber

Fumè  
Fumè

Illuminazione / light source

5W G9

Dimmerabile con convertitore DALI su richiesta  
Dimmable with DALI converter on request

Utilizzo da interno  
Indoor use

Prodotto dimmerabile  
Dimmable

Lampadina non compresa / Bulb not included.



Art. 7207/8

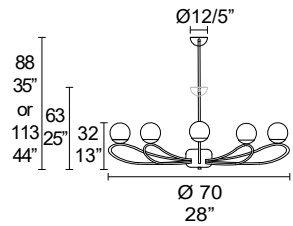

Art. 7207/12 Ø90

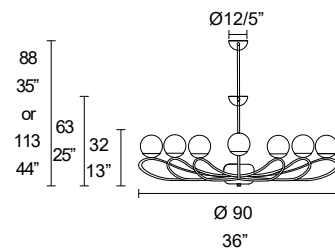

Art. 7207/12 Ø120

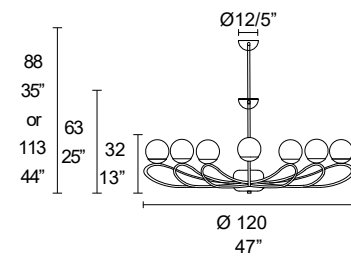

Art. 7207/36

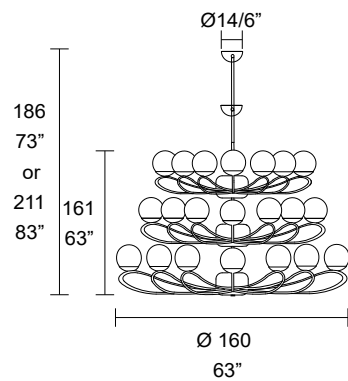

## M.MM

## PARAMOUNT

Lampada in metallo verniciato o trattamento galvanico  
Painted metal lamp or galvanic treatment

Struttura / Frame

V2905  
ottone ossidato  
dettagli nero opaco  
burnished brass  
matt black details

V2906  
nero opaco  
dettagli ottone ossidato  
matt black  
burnished brass details

Diffusore / Diffuser

Illuminazione / light source

10W E27 Filament vintage Ø125

8W E27 Filament vintage Ø95

Dimmerabile con convertitore DALI su richiesta  
Dimmable with DALI converter on request

Utilizzo da interno  
Indoor use

Prodotto dimmerabile  
Dimmable

Lampadina compresa / Bulb included.

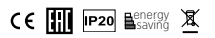

Art. 7382/LT2

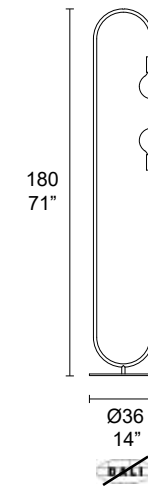

Art. 7382/L2

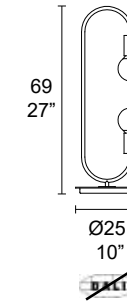

## PINEAPPLE

Lampada in ceramica con diffusore in vetro di Murano soffiato  
Ceramic lamp with Murano blown glass diffuser

Base / Base

- Base grigio RAL 7044  
Silk grey base RAL 7044
- Base gialla RAL 1004  
Golden yellow base RAL 1004
- Base nero RAL 9005  
Black base Ral 9005
- Base blu verdastro RAL 5001  
Green blue base RAL 5001
- Base turchese pastello RAL 6034  
Turquoise base RAL 6034

Diffusore / Diffuser

- tabacco  
Tobacco
- Bianco latte  
Milky White

Struttura / Frame

- V1607  
Parti metalliche cromo lucido  
Metal parts glossy chrome

Illuminazione / light source

- 20W E27
- Dimmerabile con convertitore DALI su richiesta  
Dimmable with DALI converter on request
- Utilizzo da interno  
Indoor use
- Prodotto dimmerabile  
Dimmable

Lampadina non compresa / Bulb not included.



## M.MM

## RAIN

Lampada in metallo verniciato o trattamento galvanico con diffusore in vetro borosilicato  
Painted metal lamp or galvanic treatment with borosilicate glass diffuser

Struttura / Frame

- V0199  
Nero opaco  
Matt black

Diffusore / Diffuser

- Trasparente  
Transparent
- Fumé metallico  
Fumé metallic
- Satinato  
Frosted

Illuminazione / light source

- 10W LED E14 Classic P45
- Dimmerabile con convertitore DALI su richiesta  
Dimmable with DALI converter on request
- Utilizzo da interno  
Indoor use
- Prodotto dimmerabile  
Dimmable

Lampadina non compresa / Bulb not included.

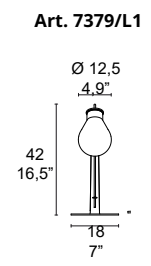
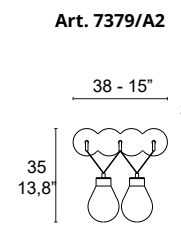
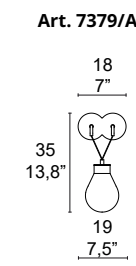
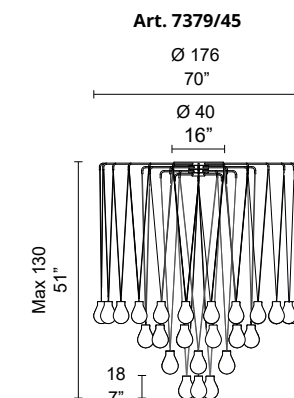
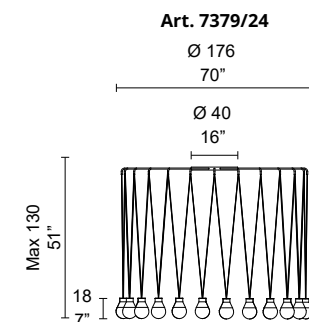
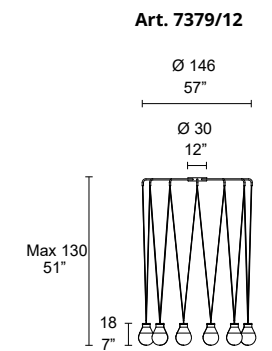
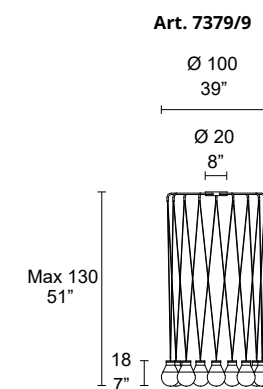
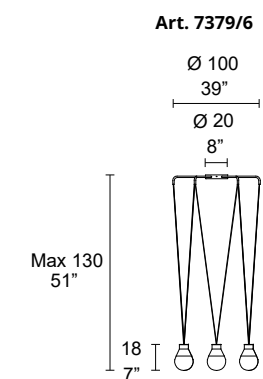
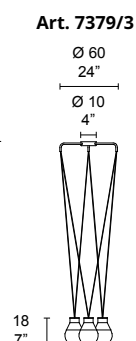
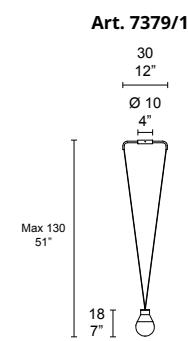
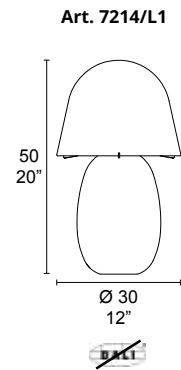
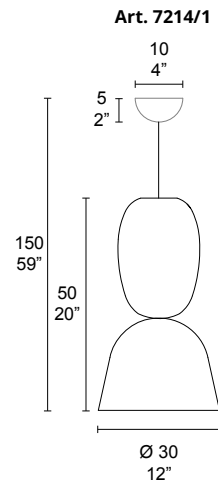
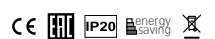

## RIPPLE

Lampada in metallo e vetro soffiato di Murano  
Lamp in metal and blown Murano glass

Struttura / Frame

V2946  
Brunito verniciato  
Painted burnished

Diffusore / Diffuser

Bianco latte  
Milky white

Illuminazione / light source

LED BOARD 10W 3000°K 220V/240V

LED 10W E14 Lampadina non compresa / Bulb not included.

 Dimmerabile con convertitore DALI su richiesta  
Dimmable with DALI converter on request

 Utilizzo da interno  
Indoor use

 Prodotto dimmerabile  
Dimmable

 Tensione d'uso  
Voltage

 Modulo LED integrato sostituibile  
Integrated replaceable LED module



Art. 7399/1  
Art. 7399/3

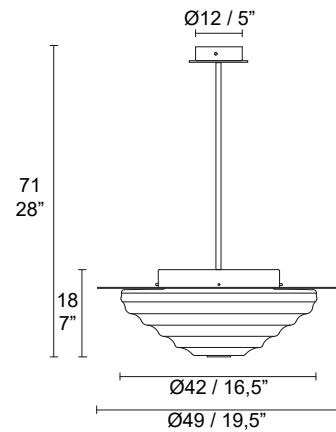

Art. 7399/P1  
Art. 7399/P3

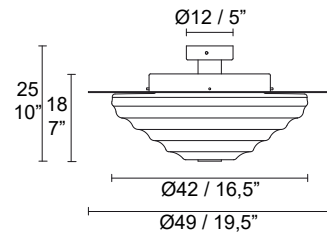

## M.MM

## TILTIT

Lampada in metallo e vetro borosilicato  
Metal and borosilicate glass lamp

Struttura / Frame

V2907  
bianco opaco  
Matt white

V0216  
ottone lucido  
glossy brass

Diffusore / Diffuser

bianco con vetro  
rosso frutta  
white with fruit  
red glass

bianco con vetro  
verde Douglas  
white with Douglas  
green glass

bianco con vetro  
marrone muschio  
white with moss  
brown glass

Illuminazione / light source

5W G9 solo diffusore bianco  
only the white diffuser

 Utilizzo da interno  
Indoor use

 Prodotto dimmerabile  
Dimmable

Lampadina non compresa / Bulb not included.

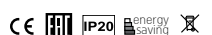

Art. 7412/L1

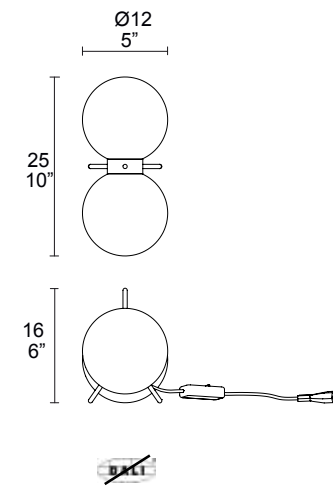

## TRIGON

Lampada in metallo galvanico e vetro soffiato  
Metal lamp galvanic treatment and blown glass

Struttura / Frame

- V 2833  
Nickel nero  
Black nickel

Diffusore / Diffuser

- Vetro soffiato  
cristallo satinato  
satin crystal blown  
glass

Illuminazione / light source

LED BOARD 10W 3000°K 220V/240V

 Dimmerabile con convertitore DALI su richiesta  
Dimmable with DALI converter on request

 Utilizzo da interno  
Indoor use

 Prodotto dimmerabile  
Dimmable

 Tensione d'uso  
Voltage

 Modulo LED integrato sostituibile  
Integrated replaceable LED module



Art. 7424/1

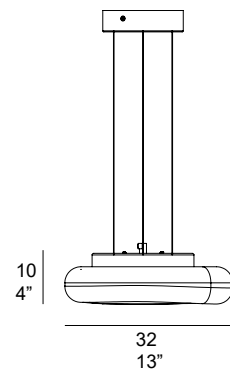

## M.MM

## WHALE

Lampada in metallo verniciato o trattamento galvanico con diffusore in PMMA  
Painted metal lamp or galvanic treatment with PMMA diffuser

Struttura / Frame

- V2907  
Bianco opaco  
Matt white

- V2910  
Vernice oro opaco e parti  
ottone lucido  
Opaque gold color with  
glossy brass parts

Diffusore / Diffuser

- Bianco opale  
Ice white

Illuminazione / light source

   STRIP LED 45W 3000°K 3800lm

 Dimmerabile con convertitore DALI su richiesta  
Dimmable with DALI converter on request

 Utilizzo da interno  
Indoor use

 Prodotto dimmerabile  
Dimmable

 Tensione d'uso  
Voltage

 Modulo LED integrato sostituibile  
Integrated replaceable LED module

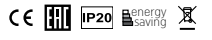

Art. 7378/1

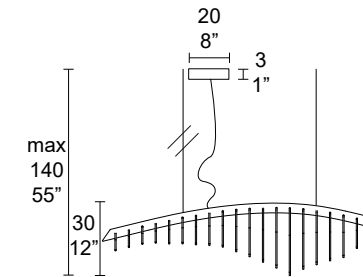

Certifications



Prodotto conforme ai requisiti essenziali per la commercializzazione ed utilizzo nell'Unione Europea.  
Product in compliance with the essential requirements for the marketing and use in the European Union.



Prodotto conforme a tutte le normative tecniche delle procedure di valutazione dell'Unione doganale eurasiatica.  
Product complies with all technical regulations of the Eurasian Customs Union evaluation procedures.



Utilizzo da interno  
Indoor use



Utilizzo da esterno  
Outdoor use



Prodotto dimmerabile  
Dimmable



Lampadina non dimmerabile  
Non-Dimmable Bulb



Tensione d'uso  
Voltage



Tensione d'uso  
Voltage



Lampadina a LED sostituibile  
Replaceable LED bulb



Non protetto contro l'ingresso di liquidi  
Not protected against liquids permeation



Modulo LED integrato non sostituibile  
Integrated non-replaceable LED module



Modulo LED integrato sostituibile  
Integrated replaceable LED module



Da installare con foro per incasso  
Recessed installation



Prodotto orientabile  
Swiveling Product



Peso netto  
Net weight



Peso lordo  
Gross weight

Type	Lampadine led / Led bulbs	Watt
E14		10W
E27		20W
G9		5W
Gx53		8W
GU 10		15W



Lampadina dimmerabile. La compatibilità con i sistemi di dimmerazione è indicata nelle specifiche di ogni prodotto.  
Dimmable bulb. Compatibility with dimming systems is indicated in the specs of each product.



Lampadina non dimmerabile - Not Dimmable



**VISUAL DIRECTION AND STYLING**

GIORGIO BISCARO  
M.M. LAMPADARI

**SET DESIGN & STYLING**

**3D VISUALISATION**  
M.M. LAMPADARI  
LAURA POZZI  
MARILENA FRAGKOU  
STUDIO ROCCI  
BRUGER STUDIO

**PHOTOGRAPHY**

ASOLANAGROUP  
ANTONIO CAMPANELLA  
ALESSANDRO DI BON  
FEDERICO MARIN  
STUDIO ROCCI  
EMANUELE SURIAN

**COLOUR CALIBRATION**

GM STUDIO1

**THANKS TO**

AGAPE  
BOSA CERAMICHE  
DESALTO  
DEVON&DEVON  
KREOO  
MADE A MANO  
MARAZZI GROUP  
MATTEO PALA  
MATTEO ZORZENONI  
MAURO BOLOGNESI  
MINIFORMS  
MOLTENI & C  
MOROSO  
NODUS RUG  
TUBES  
SABA  
SCAPIN  
SONIA PEDRAZZINI

**THANKS FOR PHOTO TO**

ALTACORTE pg 74 - 165 - 181  
ARTELINEA pg 178  
B-LINE pg 82  
BE ARCHITETTURA pg 121  
CIERRE pg 87  
DOIMO CUCINE pg 72  
ELENA DESIGN PROJECT pg 66  
FIAM pg 88 - 111 - 112  
MODULNOVA pg 60  
SABA pg 85 - 107  
STUDIO MAJO pg 140 - 134  
STUDIO STEP pg 115  
MAISON ARABELLA pg 151

Tutti i prodotti MM Lampadari S.r.l. sono conformi alle direttive Europee in vigore. Ogni articolo prodotto presentato nel catalogo é realizzato e decorato artigianalmente, pertanto lievi differenze nelle dimensioni, nel colore o nei dettagli costituiranno il carattere di unicità proprio della lavorazione manuale.

*All MM Lampadari S.r.l. Products comply with the European directives in force.*

*Each product presented in the catalogue is produced and decorated by hand; therefore, slight colour, size or detail differences will make the unique character in the handwork.*

MM Lampadari S.r.l. si riserva il diritto di intervenire in qualunque momento e senza preavviso per apportare le modifiche che ritenesse più opportune per migliorare il prodotto o in risposta a qualsiasi esigenza di carattere normativo costruttivo o commerciale.

*MM Lampadari S.r.l. reserves its right to intervene in every moment and without forewarning in order to make the modifications more suitable to improve the product or reply to each legal, manufacturing or commercial requirement.*



© M.M. LAMPADARI. È vietata la riproduzione anche parziale di questo catalogo

© M.M. LAMPADARI. It is forbidden to reproduce any part of this catalogue

Riedizione Aprile 2025

Reissue April 2025



**mmlampadari**

Via Feltrina 37 , 31040 Pederobba (TV) Italy

Email: mmlampadari@mmlampadari.com Web: www.mmlampadari.com Tel. +39 0423 688800

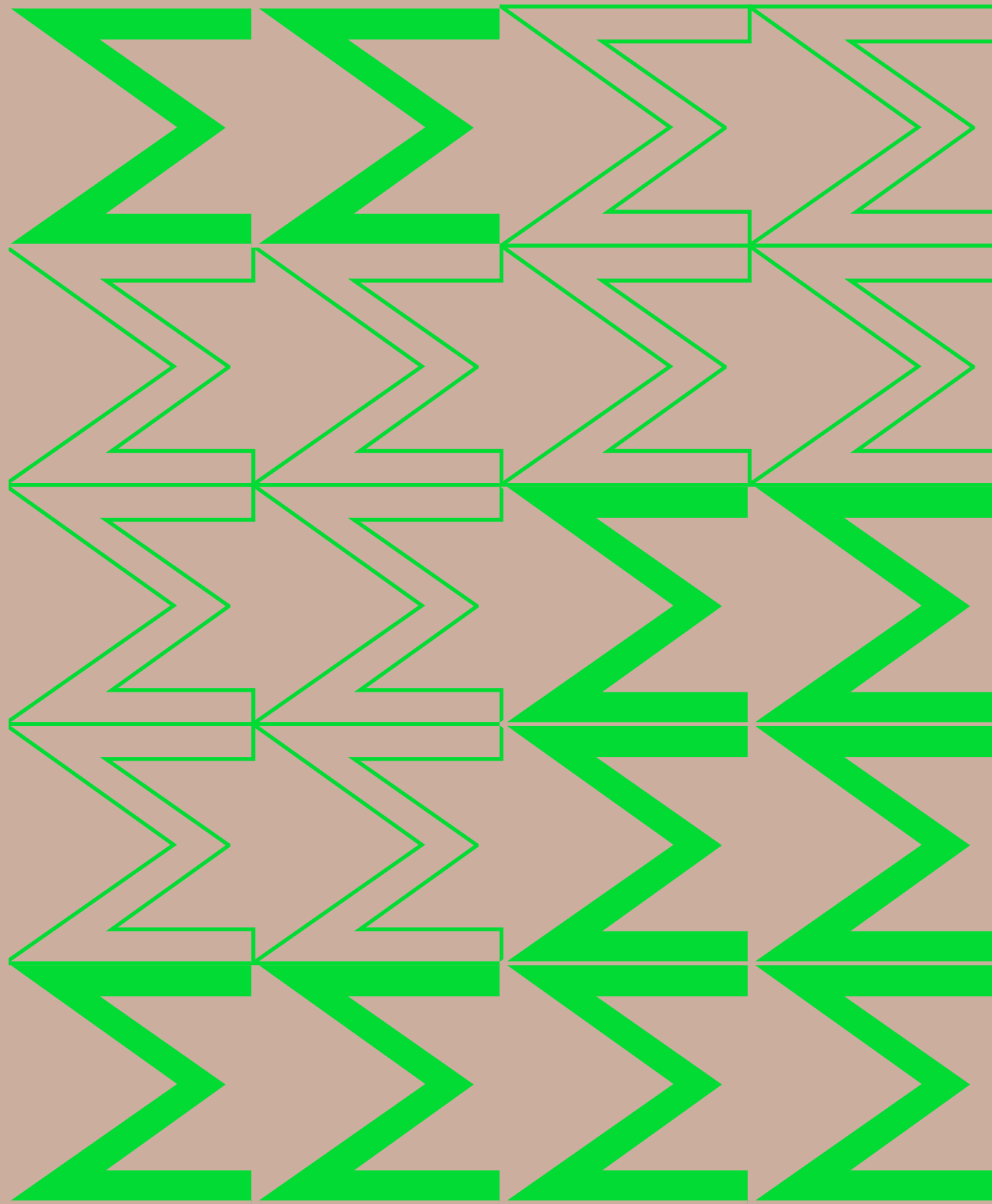



**mm**lampadari