



M1926

MANTELLASSI

COSMOPOLITAN

Collection

M1926

MANTELLASSI



Collection

COSMOPOLITAN

Perché Cosmopolitan?

Da quasi un secolo Mantellassi ha uno scopo: creare e produrre oggetti che rendano la vostra casa il posto più accogliente del mondo.

Per questa ragione usiamo materiali preziosi e ricercati, adattiamo le nostre creazioni alle vostre esigenze e vi proponiamo nuove soluzioni per personalizzare il vostro stile. Questa collezione è nata per ispirare tutti coloro che ogni giorno si fermano ad apprezzare la bellezza di un particolare o la cura di una finitura pregiata.

Oggetti senza tempo per case che si aprono al mondo.

Why is it Cosmopolitan?

For almost a century Mantellassi has had a purpose: to create and produce objects that make your home the most welcoming place in the world.

For this reason we use precious and refined materials, we adapt our creations to your needs and we propose new solutions to customize your style. This collection was created to inspire all those who every day stop to appreciate the beauty of a particular or the care of a fine finish.

Timeless objects for houses that open up to the world.

Made in *Tuscany*

Sebbene si tratti di una collezione cosmopolita è altrettanto vero che Mantellassi ha una storia e delle radici che sono indissolubilmente legate alla propria terra di origine: la Toscana.

A questo punto sarebbe facile citare tutti gli artisti che nel corso degli anni hanno arricchito con le proprie opere le città di tutto il mondo ma noi vogliamo ricordare l'eredità di milioni di artigiani, che da secoli hanno racchiuso nelle loro opere la bellezza che i paesaggi che ci circondano ogni giorno ci offrono.

La qualità del made in Italy con la creatività unica del made in Tuscany.

Although it is a cosmopolitan collection it is equally true that Mantellassi has a history and roots that are inextricably linked to its homeland: Tuscany.

At this point it would be easy to mention all the artists who over the years have enriched cities around the world with their works but we want to remember the legacy of millions of artisans, that for centuries have enclosed in their works the beauty that the landscapes that surround us every day offer us.

The quality of Made in Italy with the unique creativity of Made in Tuscany.

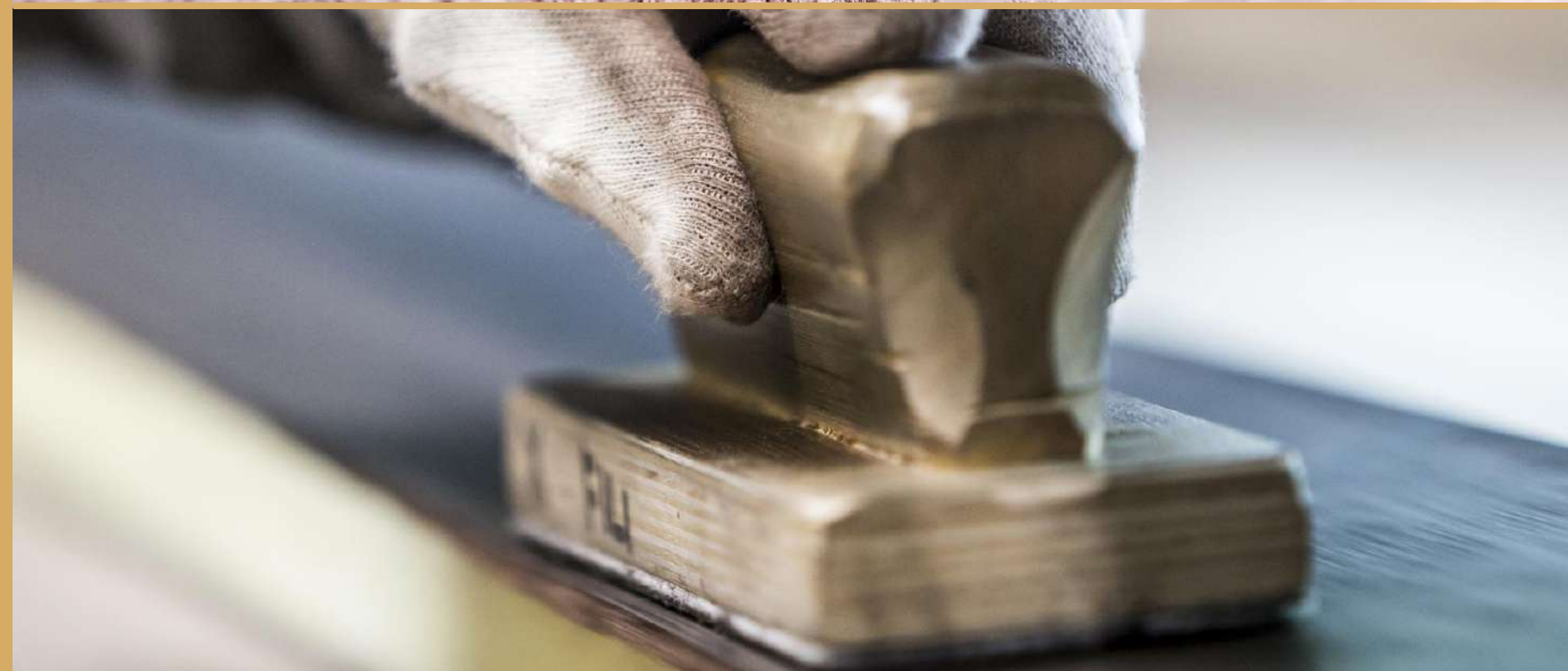



La cura dei nostri *Materiali*

Da Mantellassi quando concepiamo un nuovo oggetto, che sia una lampada o una poltrona, partiamo dall'effetto che vogliamo che questo abbia in coloro che lo osservano e lo toccano. Ed è proprio a questi sensi che si rivolgono le nostre prime attenzioni.





Per questa ragione i materiali che compongono i nostri prodotti devono essere di alta qualità e abbinati con gusto, in modo che questa sensazione si estenda a tutto l'oggetto, conferendogli quel carattere unico che hanno solo i prodotti fatti per resistere alle mode e durare nel tempo.

From Mantellassi when we conceive a new object, be it a lamp or an armchair, we start from the effect that we want this to have in those who observe and touch it. And it is to these senses that our first attention is directed.



For this reason the materials that make up our products must be of high quality and tastefully matched, so that this feeling extends to the whole object, giving it that unique character that only have products made to resist fashions and last over time.

Indice per categoria / Index by category

Divani / Sofas





Fedro	pag. 222-224	
Grand Tour	pag. 14-29	
Isidoro	pag. 78-85	
La Perla	pag. 176-178	
Nuvola	pag. 196-198	
Ola	pag. 118-121	
Bon Voyage	pag. 244-247	
Adone	pag. 38-43	
Pouff		
La perla	pag. 182	
Ola	pag. 138-139	
Fedro	pag. 218-219	

Cassettoni / Dressers





Ercole	pag. 64-67	
Ola Settimino	pag. 144-145	
Gessato	pag. 112	

Mantellassi / Cosmopolitan

Poltrone / Armchairs











Agostina	pag. 68-73	
Barrel	pag. 86-87	
La Perla	pag. 179-180	
Nuvola	pag. 199	
Over	pag. 200-202	
Vanesio	pag. 206-208	
Tango	pag. 248-249	
Souvenir	pag. 162-163	
Katrine	pag. 172-173	

Sedie / Chairs



Michelangelo	pag. 236-237	
Pontecorvo	pag. 256-259	
Vanesio	pag. 210-212	
Pheasant	pag. 218-219	

Indice per categoria / Index by category





Letti / Beds

Aurora	pag. 104-109	
Lady D	pag. 188-189	
Ola	pag. 132-135	
Romeo	pag. 54-59	
Fedro	pag. 164-167	
Buffet		
Blaze	pag. 238	
Ermes	pag. 264-267	
Mimosa	pag. 92-97	
Peacock	pag. 168-169	
Vanesio	pag. 204-205	





Applique e Lampade da parete / Wall lamp

Le Fate	pag. 98-103	
Chiaraluna	pag. 182-185	
Violante	pag. 52-53	





Comodini / Bed Side Table

Ercolino	pag. 60-63	
Ola	pag. 136-137	
Peacock	pag. 170-171	
Gessato	pag. 104	

Toilette e Specchi / Toilette and Mirrors

Ola	pag. 140-143	
Peacock	pag. 158-159	
Peacock	pag. 160-161	
Gioconda	pag. 110-111	
Shanghai	pag. 15	

Bar e Vetrine / Showcase





Blaze	pag. 234	
Martini	pag. 228-229	
Vanesio	pag. 213	
Ermes	pag. 216-217	

Indice per categoria / Index by category

Porta Tv / *Tv Holder*

Blaze	pag. 253-254	
Ercole	pag. 44-47	
Peacock	pag. 152-155	
Nuvola	pag. 204-205	
Gillo	pag. 225	



Consolle

Arco	pag. 181	
Mimosa	pag. 88-91	
Shanghai	pag. 15	
Vanesio	pag. 209	
Liu	pag. 230-233	



Libreria / *Bookcase*

Grace	pag. 146	
-------	----------	---







Tavolo da pranzo / *Dining Table*

Vanesio	pag. 214-215	
Pontecorvo	pag. 260-263	
Scultura	pag. 234-235	

Dormeuse and Bench

Aston	pag. 77	
La Perla	pag. 190-191	

Tavolino / *Side Table*

Cono	pag. 14-15	
Scarlett	pag. 48-51	
Scricciolo	pag. 74-75	
Globo	pag. 172	
Ola	pag. 124-125	
Plettro	pag. 14-15	

Tavolo da salotto / *Coffee Table*

Skyline	pag. 30-33	
Saturno	pag. 34-37	
Scarlett	pag. 240-241	
Ola	pag. 125-129	
Cubo	pag. 150-151	
Peacock	pag. 156-157	
Nuvola	pag. 203	
Zaza	pag. 218-219	

Mantellassi / *Cosmopolitan*

Collection
COSMOPOLITAN



The *world* of Cosmopolitan

- Miami *gold* pag. 14-75
- Miami *ocean* pag. 76-115
- New York *urban* pag. 116-147
- New York *brooklyn* pag. 148-173
- Londra *royal* pag. 174-193
- Londra *sky* pag. 194-220
- Parigi *nouvelle* pag. 221-241
- Parigi *boulevard* pag. 242-261





Miami *gold*



Miami è principalmente due cose. Le sue spiagge dorate e il suo mare azzurro.

Partiamo quindi dalle spiagge dorate della Gold Coast che hanno ispirato la nostra collezione e che ritroviamo nei colori delle finiture o nelle textures delle nostre creazioni.

*Miami is mainly two things.
Its golden beaches and its
blue sea.*

*Let's start from the golden
beaches of the Gold Coast
that inspired our collection
and that we find in the colors
of the finishes or textures of
our creations.*

Grand Tour

Divano / Sofa



Un divano componibile e moderno,
in cui modularità e tecnologia si
uniscono al servizio del relax e del
benessere.

*A modular and modern sofa, in
which modularity and technology
are combined with the service of
relaxation and well-being.*

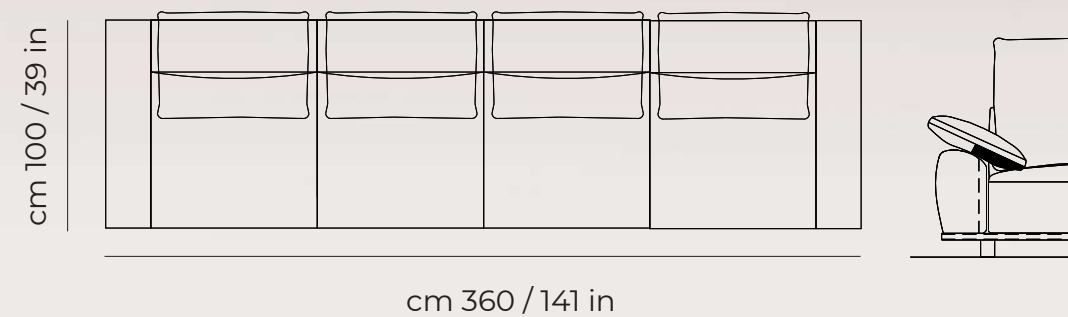





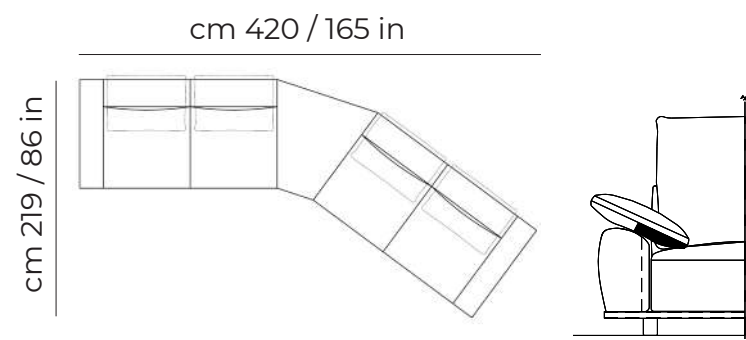
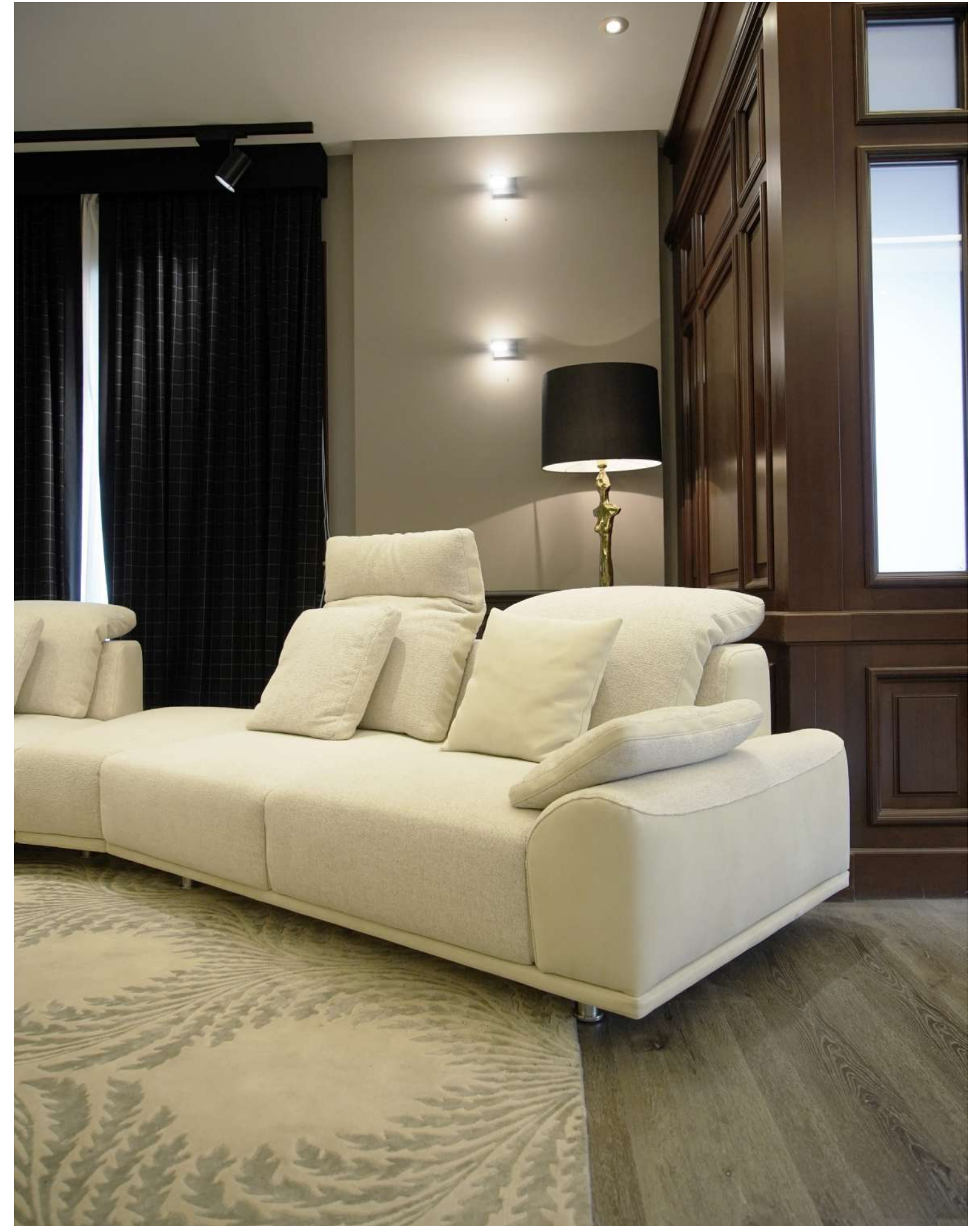

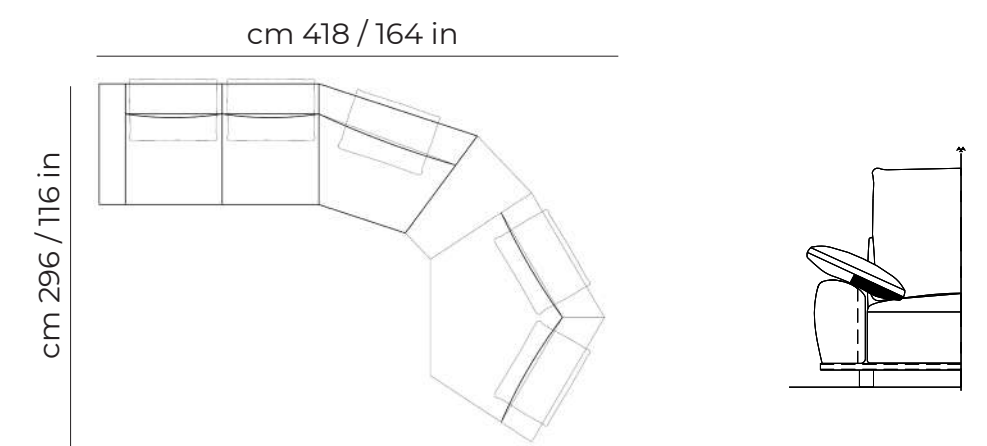
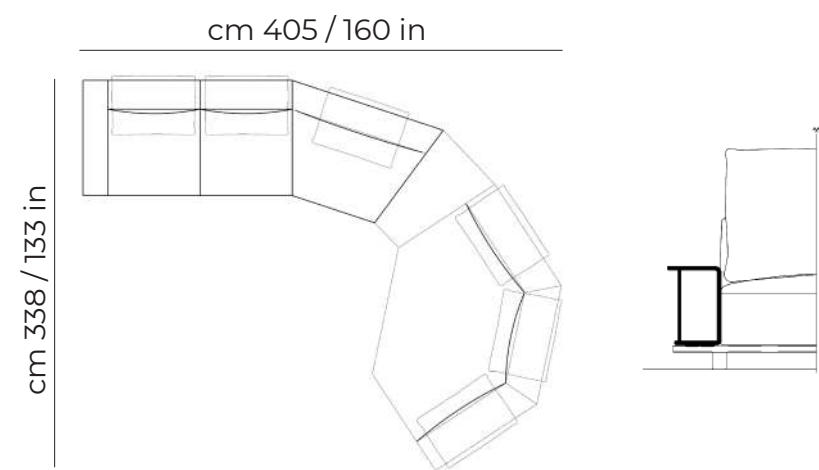

Skyline

Tavolo da salotto / *Coffee Table*





Piano rettangolare in mdf
impiallacciato eucalipto
termotrattato. Piano superiore ovale
realizzato in mdf e rivestito in cuoio
testa di moro. Struttura in ottone
brunito.

*Rectangular top in thermo-treated
eucalyptus veneered mdf.
Oval top made of mdf and covered
in dark brown leather. Structure in
burnished brass.*

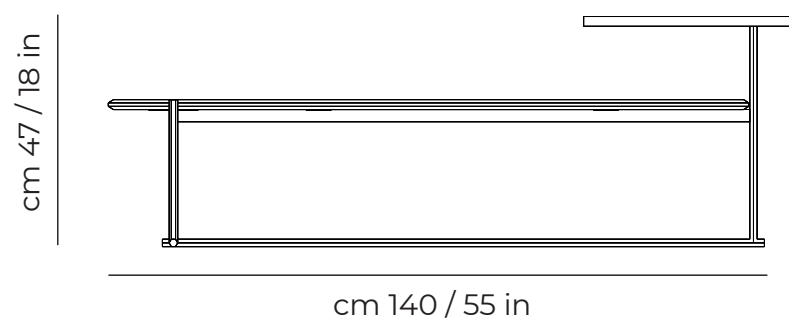
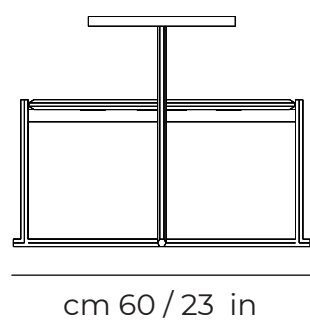

Saturno

Tavolo da salotto / *Coffee Table*





La struttura portante in legno, rigida, è stata esaltata nella sua essenza coprendola con una vernice craquelé bronzo: nel sotto-piano e nei laterali. Il piano di appoggio è coperto da una impiallacciatura pre-composta a spina di pesce.

The wooden structure, rigid, has been enhanced in its essence by covering it with a craquelé bronze paint: in the sub-floor and in the sides. The table top is covered with a pre-composed herringbone veneer.

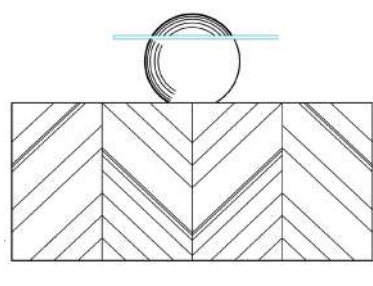
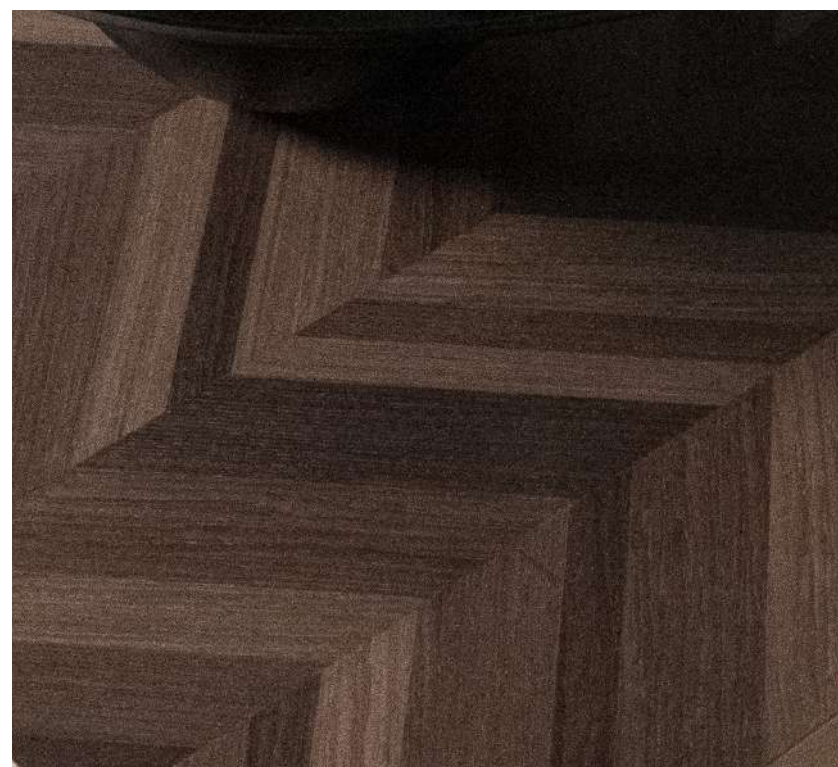

cm 60 / 31 in

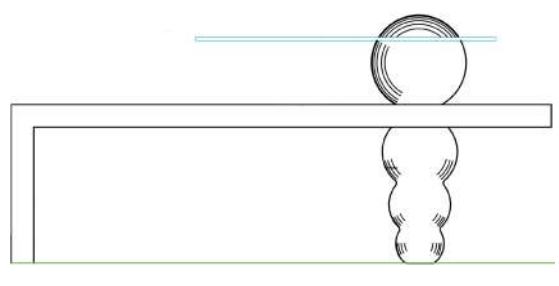

cm 120 / 47 in

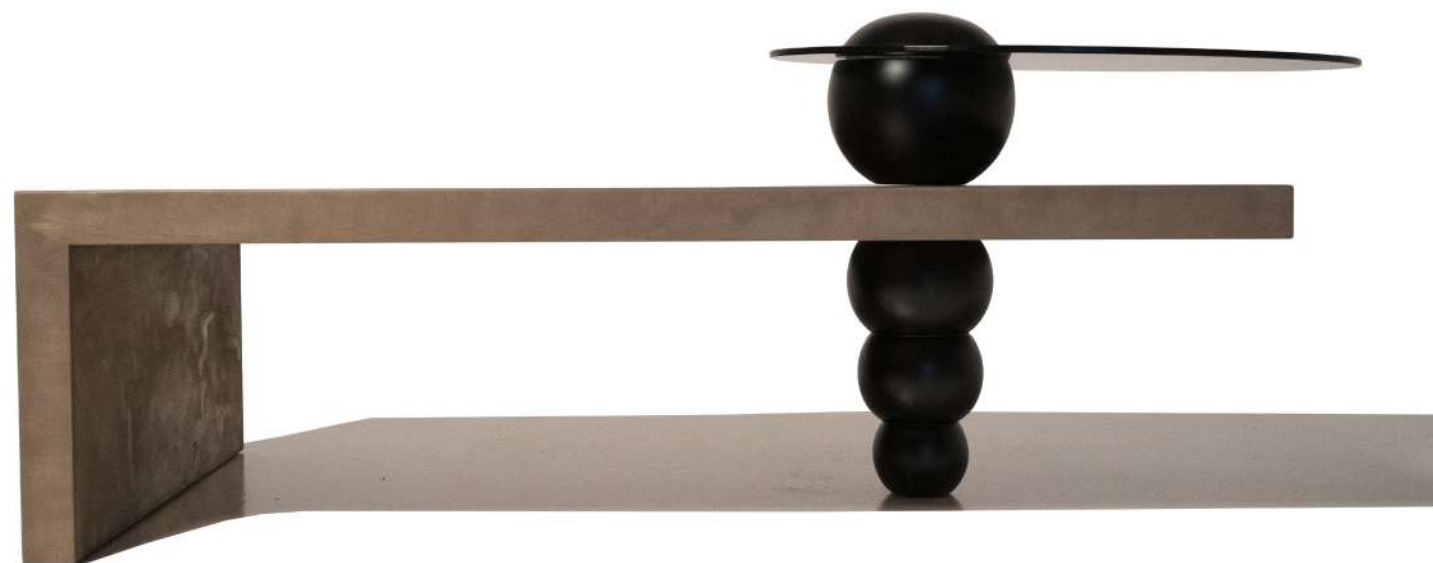

Adone

Divano / Sofa







Bracciolo alto e metà spalliera: pelle art. Nuvola col. Marrone cat.800; Seduta, metà bracciolo basso e metà spalliera bassa: pelle art. Perlato col. segale cat.950; Mobiletto ad angolo in noce canaletto con cornice in ottone satinato con cassetto e maniglia personalizzata M1926.

High armrest and half backrest: leather art. Nuvola col. Brown cat.800; Seat, half low armrest and half low backrest: leather art. Perlato col. rye cat.950; Corner cabinet in canaletto walnut with satin brass frame with drawer and custom handle M1926.

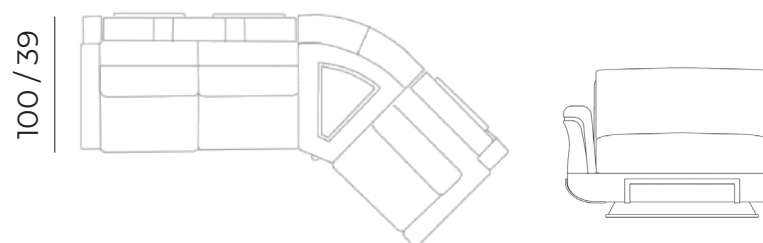

100 / 39

cm 470 / 185 in



Ercole

Porta Tv / Tv Holder





Struttura impiallacciata in eucalipto termotrattato, finitura trasparente opaco. Piano in vetro laccato scuro, impreziosito da maniglie e piedini in ottone brunito. L'interno di ogni cassetto è rivestito in vero cuoio.

Structure veneered in thermo-treated eucalyptus, matt transparent finish. Top in dark lacquered glass, embellished with burnished brass handles and feet.

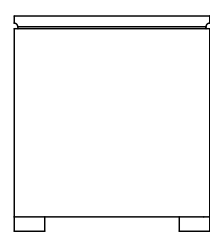

cm 55 / 23 in

cm 60 / 23 in

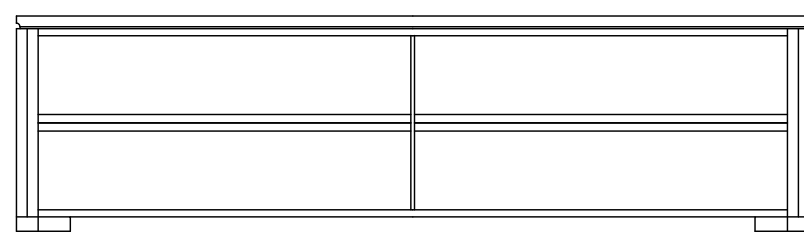

cm 221 / 87 in



Scarlett

Tavolino / *Side Table*





Tavolino da salotto con piano circolare, il quale può essere rivestito in vari materiali. La forma audace si coniuga ad uno stile raffinato che lo rende protagonista dell'ambiente. La finitura della base può essere in diverse finiture: ottone brunito, cromato, foglia acidata o laccato.

Coffee table with circular top, which can be covered in various materials. The bold shape is combined with a refined style that makes it the protagonist of the environment. The finish of the base can be in different finishes: burnished brass, chrome, etched leaf or lacquered

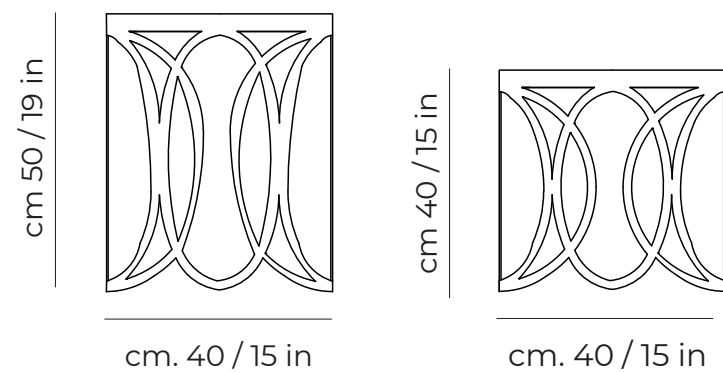

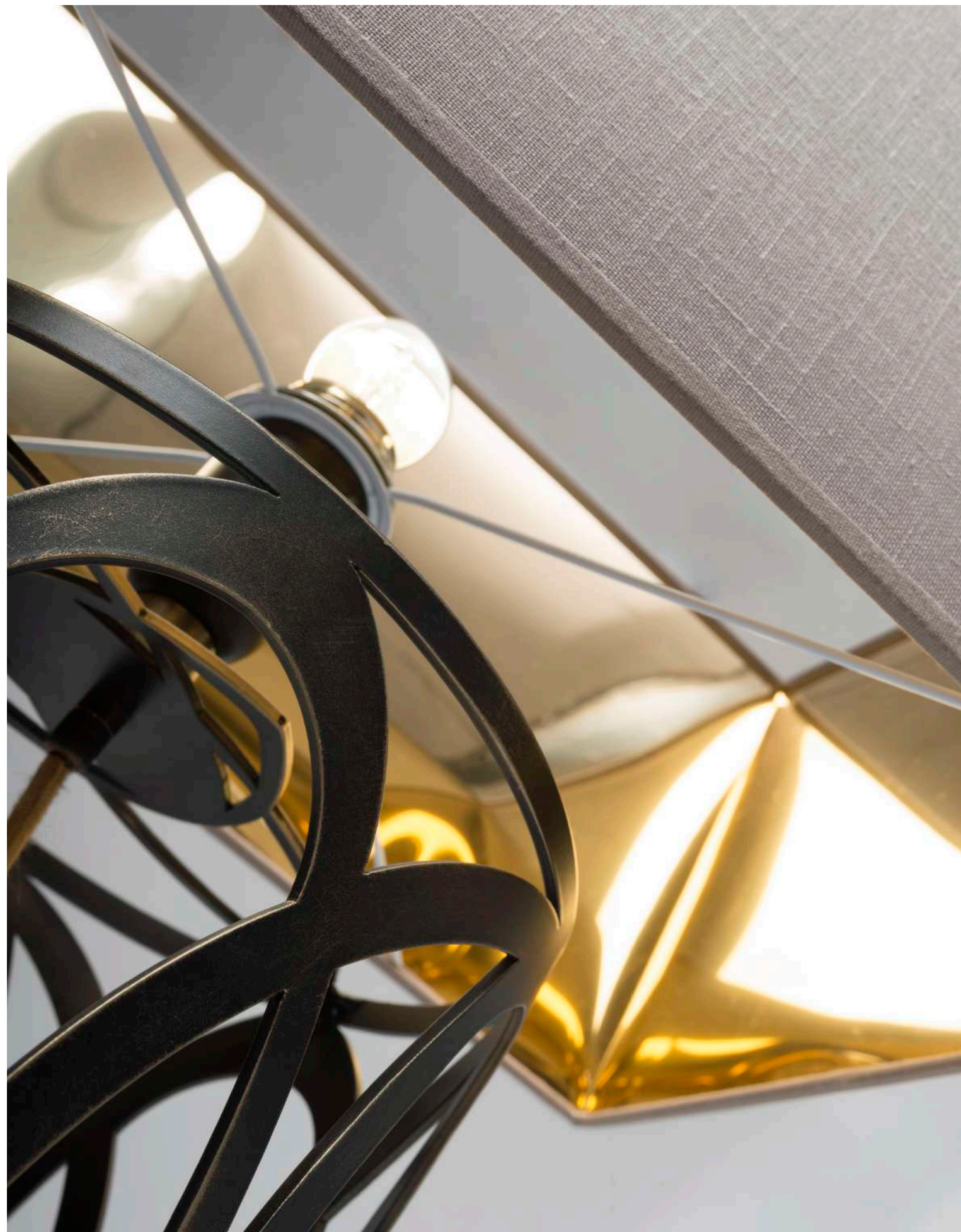

Mantellassi / *Cosmopolitan*

Violante

Lampada da tavolo / *Table Lamp*

Elegante lampada da tavolo con raffinato paralume in tessuto, struttura in ottone brunito e basamento in rovere tinto noce.

Elegant table lamp with refined fabric lampshade, burnished brass structure and walnut stained oak base.

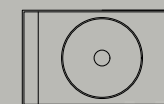

cm 75 / 29 in

cm 50 / 19 in





Romeo

Letto / Bed



Un prodotto con dettagli geometrici che prendono spunto dal linguaggio architettonico rinascimentale italiano. La testata presenta infatti una serie di elementi sfaccettati in rilievo come il bugnato esterno della facciata del Palazzo dei Diamanti a Ferrara. Ogni elemento può essere personalizzato e rivestito con materiali e colori abbinati che esaltano questo effetto tridimensionale. La cornice della testata è la base del sommier sono in ottone disponibile in varie finiture.

A product with geometric details inspired by the Italian Renaissance architectural language. The headboard has in fact a series of faceted elements in relief such as the external ashlar of the facade of the Palazzo dei Diamanti in Ferrara. Each element can be customized and covered with matching materials and colors that enhance this three-dimensional effect. The frame of the headboard is the base of the sommier are in brass available in various finishes.

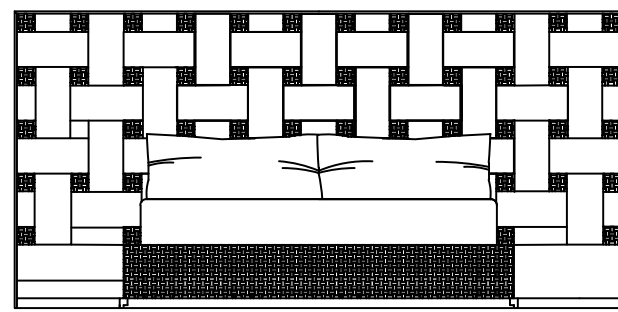

cm. 300 / 118 in

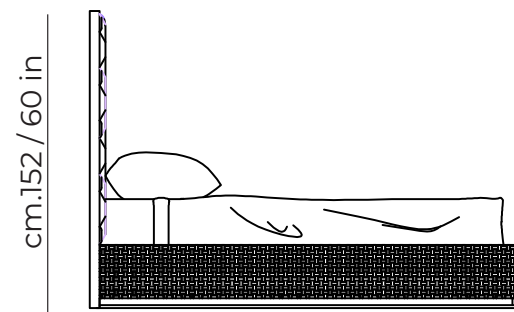

cm. 152 / 60 in

cm. 220 / 87 in



Ercolino

Comodino / *Bed Side Table*





Ercolino è un comodino dalla linea moderna e compatta. Impiallacciato foglia eucalipto, frisée termotrattato scuro, che ne esalta la tridimensionalità della venatura. La linea rigorosa è enfatizzata dalle maniglie e dai piedini in ottone brunito. L'interno dei cassetti è rivestito in vero cuoio.

Ercolino is a bedside table with a modern and compact line. Veneered eucalyptus leaf, frisée heat-treated dark, which enhances the three-dimensionality of the grain. The rigorous line is emphasized by the handles and feet in burnished brass. The inside of the drawers is covered in real leather.

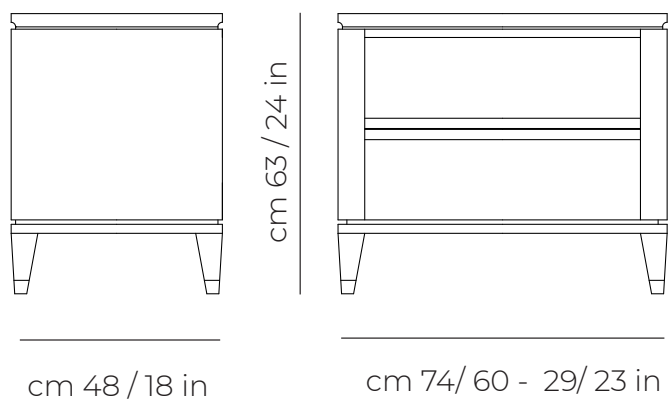

Ercole

Cassettone / Dresser





Struttura impiallacciata in Eucalipto frisée termotrattato
 Zampe, maniglie e profili in ottone brunito.
 Piano con inserto in vetro laccato;
 Bordo top e dettagli laccati
 Interno cassetti rivestito in Vero Cuio col. Cioccolato

*Structure veneered in thermo-treated Frisée Eucalyptus
 Legs, handles and profiles in burnished brass.
 Top with lacquered glass insert;
 Top edge and lacquered details
 Internal drawers covered in Vero Cuio col. Chocolate*

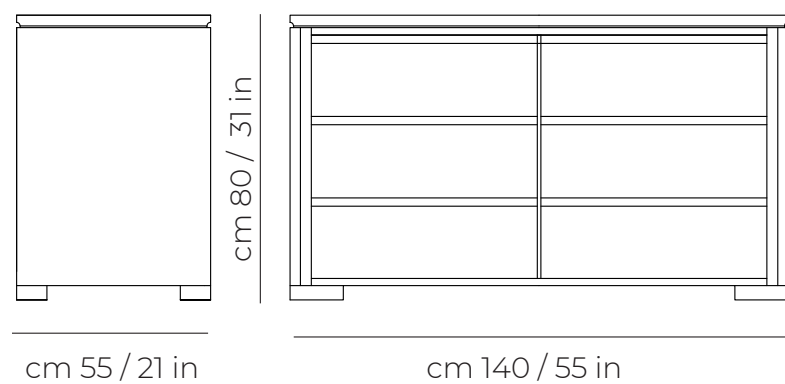

Agostina

Poltrona / Armchair





La nostra poltrona Agostina è rivestita in bouclé di cotone naturale con bordino a contrasto a definire l'armonia delle forme. La base in massello di faggio verniciato in mogano profilato ciliegio, viene caratterizzata dalle zampe in ottone brunito.

Our Agostina armchair is upholstered in natural cotton bouclé with contrasting piping to define the harmony of shapes. The base in solid beech painted mahogany profiled cherry, is characterized by the legs in burnished brass.

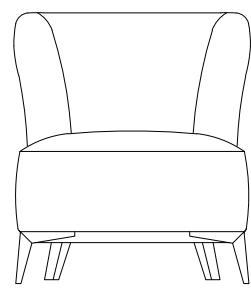

cm 64 / 25 in

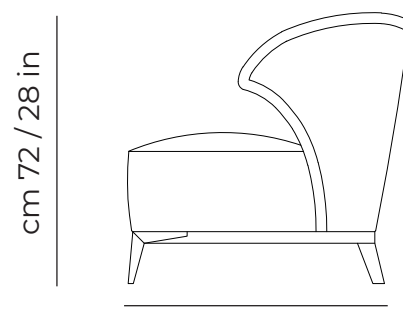

cm 72 / 28 in

cm 76 / 30 in







Scricciolo

Tavolino / Side Table

Tavolino con piano impiallacciato in radica di mirto, versatile nelle finiture può essere realizzato con il piano rivestito in cuoio con cuciture al vivo per definirne le forme. La base in metallo in questo caso è verniciata in una finitura nero micaceo.

Coffee table with veneered top in myrtle burl, versatile in finishes can be made with the top covered in leather with raw seams to define the shapes. The metal base in this case is painted in a micaceous black finish.

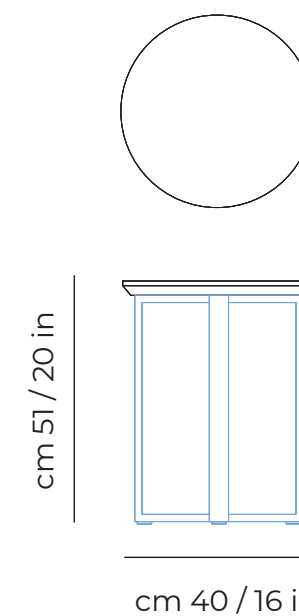

Miami ocean



Immaginate l'oceano davanti a voi. L'azzurro del mare che si estende a perdita d'occhio e si congiunge con il cielo all'orizzonte.

Questa è la sensazione che abbiamo voluto racchiudere nelle nostre creazioni. Morbide onde che si rincorrono e fiori leggeri trasportati dalla brezza, non importa dove vada il vostro pensiero, l'importante è lasciarlo libero di volare.

Imagine the ocean before you. The blue of the sea stretching as far as the eye can see and joining with the sky on the horizon. This is the feeling we wanted to enclose in our creations. Soft waves chasing each other and light flowers carried by the breeze, no matter where your thought goes, the important thing is to let it free to fly.



Isidoro

Divano / Sofa

cm 107 / 42 in

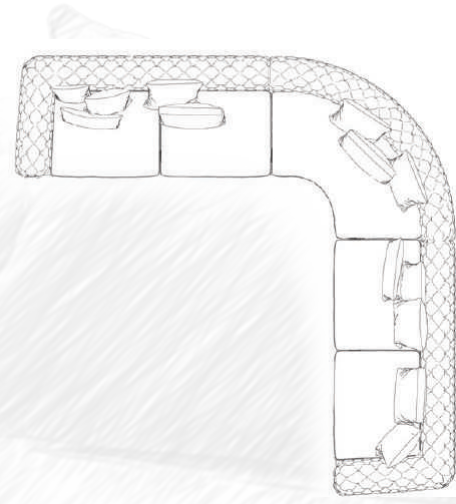

cm 390 / 153 in



cm 390 / 153 in







Il divano Isidoro è un'opera di tappezzeria di assoluto livello, totalmente realizzato in capitonné, con zampe verniciate in acciaio. Questo divano è ideale per essere posto come elemento centro stanza per poter ammirare la sua precisione e l'estrema cura della lavorazione.

Isidoro sofa is a work of upholstery of absolute level, totally made of capitonné, with legs painted in steel. This sofa is ideal to be placed as a room center element in order to admire its precision and extreme care of workmanship.

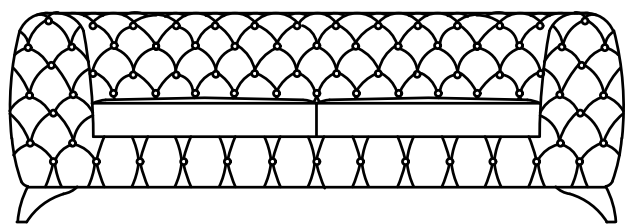

cm 220 / 86 in

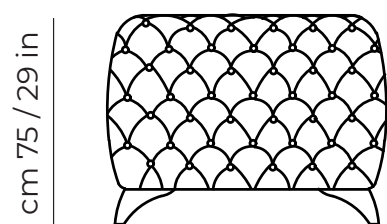

cm 100 / 39 in

cm 75 / 29 in





Barrel

Poltrona / Armchair

La base in metallo
finitura bronzo
conferisce alla
poltrona Barrel un
appeal decorativo
raffinato e di altro
pregio. Sofisticate
cuciture sottolineano
la silhouette curvilinea.

*The bronze finish
metal base gives the
Barrel armchair a
refined decorative
appeal and other
value. Sophisticated
seams emphasize
the curvilinear
silhouette.*

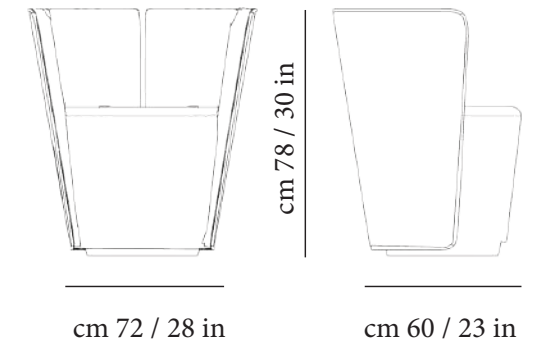



Mantellassi / *Cosmopolitan*

Mimosa

Consolle / *Consolle*

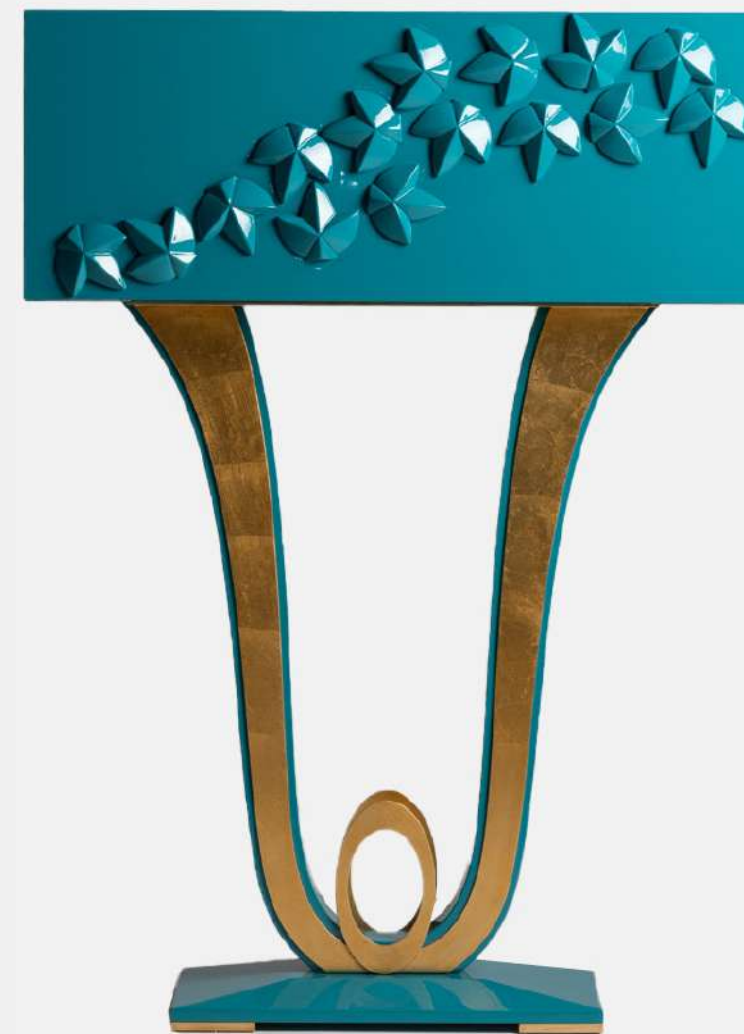

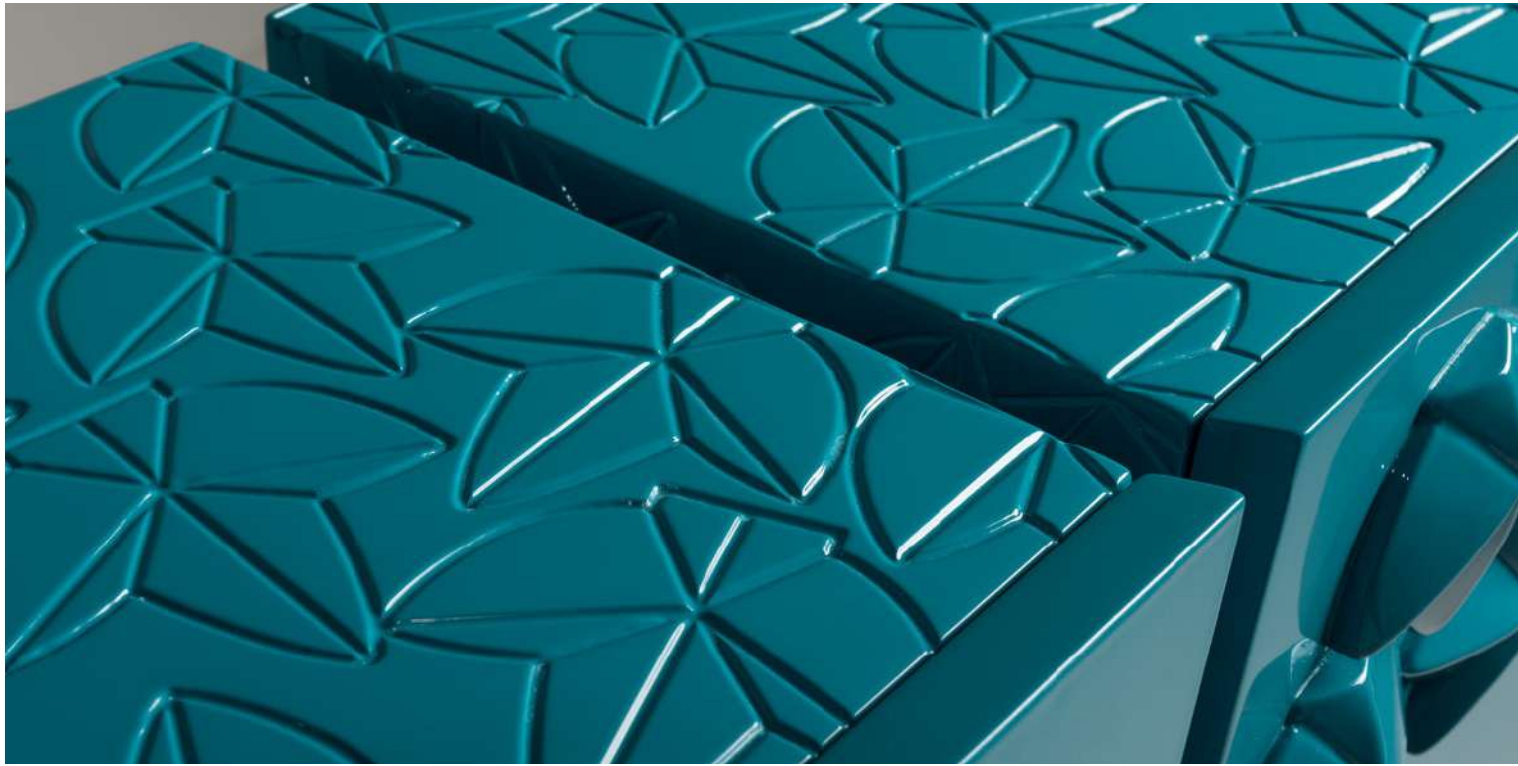

La preziosità delle forme dell'armadietto Mimosa si lega inevitabilmente alla bellezza delle finiture, come le laccature e la foglia oro o argento del profilo in metallo posto sull'arco. Il corpo superiore è decorato con elementi in rilievo simili a petali di fiore.

The preciousness of the shapes of the Mimosa cabinet is inevitably linked to the beauty of the finishes, such as the lacquers and the gold or silver leaf of the metal profile placed on the arch. The upper body is decorated with relief elements resembling flower petals.

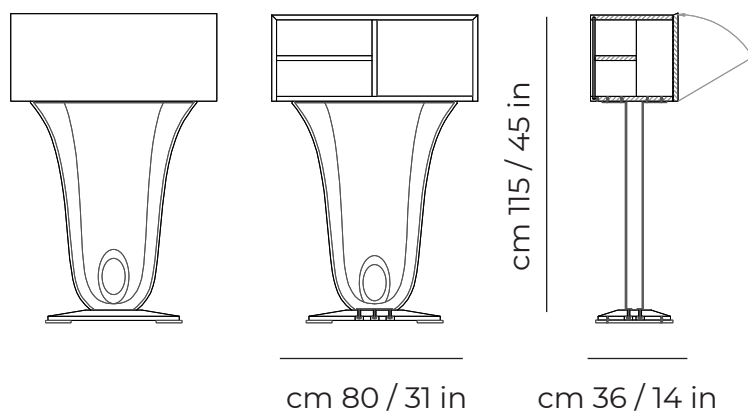



• *Mimosa Buffet*



Finitura top: impiallacciato foglia erable rosso,
 laccato lucido spazzolato;
 Finitura piani verticali e base: laccato lucido
 spazzolato;
 Finitura maniglia: foglia oro ossidata;
 Finitura profili metallo: laccato bronzo

*Top finish: erable red leaf veneer, brushed
 glossy lacquer;
 Vertical top and base finish: brushed glossy
 lacquer;
 Handle finish: oxidized gold leaf;
 Metal profiles finish: bronze lacquer*

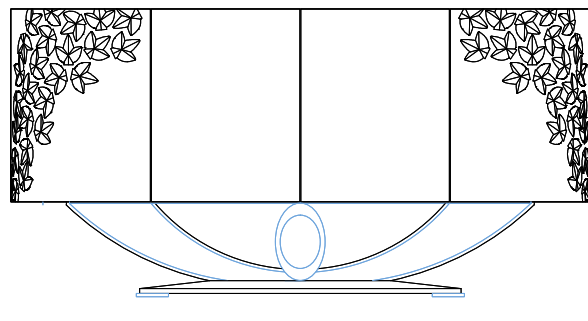

cm 179 / 70 in

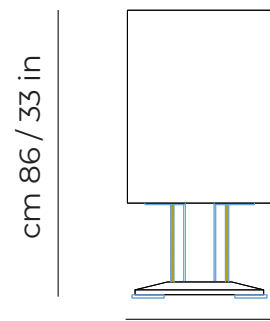

cm 86 / 33 in

cm 51 / 20 in







Le Fate

Applique

L'applique Le Fate è un complemento d'arredo stile neo liberty, costituito da grandi lampade a muro con boccioli di cristallo e foglie in metallo color bronzo, rame e oro.

The Le Fate wall lamp is a piece of furniture neo-liberty style, consisting of large wall lamps with crystal buds and leaves in bronze, copper and gold colored metal.



35 / 14

cm 112 / 44 in



15 / 6





◀ *Le Fate Composizione / Wall Lamp Composition*



cm 114 / 45 in



cm 108 / 43 in

cm 15 / 6 in



Aurora

Letto / Bed



Il letto Aurora è un prodotto dalle linee sobrie e gentili le quali si fondono ad una ricercata trapuntatura realizzata sia sulle fasce che sulla testata. La lavorazione è un disegno preciso e geometrico che genera un effetto rilievo su tutta la superficie dell'imbottitura del letto. La raffinata e sottile base in ottone lucido illumina il prodotto e fa da imposta al resto della struttura.

The Aurora bed is a product with sober and gentle lines that blend with a refined quilting made both on the bands and on the headboard. The workmanship is a precise and geometric design that generates a relief effect on the entire surface of the bed upholstery. The refined and thin polished brass base illuminates the product and acts as a shutter to the rest of the structure.

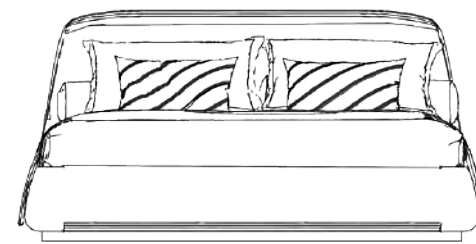

cm 200 / 79 in

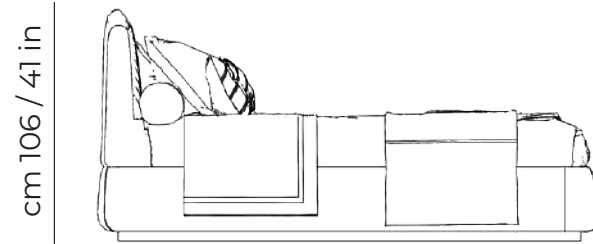

cm 106 / 41 in

cm 232 / 91 in





Gioconda

Specchio / Mirror

Specchiera elegante e raffinata. La lavorazione del legno a sezione convessa, arricchisce in modo distinto la tua parete. Le finiture, completamente personalizzate, potranno essere decise insieme.

Elegant and refined mirror. The woodwork with convex section, enriches your wall in a distinct way. The finishes, completely customized, can be decided together.

cm 90 / 35 in

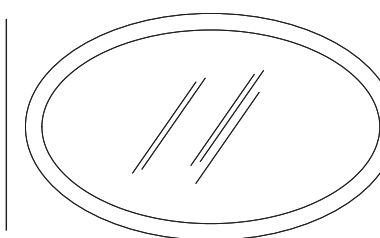

cm 160 / 63 in









New York *urban*



Pensate alla città cosmopolita per eccellenza...

Probabilmente state passeggiando in Central Park, respirando nel polmone verde di una delle metropoli cosmopolite per antonomasia. Oppure state ammirando i grattacieli lungo la Fifth Avenue. Questa collezione è ispirata a tutte queste sensazioni che abbiamo vissuto, magari anche attraverso una canzone o un film ma che rimangono nei nostri sogni in una sorta di memoria collettiva che questa città ha saputo creare nel corso degli anni.

Think of the cosmopolitan city par excellence...

You are probably walking in Central Park, breathing in the green lung of one of the cosmopolitan metropolises par excellence. Or you're admiring the skyscrapers along Fifth Avenue. This collection is inspired by all these feelings that we have experienced, maybe even through a song or a movie but that remain in our dreams in a sort of collective memory that this city has been able to create over the years.

Ola

Divano / Sofa



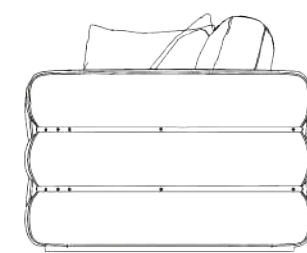

cm 100 / 39 in

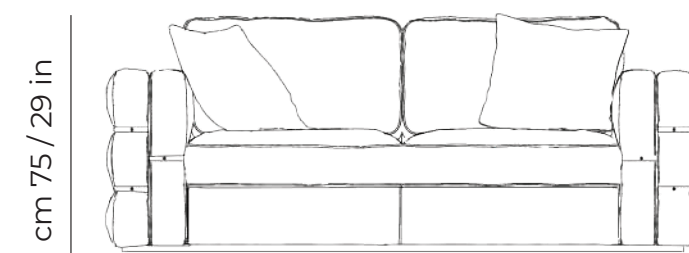

cm 75 / 29 in

cm 210 / 82 in

• *Ola Poltrona/Armchair*



Scocca in pelle art. Intrecciato col. Sabbia cat. 950. Braccioli in pelle art. Intrecciato col. Sabbia and Nashville col. Sabbia cat. 950. Sedute e dietro in pelle art. Nashville col. Sabbia cat. 950 con cuciture a contrasto col. Tortora cat. 950. Base e barre in acciaio



Body in leather art. Braided with. Sand cat. 950. Leather armrests art. Woven col. Sand and Nashville col. Sand cat. 950. Seats and back in leather art. Nashville col. Sabbia cat. 950 with contrasting stitching col. Tortora cat. 950. Steel base and bars

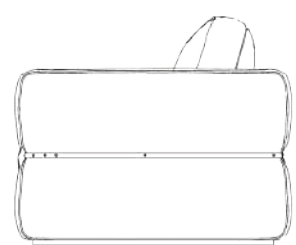

cm 100 / 39 in

cm 75 / 29 in



cm 92 / 36 in



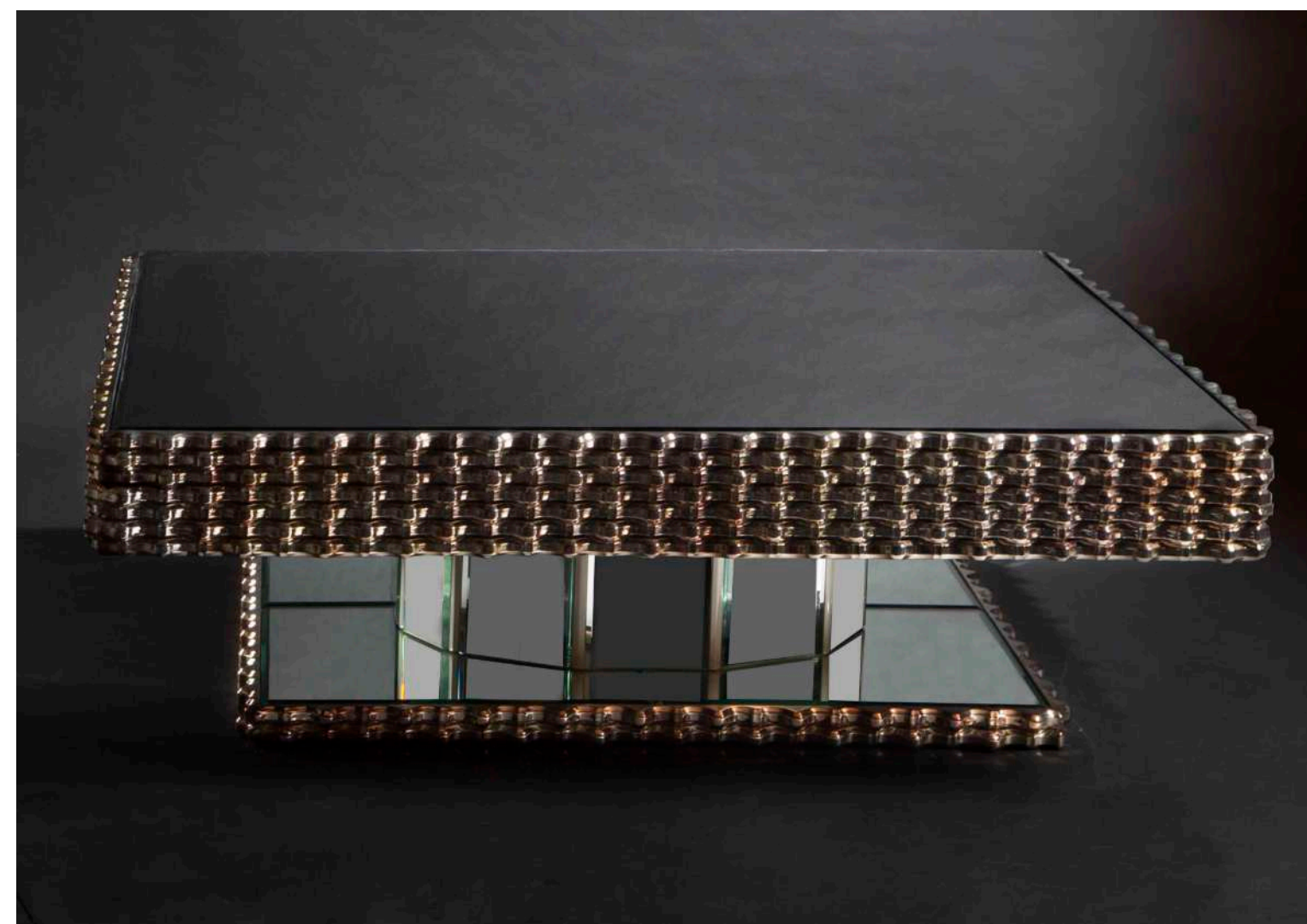
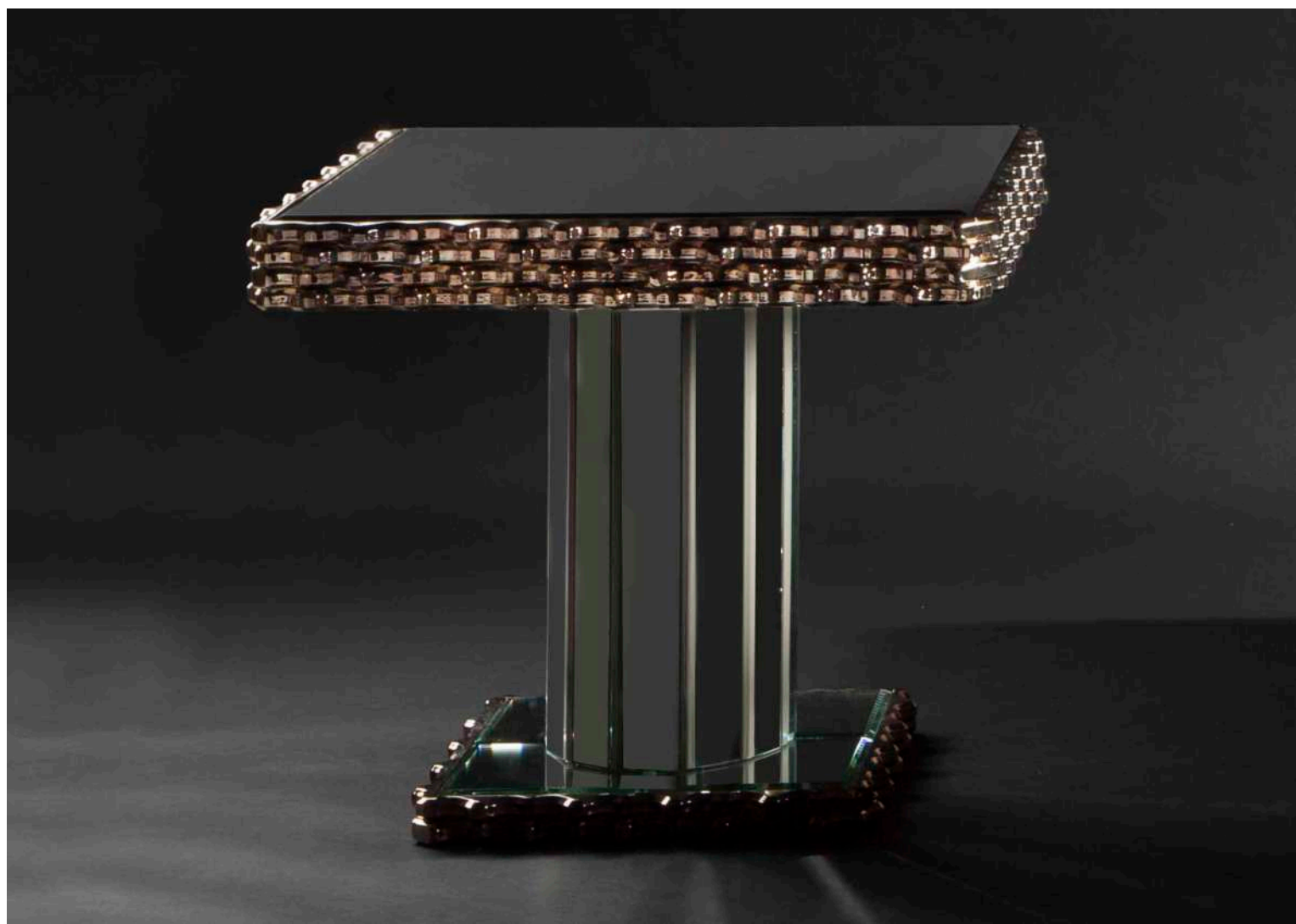

Finiture in foto:

Specchi bronzati molati;

Cornici in cromo anticato;

Finiture legno laccato lucido

col sabbia.

Finishes in the picture:

Ground bronzed mirrors;

Frames in antiqued chrome;

Polished lacquered wood with sand.

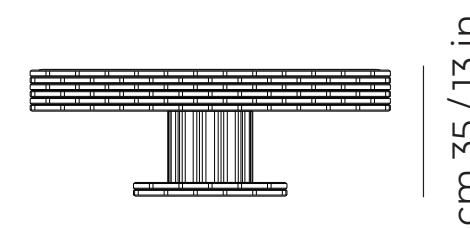
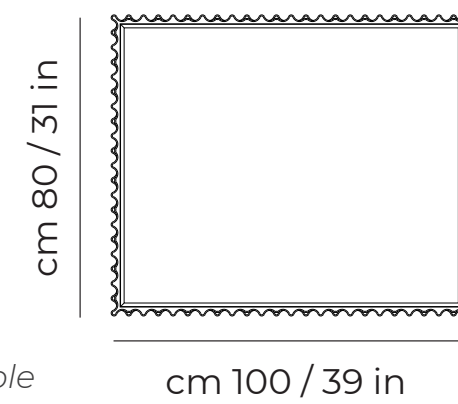
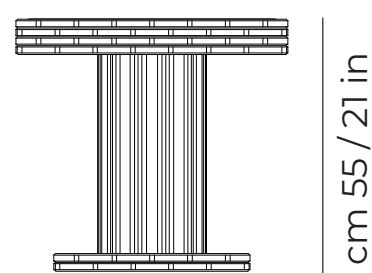
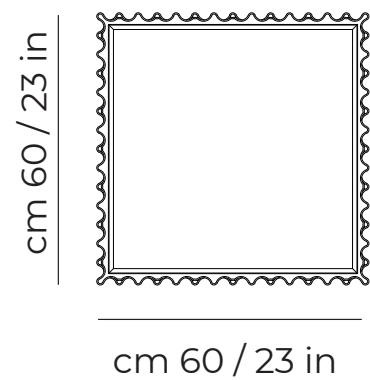

• *Ola Tavolino / Side Table*

• *Ola Tavolo da salotto / Coffee Table*



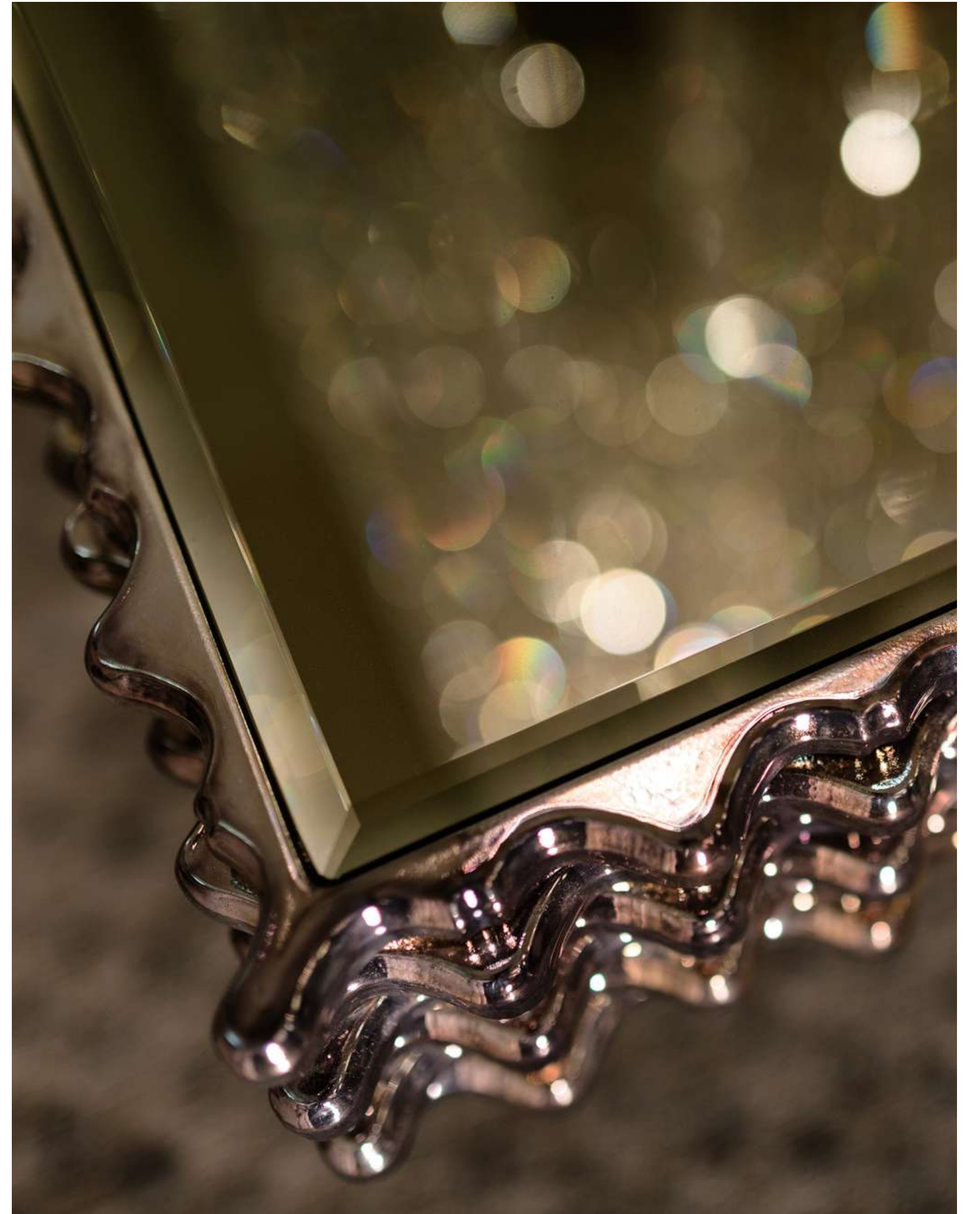



Ola

Letto / Bed



Il letto Ola è un prodotto funzionale dalle linee dinamiche e decise, le quali si fondono ad un ricercato dettaglio in cuoio realizzato sia sulla testata che sulla fascia del sommier. La zampa alta, disponibile in varie finiture, dona una leggerezza al prodotto e valorizza l'armonia delle forme.

The bed Ola is a functional product with dynamic and decisive lines, which are combined with a refined leather detail made both on the headboard and on the band of the sommier. The high paw, available in various finishes, gives a lightness to the product and enhances the harmony of the shapes.



cm 190 / 74 in

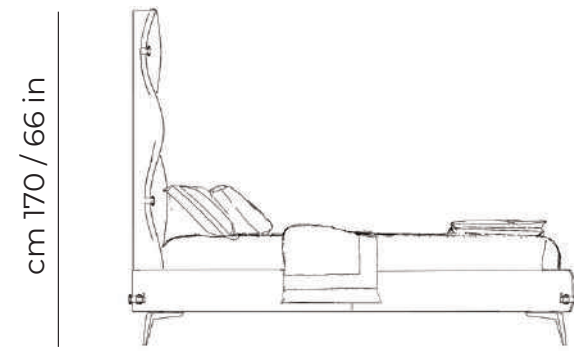

cm 170 / 66 in

cm 230 / 90 in





Ola

Comodino / Bed Side Table

Nel mondo raffinato della collezione Ola, il comodino è un elemento che si distingue con le sue linee sinuose e la sua dimensione poetica. Finiture come in foto:

Frontale dei cassetti rivestito in pelle Nashville col Sabbia cat. 95

Finitura lucido spazzolato col. Sabbia.

In the refined world of the Ola collection, the bedside table is an element that stands out with its sinuous lines and its poetic dimension. Finishes as in picture:

Front of drawers covered in Nashville leather with Sand cat. 95

Polished finish brushed col. Sand.

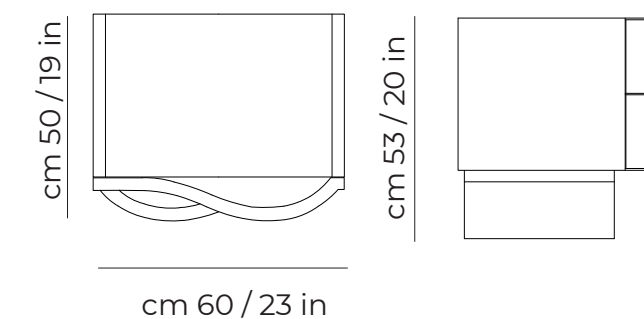

• Ola Pouf



Finitura come in foto:
Base in legno;
Imbottitura a tre
cannoni;
Specchi molati sulle
due parti laterali.

*Finish as in the picture:
Base in wood;
Padding with three
cannons;
Ground mirrors on
both sides.*

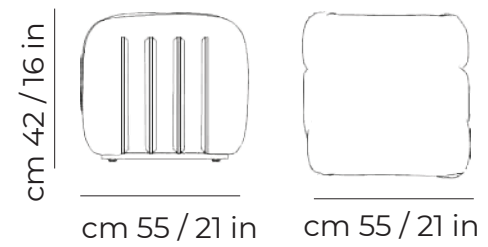





Ola

Toilette

Caratterizzata da una ribalta centrale con meccanismo di chiusura soft touch, la toilette Ola è perimetrata da tripla onda in finitura argentea. I top laterali sono rivestiti in pelle, mentre la ribalta centrale è laccata in beige.

Characterized by a central flap with soft touch closing mechanism, the Ola toilet is bordered by a triple wave in silver finish. The side tops are covered in leather, while the central flap is lacquered in beige.

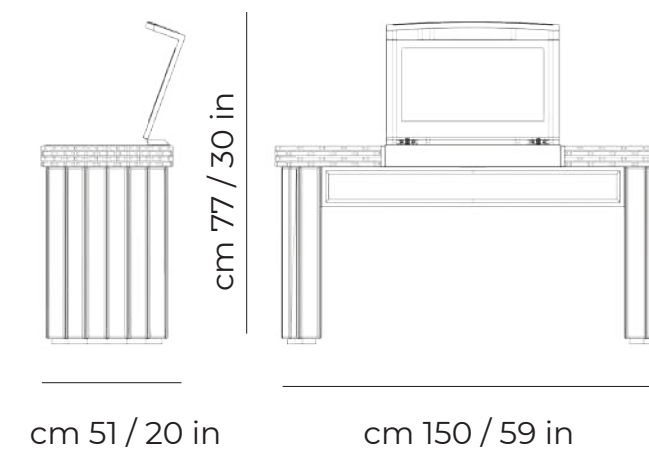



Ola settimino è un elemento di arredo composto da una struttura esterna personalizzabile in varie finiture laccate o impiallacciate, abbinata ad un sistema di cassetti realizzati in multistrato curvato rivestiti in pelle intrecciata, stampata o liscia a vostra scelta.

Ola settimino is a piece of furniture composed of a customizable external structure in various lacquered or veneered finishes, combined with a system of drawers made of curved plywood covered in woven, printed or smooth leather of your choice.

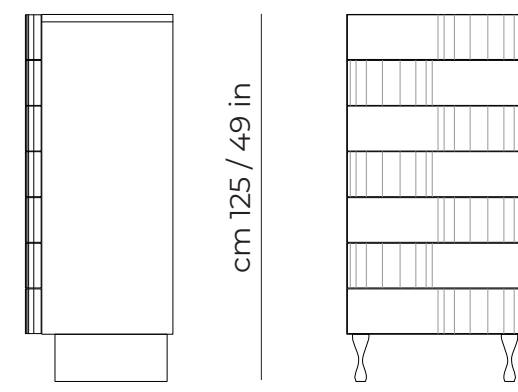

cm 50 / 19 in

cm 60 / 23 in





New York *brooklyn*



Per molti anni Brooklyn ha rappresentato l'anima operaia di New York, con i suoi quartieri d'immigrati ha accolto per decenni le persone che arrivavano negli Stati Uniti dal vecchio continente.

Oggi questa città è un moderno melting pot di culture e di etnie che hanno contribuito a creare uno stile originale, dove le varie tendenze s'incontrano e si fondono dando vita ad un nuovo gusto fatto di richiami alle proprie radici e di scelte innovative.

For many years Brooklyn has represented the working soul of New York, with its immigrant neighborhoods has welcomed for decades the people who arrived in the United States from the old continent.

Today this city is a modern melting pot of cultures and ethnicities that have contributed to create an original style, where the various trends meet and merge giving rise to a new taste made of references to their roots and innovative choices.



Cubo

Tavolo da salotto / *Coffee Table*

Tavolino da salotto dalla linea essenziale, reso prezioso dalla foglia di eucalipto frisee termotrattato sapientemente montata e trattata ad esaltarne la tridimensionalità della venatura. La base arretrata in lamiera di ottone brunito, solleva e alleggerisce la rigidità del monolite.

Coffee table for the living room with an essential line, made precious by the leaf of Frisian eucalyptus heat-treated expertly mounted and treated to enhance the three-dimensionality of the grain. The back base in burnished brass sheet, raises and lightens the rigor of the monolith.

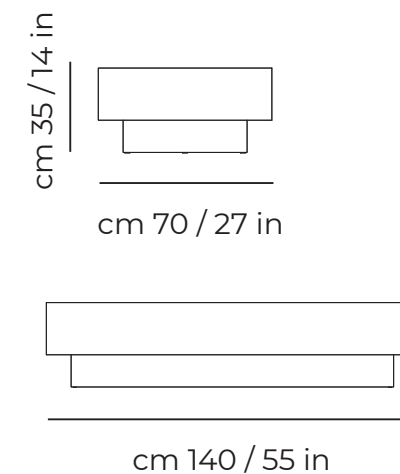

Peacock

Porta Tv / Tv Holder





La collezione Peacock rappresenta la più alta espressione ebanistica applicata ai pezzi che compongono la nostra linea di mobili contemporanea.

The Peacock collection represents the highest expression of cabinet-making applied to the pieces that make up our line of contemporary furniture.

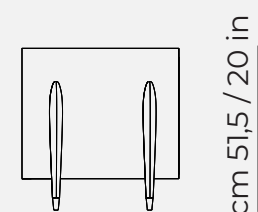

cm 50 / 19 in

cm 51,5 / 20 in

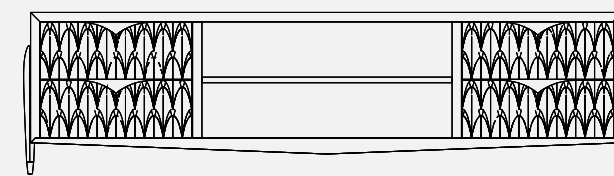

cm 193 / 75 in





Peacock

Tavolo da salotto / *Coffee Table*

La struttura esterna del tavolino, che può essere impiallacciata o laccata, viene rifinita da un massello sfaccettato sui bordi frontali. Le zampe tornite e il decoro in superficie che riprende la ruota del pavone, lo rendono un pezzo unico. Disponibile in due misure.

The external structure of the coffee table, which can be veneered or lacquered, is finished by a faceted solid wood on the front edges. The turned legs and the decoration on the surface that resumes the wheel of the peacock, make it a unique piece. Available in two sizes.

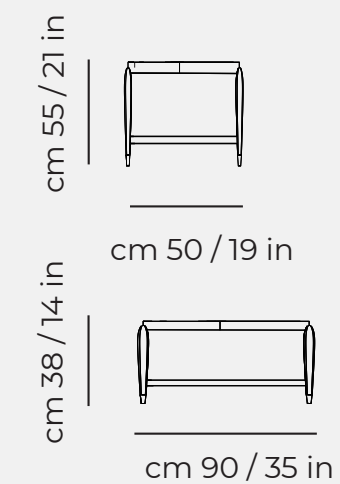



Peacock

Toilette

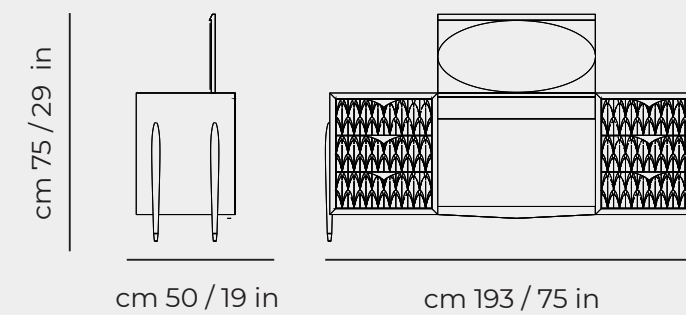

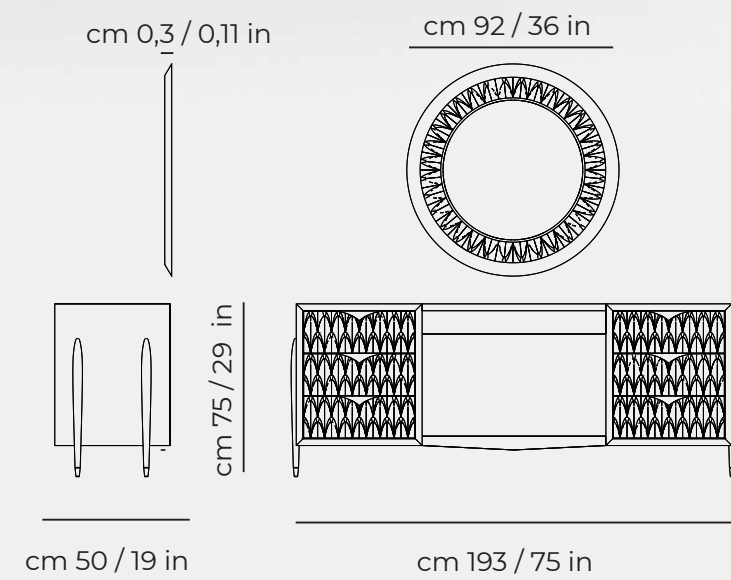

• Ola Specchio/Mirror





Fedro

Letto / Bed



La struttura della testata in multistrato è imbottita con in poliuretano espanso rivestito in fibra, trapuntata con una design esclusivo e arricchita da un logo ricamato.

La struttura del giroletto in multistrato con poliuretano espanso rivestito in fibra è attrezzata con i supporti delle reti regolabili in altezza. La traversa centrale è in metallo verniciato con supporti regolabili in altezza per l'utilizzo delle reti singole. Piedini in massello di faggio.

The structure of the multilayer headboard is padded with polyurethane foam covered with fiber, quilted with an exclusive design and enriched with an embroidered logo.

The structure of the bed frame in plywood with polyurethane foam covered in fiber is equipped with the supports of the nets adjustable in height. The central beam is in painted metal with height adjustable supports for the use of single nets. Feet in solid beech.

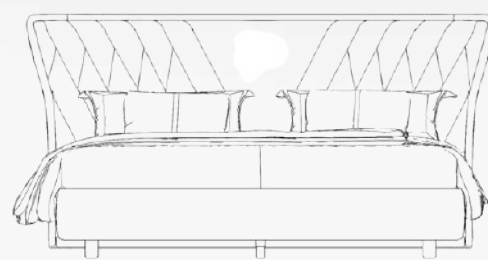

cm 217 / 84 in

cm 113 / 44 in

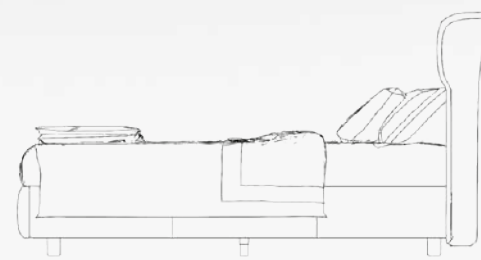

cm 218 / 85 in



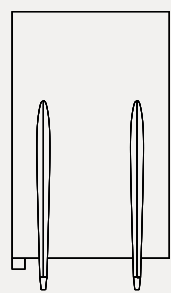

cm 50 / 19 in

cm 88 / 34 in

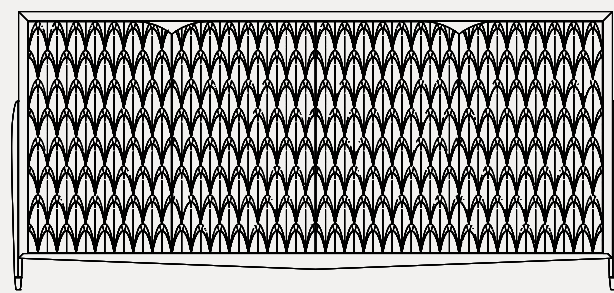

cm 193 / 75 in



Peacock Buffet

Peacock

Comodino / Bed Side Table

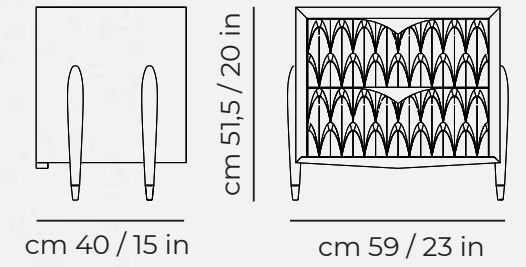





Londra royal

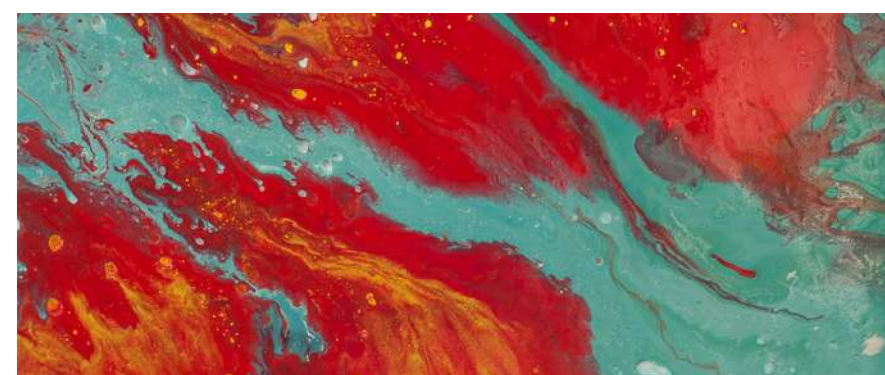

Londra, la città della famiglia reale ma anche avanguardia di stili e mode in tutti i campi. "Tradizione e innovazione" vanno a braccetto in questa collezione ispirata ad una città ricca di storia e cultura. Le tonalità calde delle finiture si alternano a dettagli di carattere che danno un tocco di unicità a tutti gli oggetti di questa collezione contraddistinta da forme e colori molto eleganti e ricercati.

London, the city of the royal family but also vanguard of styles and fashions in all fields. "Tradition and innovation" go hand in hand in this collection inspired by a city rich in history and culture.

The warm tones of the finishes alternate with details of character that give a touch of uniqueness to all the objects in this collection characterized by very elegant and refined shapes and colors.

La Perla

Divano / Sofa





La Perla è un divano raffinato ed elegante, grazie alla base sollevata da terra con piedini torniti in finitura come da cartella Mantellassi; stessa finitura per il profilo in legno che, correndo sopra la spalliera ed il bracciolo, ne sottolinea le forme.

La Perla Chic is a refined and elegant sofa, thanks to the base raised from the ground with turned feet in finish as from Mantellassi; same finish for the wooden profile that, running over the backrest and the armrest, emphasizes its forms.



cm 113 / 44 in

cm 98 / 38 in

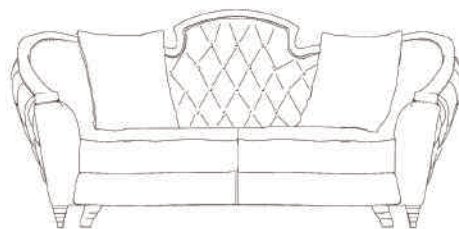

cm 205 / 80 in

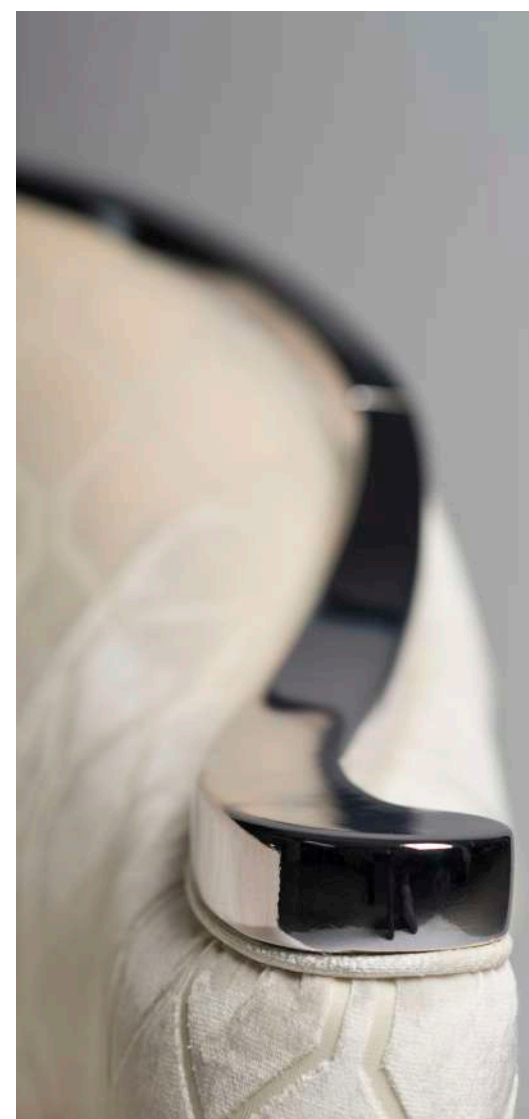

La Perla

Poltrona / Armchair

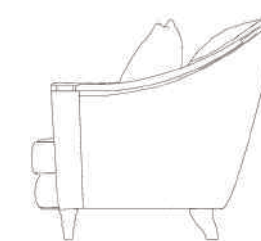

cm 105 / 41 in

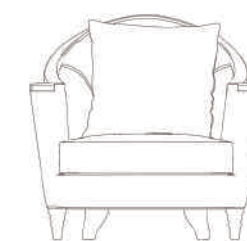

cm 93 / 36 in



• *La perla Poltrona / Armchair*

Mantellassi / *Cosmopolitan*





Chiaraluna

Lampada da parete / Wall lamp

Eteera e stravagante, la Chiaraluna è composta da un elemento centrale ed un elemento terminale che possono venire accostati all'infinito. La struttura è in ferro battuto con finitura foglia oro anticato e ninfea in vetro di Murano

Ethereal and extravagant, the Chiaraluna is composed of a central element and a terminal element that can be approached to infinity. The structure is in wrought iron with antiqued gold leaf finish and water lily in Murano glass

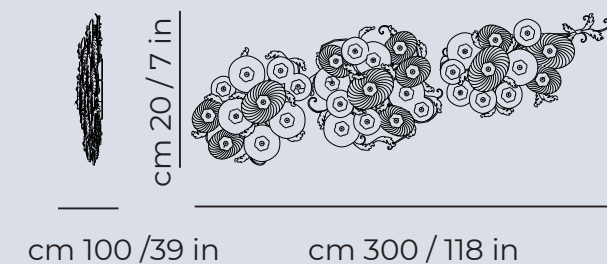







Lady D

Letto / Bed

Lady D è un letto raffinato ed elegante, grazie alla base sollevata da terra con piedini torniti in finitura come da cartella Mantellassi che ne aumentano il fascino decò.

Lady D is a refined and elegant bed, thanks to the base raised from the ground with turned feet in finish as per folder Mantellassi that increase the charm decò.

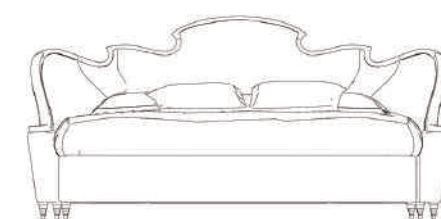

cm. 270 / 106 in

cm. 131 / 51 in



cm. 250 / 98 in



La Perla

Dormeuse

La dormeuse La Perla si caratterizza per la sua leggerezza e armonia delle forme, sottolineate dalla cornice in massello di faggio rifinita nelle diverse finiture disponibili. La spalliera è impreziosita dalla lavorazione in capitonnè che permette di inserire il prodotto in contesti sia contemporanei che classici.

La Perla dormeuse is characterized by its lightness and harmony of shapes, underlined by the frame in solid beech finished in the different finishes available. The wall bar is embellished by the capitonnè workmanship that allows to insert the product in both contemporary and classic contexts.

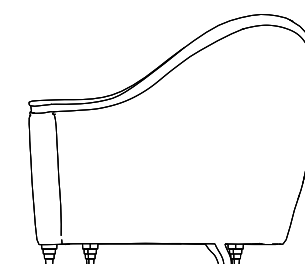

cm. 105 / 41 in

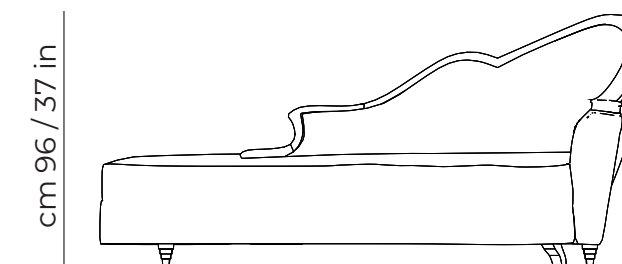

cm 96 / 37 in

cm. 195 / 77 in





Londra sky



Non solo grigio. Il cielo di Londra a volte sa regalare scorci ineguagliabili ed è sotto questa luce che abbiamo immaginato la nostra collezione. I colori di sottobosco e le atmosfere accoglienti sono intervallate da linee eleganti e decise che contribuiscono a creare un ambiente caldo e ordinato, in pratica la situazione ideale per la pausa tè in un pomeriggio piovoso.

Not only gray. The sky of London sometimes knows how to give unparalleled views and it is in this light that we imagined our collection. The colors of undergrowth and the cozy atmosphere are interspersed with elegant and decisive lines that help create a warm and tidy environment, in practice the ideal situation for the tea break on a rainy afternoon.



Mantellassi / *Cosmopolitan*

Nuvola

Divano / *Sofa*



Tecnicamente è realizzato con struttura in abete massello. Telaio sedile in abete. Imbottitura in poliuretano espanso a densità differenziata con rivestimento in fibra acrilica. Molleggio a nastri elastici intrecciati di caucciù rivestito. Disponibile solo in pelli morbide.

Technically it is made with solid fir structure. Seat frame in fir. Padding in differentiated density polyurethane foam with acrylic fiber coating. Springing with woven elastic bands of coated rubber. Only available in leathers

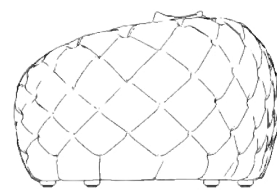

cm 115 / 61 in

cm 89 / 31 in

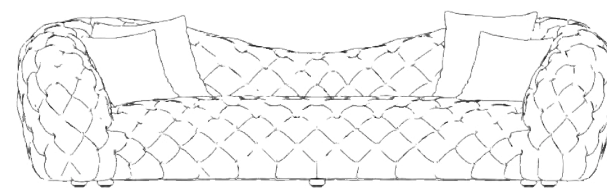

cm 300 / 118 in



Nella modellistica trapuntata a capitonné è un benchmark. La poltrona Nuvola è realizzabile solo da provetti falegnami e tappezzieri, capaci di plasmare a mano libera il manto di pelle bovina attorno alla complessa struttura di supporto.

In quilted capitonné modeling it is a benchmark. The Nuvola armchair can only be made by skilled carpenters and upholsterers, able to shape the cowhide coat around the complex support structure.

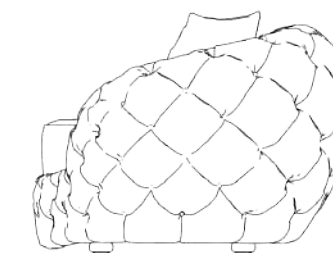

cm 110 / 43 in

cm 80 / 31 in



cm 125 / 49 in

Over

Poltrona / Armchair





Per la sua straordinaria versatilità, la poltrona Over si colloca in qualsiasi ambiente, è fantastica in ogni rappresentazione stilistica. Rivestimento in shearling naturale. Pelle art. Nuvola col. Bianco cat. 800. Struttura in colatura di bronzo con finitura oro 24K Base in legno con finitura foglia oro.

For its extraordinary versatility, the Over armchair is placed in any environment, it is fantastic in every stylistic representation. Cover in natural shearling. Leather art. Cloud col. White cat. 800. Structure in cast bronze with gold finish 24K. Wooden base with gold leaf finish.

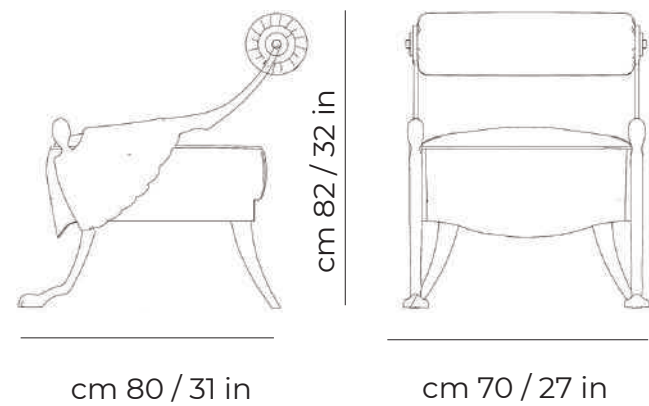

- Nuvola Tavolino / Side Table
- Nuvola Tavolo da salotto / Coffee Table

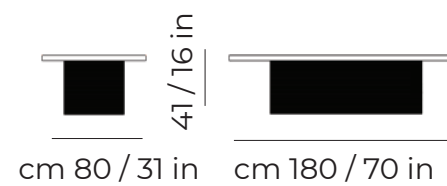
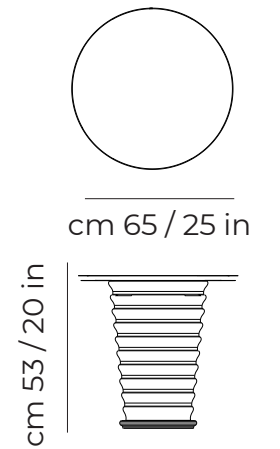



45 / 17

51 / 20

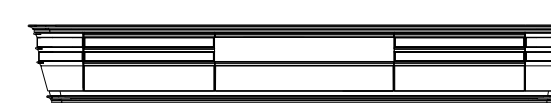

cm 350 / 137 in

◆ *Nuvola Porta TV*

Vanesio

Poltrona / Armchair





Questa poltroncina presenta una solida struttura in nero laccato semi-lucido ed un rivestimento in tessuto bouclé in bianco e blu ottanio, rifinito con bordini in gross grain.

This armchair has a solid structure in semi-gloss lacquered black and a cover in bouclé fabric in teal blue and white, finished with edges in gross grain.

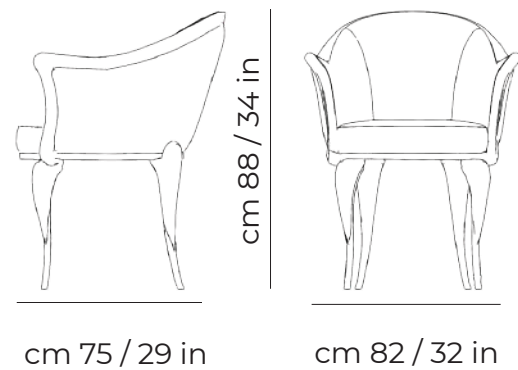





Così come gli altri prodotti della collezione, la sedia Vanesio è caratterizzata dalle linee morbide e sinuose del legno a vista e dalle particolari scanalature lungo le zampe.

Like the other products in the collection, the Vanesio chair is characterized by the soft and sinuous lines of exposed wood and by the particular grooves along the legs.

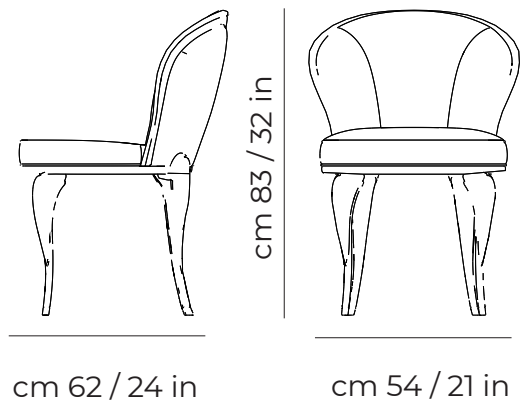



Vanesio

Tavolo da pranzo / Dining Table

Il tavolo Vanesio è un pezzo d'arredo che deriva dall'arte ebanista toscana, con linee sinuose e fluide. Il legno finemente lavorato viene rifinito con preziose laccature semilucide per sottolineare i volumi scultorei. In questo caso il bordo del piano è stato decorato in foglia oro.

The Vanesio table is a piece of furniture that derives from the art of Tuscan cabinetmaker, with sinuous and fluid lines. The finely worked wood is finished with precious semi-gloss lacquers to emphasize the sculptural volumes. In this case the edge of the top was decorated in gold leaf.

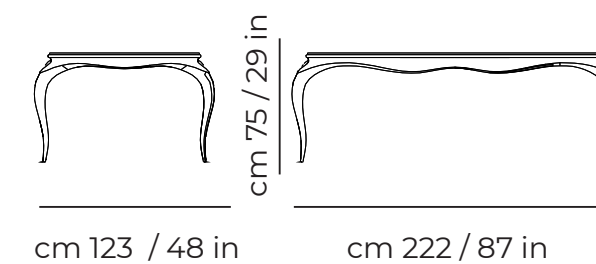

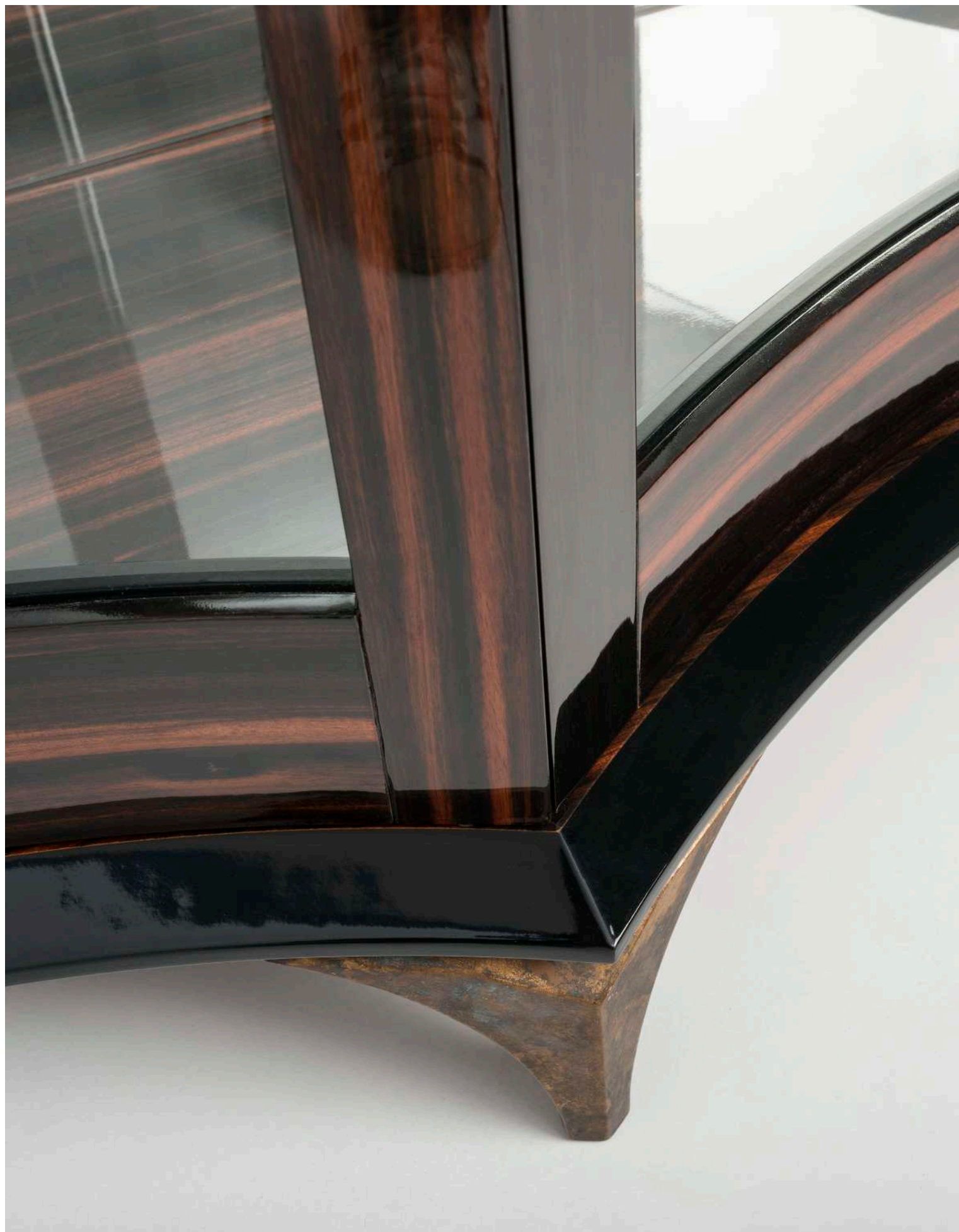

Ermes

Vetrina / Showcase

La struttura è in legno curvato, impiallacciato in ebano Macassar con cristalli molati.

Le zampe tridimensionali donano quel tocco di unicità, propria degli oggetti d'arte.

The structure is in curved wood, veneered in Macassar ebony with ground crystals.

The three-dimensional paws give that touch of uniqueness, typical of art objects.

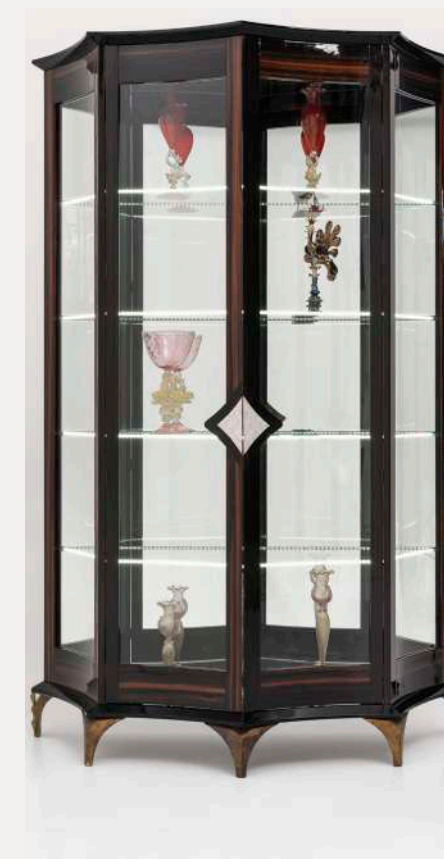
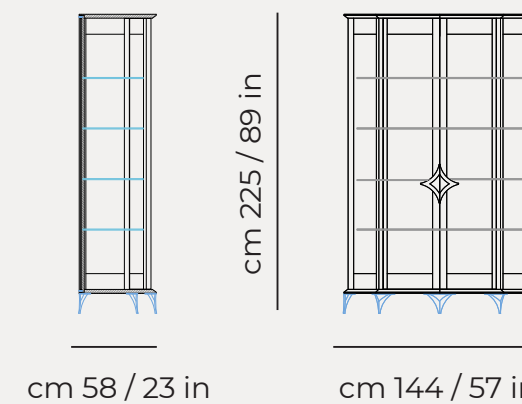





Parigi nouvelle



La città delle luci soffuse dei quadri di Toulouse-Lautrec, del Moulin Rouge ma anche della Cattedrale di Notre-Dame e del Sacre-coeur. Della grandiosità di alcuni imperatori e dei mercatini di libri lungo la Senna. Una città ricca di aspetti che ha sempre offerto infiniti spunti d'ispirazione agli artisti di tutto il mondo.

The city of soft lights of the paintings of Toulouse-Lautrec, the Moulin Rouge but also of the Notre-Dame Cathedral and the Sacre-coeur. The grandeur of some emperors and the book markets along the Seine. A city rich in aspects that has always offered endless inspiration to artists from all over the world.

Fedro

Divano / Sofa





Elegante divano con una complicata realizzazione di trapuntatura della spalliera. La struttura in acciaio acidato a mano, determina pregio e solidità nel tempo.

Elegant sofa with a complicated quilting of the wall bars. The structure in hand-etched steel, determines value and solidity over time.

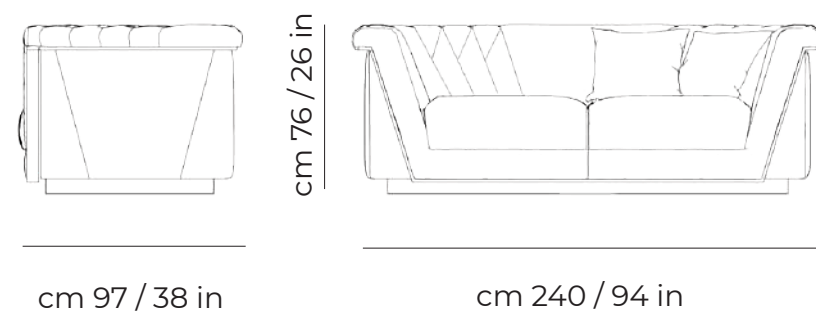

La struttura è in ebano macassar laccato lucido con striature in arancio sfumato e le ante sono rivestite in pergamena anticata con lavorazioni in legno con taglio geometrico triangolare in una splendida finitura foglia oro.

The structure is in polished lacquered macassar ebony with shaded orange streaks and the doors are covered in antiqued parchment with wooden works with triangular geometric cut in a beautiful gold leaf finish.

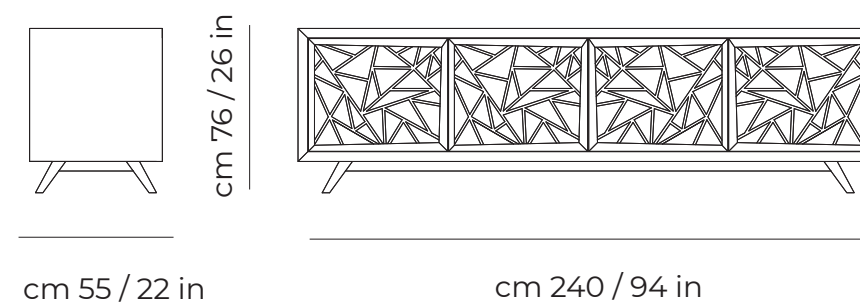

• Gillo Porta TV / Tv Holder





• *Martini Bar*

Martini Bar è un complemento di arredo di assoluta eleganza e funzionalità. Una base leggera e longilinea in legno massello laccato, sulla quale si appoggia il corpo del bar. Un mobile da scoprire in ogni suo dettaglio.

Martini Bar is a piece of furniture of absolute elegance and functionality. A light and long base in lacquered solid wood, on which rests the body of the bar. A piece of furniture to be discovered in every detail..

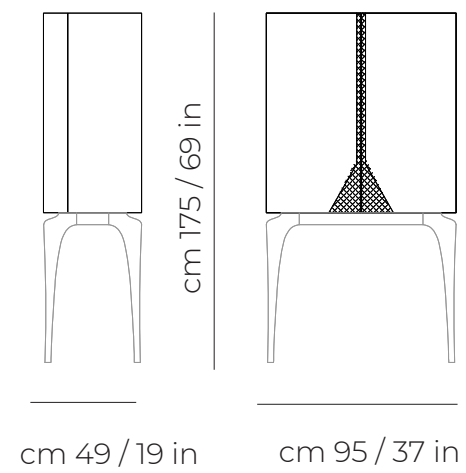



Liu

Consolle





Consolle in legno con finiture in pergamena lucidata e tirata a resina bordeaux scuro, zampe in legno laccato nero e zampa centrale con decorazioni in foglia oro acidato

Wooden console table with polished parchment finishes and dark burgundy resin pull, legs in black lacquered wood and central paw with gold-etched leaf decorations

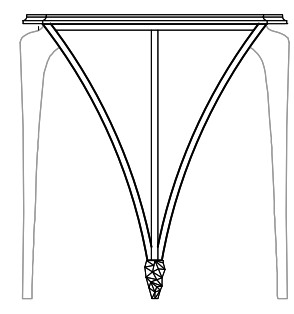
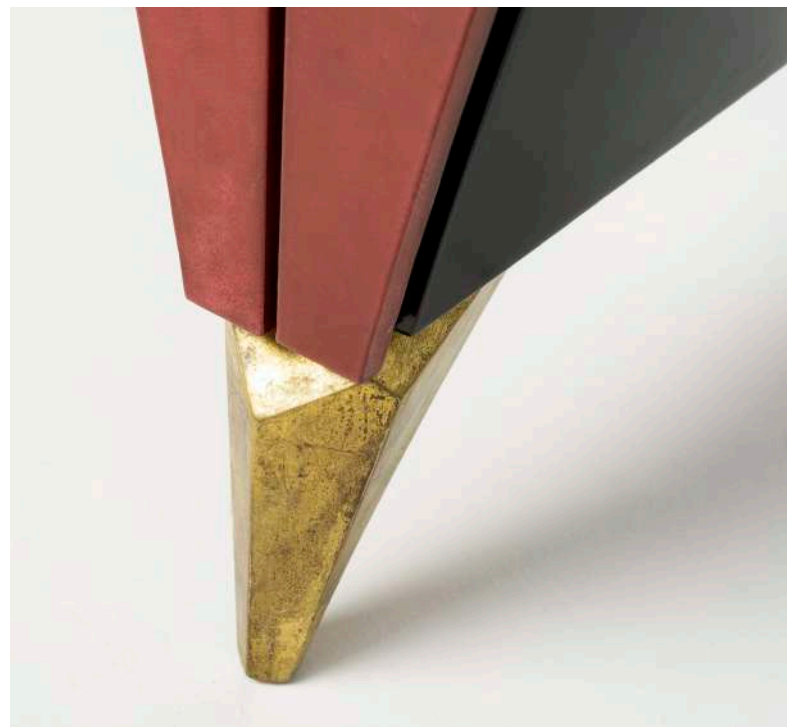

cm 84 / 33 in

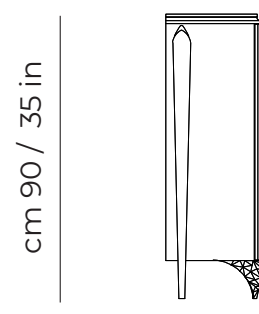

cm 90 / 35 in

cm 30 / 12 in





Michelangelo

Sedia / Chair



Le sedie Michelangelo sono proposte nelle due altezze, standard e capotavola. Struttura in massello di faggio rivestito per la spalliera e in massello di faggio laccato per la base. Pelle art. Nuvola col. Testa di Moro cat. 800. Finitura in ottone dorato.

Michelangelo chairs are available in two heights, standard and head table. Structure in solid beech covered for the wall bars and in solid lacquered beech for the base. Leather art. Nuvola col. Testa di Moro cat. 800. Golden brass finish.

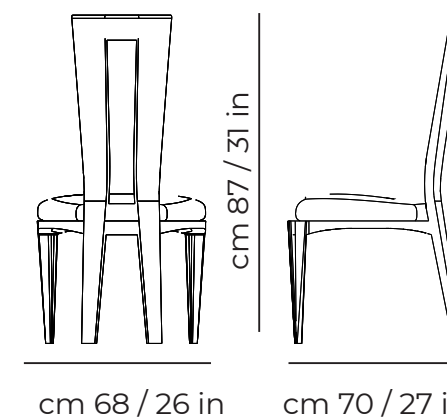







Parigi boulevard



In questa collezione la luce delle finiture dorate rappresenta la “grandeur” di Versailles e del Palais Royal. A tutto questo ci siamo ispirati per creare una collezione dove le linee di sapore art-decò si alternano a forme morbide deliziosamente liberty mentre su tutto domina un gusto di fondo che s’ispira allo stile delle colonie Indocinesi.

In this collection the light of the golden finishes represents the “grandeur” of Versailles and the Palais Royal. All this inspired us to create a collection where the lines of art-deco flavor alternate with soft forms deliciously Art Nouveau while on everything dominates a basic taste that is inspired by the style of the Indochinese colonies.

Bon Voyage

Divano / Sofa





Rivestimento come foto: Pelle Nabuk
con zampe laccate acciaio.

*Cover as photo: Nabuk leather with
legs lacquered steel.*

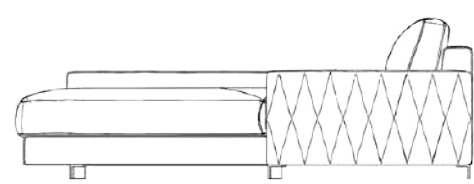

cm 235 / 95 in

cm 82 / 32 in

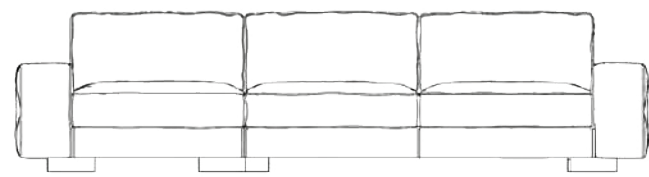

cm 323 / 127 in



Una poltrona dalle forme avvolgenti e di grande comfort. Il profilo in acciaio ed il bracciolo in legno di faggio tinto ciliegio rafforzano il concetto di unicità del pezzo.

An armchair with enveloping shapes and great comfort. The steel profile and the armrest in cherry-stained beech wood reinforce the concept of uniqueness of the piece.

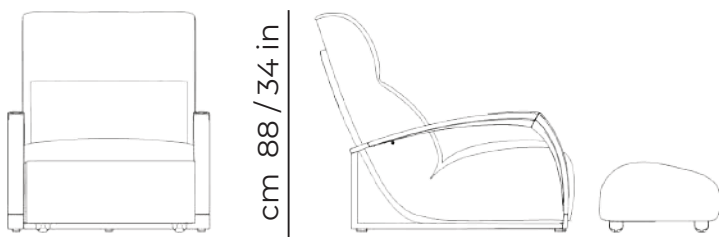

cm 82 / 32 in

cm 107 / 42 in



• *Tango Poltrona*





• *Blaze Porta Tv / Tv Holder*



Pontecorvo

Sedia / Chair



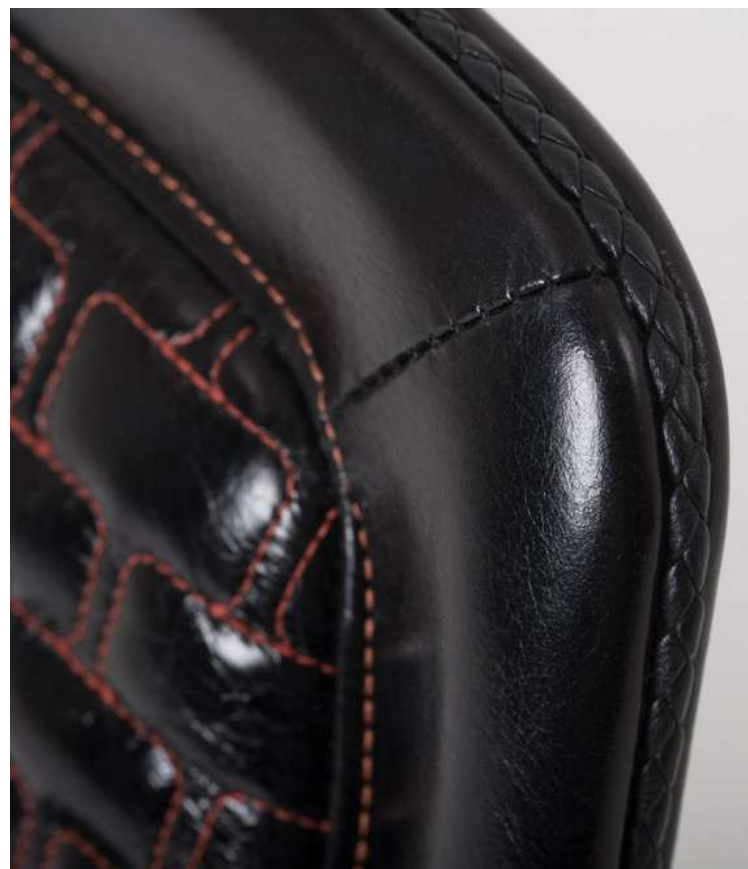

La sedia Pontecorvo presenta una base in faggio molto leggera con zampe rastremate in maniera scultorea, sulla quale poggia la seduta rivestita con una pregiata ed elegante pelle.

The Pontecorvo chair has a very light beech base with sculptural tapered legs, on which rests the seat covered with a fine and elegant leather.

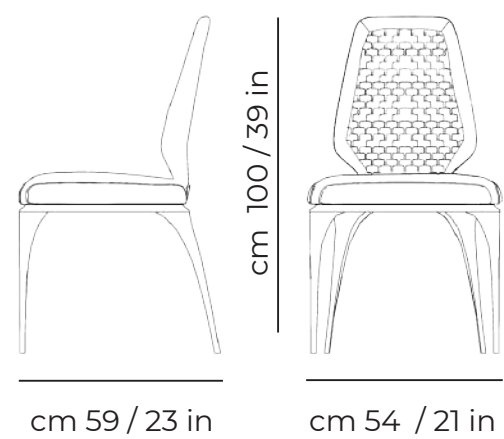

Pontecorvo

Tavolo da pranzo / *Dining Table*





Grande tavolo impiallacciato in ebano Macassar: piano impiallacciato lucidato a specchio con bordo in legno massello sfaccettato in 3D, base con zampe ad arco in legno e acciaio verniciato.

Large table veneered in Macassar ebony: mirror polished veneer top with 3D faceted solid wood edge, base with arched legs in wood and painted steel.

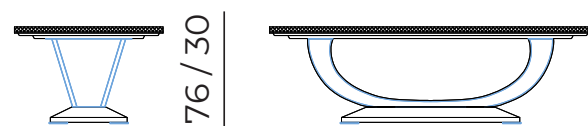

cm 120 / 47 in

cm 260 / 102 in





Ermes

Buffet

Le zampe in legno, lavorate con una sfaccettatura tridimensionale diamantata, esprimono un carattere distinto e sofisticato. Gli sportelli sono incavi stoncati e i cassetti al loro interno sono realizzati con una lavorazione diamantata tridimensionale. La finitura consigliata è in foglia oro acidata e anticata a mano.

The wooden legs, worked with a three-dimensional diamond facet, express a distinct and sophisticated character. The doors are recessed and the drawers inside are made with a three-dimensional diamond. The recommended finish is in gold leaf etched and antiqued by hand.

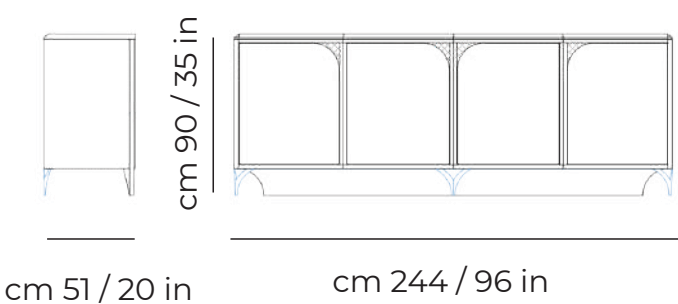





Collection

COSMOPOLITAN

Schede tecniche / Technical sheets

Divani / Sofas

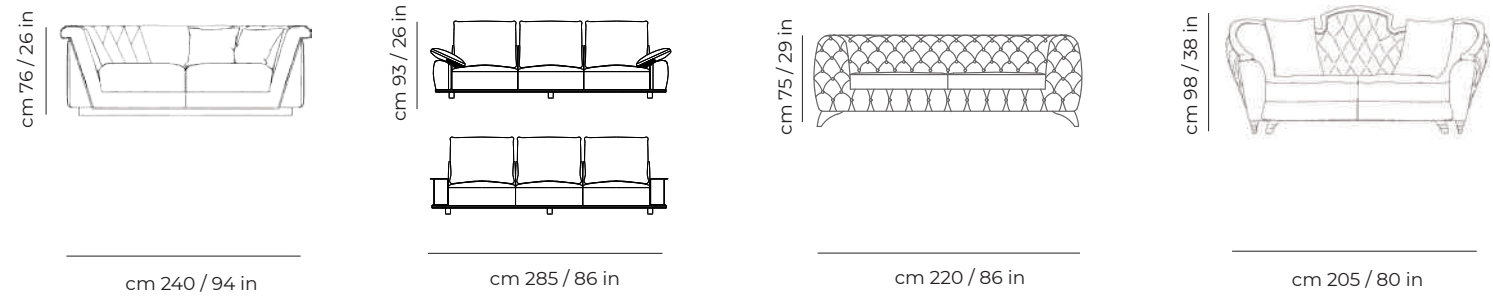

Fedro Grand Tour Isidoro La Perla

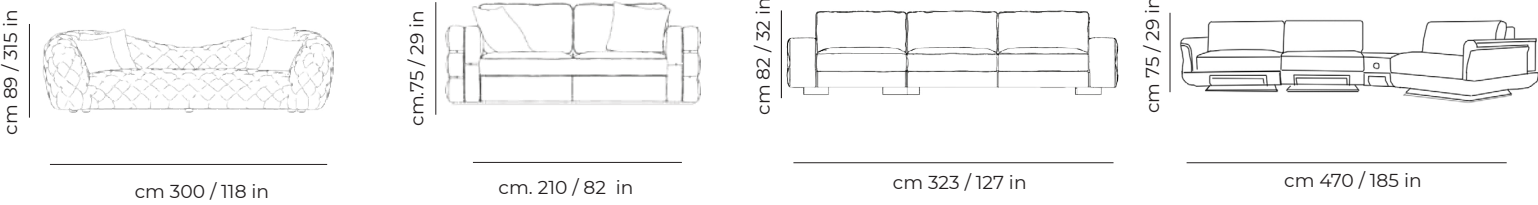

Nuvola Ola Bon Voyage Adone

Poltrone / Armchairs

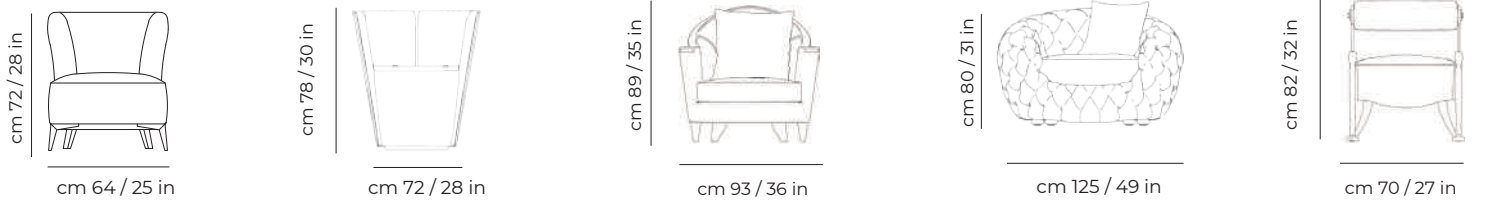

Agostina Barrel La Perla Nuvola Over

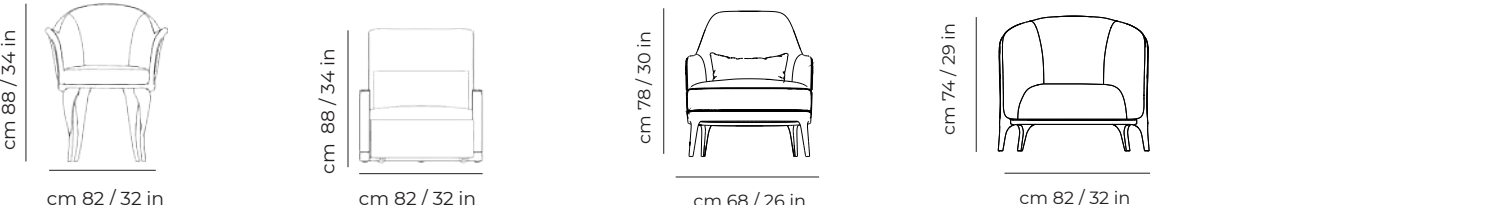

Vanesio Tango Souvenir Katrine

Mantellassi / Cosmopolitan

Pouff

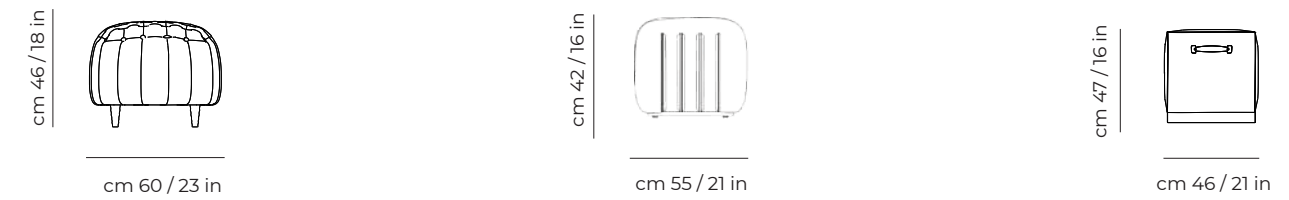

La Perla Ola Fedro

Libreria / Bookcase

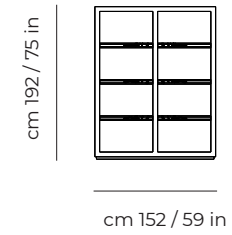

Grace

Dormeuse e Panche / Dormeuse and bench

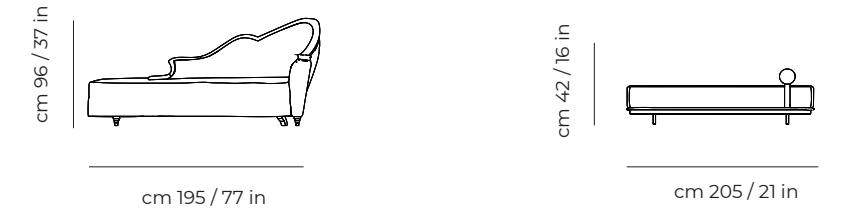

La Perla Aston

Sedie / Chairs

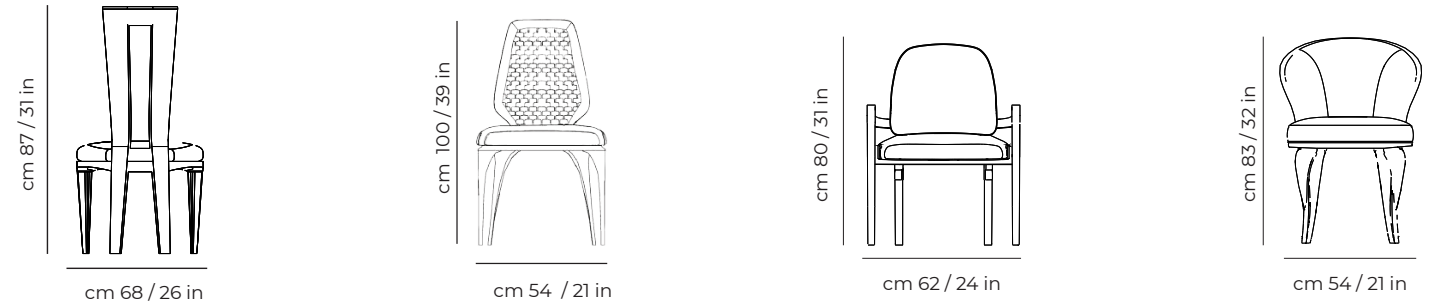

Michelangelo Pontecorvo Pheasant Vanesio

Letti / Beds

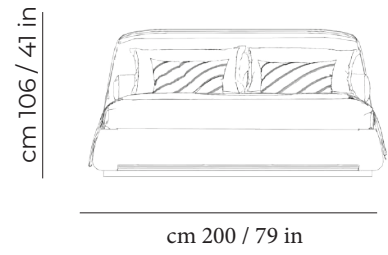

Aurora

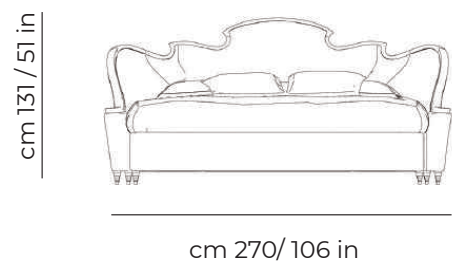

Lady D

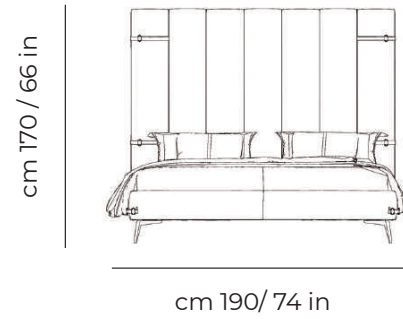

Ola

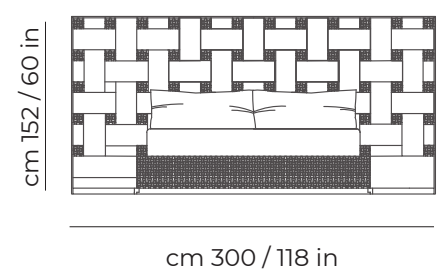

Romeo

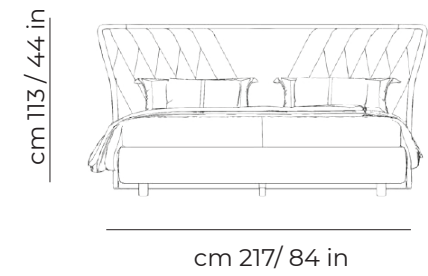

Fedro

Comodini / Bed Side Table

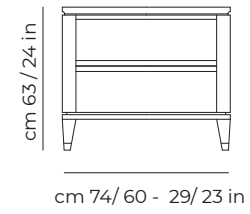

Ercolino

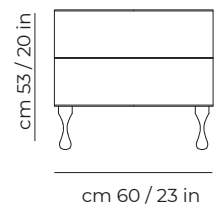

Ola

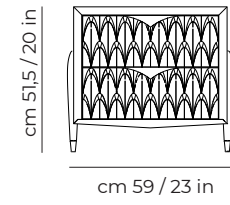

Peacock

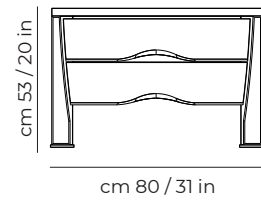

Gessato

Cassettoni / Dresser

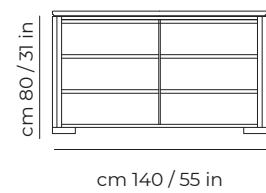

Ercole

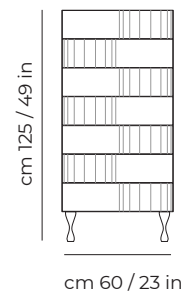

Ola Settimino

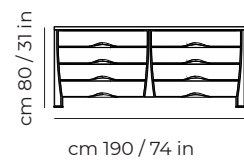

Gessato

Mantellassi / Cosmopolitan

Buffet

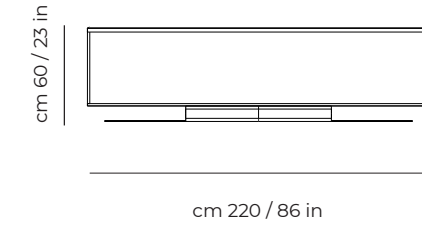

Blaze

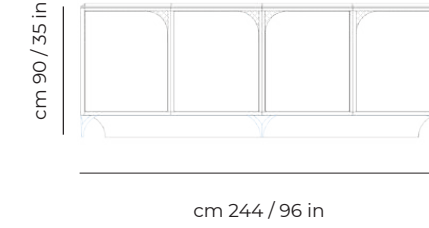

Ermes

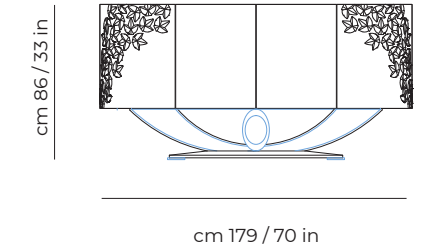

Mimosa

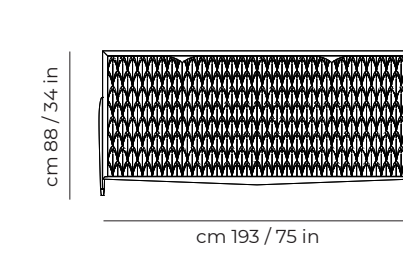

Peacock

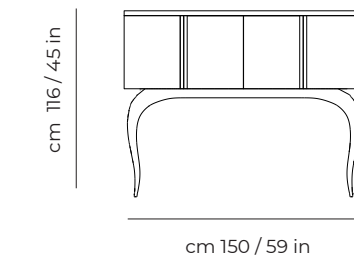

Vanesio

Toilette e Specchi / Toilette and Mirrors

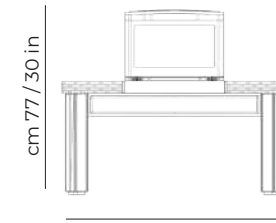

Ola

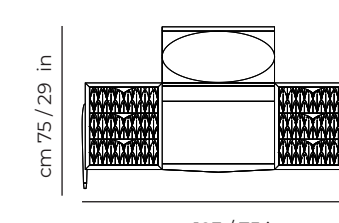

Peacock

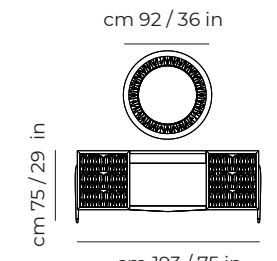

Peacock

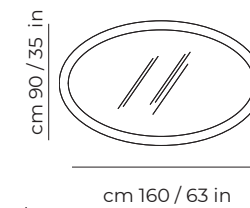

Gioconda

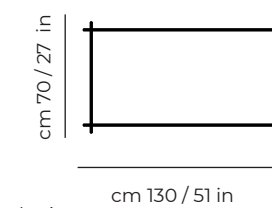

Shanghai

Applique e Lampade da parete / *Applique and Wall Lamp*



cm 112 / 44 in

Le Fate

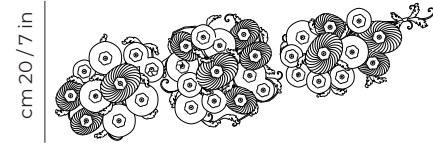

cm 20 / 7 in

Chiaraluna

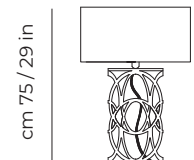

cm 75 / 29 in

Violante

Bar e Vetrine / *Showcase*

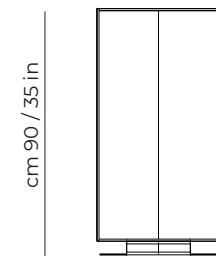

cm 90 / 35 in

Blaze

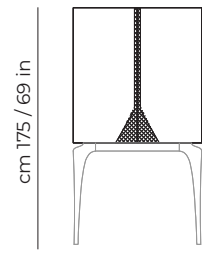

cm 175 / 69 in

Martini

Consolle

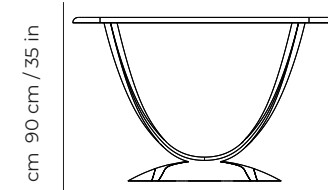

cm 90 cm / 35 in

Arco

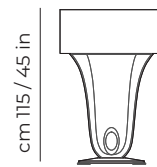

cm 115 / 45 in

Mimosa

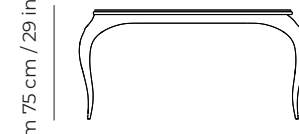

cm 75 cm / 29 in

Vanesio

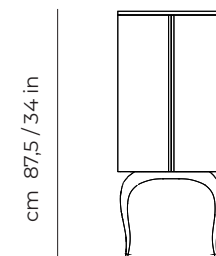

cm 87,5 / 34 in

Vanesio

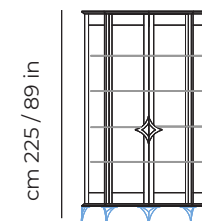

cm 225 / 89 in

Hermes

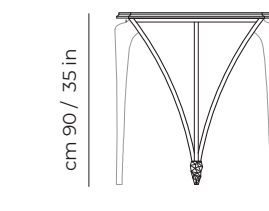

cm 90 / 35 in

Liu

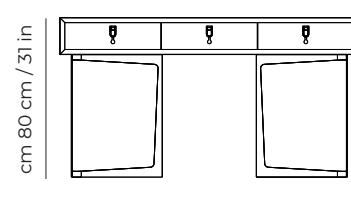

cm 80 cm / 31 in

Shanghai

Tavolo da pranzo / *Dining Table*

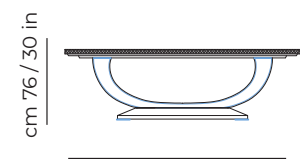

cm 76 / 30 in

Pontecorvo

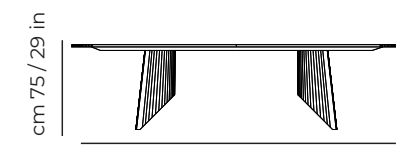

cm 75 / 29 in

Scultura

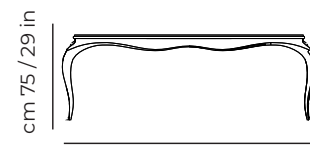

cm 75 / 29 in

Vanesio

Porta Tv / *Tv Holder*

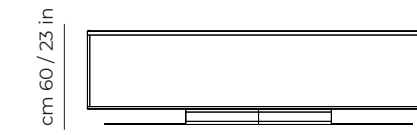

cm 60 / 23 in

Blaze

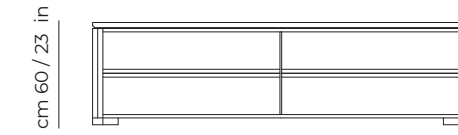

cm 60 / 23 in

Ercole

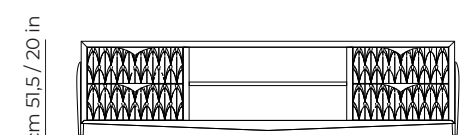

cm 51,5 / 20 in

Peacock



cm 51 / 20

Nuvola

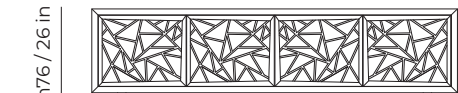

cm 76 / 26 in

Gillo

Tavolino / *Side Table*

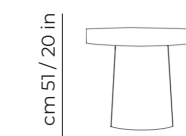

cm 51 / 20 in

Cono

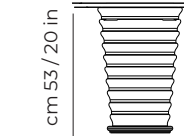

cm 53 / 20 in

Nuvola

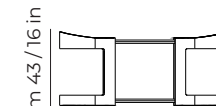

cm 43 / 16 in

Globo

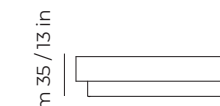

cm 35 / 13 in

Cubo



41 / 16 in

Nuvola

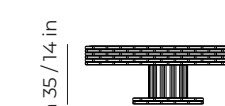

cm 35 / 14 in

Ola

Tavolo da salotto / *Coffee Table*

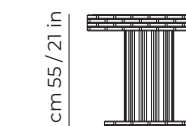

cm 55 / 21 in

Ola



cm 50 / 19 in

Plettro



cm 50 / 19 in

Scarlett

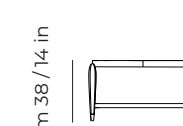

cm 38 / 14 in

Peacock



cm 50 / 19 in

Saturno

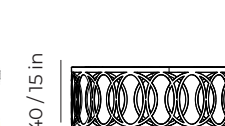

cm 40 / 15 in

Scarlett

Mantellassi / *Cosmopolitan*

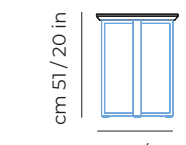

cm 51 / 20 in

Scricciolo

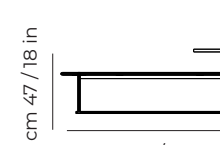

cm 47 / 18 in

Skyline

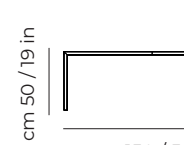

cm 50 / 19 in

Zaza



M1926

MANTELLASSI