

# EPÒNIMO

2024 COLLECTION



<b>Sexy Beast</b>	2	<b>Rock</b> table	70
<b>Big Bubble</b>	6	<b>Wood</b> table	74
<b>Big Game</b>	12	<b>Nadi</b> table	76
<b>Nova</b> lounge	14	<b>Roll</b> table	78
<b>Nova</b> pouf	16	<b>Big Sur</b> desk	80
<b>Nova</b> two-seater	18	<b>Rock</b> low table	82
<b>Gotham</b> armchair	20	<b>Ghost</b> low table	86
<b>Gotham</b> two-seater	24	<b>Wood</b> low table	88
<b>Exo</b>	26	<b>Roll</b> low table	90
<b>Endo</b> armchair	28	<b>Big Sur</b> low table	94
<b>Nova</b> lounge chair	32	<b>MT</b> low table	96
<b>Heritage</b>	34	<b>Bic</b> low table	98
<b>Gotham</b> small armchair	36	<b>Toid</b> side table	100
<b>Nova</b> small armchair	40	<b>Rock</b> side table	104
<b>OW</b>	42	<b>Rock</b> nightstand	106
<b>Medven</b> small armchair	44	<b>Wood</b> side table	108
<b>Medven</b> two-seater	46	<b>Roll</b> side table	110
<b>“O”</b>	48	<b>MT</b> side table	114
<b>New Outline</b>	50	<b>Long Playing</b> side table	118
<b>Nova</b> chair	52	<b>Gotham</b> side table	120
<b>Nua</b>	56	<b>New Outline</b> bench	122
<b>Bic</b>	60	<b>Gotham</b> bench	124
<b>Aluchair</b>	64	<b>Long Playing</b> étagère	126
<b>Alustool</b>	68	<b>Gotham</b> wardrobe	130

## 2025 Collection

Our collection mediates between memories of the past and opportunities of the present, integrating familiarity with aesthetic and technical innovation, the core elements of contemporary furniture. The execution of Eponimo's pieces is always technically modern but their aesthetic inspirations span through time: most are original concepts developed with a strong modern identity, while some evolve from promising archetypes and models from the past. We work with high-quality natural materials and our products are largely hand-made and always hand-finished. Ultimately they are functional, comfortable, elegant and unique.



## Sexy Beast

Rich, plush, round volumes and luscious comfort in a small-sized sofa. The ends of the armrests and backrest are angled at 45 degrees: this visual trick greatly increases the perceived width of the elements and the perceived size of the sofa. In addition, while Sexy Beast is not a sectional piece, the angle helps to position two matching sofas in a typical L-shaped composition. We use an absolute minimum amount of polyurethane and only in a very few critical points. Comfort is obtained through elastic straps, dacron and natural down. The cover is fully removable.

Solid poplar or pine and poplar or pine plywood internal frame. Elastic support straps, polyurethane core, dacron lining, with covers in cotton velvet, aniline leather or customer fabric, down-filled seat cushions.







## Big Bubble

An essential and yet sumptuous sofa that integrates an unprecedented level of comfort and a clean image through the careful study of proportions, filling materials and surface treatment. It is a mint product that combines the flair of something lived-in with the appeal of modern performance. The soft surfaces and extra flesh of a sofa that has lost its shameless turgidity are the sign of a lasting and mature elegance.

Solid poplar, poplar plywood and birch plywood internal frame. Elastic support straps, polyurethane core, dacron lining coupled with cover material, with covers in cotton velvet, aniline leather or customer fabric, down-filled seat cushions.





From terminal pieces to angular modules to ottomans, Big Bubble offers a full vocabulary of sectional elements to create a multitude of compositions and to adapt to every space and environment. The additional possibility to customize any of the elements makes Big Bubble a truly and universally adaptable system.



## Big Game

Big Game is inspired by a specific old sofa, classically sober in its lines, open in its volumes and comfortable in a contemporary sense because of the break-down of the internal filling and spring structure. We kept the original proportions of the prototype while changing the height, the seating angle, the inside filling, the skin and the stitching, both technically and aesthetically. This deconstruction process further increases the sofa's softness and overall aged character while paradoxically neutralizing the antiquity of the prototype.

Solid poplar frame, helical metal coil springs, polyurethane core, dacron lining coupled with the cover material, with covers in cotton velvet, aniline leather or customer fabric, down-filled seat cushions.



## **Nova** lounge chair

Nova is a light-weight textile lounge chair with a precious look and a fully removable fabric cover. The internal structure is a minimal metal tube skeleton that supports the elastic straps and the polyurethane cushions and that determines the form of the upholstered chair. A fully textile look combined with physical and visual lightness and the possibility to remove the cover, through four zippers located under the seat, are the characteristics of an absolutely unique and original product. Nova is available with or without armrests.

Metal tube structure, elastic support belts, internal cushions in polyurethane, dacron lining, with covers in cotton velvet, Kvadrat Steelcut 2, aniline leather or customer fabric.





## Nova pouf

Nova is a light-weight textile pouf with a precious look and a fully removable fabric cover. The internal structure is a minimal metal tube skeleton that supports the elastic straps and the polyurethane cushions and that determines the form of the upholstered piece. A fully textile look combined with physical and visual lightness and the possibility to remove the cover, through four zippers located under the seat, are the characteristics of an absolutely unique and original product.

Metal tube structure, elastic support belts, internal cushions in polyurethane, dacron lining, with covers in cotton velvet, Kvadrat Steelcut 2, aniline leather or customer fabric.



## Nova two-seater

Nova is family of light-weight textile chairs and armchairs with a precious look and a fully removable fabric cover. A fully textile body combined with physical and visual lightness and the possibility to remove the cover - through four zippers located under the seat - are the characteristics of an absolutely unique and original product. The Nova sofa is a perfect two-seater for smaller spaces: when combined with the armchair and pouf of the same line it creates a full and yet contained living room set.

Metal tube structure, elastic support belts, internal cushions in polyurethane, dacron lining, with covers in cotton velvet, Kvadrat Steelcut 2, aniline leather or customer fabric.

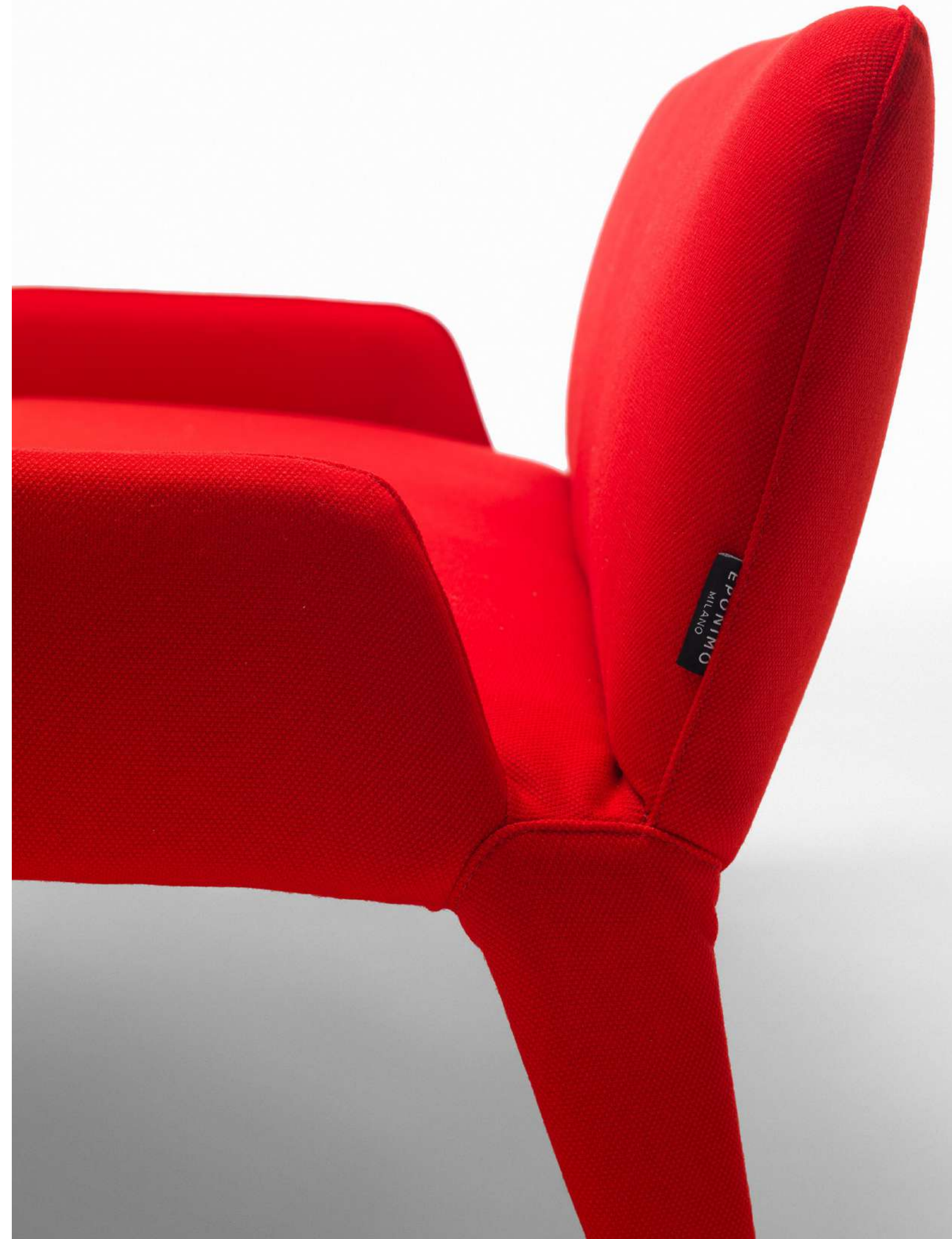



## Gotham armchair

The distinctive linear geometry and the visual lightness of the Gotham sofa come from its metal frame, a clean aerial structure that holds the seat and backrest cushions. These in contrast are generous and voluminous thus creating a visual juxtaposition between the supporting base and the upholstered elements, between structural need and seating comfort. We often upholster the cushions with panno Casentino, the traditional Tuscan wool historically used in the garment industry and introduced by Eponimo into the world of contemporary furniture. A great alternative is our cotton corduroy as the three-dimensional texture of the fabric matches the linear geometry of the armchair's metal structure. The perfect partner for our Gotham armchair is the homonymous ottoman.

Grey cadet painted steel structure, solid oak armrests, polyurethane cushions with covers in casentino wool, cotton velvet, cotton corduroy, anilina leather or customer fabric. Upon request the steel structure can be painted in any other color of the RAL system.



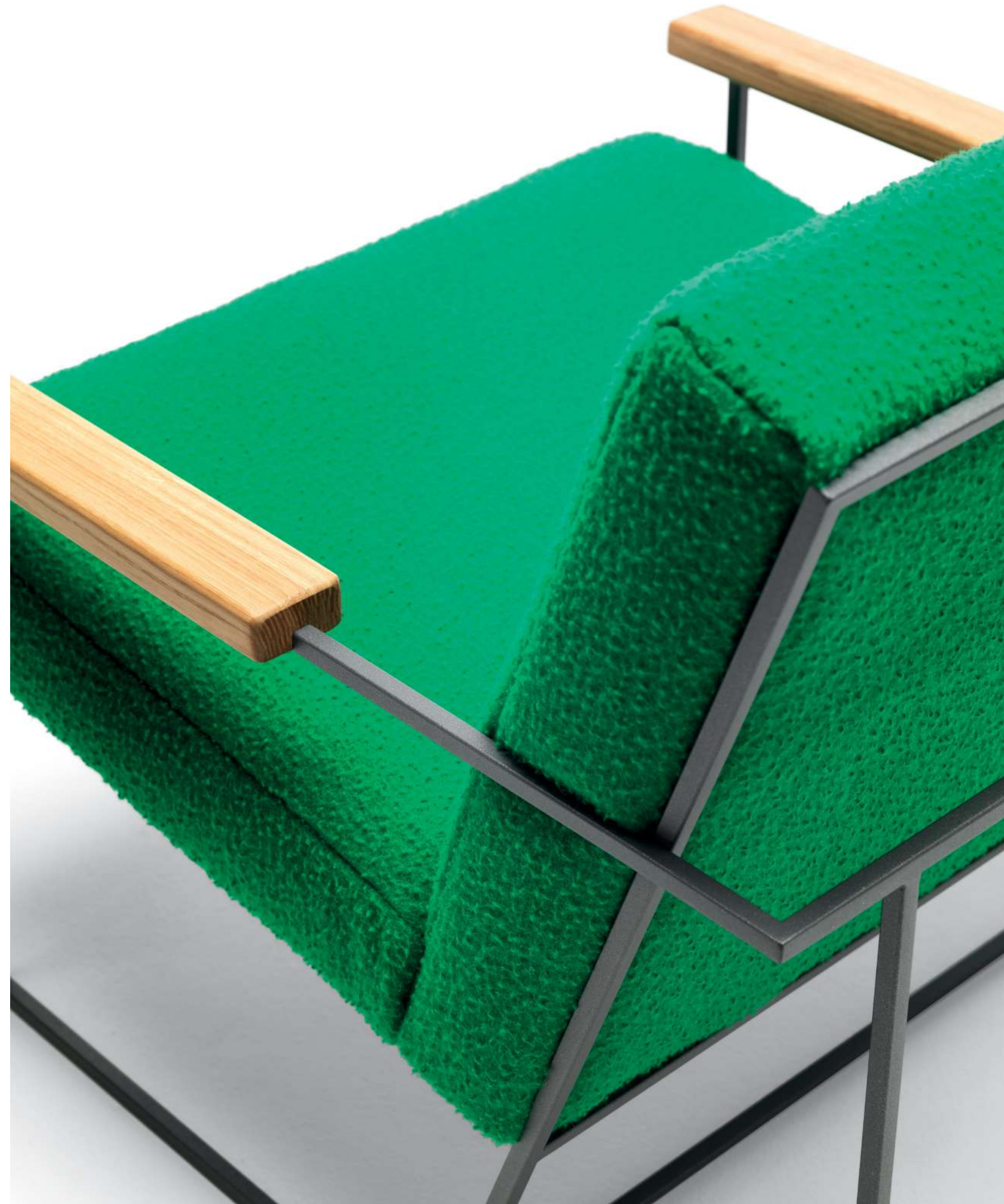

## Gotham two-seater

The distinctive linear geometry and the visual lightness of the Gotham sofa come from its metal frame, a clean aerial structure that holds the seat and backrest cushions. These in contrast are generous and voluminous thus creating a visual juxtaposition between the supporting base and the upholstered elements, between structural need and seating comfort. The Gotham sofa is a perfect two-seater for smaller spaces. Combined with the armchair and pouf of the same line it creates a full and yet contained living room set.

Grey cadet painted steel structure, solid oak armrests, polyurethane cushions with covers in casentino wool, cotton velvet, cotton corduroy, anilina leather or customer fabric. The steel structure can be painted in other colors upon request.





## Exo

The cow-hide in the Exo armchair is both surface and structure. Like in an insect's exoskeleton there is no internal support structure. In both products the polyurethane body is covered with cow-hide panels that once sewn together become structural. The material of the shells and their surfaces are rich but the objects are extremely light. The slight tilt of the armchair's base and the flexibility of the armrests allow for a seating style that follows the movements of the body. Available in 30 colours.

Cow-hide shell, polyurethane core.





## Endo armchair

Endo is a rotating armchair made of thick cow-hide leather, featuring sober lines and rich surfaces. The internal structure is made of steel tubes over which the cow-hide panels are stretched and stitched. There are no internal foam elements or elastic straps thus greatly increasing the sustainability of the product as well as its character: in time the hide will stretch and adapt to the body by matching its form thus making each Endo armchair unique. The steel armrests, perfectly integrated in the design of the armchair, feature a thin solid oak layer to provide for a warmer contact with the body. A swivel base with four spokes and automatic return follows the user's movements and allows for great comfort.

Available in 15 colours. Powder coated steel base and internal frames, cow-hide upholstered elements.





## **Nova** lounge chair

Nova is a light-weight textile chaise longue with a precious look and a fully removable fabric cover. The internal structure is a minimal metal tube skeleton that supports the elastic straps and the polyurethane cushions and that determines the form of the upholstered chair. A fully textile look combined with physical and visual lightness and the possibility to remove the cover, through four zippers located under the seat, are the characteristics of an absolutely unique and original product.

Metal tube structure, elastic support belts, internal cushions in polyurethane, dacron lining, with covers in cotton velvet, Kvadrat Steelcut 2, aniline leather or customer fabric.

## Heritage

It is a contemporary interpretation of a rare Chiavari dormeuse from the XIX century, surprisingly light and original in its forms. To update its design we simplified the lines, we eliminated the decorative lathe work, we used intertwined textile straps for the seat and we chose a black matte finish. The dormeuse is still completely hand-made.

Solid maple wood painted matte black with teal coloured fabric straps seat. Other finishes and colours available upon request.



## Gotham small armchair

It's the younger sister of our homonymous armchair and while it shares the same aesthetic and constructive principles it introduces two new elements to the formal language of the Gotham family: a curved metal structure and "exaggerated" upholstered elements. These give the small armchair an inviting and playful character while maintaining the same visual juxtaposition that is the signature feature of all Gotham seats. An intended visual contrast that is further enhanced by the solid oak armrests: in addition to providing an important ergonomic function they introduce yet another material and formal language.





We can upholster our Gotham small armchair with practically any fabric but panno Casentino - the traditional Tuscan wool historically used in the garment industry and introduced by Epònimo to the world of contemporary furniture - and cotton corduroy truly complement the chair's character. We also color-coordinate the steel structure, sometime to match the fabric's color and sometime to create another harmonious contrast. Despite the much-reduced overall dimensions the Gotham small armchair retains great seating comfort.

Painted steel structure, solid oak armrests and polyurethane cushions with covers in Casentino wool, cotton corduroy, cotton velvet, leather or customer fabric.



## **Nova** small armchair

The Nova small armchair is the latest addition to the homonymous family of products. It is a light-weight textile armchair with a precious look and a fully removable fabric cover. The internal structure is a minimal metal rod skeleton that supports the elastic straps and the polyurethane cushions and that determines the form of the upholstered chair. A fully textile look combined with physical and visual lightness and the possibility to remove the cover - through four zippers located under the seat - are the characteristics of an absolutely unique and original product.

Metal tube structure, elastic support belts, internal cushions in polyurethane, dacron lining, with covers in cotton velvet, Kvadrat Steelcut 2, aniline leather or customer fabric.



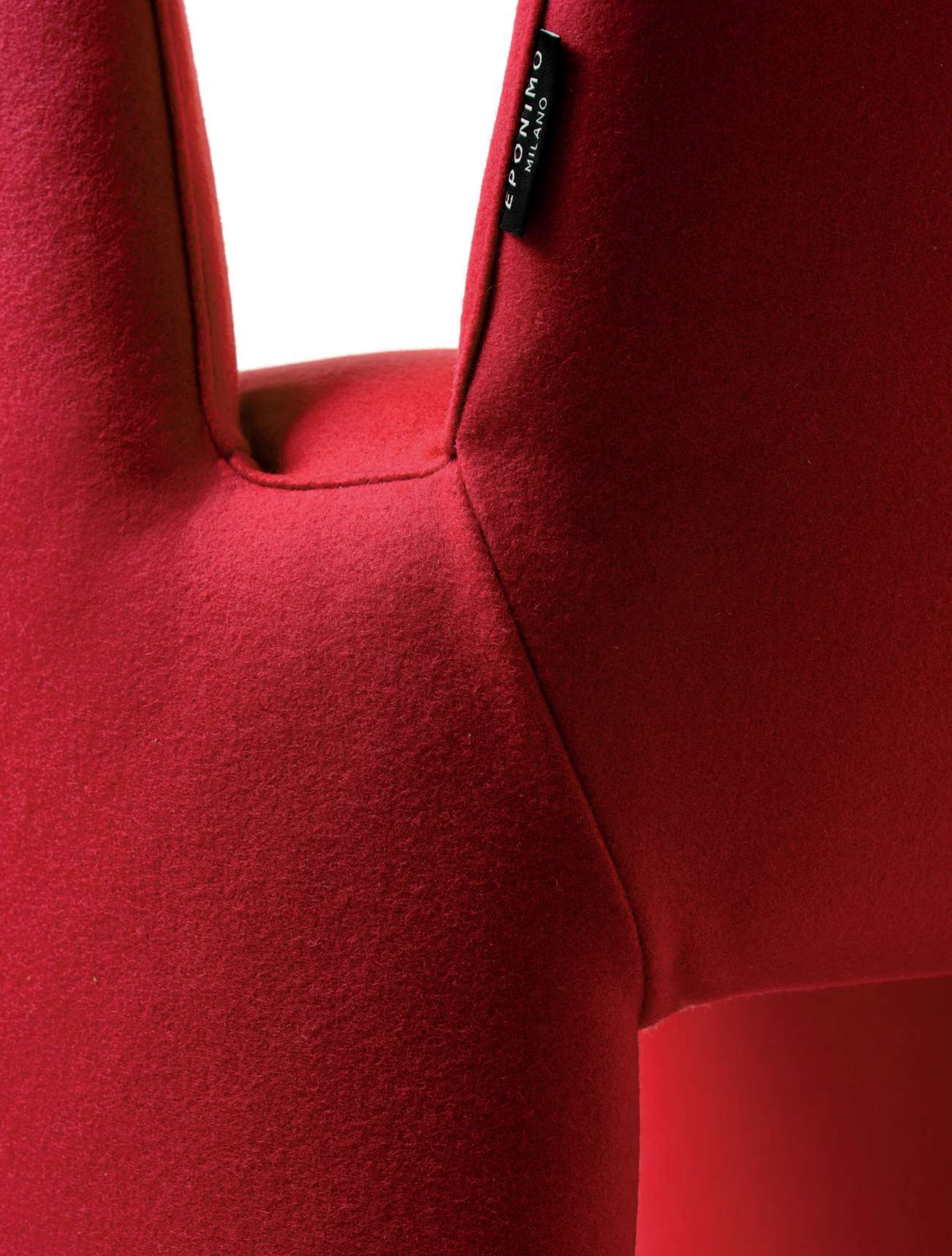

## OW

OW features a fully removable cover and 4 mono-directional wheels - to easily slide under a table and away from it - making it the perfect dining and conference room armchair.

Metal tube structure, elastic support belts, internal cushions in polyurethane, dacron lining, with covers in cotton velvet, Kvadrat Steelcut 2 and Divina, anilina leather or customer fabric.



## **Medven** small armchair

Medven is a textile armchair made of multiple steel frames that are individually upholstered and then assembled. The deliberately abundant cover and the soft internal filling give the armchair an informal and inviting character. Medven features four casters for increased mobility and versatility of use.

Steel structure, elastic support straps, polyurethane cushions, dacron lining, with covers in aniline leather, cotton corduroy or customer fabric.



## Medven two-seater

Medven 2-seater is made of multiple steel frames that are individually upholstered and then assembled. The deliberately abundant cover and the soft internal filling give the armchair an informal and inviting character. Medven features four casters for increased mobility and versatility of use.

Steel structure, elastic support straps, polyurethane cushions, dacron lining, with covers in aniline leather, cotton corduroy or customer fabric.



## “O”

“O” is made of multiple cow-hide panels sewn over steel frames. It’s an intelligent manufacturing technique re-invented here through an original and contemporary design. When seen from above the seat is a square inscribed in the circle defined by the backrest and armrests. Thanks to the plastic nature of cow-hide, this rigorous geometry when developed in space becomes a fluid and functional harmonic language. “O” is available in 30 colours.

Steel structure, cow-hide cover, fabric-covered polyurethane pillow.





## New Outline

Outline was developed by maximizing the integration of form and function while using minimum material. The steel rod frames define a contour that is slender and light, becoming armrests and backrest through a simple and fluid line. The fully removable seat pan and backrest are made of rich cow-hide. Hidden elastic belts allow them to flex with the weight of the body without stretching thus preventing them from losing their shape and structural property. Familiarity and innovation.

Cadet gray or black painted steel structure. Cow hide seat and backrest (20 colors available) with internal elastic support straps.

## Nova chair

Nova is a light-weight textile chair with a precious look and a fully removable fabric cover. The internal structure is a minimal metal skeleton that supports the elastic straps and the polyurethane cushions and that determines the form of the upholstered chair. A fully textile look combined with physical and visual lightness and the possibility to remove the cover - through four zippers located under the seat - are the characteristics of an absolutely unique and original product. Nova is available with or without armrests.

Metal tube structure, elastic support belts, internal cushions in polyurethane, dacron lining, with covers in cotton velvet, Kvadrat Steelcut 2, aniline leather or customer fabric.





The Nova chair with armrests: for the head of the dining table or by itself for additional comfort. Still extremely light and slender. Remarkably even in this version Nova's cover is fully removable.





## Nua

Nua is extremely light, comfortable, visually striking and stackable. The metal structure was developed using the principle of the trestle where each welded steel-rod segment contributes to the overall rigidity and equilibrium of the assembly. Comfort is provided by two cushions held in place by the geometry of the structure without the need for any type of fastening element. Nua champions a philosophy of economy of material where the visual expression of a physical principle translates directly into the form of the final product.

Structure made of painted steel rods in black, red or white. Polyurethane-filled cushions with covers in Kvadrat Steelcut 2 or customer fabric.



## Bic

Bic chair is made by a single metal assembly that supports the upholstered seat and holds the legs and the backrest. The use of different materials in the parts of the chair allows us to take full advantage of their structural properties and their surface qualities: the tactile richness of solid wood for the backrest, the softness of foam for the seat, the rigidity of metal in the supporting structure and the durability of the unpainted natural finish in the solid-wood legs.

Painted steel structure, solid wood legs and backrest, cotton velvet or leather upholstered seat with elastic support belts and polyurethane cushion.





## Aluchair

Aluchair features the form of the archetypal wooden chair but it is made of solid metal: the body is created by mechanically joining two cleverly folded sheets of aluminium. We offer Aluchair with a shiny, polished, mirror-like surface or with a semi-gloss powder coated finish. Four small aluminium cylinders complete the legs and house the rubber feet, making Aluchair extremely quiet despite its full aluminium body. Aluchair is simple and light and yet precious and comfortable.

Alluminium body, rubber feet. Available in RAL grey blue 5008, traffic red 3020, pale green 6021 or polished alluminium finish.



Aluchair is available with a semi-gloss powder coated colored finish, in red, green and blue. Other colors are available upon request.





## Alustool

Alustool is a minimalist bar stool, combining geometric lines and precious details. It evolves from the homonymous chair: the body is created by mechanically joining two cleverly folded sheets of aluminum. Four small cylinders house the rubber feet, making the stool extremely quiet despite its full aluminum body. An additional thin bar with a brushed finish acts as a footrest and protects the surface of the stool. A removable cushion provides additional comfort and insulates the body from the metallic seat. Alustool is clean and light and yet elegant and comfortable.

Bent and cut aluminum plate body, rubber feet. Available in all RAL colors with a semi-gloss powder coated finish.



## Rock table

A 4-legged table completely made of stone. Through a simple trick the table, which is in fact the assembly of five parts, appears sculpted from a solid block. The four lateral elements, once they are assembled with the top, become structural without the need for additional parts that would in turn compromise the sculptural effect of the piece. The surface of the table is treated with a slightly three-dimensional weathered finish that further increases the preciousness and uniqueness of the natural material and that in time hides potential scratches and stains.

White Carrara, black New Saint Laurent or Cipollino marble. Weathered finish. Other stones and finishes are available upon request.



## Wood table

A 4-legged table made of MDF finished with blue stained eucalyptus veneer. Through a simple trick the table, which is in fact the assembly of five parts, appears sculpted from a solid block. The four lateral elements, once they are assembled with the top, become structural without the need for additional parts that would in turn compromise the sculptural effect of the piece. The proportions of our Wood table, inspired by the traditional *fratine*, enhance the perception of its length and the intimacy among diners.

MDF, blue eucalyptus veneer. Other veneers are available upon request.



## Nadi table

The project re-interprets the structure of an antique table, large but extremely light, through an aesthetic gesture that enhances the age and at the same time the modernity of the piece. The glass top reveals the skeleton of the support, typically hidden by a solid top. The contrast between inside and outside, between light and dark, becomes the aesthetic theme, expressed through the use of two different woods (mahogany and larch) and two different finishes. The glass top creates a showcase-like effect and becomes a window to the history of the table.

Solid black-stained mahogany external structure, natural solid larch internal structure, tempered glass top. Other finishes and colours available upon request.



## Roll table

Roll is Epònimo's central stem dining table. The base, carved from a single block of marble, is a geometric and yet organic sculpture that changes dramatically when viewed from different angles. Functionally it supports a thick but clear glass top which maintains a perfect visual balance with the marble volume below without hindering the view of it. With our standard glass top our Roll table seats 8 people.

New Saint Laurent marble and 15mm extra-clear tempered glass. Other stones are available upon request.





## Big Sur desk

An original desk with a wooden top and a glass extension that can rotate around a central pivoting point, like the hand of a clock. This allows the table to expand and contract its usable surface and to adapt to different uses: a dedicated support for a printer or other peripherals, a smaller desk for an additional person or simply more tabletop space. Both tops are supported by a light and essential structure made of copper tubing: the rich warm metal of the base plays beautifully against the natural surface of the wood and the transparency of the glass. The wooden top fits onto the base through four cut-outs that hold it firmly in place. The glass top is also held in place by three circular cut-outs that grab onto the copper structure.

Internal steel structure, external copper tubing, top in oak-veneered MDF, rotating extension in 15 mm float glass.

## Rock low table

A 4-legged coffee table completely made of stone. Through a simple trick the table, which is in fact the assembly of five parts, appears sculpted from a solid block. The four lateral elements, once they are assembled with the top, become structural without the need for additional parts that would in turn compromise the sculptural effect of the piece. The surface of the table is treated with a slightly three-dimensional weathered finish that further increases the preciousness and uniqueness of the natural material and that in time hides potential scratches and stains.

Carrara, New Saint Laurent, Sahara Noir or Cipollino marble. Weathered finish. Other stones and finishes are available upon request.







## Ghost low table

A 4-legged low table completely made of glass, Ghost is the transparent version of our best-selling Rock low table and it shares the same original sculptural detail. But while the marble version creates the illusion of a table sculpted out of a solid piece of stone, Ghost reveals its construction through the transparency of glass. Surprisingly this clarity only adds to the magic of the piece which becomes extremely ethereal. As one moves around the table its lines and details are revealed and hidden in an ongoing optical play.

Float glass.





## Wood low table

A 4-legged low table made of MDF finished with blue stained eucalyptus veneer. Through a simple trick the table, which is in fact the assembly of five parts, appears sculpted from a solid block. The four lateral elements, once they are assembled with the top, become structural without the need for additional parts that would in turn compromise the sculptural effect of the piece.

MDF, blue eucalyptus veneer. Other veneers are available upon request.





## Roll low table

Roll low table is a sculptural solid marble piece. Its geometric and yet plastic and organic form changes dramatically when viewed from different angles. Roll is also extremely functional: its cylindrical essential volume will fit a multitude of environments. The internal cavity serves as storage space for pillows, books, magazines, etc. The top surface features a raised lip to safely prevent objects from falling or sliding off.

New Saint Laurent or Carrara marble. Other stones are available upon request.





## Big Sur low table

An elegant low table with two tops that can rotate around a central pivoting point, like the hands of a clock. This allows the table to modify its usable surface and to adapt to different uses and spaces. The opposite curves of the two asymmetrical elliptical tops create a sinuous flow that visually holds them together. They are supported by a light and essential structure made of copper tubing: the rich warm metal of the base plays beautifully against the natural surface of the stone or the saturated but translucent glass tops.

Internal steel structure, external copper tubing, tops in back-painted glass (all RAL colors available), marble (white Carrara, green/gray Cipollino, black New Saint Laurent) or quartzite (green Bamboo).



## MT low table

The MT coffee table is at once simple and rich. The base is made with a very thin squared metal tubing which results in physically and visually light and clean geometric structure. The oval top is thick solid marble made visually lighter by a bevelled edge. Available in 2 heights.

Grey cadet painted steel structure with marble top in New Saint Laurent, Carrara or Cipollino marble. Other stones are available upon request.



## Bic low table

In our Bic coffee table a central aluminum frame supports the top and holds the legs, both made of marble. The resulting visual effect is that of a solid stone piece held tight by a minimalist and geometric metal crown. The marble of the top, with its colors, veins and pattern, reappears below the frame in the legs as if these were pouring from the flat upper surface in a fluid liquid-like way. The legs – that would otherwise be quite fragile and not structural - are in fact held in place by an internal steel rod connected to the metal frame. A simple structural trick that allows for the visual magic of thin conical marble legs.

Painted aluminum structure, solid marble top and legs. Matte honed finish. Available in green Verde Alpi, black New Saint Laurent or white Carrara marble with matching aluminum frame.



## Toid side table

Toid is a one-piece solid-bronze sand-cast side table. The lower portion is coated with liquid wax and then flame-treated to obtain an extremely rich and warm finish, while the top surface is polished to an almost mirror finish. This process, completely done by hand by foundry master artisans near Milano, reveals the two opposing material qualities of bronze: a dark and deep outer skin that turns into a warm shining golden surface when polished. The solarized stain that naturally develops in the middle of the round top during the manufacturing process is purposefully preserved as a precious signature detail for the piece.

Solid sand-cast bronze.







## Rock side table

A 4-legged side table completely made of stone. Through a simple trick the piece, which is in fact the assembly of five parts, appears sculpted from a solid block. The four lateral elements, once they are assembled with the top, become structural without the need for additional parts that would in turn compromise the sculptural effect of the piece. The surface is finished with a light three-dimensional weathered finish that further increases the preciousness of the natural material and that in time hides potential scratches and stains. Available in two sizes.

White Carrara or black New Saint Laurent marble. Weathered finish. Other stones and finishes are available upon request.



## Rock nightstand

A bedside table completely made of stone. Through a simple trick the piece, which is in fact the assembly of five parts, appears sculpted from a solid block. Rock can be positioned in two different ways: showing its two “blind” sides thus keeping the content of its lower shelf hidden and private, or showing its 2 open sides, thus offering open access and view to the lower shelf. The surface is finished with a light three-dimensional weathered finish that further increases the preciousness of the natural material and that in time hides potential scratches and stains.

White Carrara or black New Saint Laurent marble. Matte honed finish. Other stones and finishes are available upon request.



## Wood side table

A 4-legged side table made of MDF finished with blue stained eucalyptus veneer. Through a simple trick the table, which is in fact the assembly of five parts, appears sculpted from a solid block. The four lateral elements, once they are assembled with the top, become structural without the need for additional parts that would in turn compromise the sculptural effect of the piece. Available in two heights.

MDF, blue eucalyptus veneer. Other veneers are available upon request.





## Roll side table

Our Roll side table is obtained from the “waste” material that is generated in the manufacturing process of our larger dining table: when we produce it we core out the base by extracting two identical cylinders; with these we produce as many Roll side tables. They are in fact identical scaled-down copies of the dining table but instead of supporting a glass-top they feature a carved lip on the top surface to safely prevent objects from falling or sliding off.

New Saint Laurent marble. Other stones are available upon request.





## MT side table

The MT sidetable is simple and rich at the same time. The base is made with a very thin squared metal tubing which results in physically and visually light and clean geometric structure. The circular top is thick solid marble made visually lighter by a bevelled edge. Available in 2 heights.

Grey cadet painted steel structure with marble top in New Saint Laurent, Carrara, Ceppo di Gré or Cipollino marble. Other stones are available upon request.





116



117



## Long Playing side table

The Long Playing side tables stem from the eponymous étagère and feature the same play of materials: an essential but rich copper structure supporting one or two circular shelves made of back-painted glass. The rich warm metal of the base plays beautifully against the glossy translucent finish of the glass shelves. They are available in 2 sizes.

Internal steel structure, external copper tubing, tops in painted glass (all RAL colors are available).



## Gotham side table

The Gotham side table/nightstand is simple, compact, rich and soft all at once. The base is made with a very thin squared metal tubing which results in a physically and visually light geometric structure. The top is upholstered in velvet to create a surface that is pleasing to the touch and gentler toward fragile items such as smartphones, eyeglasses and watches. Available in 2 sizes.

Grey cadet painted steel structure with upholstered top in cotton velvet. Sixteen colours available.





## New Outline bench

New Outline was developed by maximizing the integration of form and function while using minimum material. The steel rod frame that holds the seat is slender and light. It develops into the side armrests, two barely suggested curves that define the piece. The seat on the other hand is made of rich cow-hide and features a generous thickness. Hidden elastic belts allow it to flex with the weight of the body without stretching thus preventing it from losing its shape and structural property. Familiarity and innovation available in 8 leather colours.

Cow hide seat with internal elastic straps. Black, cadet gray or red painted steel structure. All RAL colours available upon request.



## Gotham bench

A small bench, simple, compact and extremely light, designed to be placed at the end of the bed but versatile enough to go anywhere. The base is made with a very thin squared metal tubing which results in physically and visually light and clean geometric structure. The seating surface is upholstered with shaped polyurethane foam and cotton velvet: minimal but comfortable, colourful and pleasant to touch.

Grey cadet painted steel structure with upholstered top in cotton velvet. Sixteen colours available.





## Long Playing étagère

An essential but rich étagère featuring 3 columns made of copper tubing, each one supporting 5 circular shelves made of back-painted glass. Each column rotates vertically and independently while remaining connected to the next, allowing the etagere to modify its foot-print and to hug curved walls and corners or to gather its 3 columns together to become a more compact free-standing unit. The warm copper structure plays beautifully against the glossy finish of the glass shelves. Additional units can be connected to form extensive bookcases or partitions. Long Playing is also available as a single column.

Internal steel structure, external copper tubing, 15 shelves in painted glass (all RAL colors are available).





## Gotham wardrobe

The Gotham wardrobe merges the functions of a coat hanger and those of a set of shelves. It can be used in the home or in a commercial space to display hanging as well as folded garments. The structure is physically and visually extremely light; it can be moved with no effort. The shelves are upholstered in velvet to create a luxurious surface that is pleasing to the touch and gentler toward fragile and delicate items.

Grey cadet painted steel structure with upholstered top in cotton velvet. Sixteen colours available.

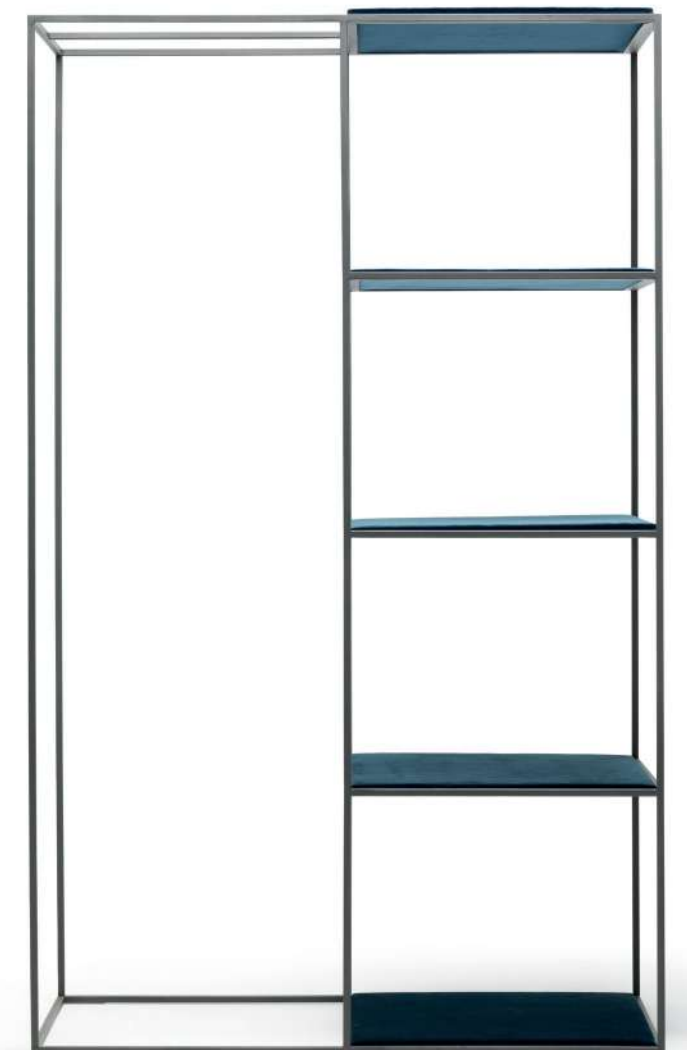

## BIG GAME

Please note: this product's measurements can be adjusted to customer's needs

**BG 001** divano a due posti / two-seater sofa

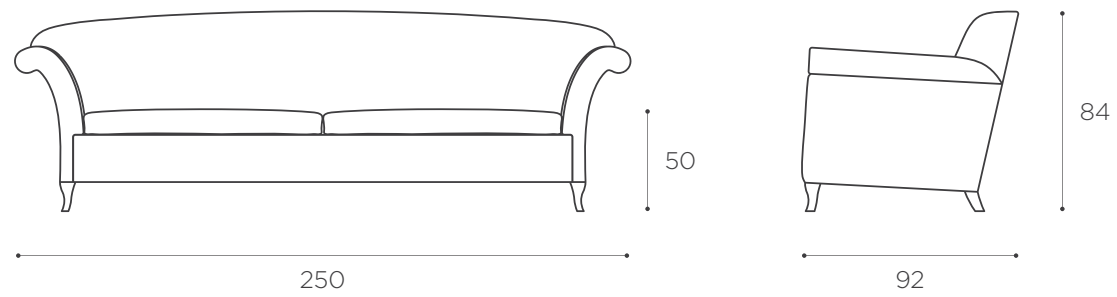

**BG 002** divano a due posti / two-seater sofa

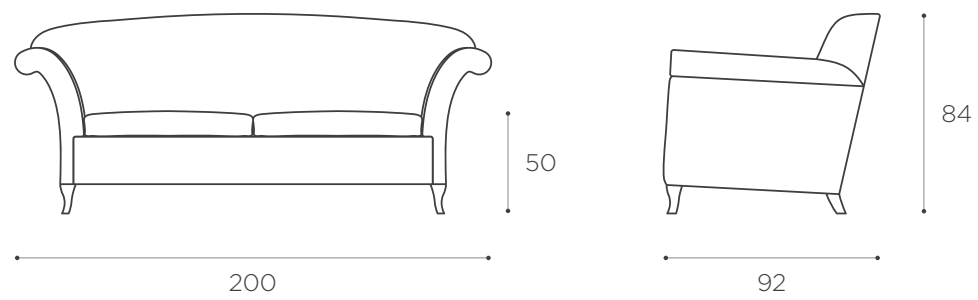

**BG 003** poltrona / armchair

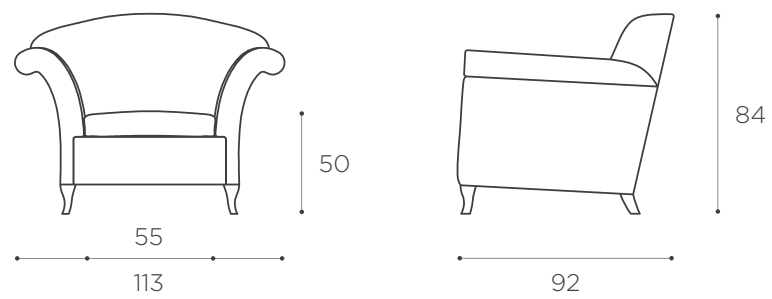

**BG 004** pouf / pouf

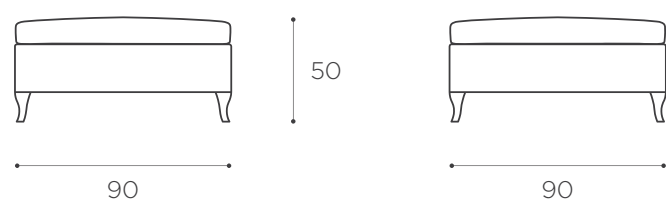

## SEXY BEAST

Please note: this product's measurements can be adjusted to customer's needs

**SB 001** divano a due posti / two-seater sofa

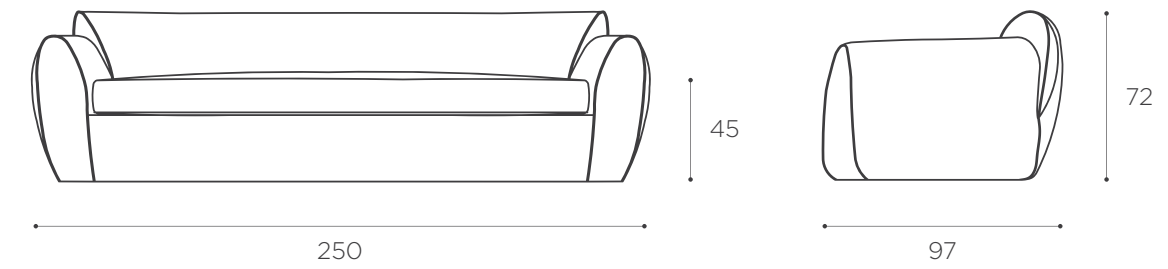

**SB 002** divano a due posti / two-seater sofa

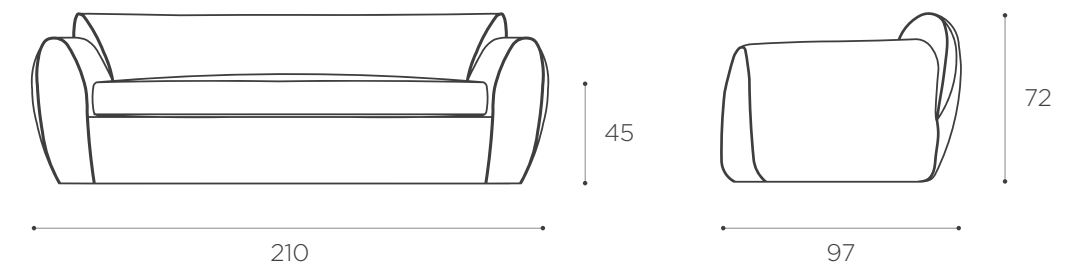

**SB 003** divano a due posti / two-seater sofa

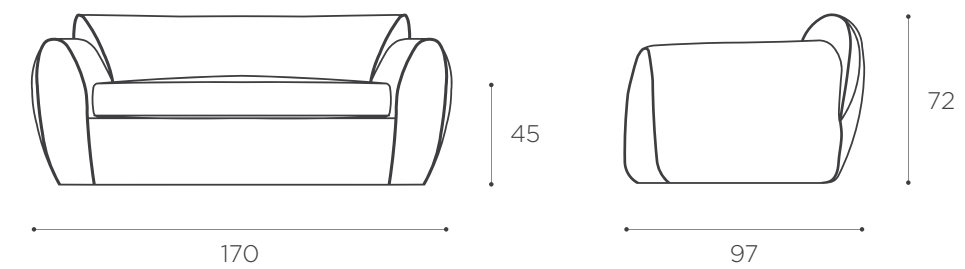

**SB 004** poltrona / armchair

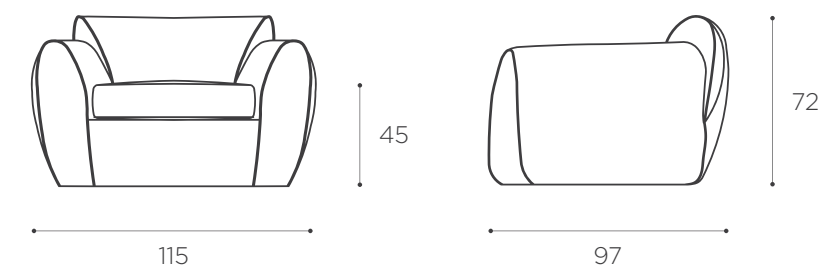

**SB 005** divano a due posti extra profondo / two-seater sofa extra deep

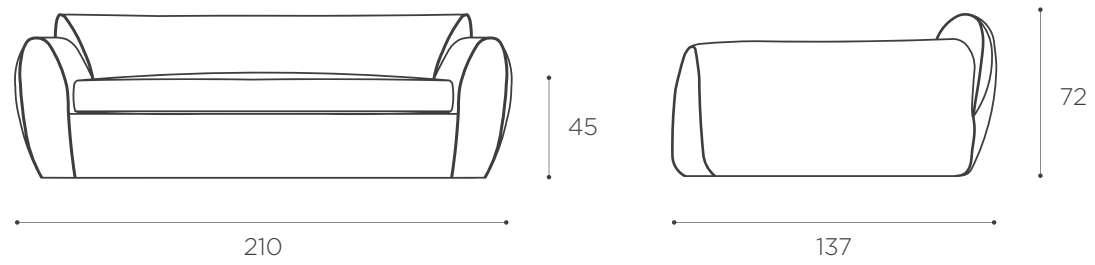

**BIG BUBBLE**

Please note: this product's measurements can be adjusted to customer's needs

**BB 001** divano a tre posti / three-seater sofa

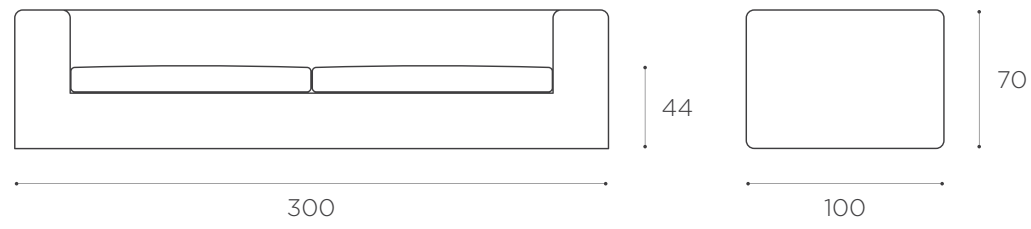

**BB 002** divano a due posti / two-seater sofa

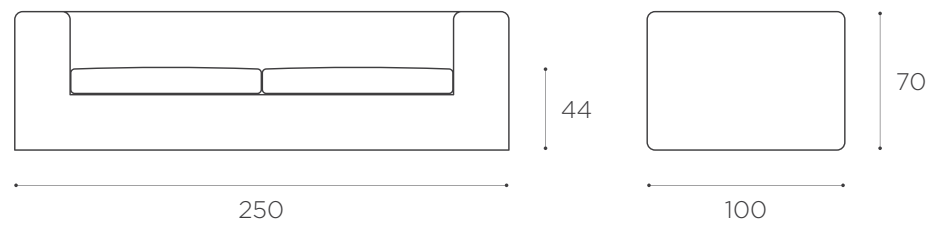

**BB 003** divano a due posti / two-seater sofa

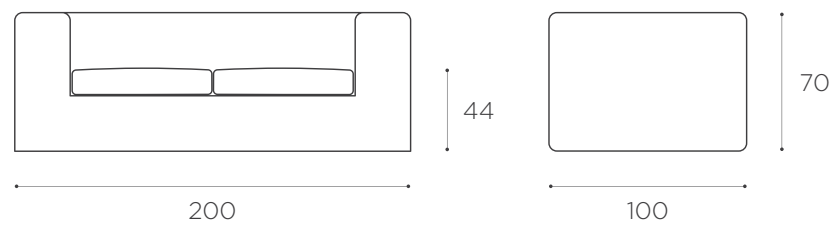

**BB 004** poltrona / armchair

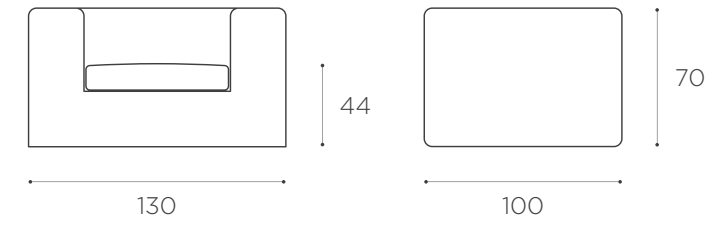

**BB 005** terminale sx - dx / sommier left - right

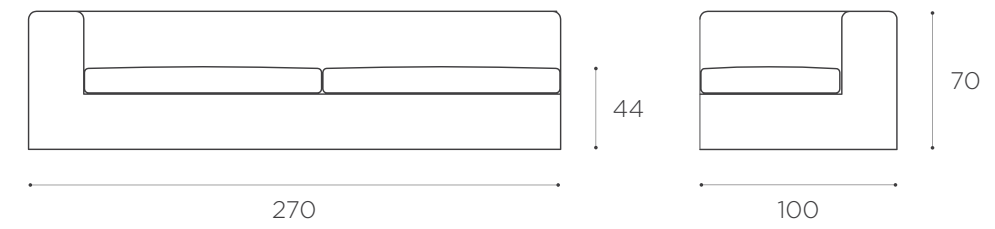

**BB 006** terminale sx - dx / sommier left - right

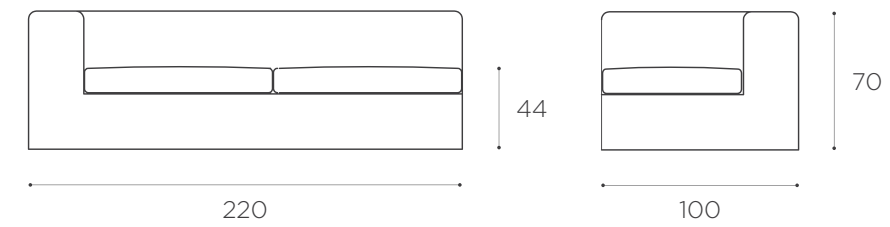

**BB 007** terminale sx - dx / sommier left - right

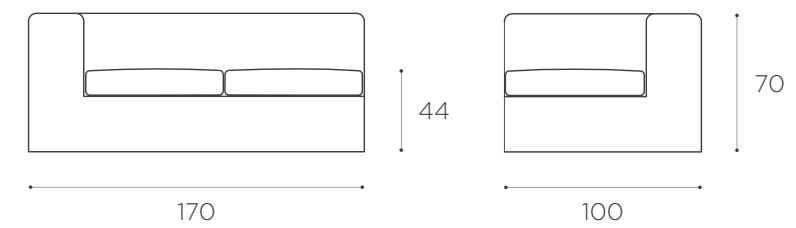

**BB 008** chaise longue sx - dx / chaise longue left - right

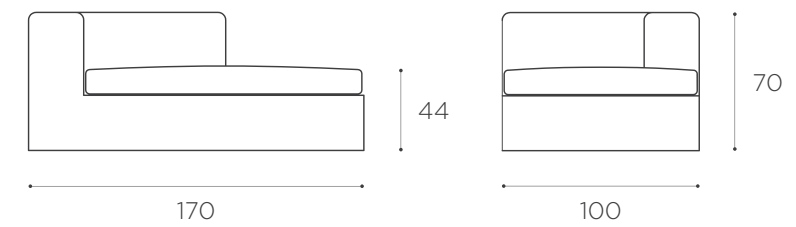

**BB 009** mod. seduta doppio / two-seater module

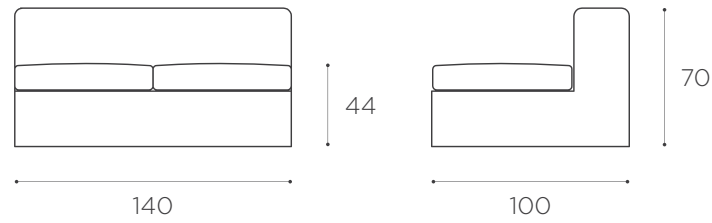

**BB 010** mod. seduta singolo / one-seater module

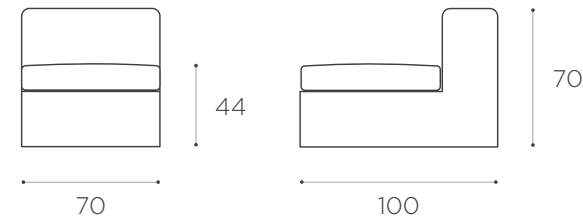

**BB 011** mod. angolare / corner module

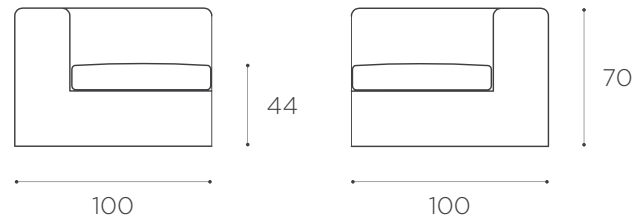

**BB 012** pouf / pouf

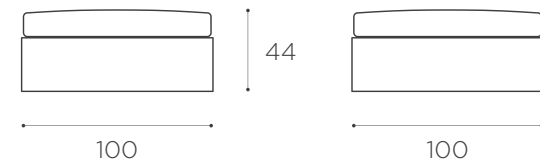

**BB 013** pouf / pouf

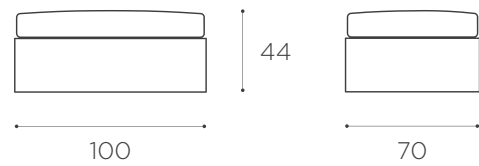

**BB 014** pouf / pouf

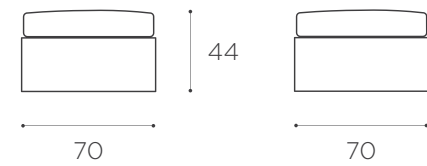

**GOTHAM SEATERS**

**GT 005** divanetto a due posti / two-seater sofa

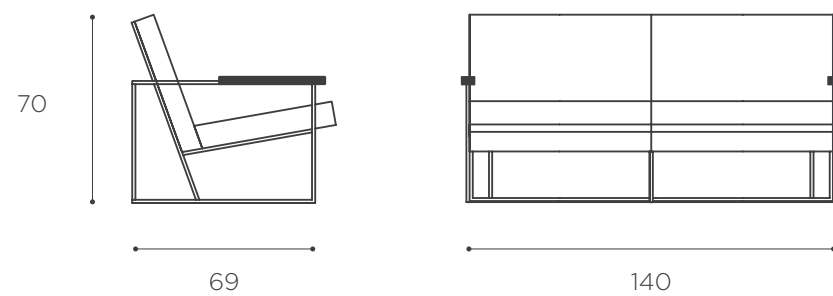

**GT 001** poltrona / armchair

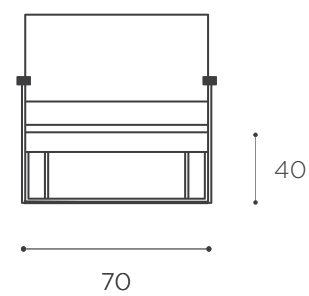

**GT 006** pouf / pouf

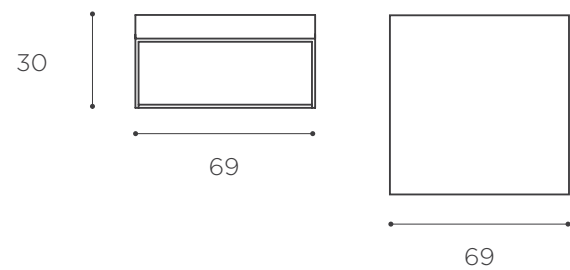

**GT 008** poltroncina / small armchair

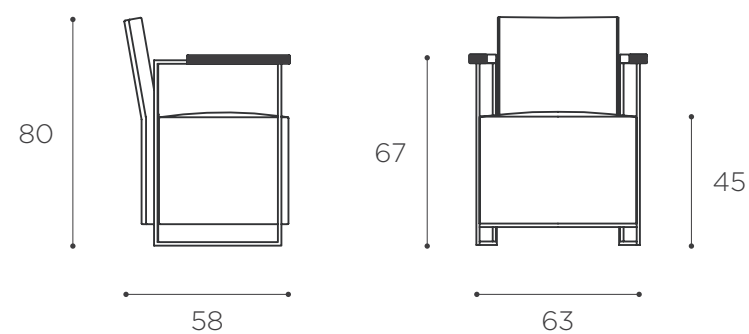

**NOVA SEATERS**

**NV 003** poltrona / lounge chair

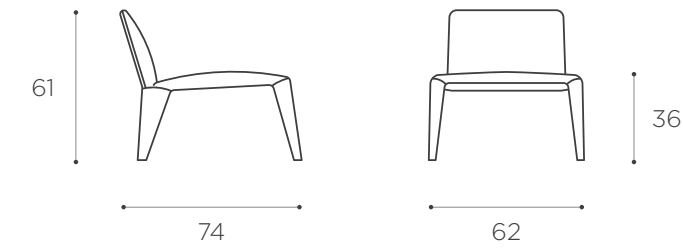

**NV 005** pouf / pouf

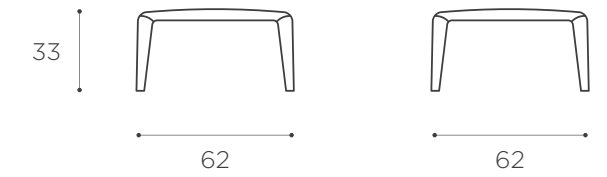

**NV 004** con braccioli / with armrests

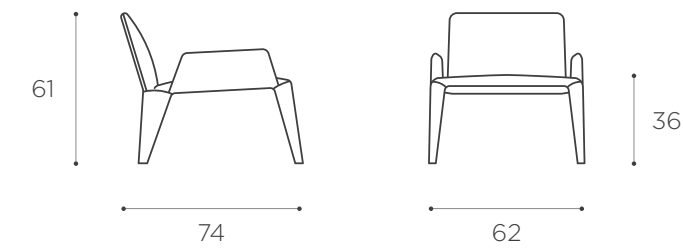

**NV 006** divanetto a due posti / two-seater sofa

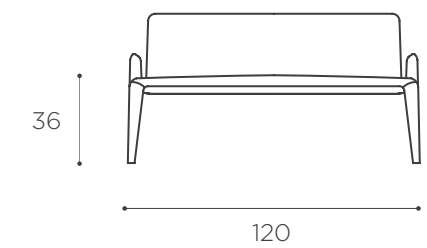

**NOVA SMALL ARMCHAIR**

**NV 008** poltroncina / small armchair

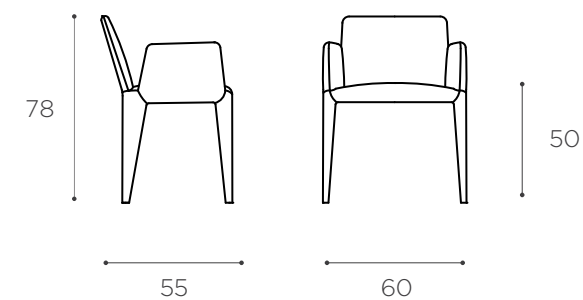

**OW**

**OW 001** poltroncina / small armchair

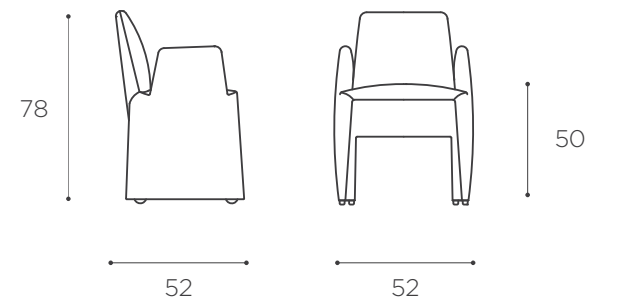

**ENDO**

**EN 001** poltrona / armchair

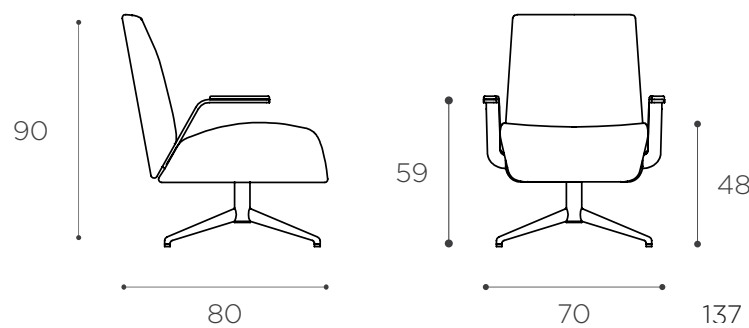

**MEDVEN SEATERS**

**MD 001** poltroncina / small armchair

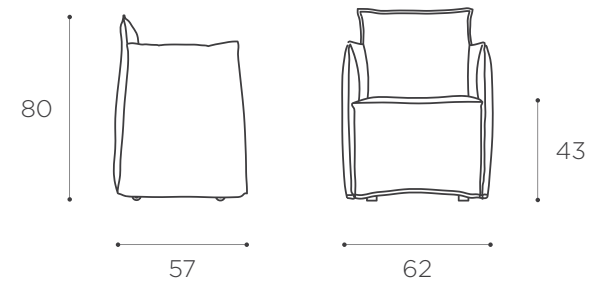

**MD 002** divanetto a due posti / two-seater sofa

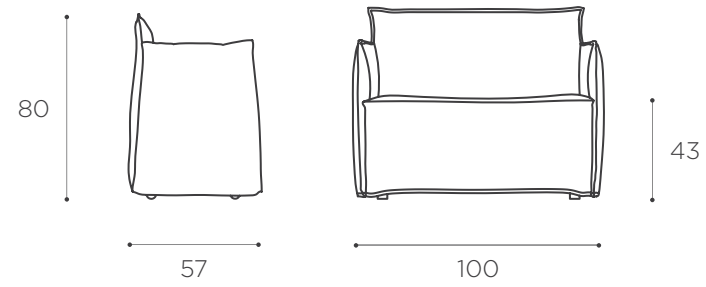

**NOVA CHAIR**

**NV 001** sedia / chair

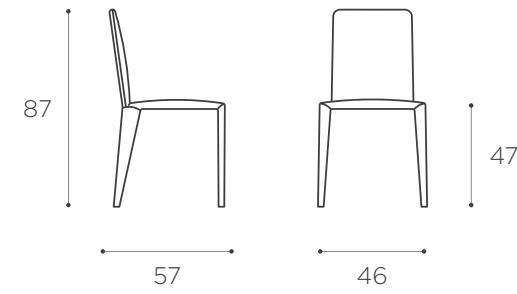

**NV 002** sedia con braccioli / chair with armrests

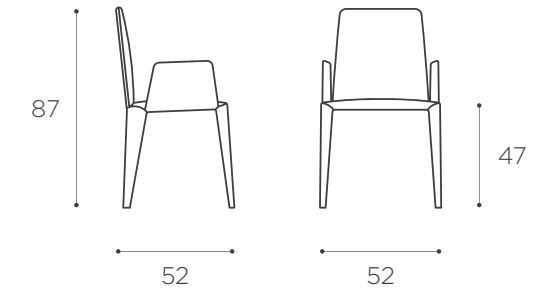

**EXO**

**EX 001** poltrona / armchair

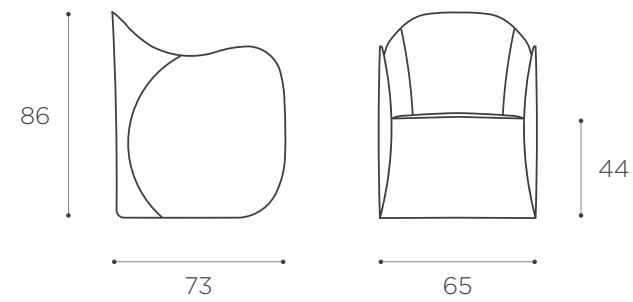

**EX 002** pouf / pouf

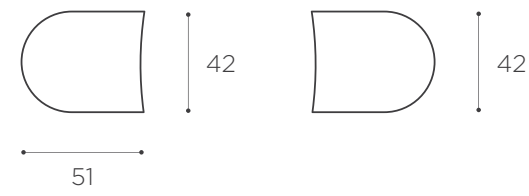

**NEW OUTLINE**

**OL 002** poltroncina / small armchair

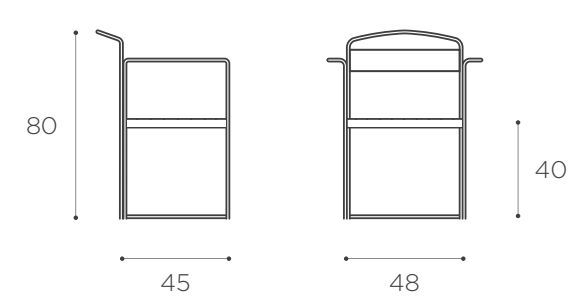

**ALUCHAIR**

**AL 001** sedia / chair

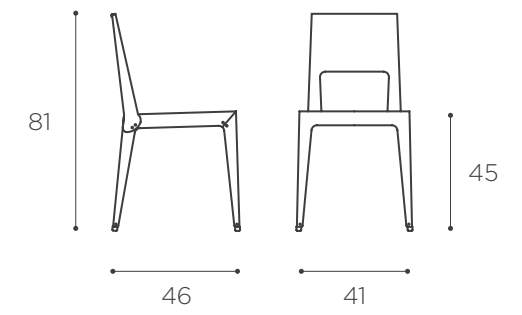

**“O”**

**OO 001** poltroncina / small armchair

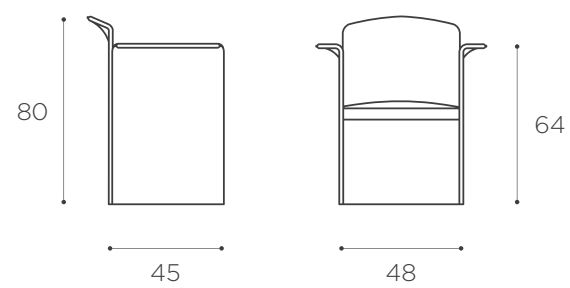

**HERITAGE**

**HE 001** dormeuse / dormeuse

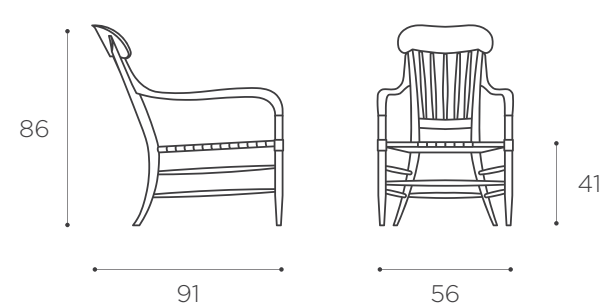

**NUA**

**NU 001** sedia / chair

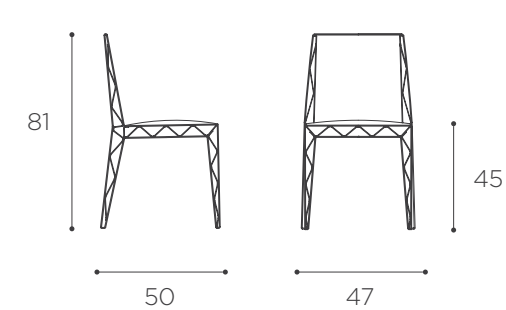

**BIC**

**BC 001** sedia / chair

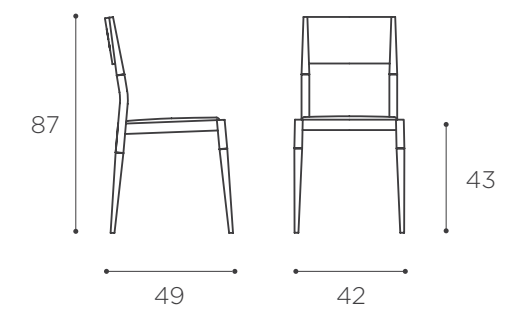

## ROCK TABLE

Please note: this product's measurements can be adjusted to customer's needs

**RK 001** tavolo / table

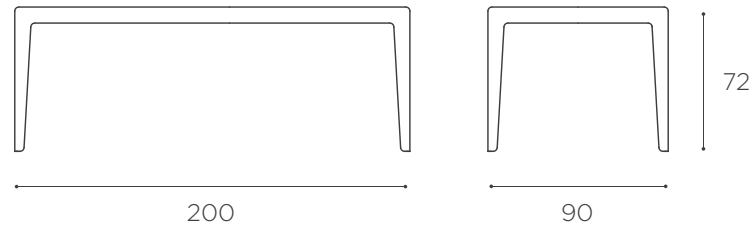

**RK 002** tavolo / table

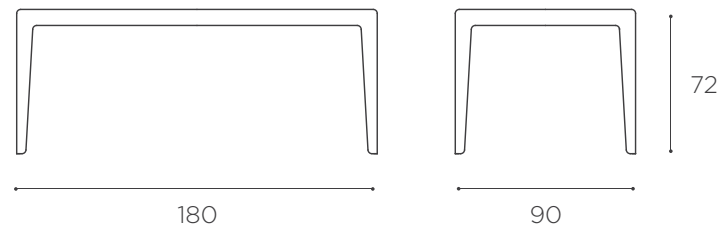

**RK 003** tavolo / table

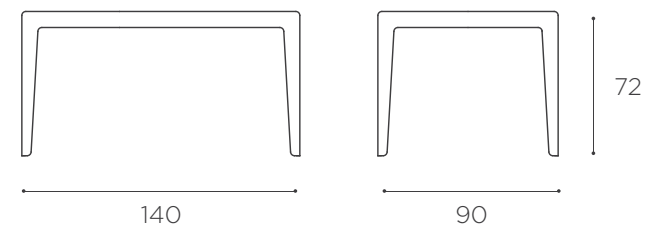

**RK 004** tavolo / table

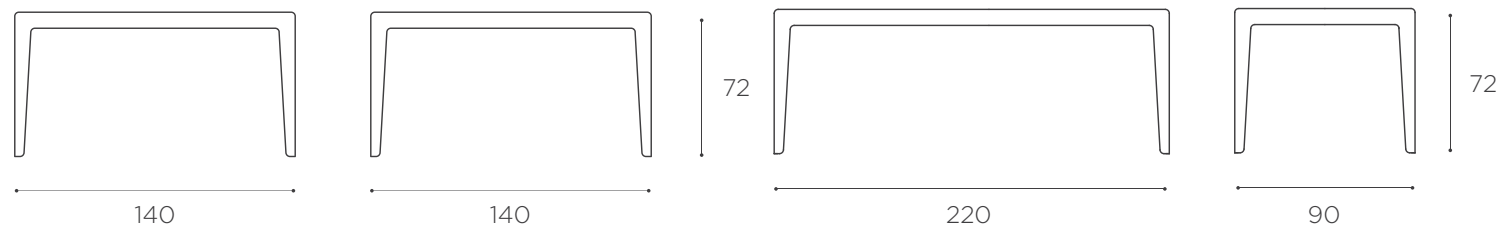

**RK 008** tavolo / table

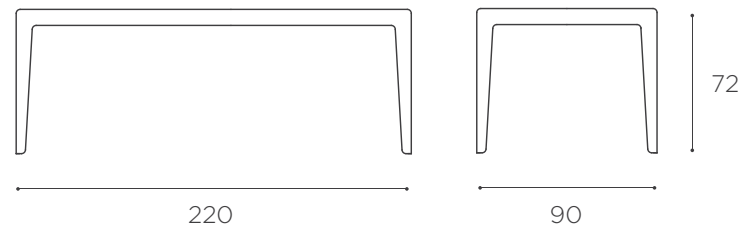

## ROLL TABLE

**RL 001** tavolo / table

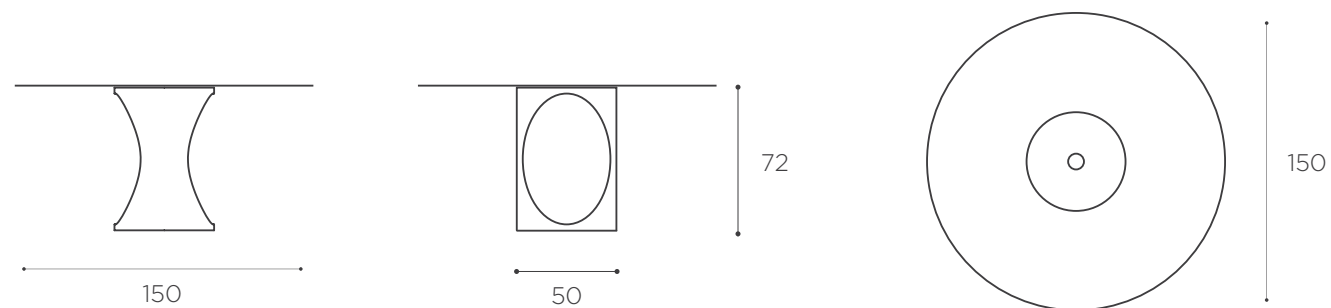

## WOOD TABLE

Please note: this product's measurements can be adjusted to customer's needs

**WD 001** tavolo / table

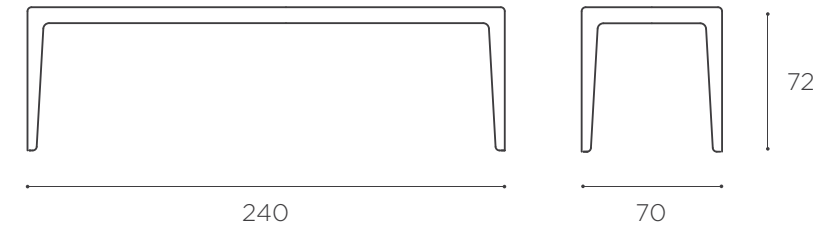

**WD 002** tavolo / table



**WD 003** tavolo / table



**WD 004** tavolo / table



**WD 005** tavolo / table

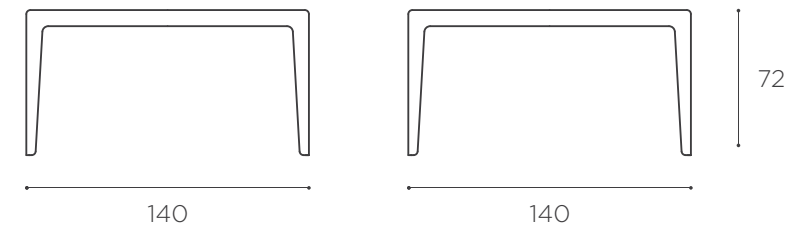

## BIG SUR DESK

**BS 002** scrivania / desk

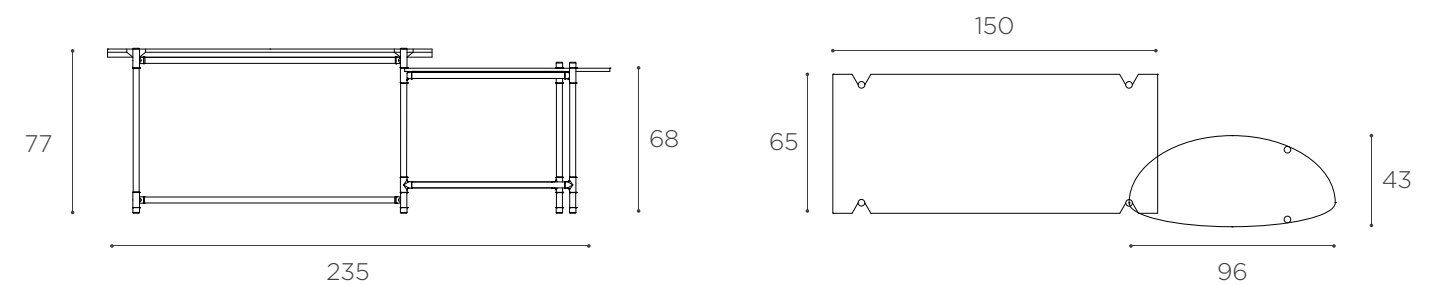

**NADI TABLE**

Please note: this product's measurements can be adjusted to customer's needs

**ND 001** tavolo / table

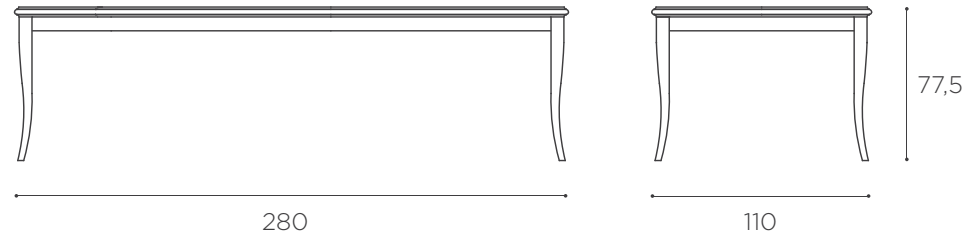

**ND 002** tavolo / table

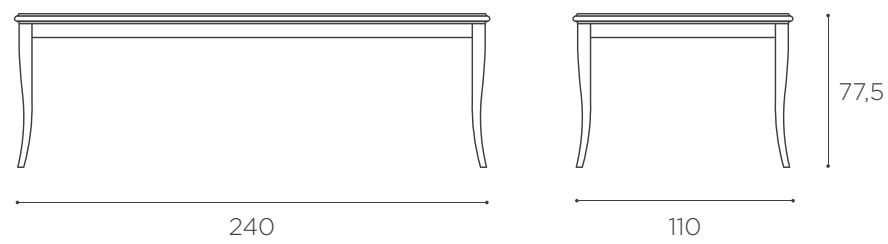

**ND 003** tavolo / table

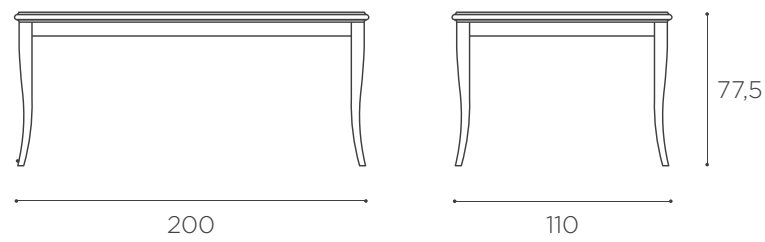

**ND 007** tavolo / table

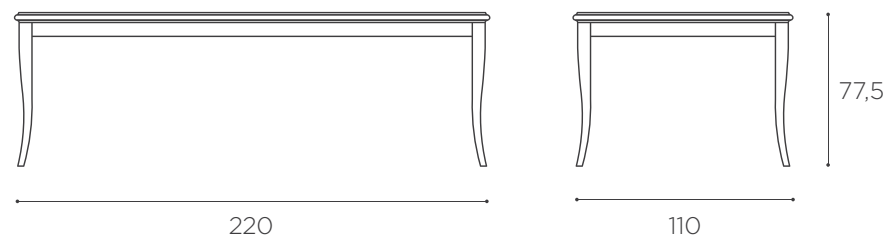

**ROCK LOW TABLE**

**RK 005** tavolino / low table



**GHOST LOW TABLE**

**GH 001** tavolino / low table

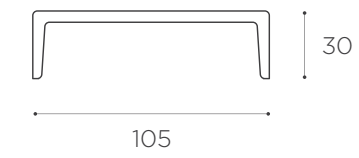

**WOOD LOW TABLE**

**WD 006** tavolino / low table

**BIG SUR LOW TABLE**

**BS 001** tavolino / low table

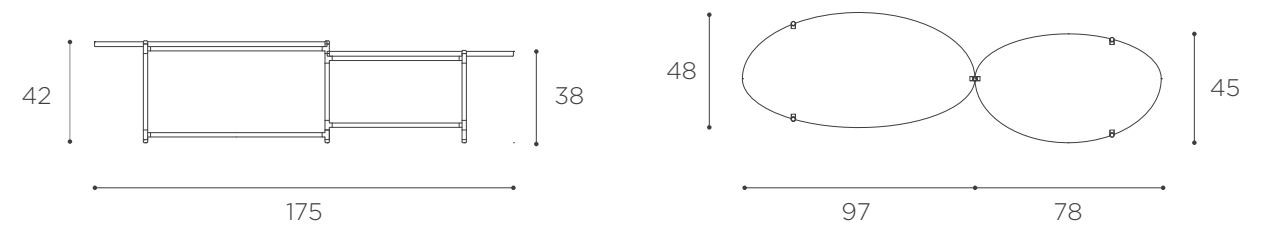

**MT LOW TABLE**

**MT 003** tavolino / low table

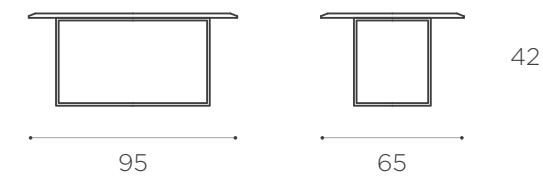

**MT 004** tavolino / low table

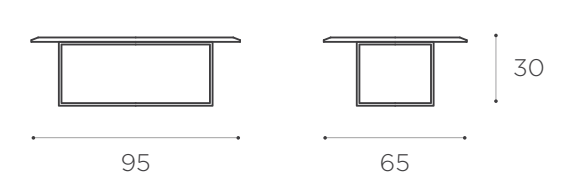

**BIC LOW TABLE**

**BC 002** tavolino / low table

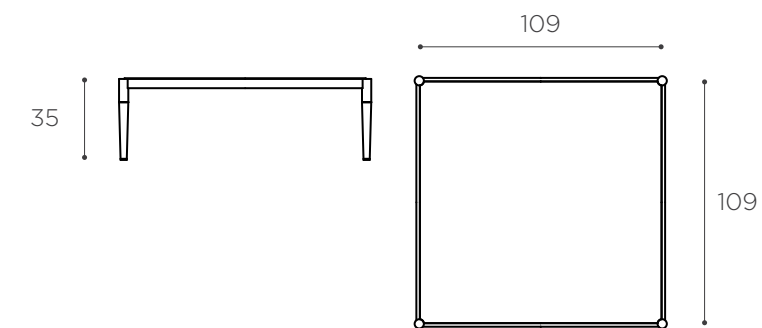

**ROLL LOW TABLE**

**RL 003** tavolino / low table

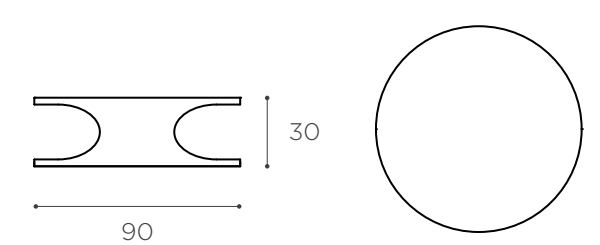

**ROCK SIDE TABLE**

**RK 006** tavolino / side table

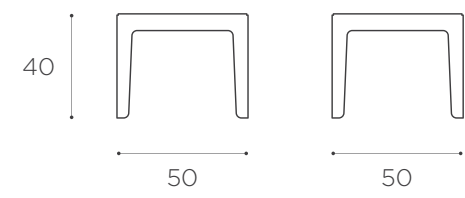

**RK 007** tavolino / side table

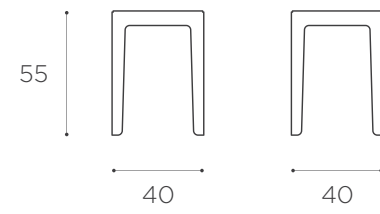

**MT SIDE TABLE**

**MT 001** tavolino / side table

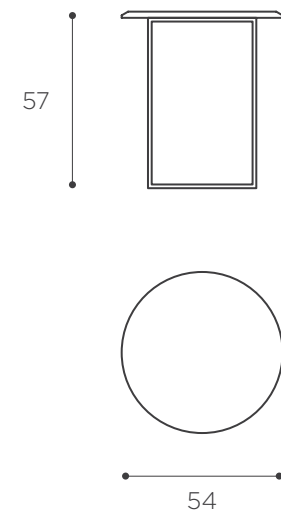

**MT 002** tavolino / side table

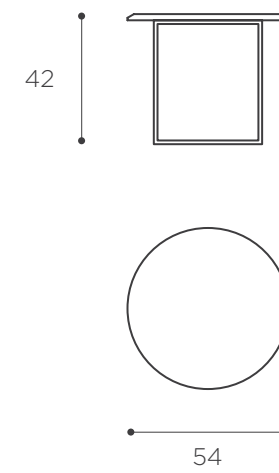

**WOOD SIDE TABLE**

**WD 007** tavolino / side table

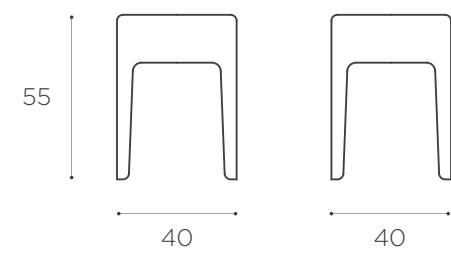

**WD 008** tavolino / side table

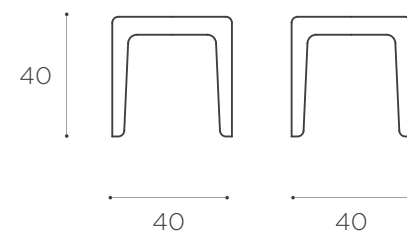

**GOTHAM SIDE TABLE**

**GT 002** tavolino / side table

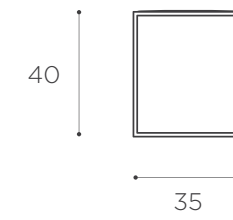

**GT 003** tavolino / side table

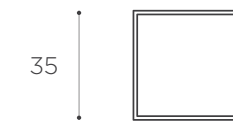
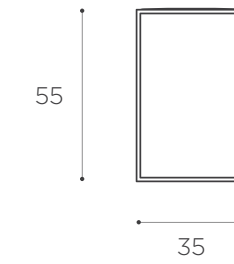

**ROLL SIDE TABLE**

**RL 002** tavolino / side table

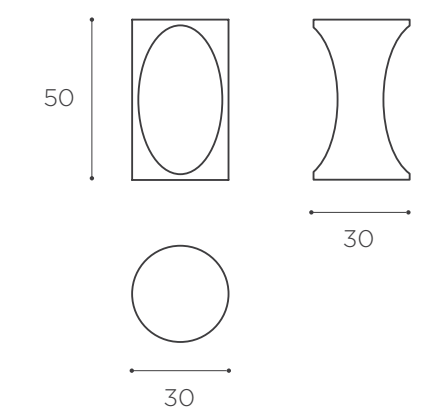

**LONG PLAYING SIDE TABLE**

**LP 003** tavolino / side table

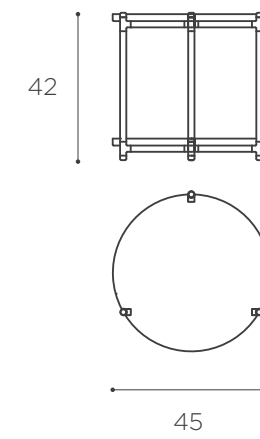

**LP 004** tavolino / side table

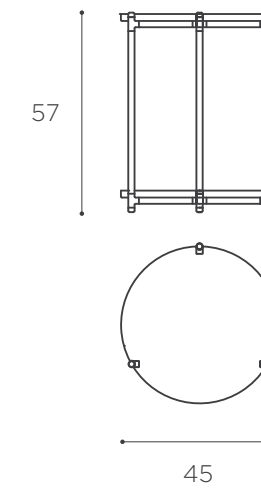

**ROCK NIGHTSTAND**

**RI 009** comodino / nightstand

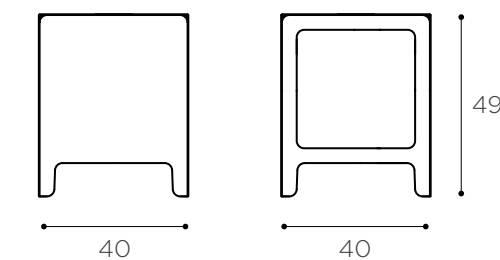

**TOID**

**TD 001** tavolino / side table

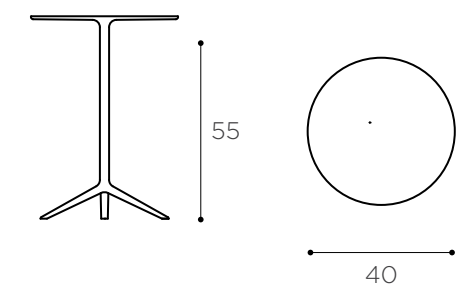

## GOTHAM BENCH

GT 007 panchetta / bench

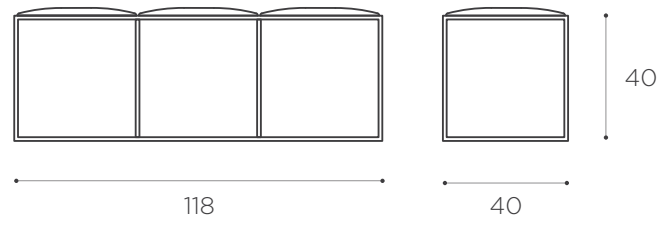

## NEW OUTLINE BENCH

OL 003 panchetta / bench

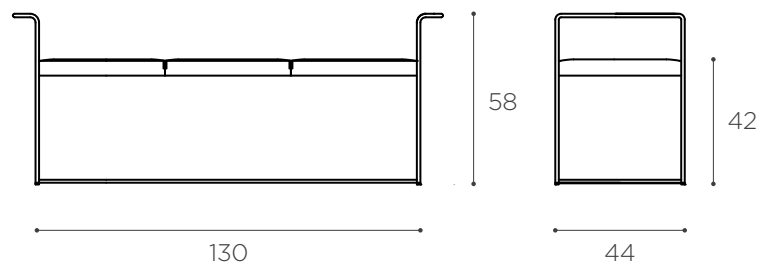

## LONG PLAYING ÉTAGÈRE

LP 002 étagère / étagère

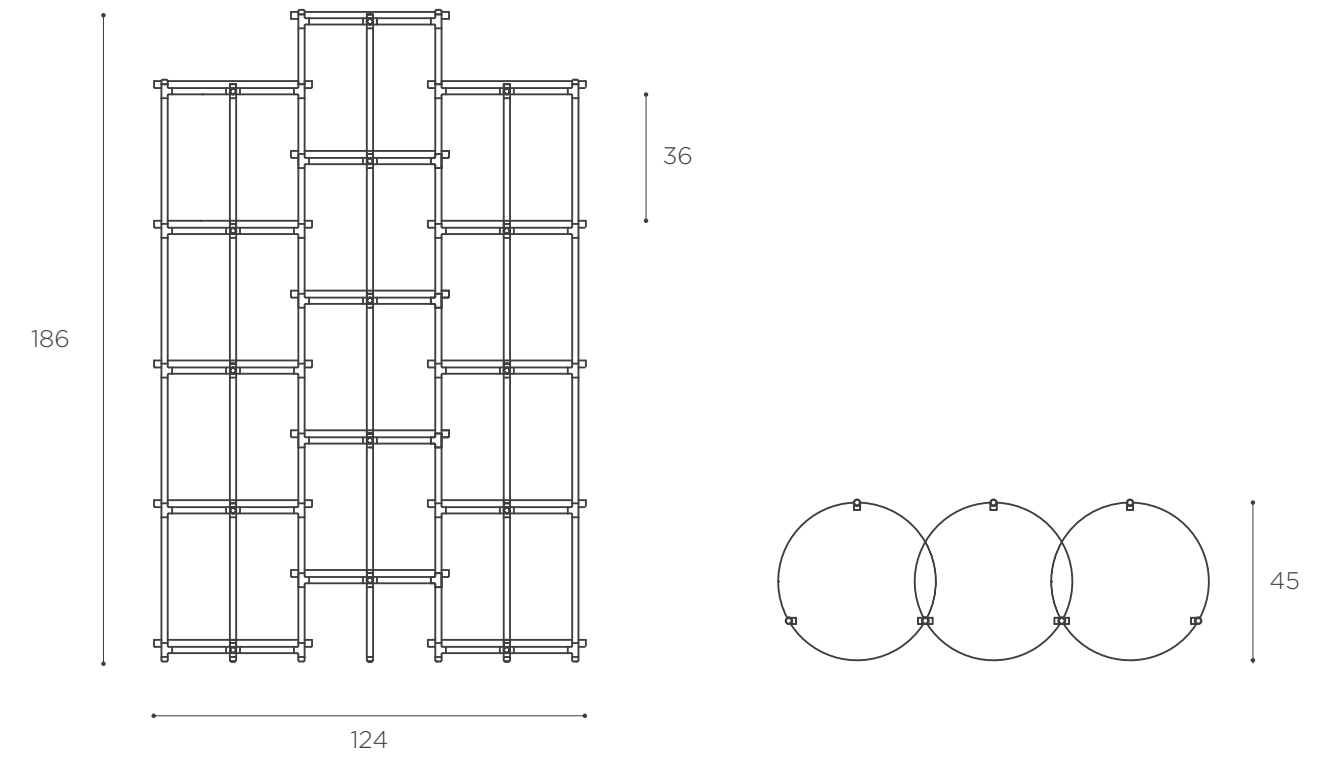

## GOTHAM WARDROBE

GT 004 / GT 009 appendiabiti / wardrobe

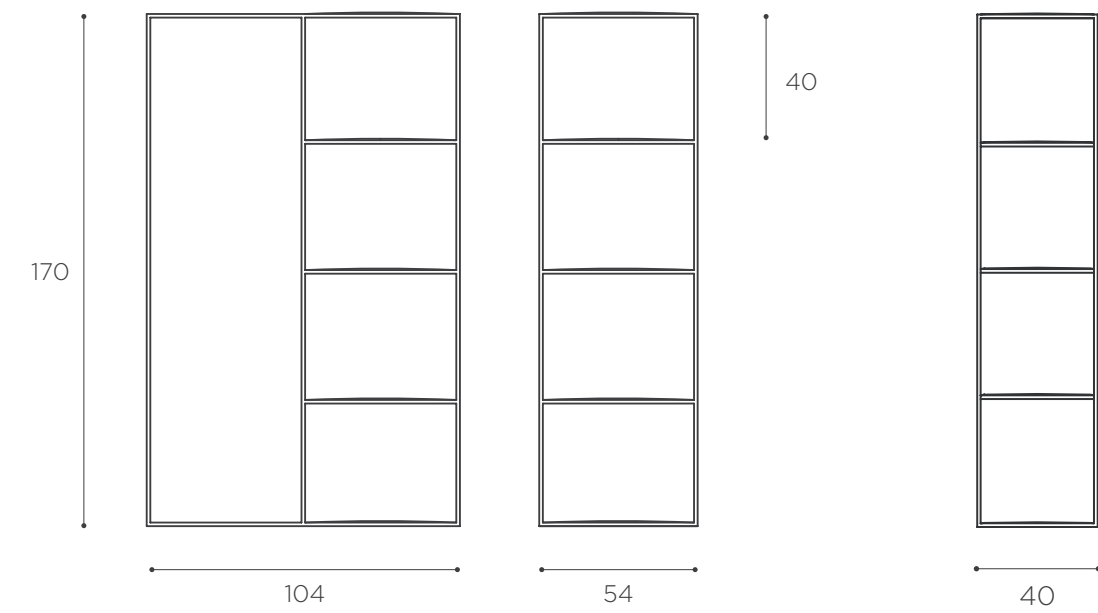

## ALUSTOOL

AL 002 sgabello / stool

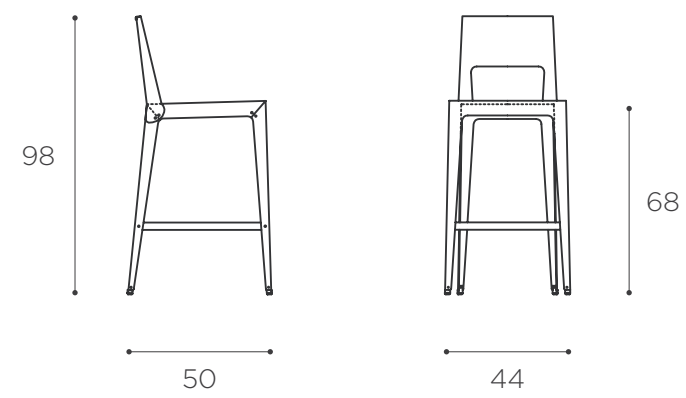

**Photo**

Ezio Manciuca

Eponimo reserves the right to introduce technological and aesthetic improvements to its products without prior notice. The measurements and finishes reported in this catalogue are to be considered indicative and subject to possible modifications.

© 2025 Eponimo - all rights reserved

# EPÒNIMO

[www.eponimo.it](http://www.eponimo.it)  
[info@eponimo.it](mailto:info@eponimo.it)