



OFFICINE GULLO
FIRENZE



GULLO PROFESSIONAL GRILLS

A RESTAURANT IN YOUR GARDEN



Blending a legacy of innovation and craftsmanship through the highest quality cooking systems, Officine Gullo Grill Cooking Suite embrace a new world of culinary possibilities, providing an actual outdoor kitchen in a single suite: a sophisticated cooking range that guarantees the same unparalleled performance as a top restaurant kitchen. It's a centerpiece around which family and friends can gather in the open air.

Thanks to an array of sophisticated accessories, the barbecues enable home cooks to experiment up to 15 different cooking methods, from the usual grilling to smoking, steaming and frying. The barbecues come with accessories that comprise specialist cooking zones.

Officine Gullo Professional Grills are equipped with powerful and highly specialized burners capable of reaching high temperatures and restaurant-level performance. Reaching 800° in just 4 minutes, the infrared burners cook meat 50% quicker than the usual barbecue, therefore avoiding flames that risk burning the food.

The barbecues are manufactured in the highest quality 316 stainless steel, devoid of any ferrous element, hence offering unrivaled duration and total corrosion resistance, plus elegant design. The stainless steel of the structure can be painted in any color in the RAL range as well as custom colors on request, in addition to finishing touches through iconic brass details.



OG PROFESSIONAL GRILL 100

BUILT-IN | BBQ42T



Grill Cooking Suite 100 is the perfect barbecue for outdoor cooking enthusiasts. Measuring 107 cm wide, the BBQ guarantees performance suitable for all open-air cooking aspirations. Available in freestanding and built-in versions, with a cooking area of 500 cm², the barbecue is equipped with three main high-performance stainless steel burners and an integrated smoking and rotisserie system. An accessories set allows the extension of the range of barbecue cooking methods. The OG Professional Grill has its own barbecue cover.

The OG Professional Grill comes with Natural Gas connection. LP conversion kit on request.

COUNTERTOP CUTOUT REQUIREMENTS

TECHNICAL DRAWINGS

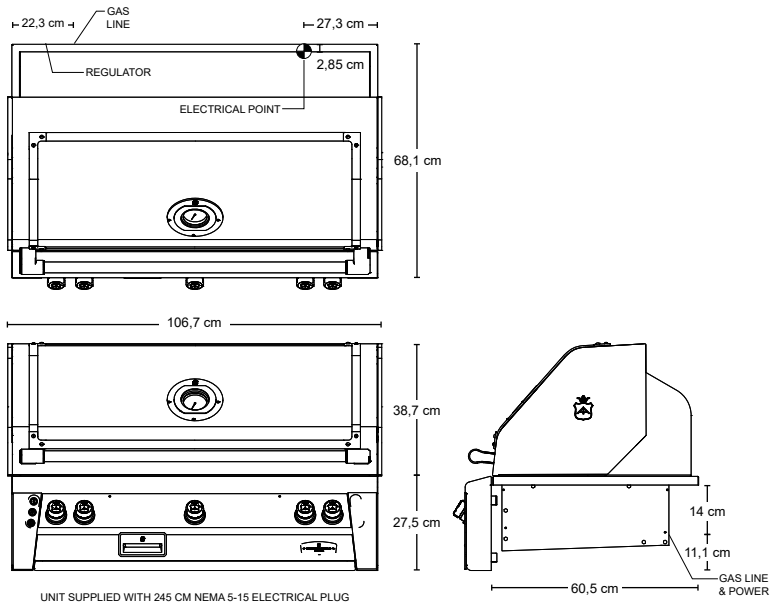
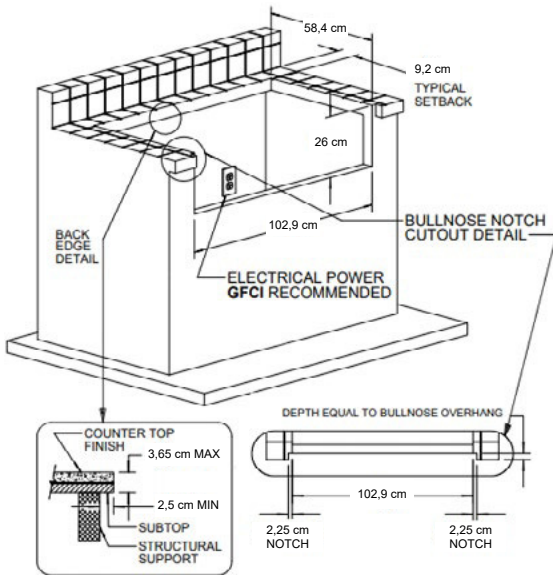

kW = 32
FUEL = NG @ 5" W.C. OR LP @ 10" W.C.
ELECTRICAL POWER = 230 VAC / 0,8 AMPS / 50 Hz.
GAS CONNECTION = 1/2" NPT (NG) OR 3/8" ODF (LP)

FEATURES

- Three 18-SR stainless steel high-performance main burners
- Integrated rotisserie system with infrared burner
- Integrated smoking system with dedicated burner and drawer for wood chunks
- 500 cm² actual grilling area
- 3-position warming rack stores up out of the way when rotissing
- Dual integrated high-intensity halogen work lights
- User-friendly push-button ignition with sealed 110V AC power source
- Available in LP or Natural Gas
- Barbecue cover

COOKING METHODS

- Searing
- Braising
- Frying
- Boiling
- Roasting
- Teppanyaki
- Grilling
- Baking
- Steaming
- Wok Cooking
- Blanching
- Smoking
- Griddle Cooking
- Cold Smoke Roasting
- Rotisserie Cooking

OPTIONAL GRILL ACCESSORIES



Steamer / Fryer / Pasta Cooker



Professional griddle

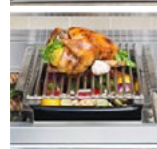

Roasting Module

Wind protection



OG PROFESSIONAL GRILL 100

FREESTANDING | **BBQ42**



Grill Cooking Suite 100 is the perfect barbecue for outdoor cooking enthusiasts. Measuring 107 cm wide, the BBQ guarantees performance suitable for all open-air cooking aspirations. Available in freestanding and built-in versions, with a cooking area of 500 cm², the barbecue is equipped with three main high-performance stainless steel burners and an integrated smoking and rotisserie system. An accessories set allows the extension of the range of barbecue cooking methods. The OG Professional Grill has its own barbecue cover.

The OG Professional Grill comes with Natural Gas connection. LP conversion kit on request.

TECHNICAL DRAWINGS

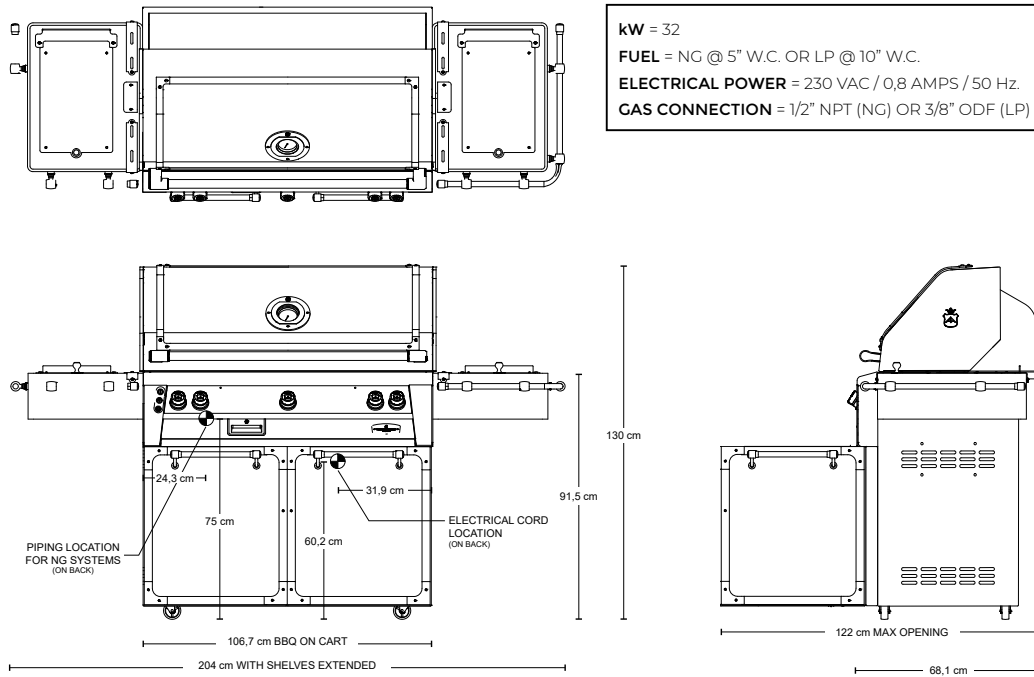

FEATURES

- Three 18-SR stainless steel high-performance main burners
- Integrated rotisserie system with infrared burner
- Integrated smoking system with dedicated burner and drawer for wood chunks
- 0,5 m² actual grilling area
- 3-position warming rack stores up out of the way when rotissing
- Dual integrated high-intensity halogen work lights
- User-friendly push-button ignition with sealed 110V AC power source
- Available in LP or Natural Gas
- Barbecue cover

COOKING METHODS

- Searing
- Braising
- Frying
- Boiling
- Roasting
- Teppanyaki
- Grilling
- Baking
- Steaming
- Wok Cooking
- Blanching
- Smoking
- Griddle Cooking
- Cold Smoke Roasting
- Rotisserie Cooking

OPTIONAL GRILL ACCESSORIES



Steamer / Fryer / Pasta Cooker



Professional griddle



Roasting Module

Wind protection



OG PROFESSIONAL GRILL 140

BUILT-IN | BBQ56T



Grill Cooking Suite 140, with its 650 cm² grill area, ensures high performance for home cooks looking for a professional, high-technology cooking range for their outdoor kitchen. Available in freestanding and built-in versions, the barbecue is equipped with three main high-performance stainless steel burners and an integrated smoking and rotisserie system. An accessories set allows the extension of the range of barbecue cooking methods. The OG Professional Grill has its own barbecue cover.

The OG Professional Grill comes with Natural Gas connection. LP conversion kit on request.

COUNTERTOP CUTOUT REQUIREMENTS

TECHNICAL DRAWINGS

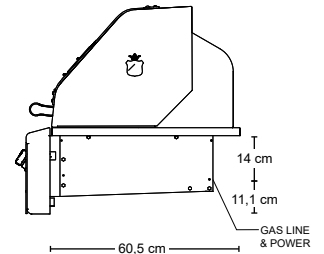
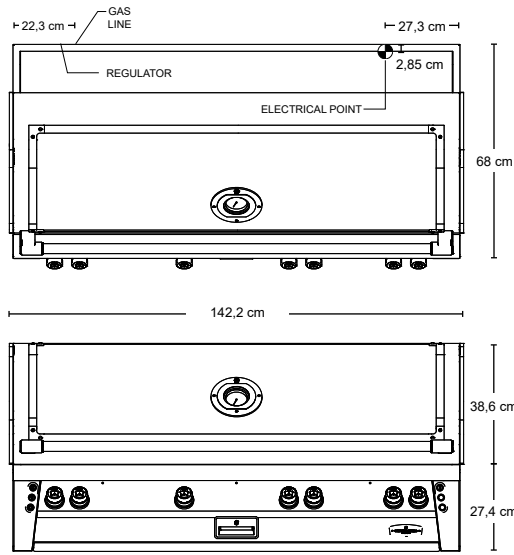
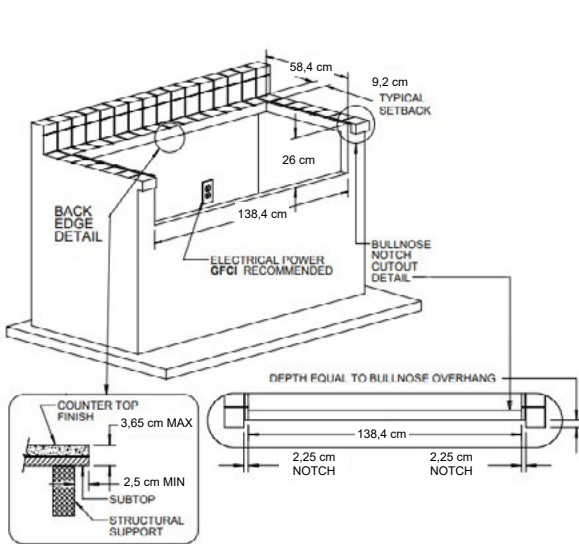

kw = 45
FUEL = NG @ 5" W.C. OR LP @ 10" W.C.
ELECTRICAL POWER = 230 VAC / 0,8 AMPS / 50 Hz.
GAS CONNECTION = 1/2" NPT (NG) OR 3/8" ODF (LP)

FEATURES

- Three 18-SR stainless steel high-performance main burners
- Integrated rotisserie system with infrared burner
- Integrated smoking system with dedicated burner and drawer for wood chunks
- 0,63 m² actual grilling area
- 3-position warming rack stores up out of the way when rotissing
- Dual integrated high-intensity halogen work lights
- User-friendly push-button ignition with sealed 110V AC power source
- Available in LP or Natural Gas
- Barbecue cover

COOKING METHODS

- Searing
- Braising
- Frying
- Boiling
- Roasting
- Teppanyaki
- Grilling
- Baking
- Steaming
- Wok Cooking
- Blanching
- Smoking
- Griddle Cooking
- Cold Smoke Roasting
- Rotisserie Cooking

OPTIONAL GRILL ACCESSORIES



Steamer / Fryer / Pasta Cooker



Professional griddle

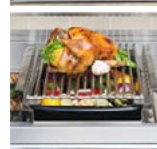

Roasting Module

Wind protection



OG PROFESSIONAL GRILL 140

FREESTANDING | **BBQ56**



Grill Cooking Suite 140, with its 650 cm² grill area, ensures high performance for home cooks looking for a professional, high-technology cooking range for their outdoor kitchen. Available in freestanding and built-in versions, the barbecue is equipped with three main high-performance stainless steel burners and an integrated smoking and rotisserie system. An accessories set allows the extension of the range of barbecue cooking methods. The OG Professional Grill has its own barbecue cover.

The OG Professional Grill comes with Natural Gas connection. LP conversion kit on request.

TECHNICAL DRAWINGS

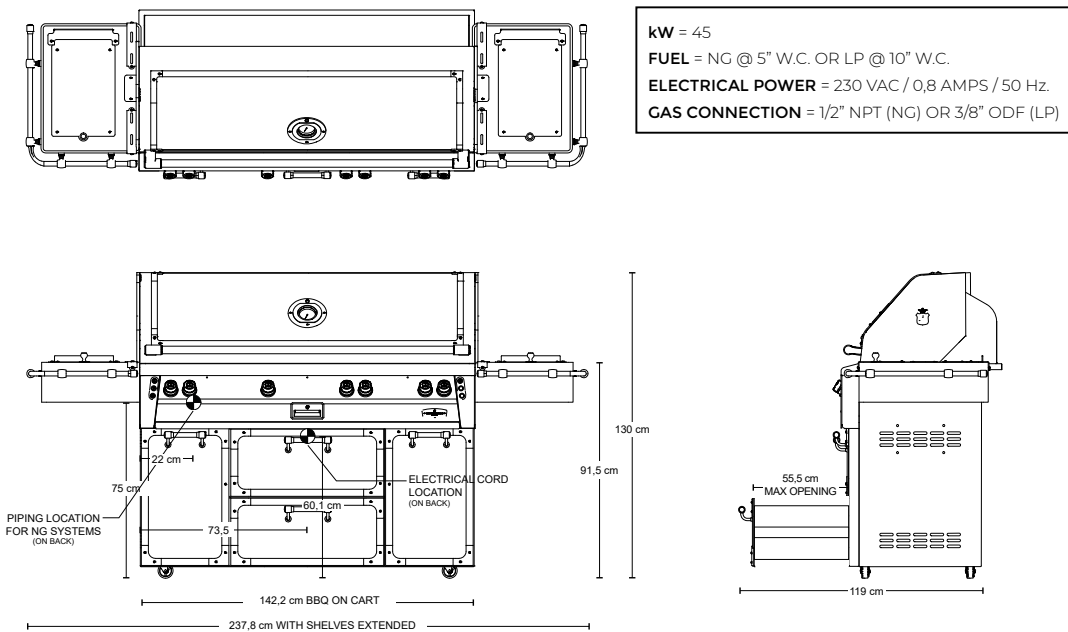

FEATURES

- Three 18-SR stainless steel high-performance main burners
- Integrated rotisserie system with infrared burner
- Integrated smoking system with dedicated burner and drawer for wood chunks
- 0,63 m² actual grilling area
- 3-position warming rack stores up out of the way when rotissing
- Dual integrated high-intensity halogen work lights
- User-friendly push-button ignition with sealed 110V AC power source
- Available in LP or Natural Gas
- Barbecue cover

COOKING METHODS

- Searing
- Braising
- Frying
- Boiling
- Roasting
- Teppanyaki
- Grilling
- Baking
- Steaming
- Wok Cooking
- Blanching
- Smoking
- Griddle Cooking
- Cold Smoke Roasting
- Rotisserie Cooking

OPTIONAL GRILL ACCESSORIES



Steamer / Fryer / Pasta Cooker



Professional griddle



Roasting Module

Wind protection



OG PROFESSIONAL GRILL 140 PLUS

BUILT-IN | BBQ56PT



With an integrated side burner, Grill Cooking Suite Plus is a cooking space measuring 500 cm² that guarantees high performance and versatility for an outdoor kitchen. Available in freestanding and built-in versions, the barbecue is equipped with three main high-performance stainless steel burners and an integrated smoking and rotisserie system. An accessories set allows the extension of the range of barbecue cooking methods. The OG Professional Grill has its own barbecue cover.

The OG Professional Grill comes with Natural Gas connection. LP conversion kit on request.

COUNTERTOP CUTOUT REQUIREMENTS

TECHNICAL DRAWINGS

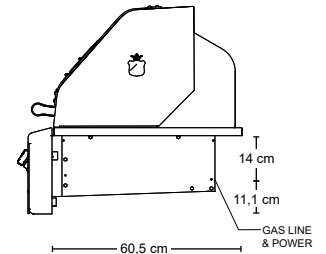
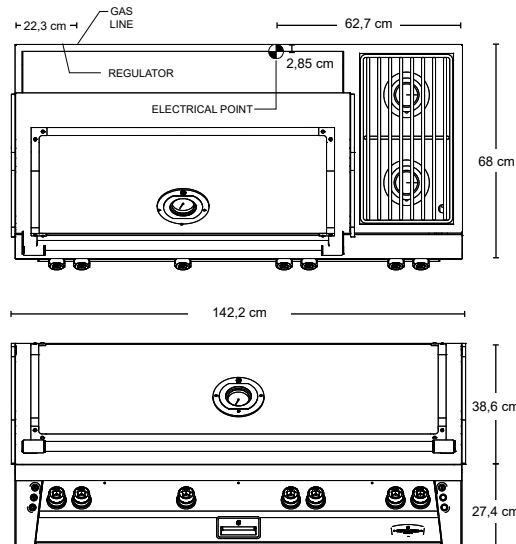
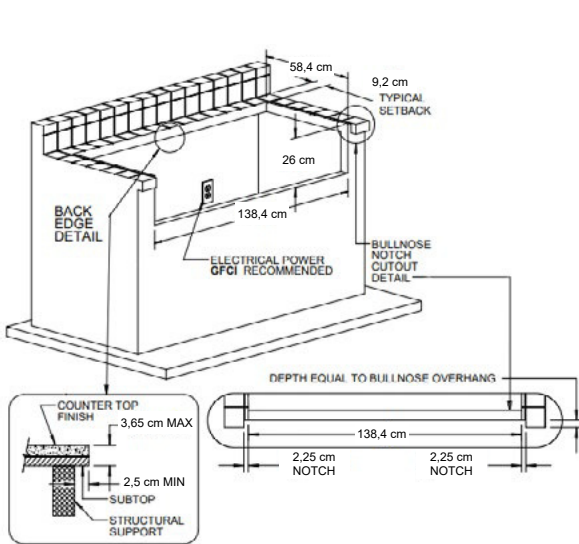

UNIT SUPPLIED WITH 245 CM NEMA 5-15 ELECTRICAL PLUG

kWh = 45
FUEL = NG @ 5" W.C. OR LP @ 10" W.C.
ELECTRICAL POWER = 230 VAC / 0,8 AMPS / 50 Hz.
GAS CONNECTION = 1/2" NPT (NG) OR 3/8" ODF (LP)

FEATURES

- Three 18-SR stainless steel high-performance main burners
- Integrated rotisserie system with infrared burner
- Integrated smoking system with dedicated burner and drawer for wood chunks
- Dual-integrated high performance side burner with recessed sealed top and stainless steel cover
- 0,5 m² actual grilling area
- 3-position warming rack stores up out of the way when rotissing
- Dual integrated high-intensity halogen work lights
- User-friendly push-button ignition with sealed 110V AC power source
- Available in LP or Natural Gas
- Barbecue cover

COOKING METHODS

- Searing
- Braising
- Frying
- Boiling
- Roasting
- Teppanyaki
- Grilling
- Baking
- Steaming
- Wok Cooking
- Blanching
- Smoking
- Griddle Cooking
- Cold Smoke Roasting
- Rotisserie Cooking

OPTIONAL GRILL ACCESSORIES



Steamer / Fryer / Pasta Cooker



Professional griddle



Roasting Module

Wind protection



OG PROFESSIONAL GRILL 140 PLUS

FREESTANDING | **BBQ56P**



With an integrated side burner, Grill Cooking Suite Plus is a cooking space measuring 500 cm² that guarantees high performance and versatility for an outdoor kitchen. Available in freestanding and built-in versions, the barbecue is equipped with three main high-performance stainless steel burners and an integrated smoking and rotisserie system. An accessories set allows the extension of the range of barbecue cooking methods. The OG Professional Grill has its own barbecue cover.

The OG Professional Grill comes with Natural Gas connection. LP conversion kit on request.

TECHNICAL DRAWINGS

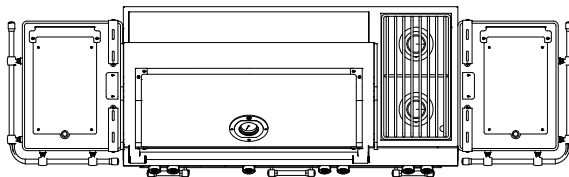

kW = 45
FUEL = NG @ 5" W.C. OR LP @ 10" W.C.
ELECTRICAL POWER = 230 VAC / 0,8 AMPS / 50 Hz.
GAS CONNECTION = 1/2" NPT (NG) OR 3/8" ODF (LP)

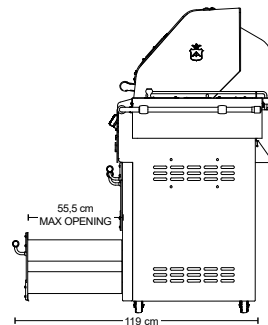
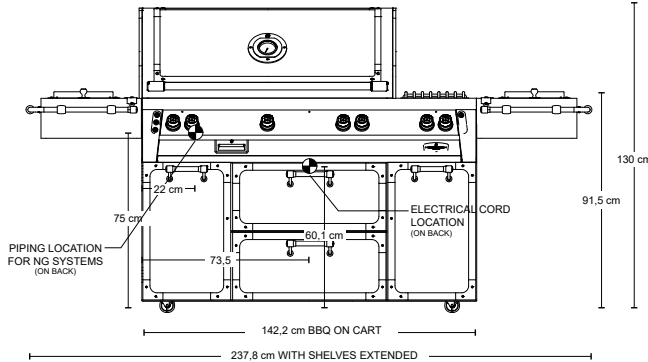

FEATURES

- Three 18-SR stainless steel high-performance main burners
- Integrated rotisserie system with infrared burner
- Integrated smoking system with dedicated burner and drawer for wood chunks
- Dual-integrated high performance side burner with recessed sealed top and stainless steel cover
- 0,5 m² actual grilling area
- 3-position warming rack stores up out of the way when rotissing
- Dual integrated high-intensity halogen work lights
- User-friendly push-button ignition with sealed 110V AC power source
- Available in LP or Natural Gas
- Barbecue cover

COOKING METHODS

- Searing
- Braising
- Frying
- Boiling
- Roasting
- Teppanyaki
- Grilling
- Baking
- Steaming
- Wok Cooking
- Blanching
- Smoking
- Griddle Cooking
- Cold Smoke Roasting
- Rotisserie Cooking

OPTIONAL GRILL ACCESSORIES



Steamer / Fryer / Pasta Cooker



Professional griddle



Roasting Module

Wind protection



OG PROFESSIONAL GRILL 100

FREESTANDING | **BBQ42**



BUILT-IN | **BBQ42T**



BBQ42	107 CM FREESTANDING BARBECUE NATURAL GAS CONNECTION, LP CONVERSION KIT ON REQUEST	€ 10.100,00
BBQ42T	107 CM BUILT-IN BARBECUE NATURAL GAS CONNECTION, LP CONVERSION KIT ON REQUEST	€ 7.930,00

OG PROFESSIONAL GRILL 140

FREESTANDING | **BBQ56**



BUILT-IN | **BBQ56T**



BBQ56	142 CM FREESTANDING BARBECUE NATURAL GAS CONNECTION, LP CONVERSION KIT ON REQUEST	€ 13.530,00
BBQ56T	142 CM BUILT-IN BARBECUE NATURAL GAS CONNECTION, LP CONVERSION KIT ON REQUEST	€ 11.220,00

OG PROFESSIONAL GRILL 140 PLUS

FREESTANDING | **BBQ56P**









BUILT-IN | **BBQ56PT**



BBQ56P	142 CM PLUS FREESTANDING BARBECUE NATURAL GAS CONNECTION, LP CONVERSION KIT ON REQUEST	€ 13.545,00
BBQ56PT	142 CM PLUS BUILT-IN BARBECUE NATURAL GAS CONNECTION, LP CONVERSION KIT ON REQUEST	€ 9.765,00

OG PROFESSIONAL GRILL ACCESSORIES

	BBQAPC	STEAMER/FRYER/PASTA COOKER	€ 730,00
	BBQAFT	PROFESSIONAL GRIDDLE	€ 450,00
	BBQARP	ROASTING MODULE	€ 450,00
	BBQAWG42T	WIND PROTECTION (FOR GRILL 100 BUILT-IN)	€ 550,00
	BBQAWG42	WIND GUARD (FOR GRILL 100 FREESTANDING)	€ 550,00
	BBQAWG56T	WIND GUARD (FOR GRILL 140 AND 140 PLUS BUILT-IN)	€ 635,00
	BBQAWG56	WIND GUARD (FOR GRILL 140 AND 140 PLUS FREESTANDING)	€ 635,00