



26

OLEV

EXCLUSIVE LAMPS
Made in Italy

EXCLUSIVE LAMPS

Made in Italy



Andrea Lanaro, CEO and Founder of OLEV
Andrea

Creare emozioni con la luce
è una delle cose
che più mi emoziona.

Creating emotions with light
it's one of the things
which thrills me the most.

OLEV

Italian Story

1970's



Nasce l'azienda a conduzione familiare. Si producono lampadari in ferro battuto a mano.

Foundation of the company. Handcrafted wrought iron chandeliers were produced.

2000



Arrivano i primi LED sul mercato e OLEV cambia direzione: inizia a produrre lampade di design dalle forme originali.

With LED revolution, OLEV became an industrial company based on production of designer lamps.

2014

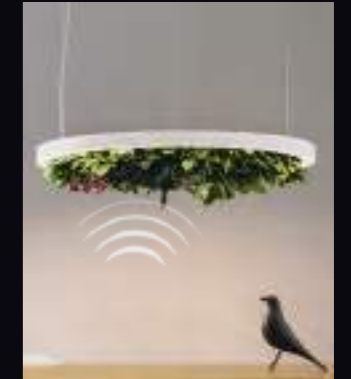

OLEV crea lampade innovative in grado di imitare la luce del Sole, di assorbire i rumori, di purificare l'aria.

OLEV started producing innovative lamps designed to replicate sunlight, absorb sound, and purify the air.

2020



La lampada Ottomano di OLEV vince la menzione d'onore agli European Product Design Award.

OLEV's Ottomano lamp won the honorable mention at the European Product Design Awards.

2023



OLEV vince il prestigioso titolo italiano Altagama Design Awards.

OLEV won the Italian Altagama Design Award.

2025



OLEV illumina progetti prestigiosi tra cui il ristorante 3 stelle Michelin 'Atelier Moessmer' di Norbert Niederkofler.

OLEV illuminated prestigious projects including the Michelin-starred restaurant 'Atelier Moessmer' by Norbert Niederkofler.

2025



La lampada a sospensione Baryon vince il Good Design Award.

The Baryon pendant lamp won the Good Design Award.



OLEV

Italian 
*Made
in Italy*

ORIGINALITA' ITALIANA

Nascono come pezzi unici, le nostre lampade sono create con cura artigianale e assemblate a mano nel nostro stabilimento italiano di Colceresa.

ONE-OF-A-KIND LIGHT

Elegant and refined, our lamps are curated as unique pieces, assembled in our Italian factory in Colceresa.



OLEV

*Light for
visual comfort*



COMFORT VISIVO

I filtri a nido d'ape delle lampade OLEV eliminano qualsiasi bagliore o riflesso indesiderato, garantendo un comfort visivo ottimale per i nostri occhi.

VISUAL COMFORT

The honeycomb filters in OLEV lamps eliminate any unwanted glare or reflection, ensuring optimal visual comfort for our eyes.



BEAM MASTER TRACK 48V 60

OLEV
Senza filtro a nido d'ape Con filtro a nido d'ape
Without honeycomb filter With honeycomb filter

OLEV

*Light for
acoustic
wellbeing*



COMFORT ACUSTICO

Le lampade fonoassorbenti della collezione Silence di OLEV aiutano a ridurre la rumorosità degli ambienti, aumentando il benessere del corpo umano.

ACOUSTIC COMFORT

OLEV's Silence collection features acoustic lighting designed to lower noise levels and improve overall physical well-being.



GAVIN SILENCE LEAF

OLEV

*Light for
natural rhythm*

BENESSERE PSICOFISICO

La luce Biolight di OLEV riproduce le variazioni in tonalità e temperatura della luce del Sole durante l'arco della giornata, ricreando un'illuminazione naturale che rispetta il nostro ritmo circadiano biologico del corpo umano.

HOLISTIC WELL-BEING

OLEV Biolight mimics the Sun's natural cycle by shifting from warm to cool tones, ensuring natural illumination that aligns perfectly with our circadian rhythms.

EXAGON SILENCE BIOLIGHT

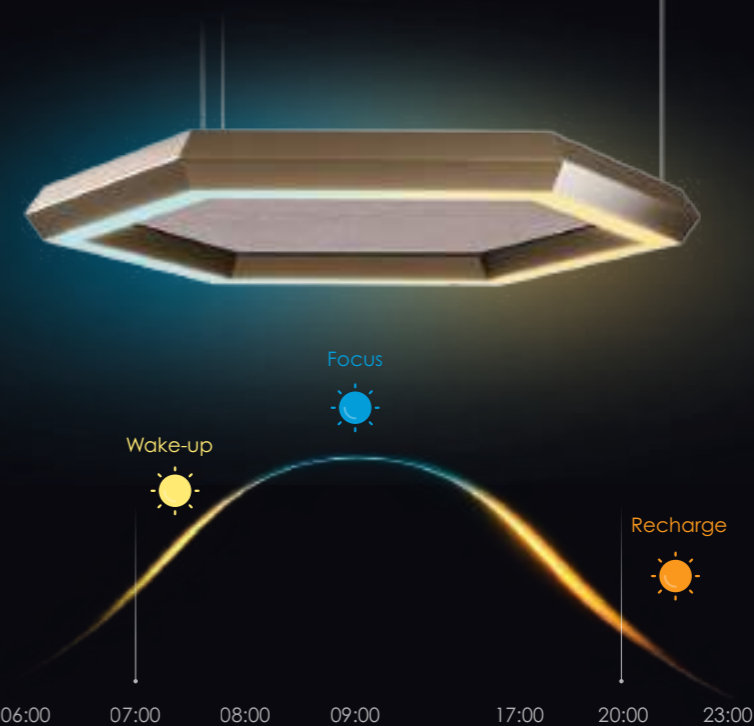

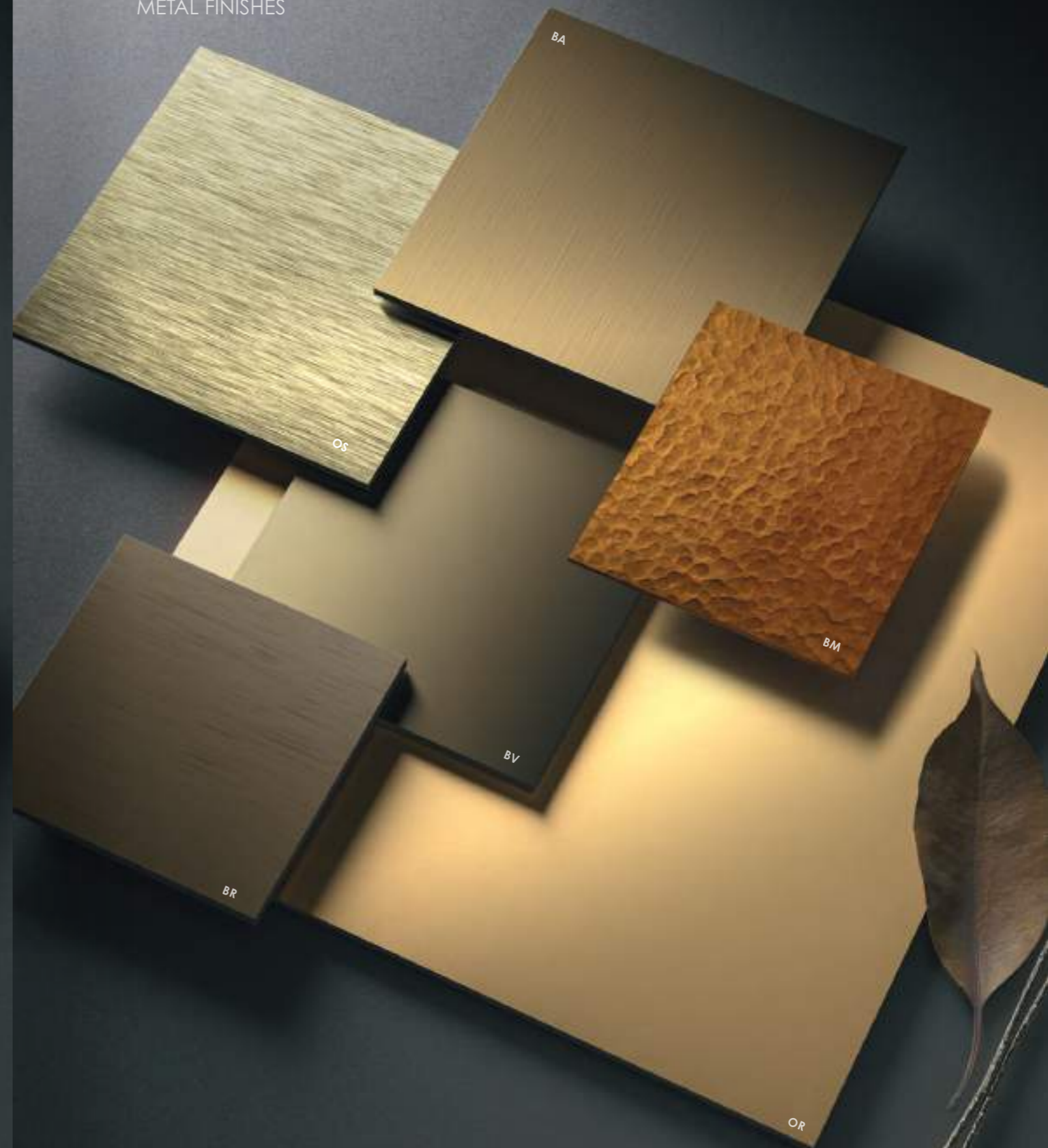

FINITURE METALLICHE
METAL FINISHES



FINITURE METALLICHE
METAL FINISHES



COLORI VETRO
GLASS COLOURS



COLORI VETRO BALLOTON
BALLOTON GLASS COLOURS



INDOOR

LAMPADE A SOSPENSIONE
SUSPENSION LAMPS

Indice interattivo:
clicca sulla foto
Interactive index:
click on the photo





NEW  **NEW**  **NEW**  

ASTRELLE
PAGE 28

ASTRELLE GLOBAL
PAGE 34

ASTRELLE ELLIX
PAGE 34

BARYON
PAGE 48

BEAM STICK GLASS
PAGE 124

BEAM STICK METAL
PAGE 128

BEAM STICK NUANCE
PAGE 68

**BEAM STICK NUANCE
BALLOTON Ø350**
PAGE 78

**BEAM STICK NUANCE
Ø450**
PAGE 84

CURUBA
PAGE 54

CURUBA COMBO
PAGE 64

EXAGON
PAGE 104





**EXAGON
SILENCE**
PAGE 108

**EXAGON
SILENCE
GREEN**
PAGE 109

**EXAGON SILENCE
BIOLIGHT**
PAGE 110

GAVIN
PAGE 98

GAVIN SILENCE LEAF
PAGE 100

LA PALLINA SP
PAGE 164

LANACOTTA
PAGE 160

LIKESHADE
PAGE 138

LIKESHADOW
PAGE 42

LONGUETTE
PAGE 146

MEETING SILENCE LEAF
PAGE 156

MERCEDES
PAGE 152



OVERFLY
PAGE 88

OVERFLY PLUS
PAGE 94

POLY ESAGONO
PAGE 112

POLY LINEAR
PAGE 116

SHINE VERTICAL
PAGE 144













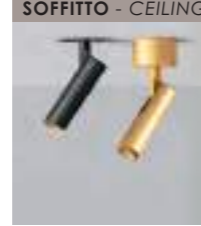
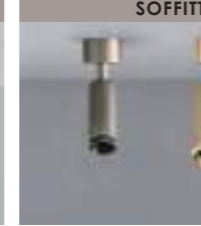



**SHINE VERTICAL
PLUMAGE**
PAGE 142



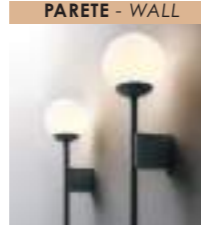
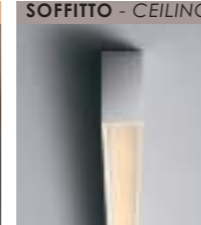
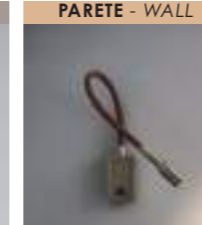







TRISEL
PAGE 120

INDOOR

LAMPADE DA SOFFITTO & PARETE
CEILING & WALL LAMPS

Indice interattivo:
clicca sulla foto
Interactive index:
click on the photo

NEW PARETE - WALL  ASTRELLE GLOBAL AP PAGE 174	NEW PARETE - WALL  ASTRELLE ELLIX AP PAGE 170	PARETE - WALL SOFFITTO - CEILING  BEAM MASTER Ø25 PAGE 226	PARETE - WALL SOFFITTO - CEILING  BEAM MASTER Ø35 - 60 - 80 PAGE 226,228	SOFFITTO - CEILING  BEAM MASTER Ø60 ZUMMY PAGE 230	PARETE - WALL  CHARMER AP PAGE 198	SOFFITTO - CEILING  CURUBA PL PAGE 178	PARETE - WALL SOFFITTO - CEILING  EYE SPOT PAGE 234	PARETE - WALL SOFFITTO - CEILING  EYE SPOT 230V PAGE 234	SOFFITTO - CEILING  FLUENTIS PAGE 212	PARETE - WALL  KINETIKA PAGE 216	PARETE - WALL  LA PALLINA AP PAGE 256	SOFFITTO - CEILING  MERCEDES PL PAGE 254	PARETE - WALL  OLORFLEX PAGE 240	PARETE - WALL SOFFITTO - CEILING  ORNATO PAGE 182	PARETE - WALL  OTTOMANO PAGE 188	SOFFITTO - CEILING  OVERFLY PLUS PL PAGE 206	SOFFITTO - CEILING  PIPE PL PAGE 258	PARETE - WALL SOFFITTO - CEILING  POLY ESAGONO PL PAGE 202
--	---	---	--	---	---	---	--	--	---	--	---	---	--	--	--	--	---	---

PARETE - WALL  SHINE PLUMAGE AP PAGE 244	PARETE - WALL SOFFITTO - CEILING  SHINE SPOT PAGE 238	PARETE - WALL SOFFITTO - CEILING  SHINE SPOT 230V PAGE 236	PARETE - WALL  SLIGHT AP PAGE 246	PARETE - WALL  TAB LED PAGE 252	NEW PARETE - WALL  TIMELINE PAGE 248	PARETE - WALL  TRISEL AP PAGE 194	NEW PARETE - WALL  TUBELIA PAGE 220	PARETE - WALL  TURN PAGE 260	PARETE - WALL  ZEN PAGE 250
--	--	---	---	---	---	--	--	---	--

INDOOR

LAMPADE DA SOFFITTO INCASSO
RECESSED CEILING LAMPS

SOFFITTO - CEILING  TINY PAGE 264	SOFFITTO - CEILING  TINY GHOST PAGE 264	SOFFITTO - CEILING  TINY ADJUSTABLE PAGE 266	SOFFITTO - CEILING  TINY ADJUSTABLE GHOST PAGE 266
---	---	--	--

INDOOR

LAMPADRE DA BINARIO 48V
TRACK LAMPS 48V

Indice interattivo:
clicca sulla foto
Interactive index:
click on the photo

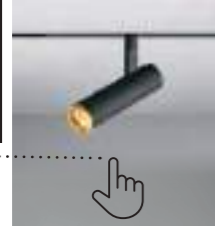

BEAM MASTER
MICRO TRACK 48V Ø25
PAGE 318



BEAM MASTER TRACK 48V Ø35 - 60 - 80
PAGE 318



BEAM MASTER
TRACK 48V
Ø60 ZUMMY
PAGE 320



EYE SPOT
MICRO TRACK 48V
PAGE 323



EYE SPOT TRACK 48V
PAGE 322



OVERFLY TRACK 48V
PAGE 324



SHINE SPOT TRACK 48V
PAGE 326

LAMPADRE DA BINARIO 230V
TRACK LAMPS 230V



BEAM MASTER TRACK 230V Ø 60 - 80
PAGE 328

INDOOR

LAMPADRE DA TAVOLO
TABLE LAMPS



ANTARTIC
PAGE 270



LA PALLINA
PAGE 274

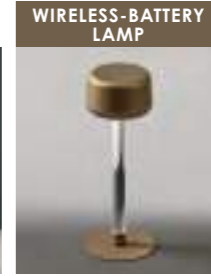

WIRELESS-BATTERY
LAMP
TEE
PAGE 278

LAMPADRE DA TERRA
FLOOR LAMPS

NEW



ASTRELLE PT
PAGE 284



BOOM
PAGE 304



CRANE
PAGE 308

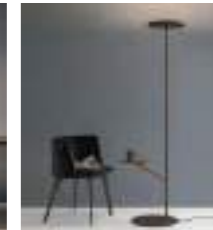

OVERFLY PT
PAGE 288



SLIGHT PT
PAGE 312



THIRTIES
PAGE 300

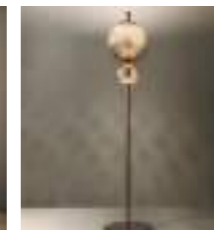

TERRA&LUNA PT
PAGE 296



TRISEL PT
PAGE 292



OUTDOOR

LAMPADRE DA PARETE WALL LAMPS

*Indice interattivo:
clicca sulla foto*
*Interactive index:
click on the photo*



MARKIL
PAGE 332

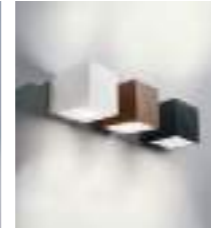

UP&DOWN
PAGE 336

LAMPADRE DA SOFFITTO INCASSO RECESSED CEILING LAMPS



MINI DOT DOWN LIGHT
PAGE 340



MAXI DOT DOWN LIGHT
PAGE 342



OUTDOOR

LAMPADRE DA TERRA FLOOR LAMPS



CEMENTO
PAGE 366



GROUNDING
PAGE 364



MAXI DOT SPOT
PAGE 372

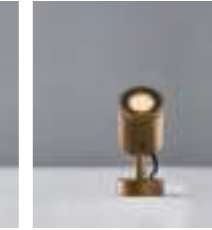

MINI DOT SPOT
PAGE 374



PEPITO
PAGE 346



SPREAD
PAGE 356



STEP LINE
PAGE 370



TORCH
PAGE 360



ZOELLA
PAGE 350

LAMPADRE DA TERRA INCASSO RECESSED FLOOR LAMPS



MAXI DOT UP LIGHT
PAGE 378



MINI DOT UP LIGHT
PAGE 380



MINI DOT GLASS UP LIGHT
PAGE 382

INDOOR

INDOOR

INDOOR

**LAMPADE A
SOSPENSIONE**

**SUSPENSION
LAMPS**

INDOOR

ASTRELLE

VETRO SOFFIATO A BOCCA
CON EFFETTO ALABASTRO

MOUTH-BLOWN GLASS WITH
ALABASTER FINISH



Design Marc Sadler
Registered Design



COMFORT VISIVO

Il fascio luminoso è addolcito dal filtro a nido d'ape che elimina qualsiasi riflesso o bagliore indesiderato. Questo rende la luce morbida e assicura un comfort ottimale per i nostri occhi.

VISUAL COMFORT

The light emission is diffused by the honeycomb filter, eliminating any glare or stray light. This results in a gentle illumination that guarantees maximum visual comfort.



Ruotando i bracci della lampada è possibile spostare la luce adattandola perfettamente allo spazio sottostante.

Adjustable arms allow for precise light positioning over the surrounding space.



ASTRELLE

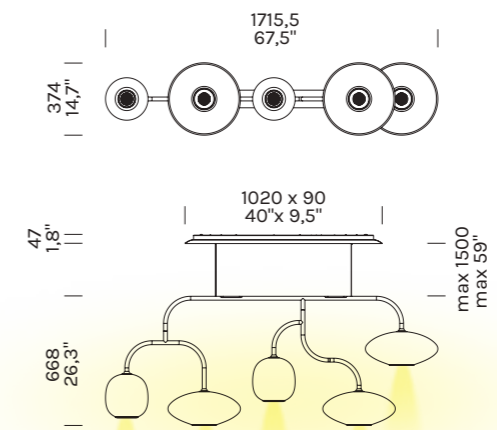

Ferro, alluminio, vetro soffiato a bocca
Iron, aluminum, mouth-blown glass



ANE FS

ASTRELLE *Global*

ASTRELLE *Ellix*

VETRO SOFFIATO A BOCCA
CON EFFETTO ALABASTRO

MOUTH-BLOWN GLASS WITH
ALABASTER FINISH



Design Marc Sadler
Registered Design

ASTRELLE *Global*



FIND OUT
ON OUR
WEBSITE



ASTRELLE *Ellix*



FIND OUT
ON OUR
WEBSITE





COMFORT VISIVO

Il fascio luminoso è addolcito dal filtro a nido d'ape che elimina qualsiasi riflesso o bagliore indesiderato. Questo rende la luce morbida e assicura un comfort ottimale per i nostri occhi.

VISUAL COMFORT

The light emission is diffused by the honeycomb filter, eliminating any glare or stray light. This results in a gentle illumination that guarantees maximum visual comfort.



COMFORT VISIVO

Il fascio luminoso è addolcito dal filtro a nido d'ape che elimina qualsiasi riflesso o bagliore indesiderato. Questo rende la luce morbida e assicura un comfort ottimale per i nostri occhi.

VISUAL COMFORT

The light emission is diffused by the honeycomb filter, eliminating any glare or stray light. This results in a gentle illumination that guarantees maximum visual comfort.



ASTRELLE *Global*

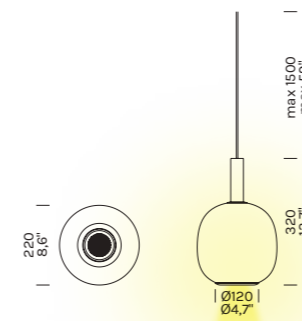

ASTRELLE *Ellix*

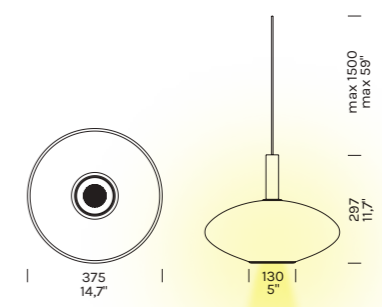

Rosoni a soffitto
Canopies

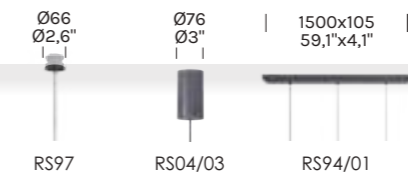

Ferro, alluminio, vetro soffiato a bocca
Iron, aluminum, mouth-blown glass

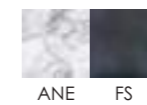

LIKESHADOW

FILO DI CARBONIO
INTRECCIATO A MANO

HAND-WOVEN
CARBON THREAD



Design Andrea Lanaro
Registered Design



RICAMO DI OMBRE IN MOVIMENTO CROSSOVER OF MOVING SHADOWS



Alzando il cappello in carbonio si ottiene un disegno di ombre **strette e intense**.

Raising the carbon cap a pattern of **intense shadows** is created.



Abbassando il cappello in carbonio si ottiene un disegno di ombre **ampie e morbide**.

Lowering the carbon cap a design characterized by **gentle shadows** is created.

FIND OUT
ON OUR
WEBSITE





LIKESHADOW

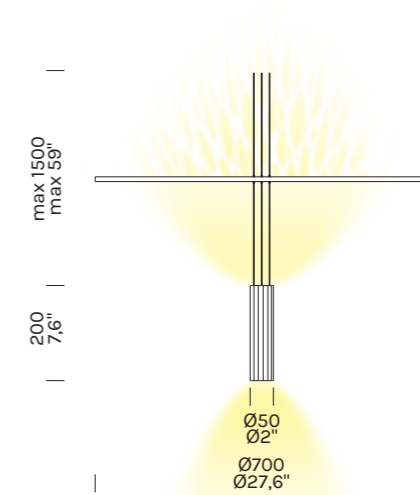

Rosoni a soffitto
Canopies

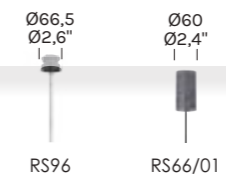

Alluminio, ottone, ferro,
filo di fibra di carbonio

Aluminum, brass, iron,
carbon fiber



BARYON

VETRO SOFFIATO A BOCCA
CON BOLLE D'ORO

MOUTH-BLOWN GLASS
WITH GOLDEN BUBBLES



As awarded by The Chicago Athenaeum:
Museum of Architecture and Design

FIND OUT
ON OUR
WEBSITE



Design De Amicis Architetti

Registered Design





DOPPIA FONTE LUMINOSA
Luce sia verso il basso, filtrata dalle bollicine del vetro, sia verso l'alto per illuminare l'ambiente nella sua interezza.

DOUBLE LIGHT SOURCE
Features both downward lighting, diffused by the glass bubbles, and upward lighting for full-room illumination.



Offices NTT DATA, Bari, Italy - Project: De Amicis Architetti - Ph: Alberto Strada

BARYON

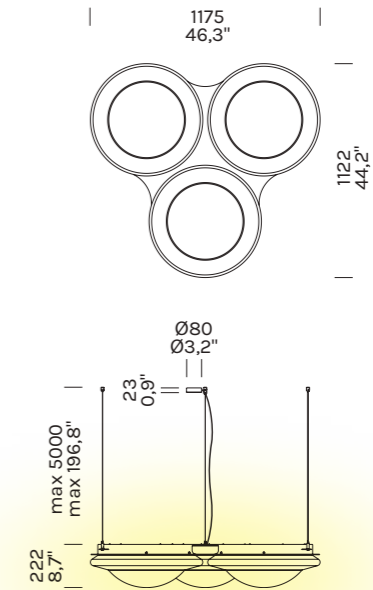
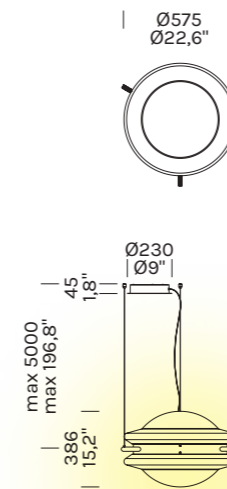

Ferro, alluminio,
vetro soffiato a bocca

Iron, aluminum,
mouth-blown glass



BP

CURUBA

VETRO SOFFIATO A BOCCA
E LAVORATO A MANO

MOUTH-BLOWN GLASS
WORKED BY HAND



Design Andrea Lanaro
Registered Design





COMFORT VISIVO

Il fascio luminoso è addolcito dal filtro a nido d'ape che elimina qualsiasi riflesso o bagliore indesiderato. Questo rende la luce morbida e assicura un comfort ottimale per i nostri occhi.

VISUAL COMFORT

The light emission is diffused by the honeycomb filter, eliminating any glare or stray light. This results in a gentle illumination that guarantees maximum visual comfort.









CURUBA

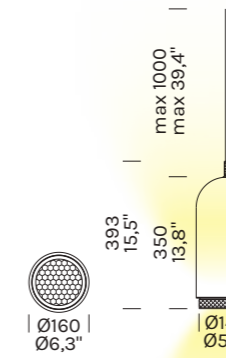

Rosoni a soffitto Canopies

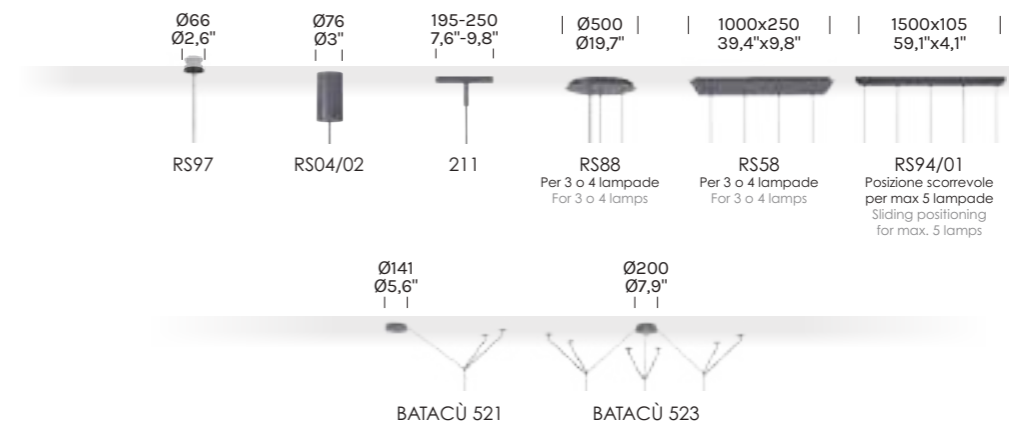

Alluminio e vetro soffiato a bocca Aluminum and mouth-blown glass



CURUBA COMBO

VETRO SOFFIATO A BOCCA
CON TEXTURE TRIDIMENSIONALE

MOUTH-BLOWN GLASS
WITH A THREE-DIMENSIONAL TEXTURE



Design Andrea Lanaro
Registered Design



CURUBA COMBO

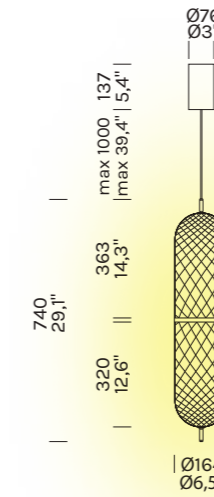

Alluminio e vetro soffiato a bocca
Aluminum and mouth-blown glass

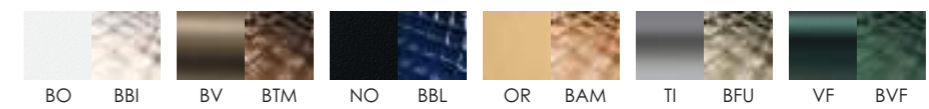

BEAM STICK NUANCE

VETRO SOFFIATO A BOCCA
E LAVORATO A MANO

MOUTH-BLOWN GLASS
WORKED BY HAND



FIND OUT
ON OUR
WEBSITE



Design Marc Sadler

Registered Design



Office REWE West - Cologne, Germany
Project designer: brandherm + krumrey interior architecture
Photo: Joachim Grotus Photography





FIND OUT
ON OUR
WEBSITE



DOPPIA SORGENTE LUMINOSA

Una illumina il vetro dal suo cuore interno,
l'altra proietta la luce verso il basso.

DOUBLE LIGHT SOURCE

One illuminates the glass from its inner heart,
the other projects the light downwards.



Vetro soffiato a bocca
con texture tridimensionale

Mouth-blown glass
with a three-dimensional texture



BATACÙ

Rosone multiplo che trasforma un singolo allaccio elettrico in un'installazione artistica. Ideale per gestire più lampade a sospensione anche disponendo di un solo punto luce.

Multi-light canopy: elevate a single connection into a work of art. The ideal solution for managing multiple pendants from one single light point.



BEAM STICK NUANCE

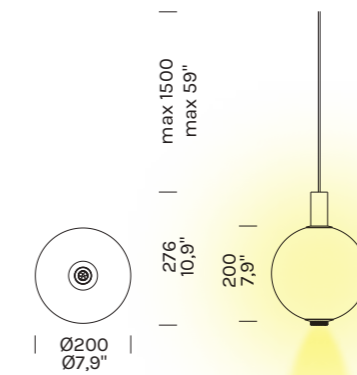

Rosoni a soffitto Canopies

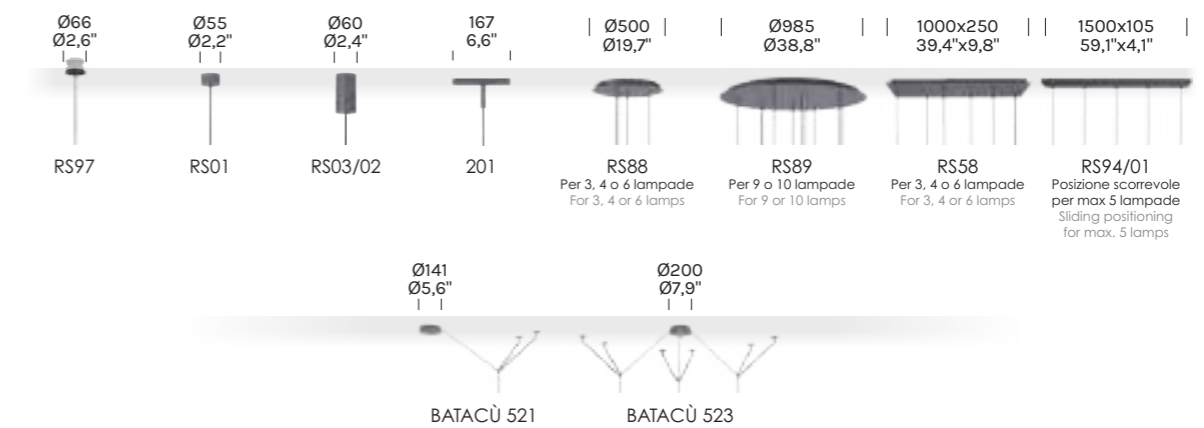

Alluminio e vetro soffiato a bocca Aluminum and mouth-blown glass

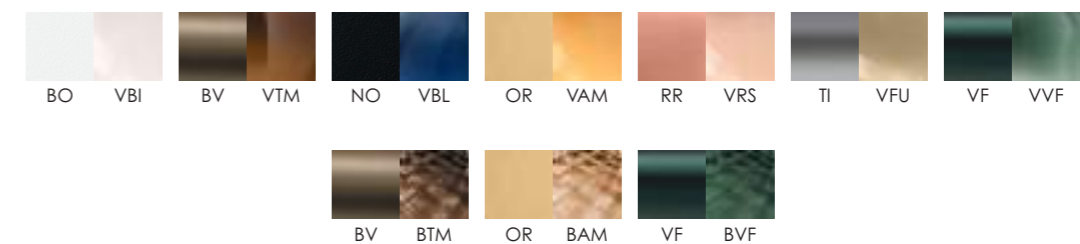

BEAM STICK NUANCE Ø350

Balloton

VETRO SOFFIATO A BOCCA
CON TEXTURE TRIDIMENSIONALE

MOUTH-BLOWN GLASS
WITH A THREE-DIMENSIONAL TEXTURE



DOPPIA SORGENTE LUMINOSA

Una illumina il vetro dal suo cuore interno,
l'altra proietta la luce verso il basso.

DOUBLE LIGHT SOURCE

One illuminates the glass from its inner heart,
the other projects the light downwards.

FIND OUT
ON OUR
WEBSITE



Design Marc Sadler

Registered Design





BEAM STICK NUANCE BALLOTON Ø350

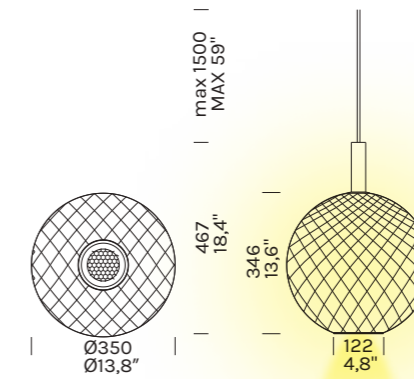

Rosoni a soffitto
Canopies

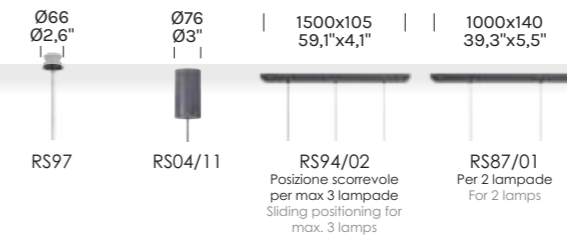

Alluminio e vetro soffiato a bocca
Aluminum and mouth-blown glass

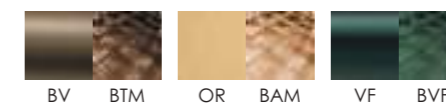

BEAM STICK NUANCE Ø450

VETRO SOFFIATO A BOCCA
E LAVORATO A MANO

MOUTH-BLOWN GLASS
WORKED BY HAND



Design Marc Sadler
Registered Design





DOPPIA SORGENTE LUMINOSA

Una illumina il vetro dal suo cuore interno,
l'altra proietta la luce verso il basso.

DOUBLE LIGHT SOURCE

One illuminates the glass from its inner heart,
the other projects the light downwards.

BEAM STICK NUANCE Ø450

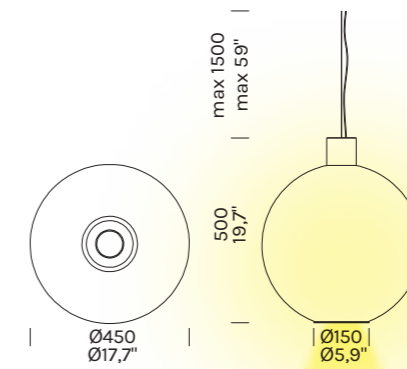

Rosoni a soffitto
Canopies

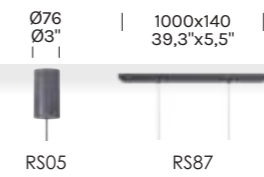

Alluminio e vetro soffiato a bocca
Aluminum and mouth-blown glass

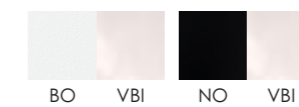

OVERFLY

VERNICIATO A MANO

PAINTED BY HAND



FIND OUT
ON OUR
WEBSITE



Design Marc Sadler

Registered Design



Le incisioni geometriche incrociate
impresziosiscono i dettagli

The crossed geometric engravings
enhance the details



COMFORT VISIVO

Il fascio luminoso è addolcito dal filtro a nido d'ape che elimina qualsiasi riflesso o bagliore indesiderato. Questo rende la luce morbida e assicura un comfort ottimale per i nostri occhi.

VISUAL COMFORT

The light emission is diffused by the honeycomb filter, eliminating any glare or stray light. This results in a gentle illumination that guarantees maximum visual comfort.





OVERFLY

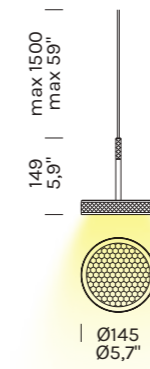

Rosoni a soffitto
Canopies

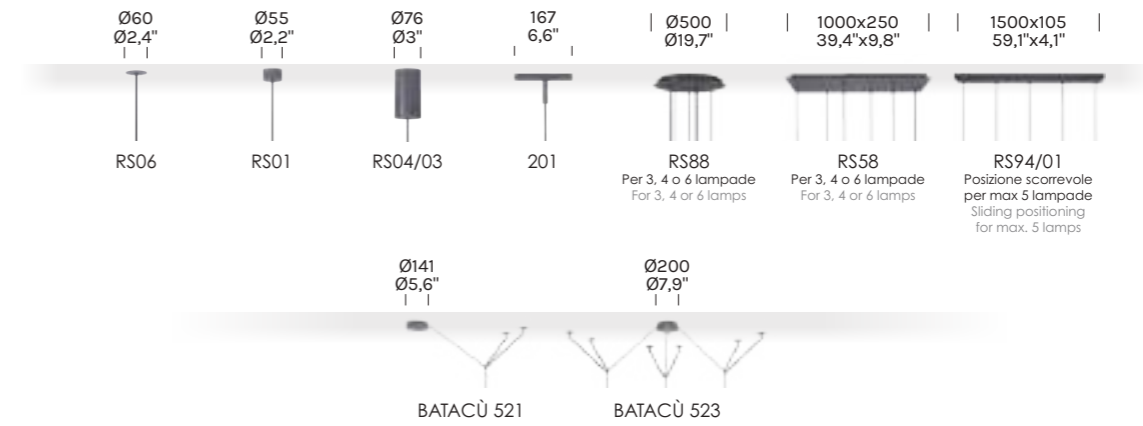

Alluminio, plexiglass
Aluminium, plexiglass



OVERFLY PLUS

VERNICIATO A MANO

PAINTED BY HAND



Design Marc Sadler
Registered Design



COMFORT VISIVO

Il fascio luminoso è addolcito dal filtro a nido d'ape che elimina qualsiasi riflesso o bagliore indesiderato. Questo rende la luce morbida e assicura un comfort ottimale per i nostri occhi.

VISUAL COMFORT

The light emission is diffused by the honeycomb filter, eliminating any glare or stray light. This results in a gentle illumination that guarantees maximum visual comfort.

OVERFLY PLUS

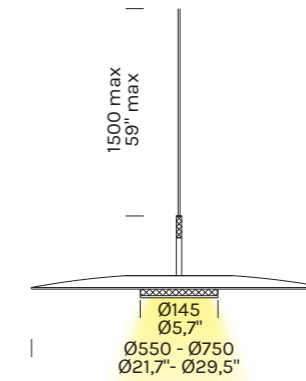

Rosoni a soffitto Canopies

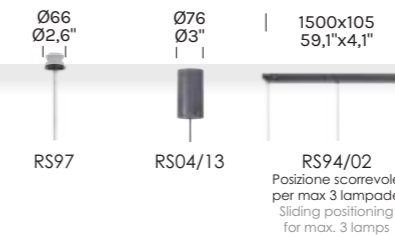

Alluminio, plexiglass
Aluminium, plexiglass



GAVIN



Design Massimo Tonetto
Registered Design



GAVIN

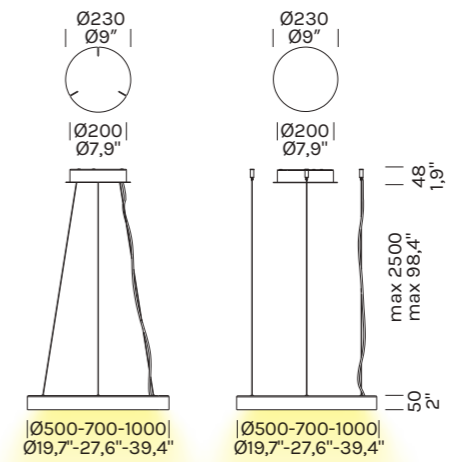

Ferro
Iron

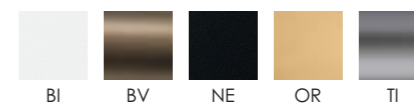

GAVIN SILENCE LEAF

FONOASSORBENTE
CON VERE FOGLIE STABILIZZATE

SOUND ABSORBING LAMP
WITH REAL STABILIZED LEAVES



Design OLEV Design Lab
Registered Design



GAVIN SILENCE LEAF



Vere foglie di eucalipto,
edera e felce
Real eucalyptus, ivy
and fern leave



Foglie stabilizzate che non
cambiano nel tempo
Stabilized leaves that do
not change over time



Non necessita di
manutenzione e acqua
Requires no maintenance
and water



Fonoassorbente
Sound-absorbing



GAVIN SILENCE LEAF

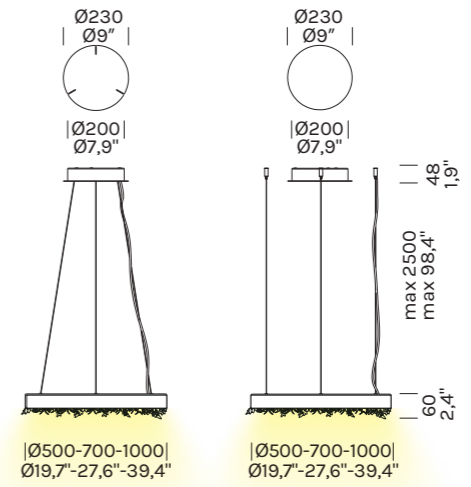

Lampada fonoassorbente
Ferro, vere foglie stabilizzate

Soundabsorbing lamp
Iron, real stabilized leaves

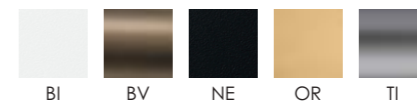

EXAGON *Collection*

SOSPENSIONE ESAGONALE BI-EMISSIONE,
DISPONIBILE ANCHE IN VERSIONE FONOASSORBENTE

HEXAGONAL BI-EMISSION PENDANT LIGHT, ALSO
AVAILABLE IN A SOUND-ABSORBING VERSION



FIND OUT
ON OUR
WEBSITE



Design Filippo Cannata & OLEV Design Lab

Registered Design



EXAGON

Lampada esagonale che emette luce
sia verso l'alto sia verso il basso
Hexagonal lamp that emits light
upwards and downwards



EXAGON SILENCE

Lampada fonoassorbente
con lamierino microforato
Soundabsorbing Lamp
with micro-perforated metal sheet



EXAGON SILENCE *Green*

Lampada fonoassorbente
con licheni
Soundabsorbing Lamp
with lichens



EXAGON SILENCE *Biolight*

Lampada fonoassorbente
con tecnologia Biolight
Soundabsorbing Lamp
with Biolight technology

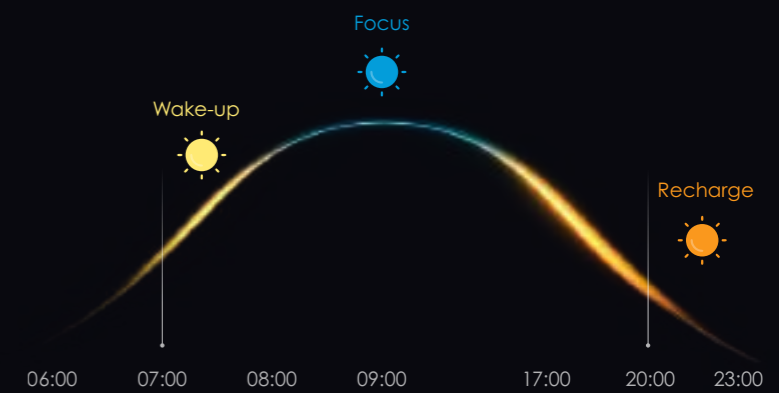
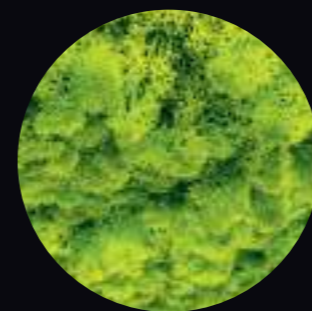

EXAGON SILENCE

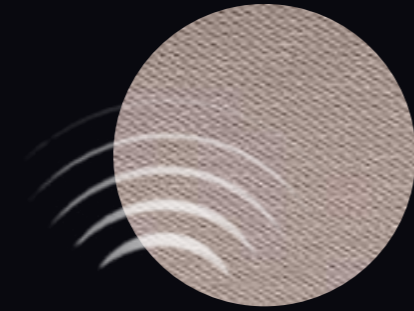
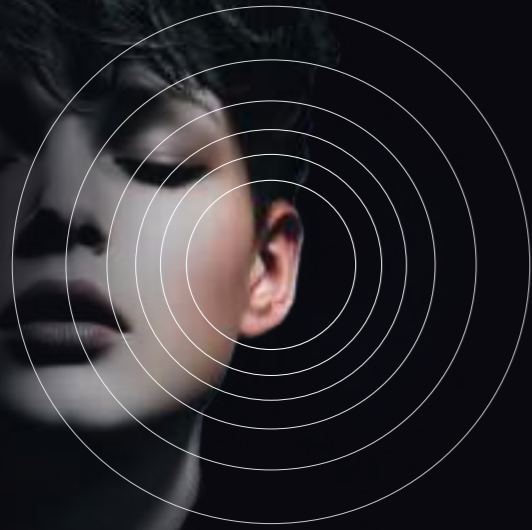

Il suo pannello interno in lamierino microforato permette di assorbire i rumori migliorando il comfort acustico dell'ambiente.

Its internal micro-perforated sheet metal panel absorbs noise, significantly enhancing the acoustic comfort of the room.

EXAGON SILENCE *Green*

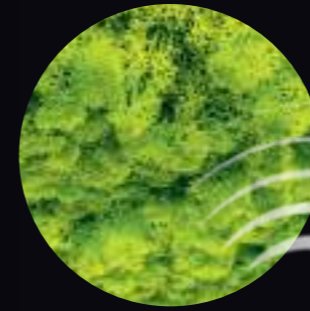

Il suo pannello interno in llichene scandinavo naturale e stabilizzato, permette di assorbire i rumori migliorando il comfort acustico dell'ambiente.

Its internal panel, made of natural stabilized Scandinavian lichen, absorbs noise while enhancing the acoustic comfort of the room.



Lichene stabilizzato che non cambia nel tempo
Stabilized lichen that does not change over time



Ostili per la riproduzione di insetti
Hostile environment for the insects



Non necessita di manutenzione e acqua
Requires no maintenance and water



Fonoassorbente
Sound-absorbing



EXAGON SILENCE *Biolight*



Assorbe i rumori mentre riproduce le variazioni della luce del Sole, ricreando la stessa sensazione di benessere che si proverebbe in un ambiente naturale esterno. Inoltre, imitando la luce del sole, rispetta il nostro biologico ritmo circadiano di sonno e veglia durante la giornata.

It absorbs noise while replicating the shifting patterns of sunlight, recreating the same sense of well-being found in nature. Furthermore, by mimicking natural light, it honors our biological circadian rhythm, supporting a healthy sleep-wake cycle throughout the day.



EXAGON

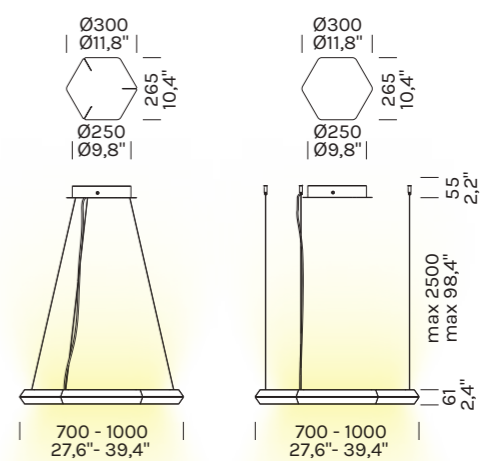
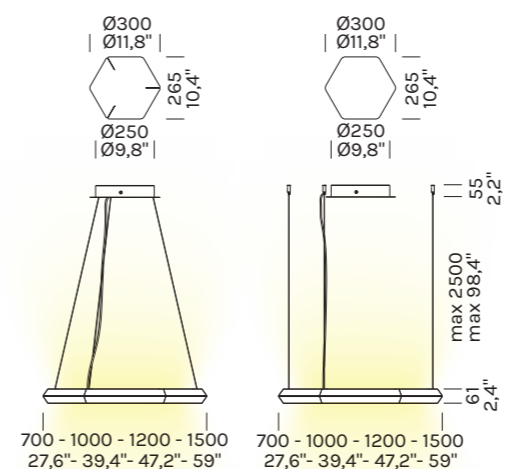

EXAGON SILENCE
EXAGON SILENCE *Green*
EXAGON SILENCE *Biolight*

Alluminio
Aluminum



BR

POLY ESAGONO

DOPPIA SORGENTE LUMINOSA,
VERSO L'ALTO E IL BASSO

DOUBLE LIGHT SOURCE,
UPWARD AND DOWNWARD

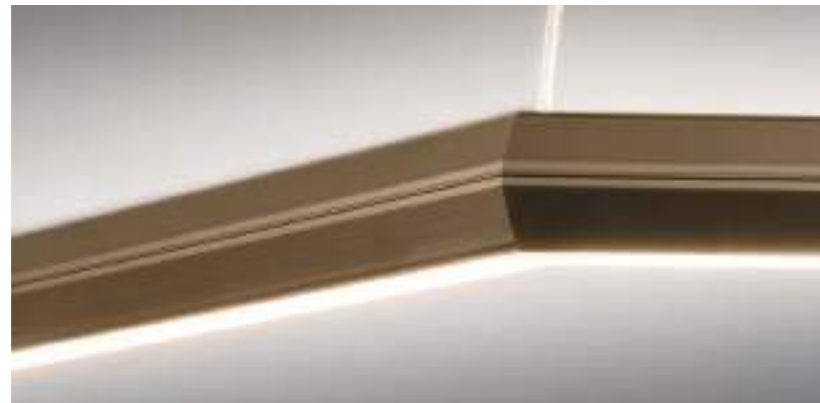

FIND OUT
ON OUR
WEBSITE



Design Michele Marcon

Registered Design



POLY ESAGONO

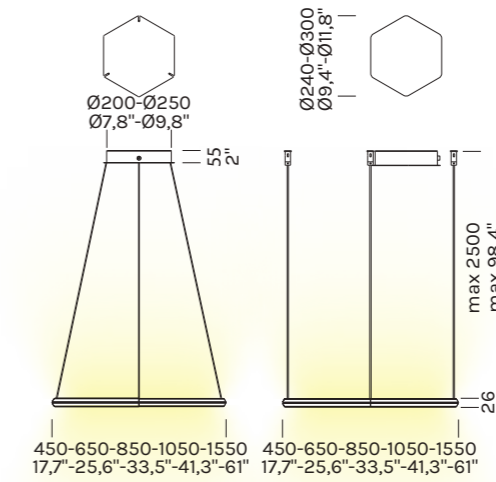

Alluminio
Aluminum

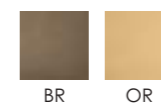

POLY LINEAR

SEZIONE ESAGONALE
CON DOPPIA SORGENTE DI LUCE

HEXAGONAL SECTION
WITH DOUBLE LIGHT SOURCE

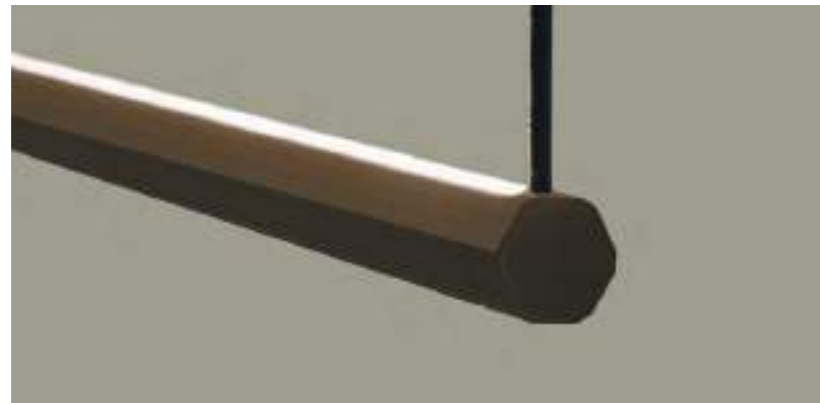

Design Michele Marcon
Registered Design



POLY LINEAR

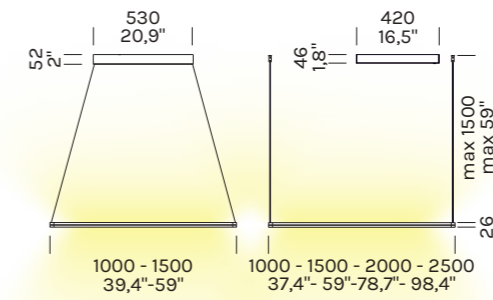

Alluminio
Aluminum



BR

TRISEL

VETRO CANNETTATO
CHE FILTRA DOLCEMENTE LA LUCE

FLUTED GLASS
THAT SOFTLY FILTERS THE LIGHT



FIND OUT
ON OUR
WEBSITE



Design _blank design studio

Registered Design





TRISEL

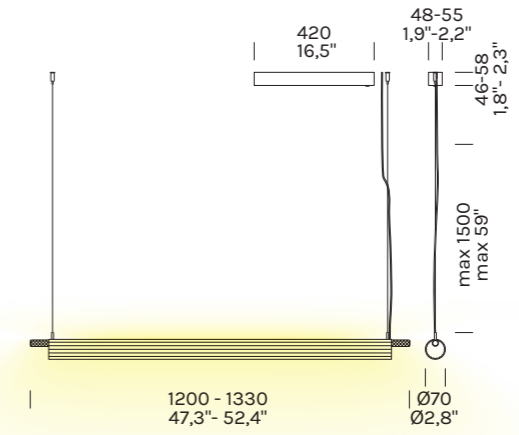

Alluminio, vetro borosilicato
Aluminum, borosilicate glass

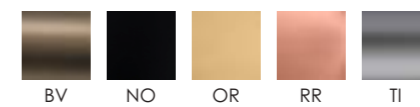

BEAM STICK GLASS

VETRO BOROSILICATO
LAVORATO A MANO

HAND-WORKED
BOROSILICATE GLASS



Design Marc Sadler
Registered Design





BEAM STICK GLASS

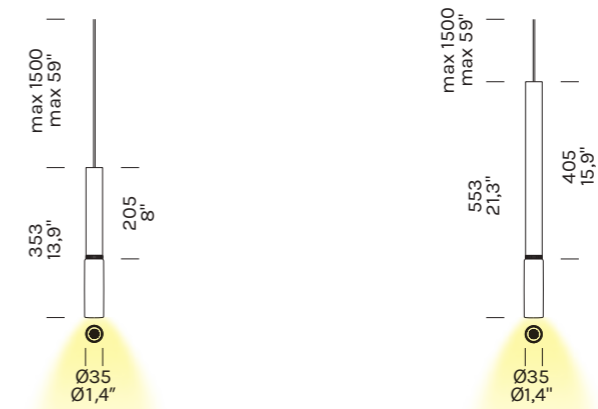

Rosoni a soffitto Canopies

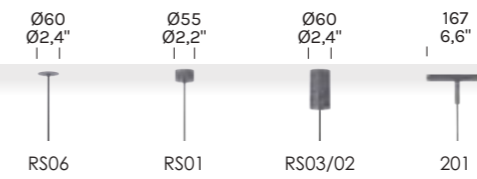

Alluminio e vetro Aluminum and glass

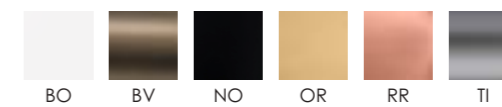

BEAM STICK METAL *Collection*

LUCE FILTRATA
PER ESSERE CONFORTEVOLE ALLA VISTA

FILTERED LIGHT
TO BE COMFORTABLE TO THE EYE



Design Marc Sadler
Registered Design



Corpo Body	Bianco superOpaco Super-matt white	Titanio Titanium	Nero superOpaco Super-matt black	Brunito verniciato Painted burnished	Oro ricco Rich gold	Rame rosa Pink copper
Ghiera Ring	Nero superOpaco Super-matt black	Nero superOpaco Super-matt black	Oro ricco Rich gold	Oro ricco Rich gold	Oro ricco Rich gold	Nero superOpaco Super-matt black

BEAM STICK METAL Ø35

BEAM STICK METAL Ø 35 H 200
BEAM STICK METAL Ø 35 H 400



COMFORT VISIVO

Il fascio luminoso è addolcito dal filtro a nido d'ape che elimina qualsiasi riflesso o bagliore indesiderato. Questo rende la luce morbida e assicura un comfort ottimale per i nostri occhi.

VISUAL COMFORT

The light emission is diffused by the honeycomb filter, eliminating any glare or stray light. This results in a gentle illumination that guarantees maximum visual comfort.



Ø35

BEAM STICK METAL Ø60

BEAM STICK METAL Ø 60 H 200
BEAM STICK METAL Ø 60 H 400



COMFORT VISIVO

Il fascio luminoso è addolcito dal filtro a nido d'ape che elimina qualsiasi riflesso o bagliore indesiderato. Questo rende la luce morbida e assicura un comfort ottimale per i nostri occhi.

VISUAL COMFORT

The light emission is diffused by the honeycomb filter, eliminating any glare or stray light. This results in a gentle illumination that guarantees maximum visual comfort.



Ø60

BEAM STICK METAL Ø80

BEAM STICK METAL Ø 80 H 80



COMFORT VISIVO

Il fascio luminoso è addolcito dal filtro a nido d'ape che elimina qualsiasi riflesso o bagliore indesiderato. Questo rende la luce morbida e assicura un comfort ottimale per i nostri occhi.

VISUAL COMFORT

The light emission is diffused by the honeycomb filter, eliminating any glare or stray light. This results in a gentle illumination that guarantees maximum visual comfort.



Ø80



BEAM STICK METAL COLLECTION

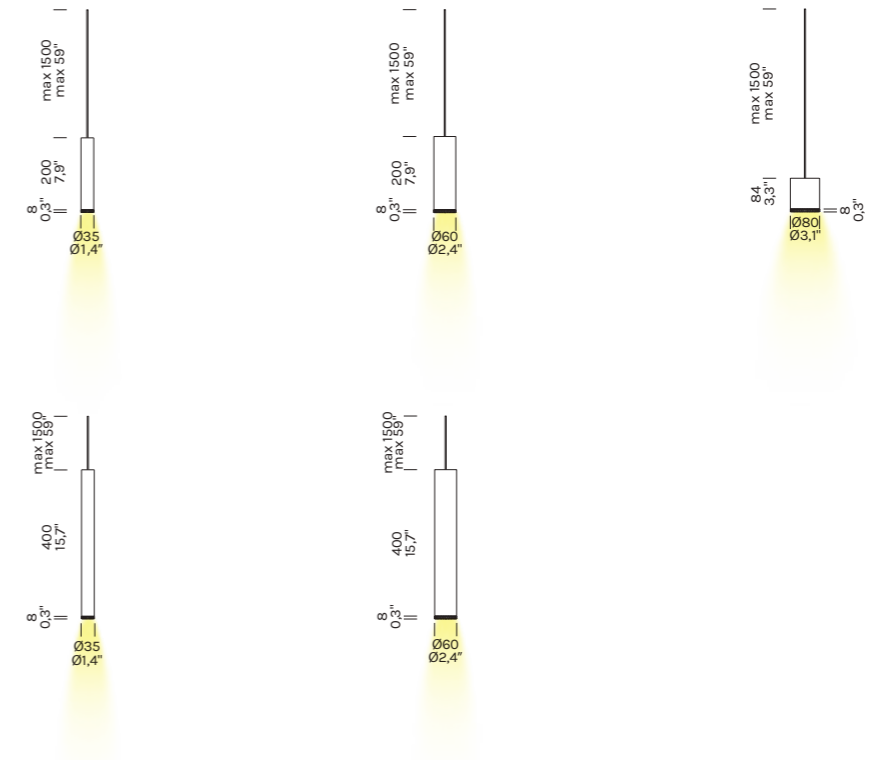

Rosoni a soffitto Canopies

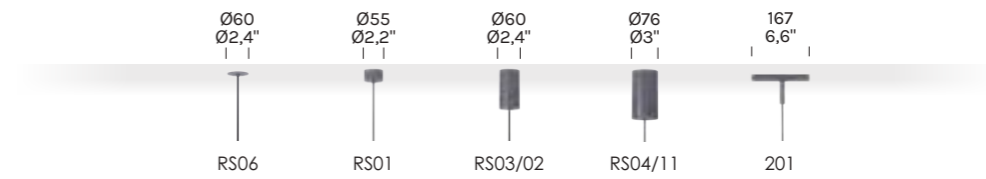

Alluminio Aluminum

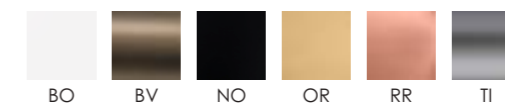

LIKESHADE

PROFILO IN OTTONE CON MORBIDE RIGATURE,
VERNICIATO A MANO

BRASS PROFILE WITH SOFT GROOVES,
PAINTED BY HAND



Design Andrea Lanaro

Registered Design



COMFORT VISIVO

Il fascio luminoso è addolcito dal filtro a nido d'ape che elimina qualsiasi riflesso o bagliore indesiderato. Questo rende la luce morbida e assicura un comfort ottimale per i nostri occhi.

VISUAL COMFORT

The light emission is diffused by the honeycomb filter, eliminating any glare or stray light. This results in a gentle illumination that guarantees maximum visual comfort.

LIKESHADE

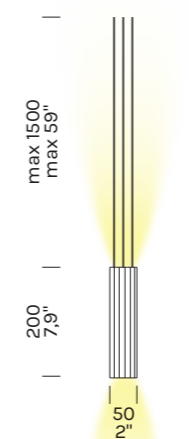

Rosoni a soffitto Canopies

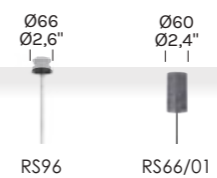

Ottone Brass



SHINE VERTICAL *Plumage*

REALIZZATO IN OTTONE
CON SEZIONE ESAGONALE

MADE OF BRASS
WITH HEXAGONAL SECTION



Design Michele Marcon
Registered Design



SHINE VERTICAL



SHINE VERTICAL *Plumage*

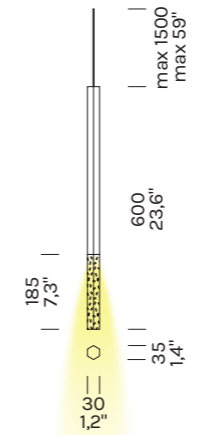

SHINE VERTICAL

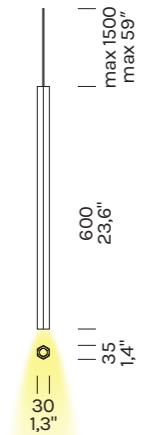

Rosoni a soffitto
Canopies

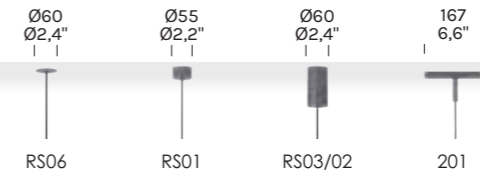

Ottone, plexiglass, piume decorative
Brass, plexiglass, decorative feathers

Ottone
Brass



LONGUETTE



Design OLEV Design Lab

Registered Design

FIND OUT
ON OUR
WEBSITE



Restaurant Atelier Moessmer Norbert Niederkofler,
Brunico, Italy (Michelin-starred restaurant)
Photo: Lorenzo Polato, Dalge, Paolo Riolzi, Markus Ranalter



Restaurant Atelier Moessmer Norbert Niederkofler,
Brunico, Italy (Michelin-starred restaurant)
Photo: Lorenzo Polato, Dalge, Paolo Riolzi, Markus Rantalter



LONGUETTE

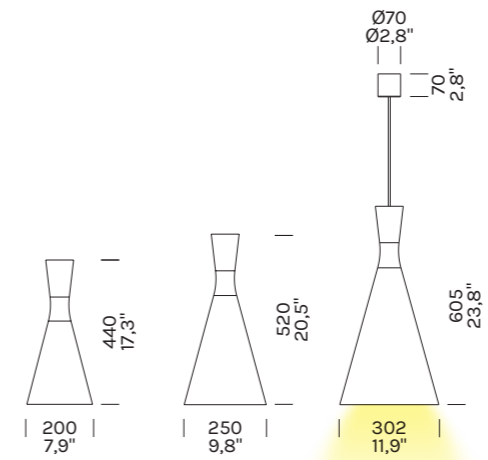

Alluminio
 Aluminum



MERCEDES

FILTRO PRISMATICO
PER UN ELEVATO COMFORT VISIVO

PRISMATIC FILTER
FOR HIGH VISUAL COMFORT



Design OLEV Design Lab
Registered Design



MERCEDES

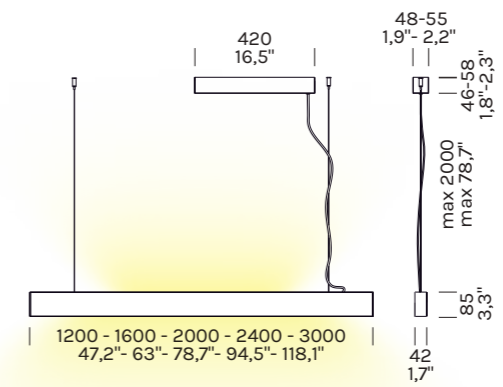

Alluminio
Aluminum



NG

MEETING SILENCE LEAF

FONOASSORBENTE
CON VERE FOGLIE STABILIZZATE

SOUND ABSORBING LAMP
WITH REAL STABILIZED LEAVES



Design OLEV Design Lab
Registered Design

MEETING SILENCE LEAF



Vere foglie di eucalipto, edera e felce

Real eucalyptus, ivy and fern leave



Foglie stabilizzate che non cambiano nel tempo

Stabilized leaves that do not change over time



Non necessita di manutenzione e acqua

Requires no maintenance and water



Fonoassorbente

Sound-absorbing



MEETING SILENCE LEAF

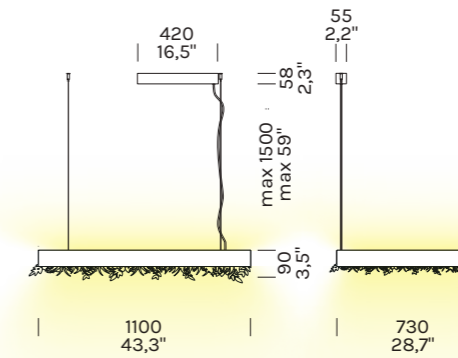

Lampada fonoassorbente
Alluminio, vere foglie stabilizzate

Soundabsorbing lamp
Aluminum, real stabilized leaves



NG

LANACOTTA

VERO LEGNO DI ROVERE NATURALE

GENUINE NATURAL OAK



Design Carlo Cappellotto

Registered Design





LANACOTTA

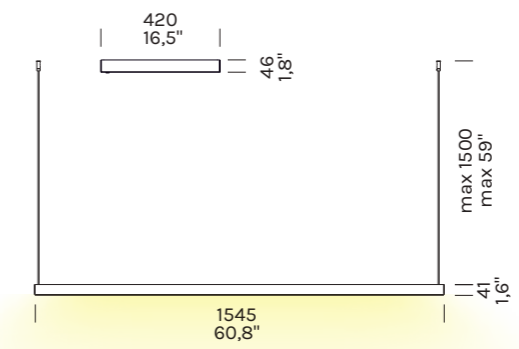

Legno rovere
Durmast wood



LRV

LA PALLINA SP

LO STELO È IMPREZIOSITO
DA INCISIONI GEOMETRICHE

THE STEM IS EMBELLISHED
WITH GEOMETRIC ENGRAVINGS



Design OLEV Design Lab

Registered Design



FIND OUT
ON OUR
WEBSITE





LA PALLINA SP

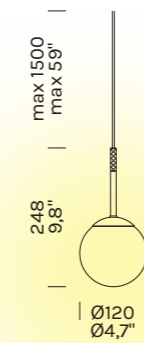

Rosoni a soffitto
Canopies

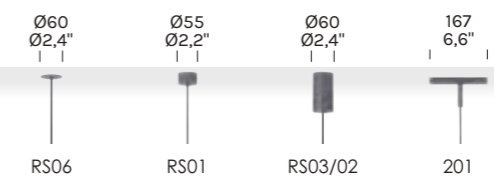

Alluminio, vetro soffiato a bocca
Aluminum, mouth-blown glass



INDOOR

INDOOR
**LAMPADE DA
SOFFITTO & PARETE**

**CEILING &
WALL LAMPS**

DOOR

ASTRELLE *Ellix* AP

VETRO SOFFIATO A BOCCA
CON EFFETTO ALABASTRO

MOUTH-BLOWN GLASS WITH
ALABASTER FINISH



FIND OUT
ON OUR
WEBSITE



Design Marc Sadler

Registered Design



ALLUNGABILE E ADATTABILE
Un semplice movimento per portare la luce
esattamente dove serve.

EXTENDABLE & ADAPTABLE
A simple gesture to bring light
exactly where it's needed.



COMFORT VISIVO

Il fascio luminoso è addolcito dal filtro a nido d'ape che elimina qualsiasi riflesso o bagliore indesiderato. Questo rende la luce morbida e assicura un comfort ottimale per i nostri occhi.

VISUAL COMFORT

The light emission is diffused by the honeycomb filter, eliminating any glare or stray light. This results in a gentle illumination that guarantees maximum visual comfort.

ASTRELLE *Ellix* AP

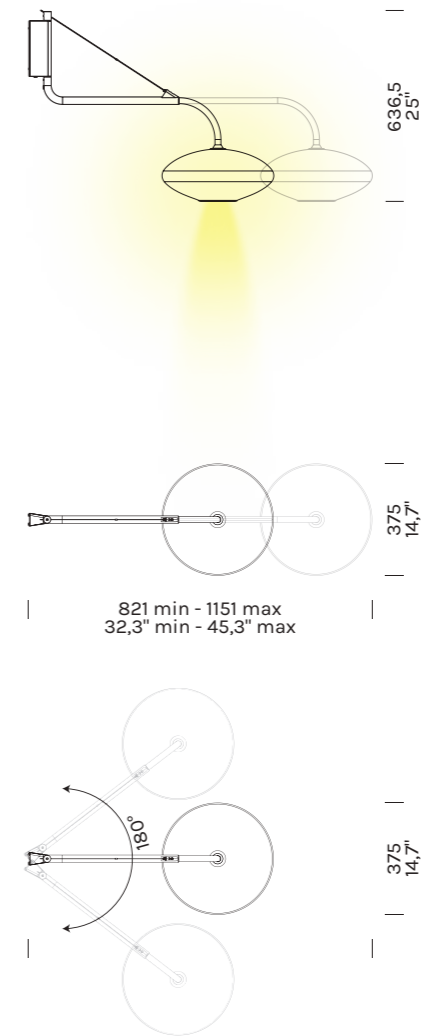

Ferro, alluminio, vetro soffiato a bocca
Iron, aluminum, mouth-blown glass



ANE FS

ASTRELLE *Global* AP

VETRO SOFFIATO A BOCCA
CON EFFETTO ALABASTRO

MOUTH-BLOWN GLASS WITH
ALABASTER FINISH



FIND OUT
ON OUR
WEBSITE



Design Marc Sadler
Registered Design





COMFORT VISIVO

Il fascio luminoso è addolcito dal filtro a nido d'ape che elimina qualsiasi riflesso o bagliore indesiderato. Questo rende la luce morbida e assicura un comfort ottimale per i nostri occhi.

VISUAL COMFORT

The light emission is diffused by the honeycomb filter, eliminating any glare or stray light. This results in a gentle illumination that guarantees maximum visual comfort.

ASTRELLE *Global AP*

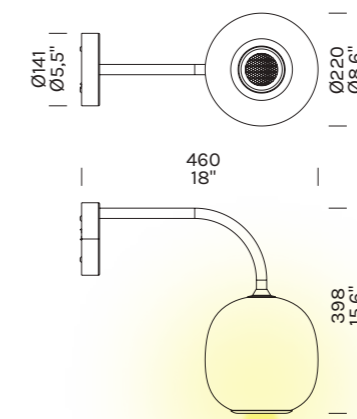

Ferro, alluminio, vetro soffiato a bocca
Iron, aluminum, mouth-blown glass



ANE FS

CURUBA PL

VETRO SOFFIATO A BOCCA
CON TEXTURE TRIDIMENSIONALE

MOUTH-BLOWN GLASS
WITH A THREE-DIMENSIONAL TEXTURE



FIND OUT
ON OUR
WEBSITE



Design Andrea Lanaro

Registered Design





CURUBA PL

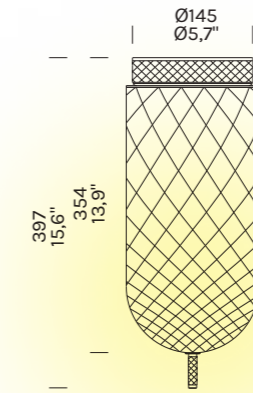

Alluminio e vetro soffiato a bocca
Aluminum and mouth-blown glass



ORNATO

SISTEMA MODULARE
E COMPONIBILE

MODULAR AND
CONFIGURABLE SYSTEM



LUCE INDIRETTA
La fonte di luce è invisibile ad occhio nudo,
generando una piacevole illuminazione indiretta.

INDIRECT LIGHTING
The light source is invisible,
generating a pleasant indirect lighting.



Design Lo Studio Mammini Candido





ORNATO

Versione a soffitto
Ceiling version

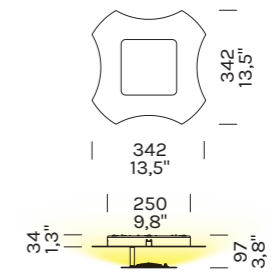
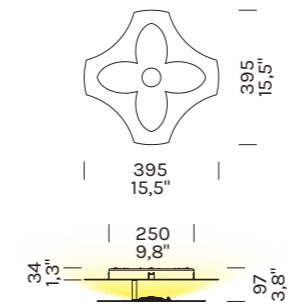

Versione a binario
Track version

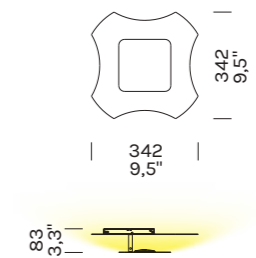
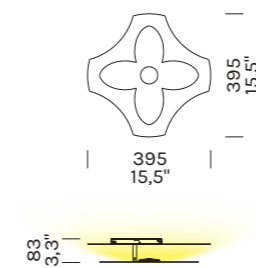

Alluminio
Aluminum

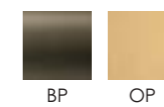

OTTOMANO

ERGONOMICO
E CON FONTE DI LUCE
SIA VERSO L'ALTO SIA VERSO IL BASSO

ERGONOMIC
AND WITH LIGHT SOURCE BOTH
UPWARDS AND DOWNWARDS



Ottomano achieves in 2020 the honorable mention at European Product Design Award.

FIND OUT
ON OUR
WEBSITE



Design Michele Marcon

Registered Design





190



191



OTTOMANO

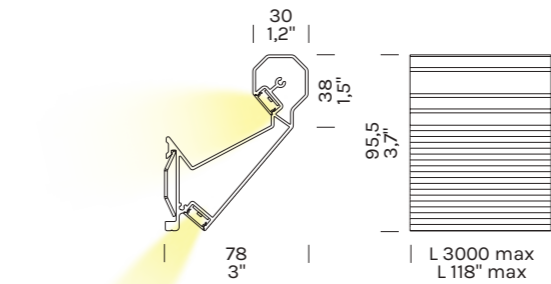

Alluminio
Aluminum

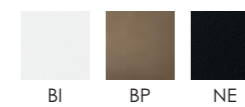

TRISEL AP

VETRO CANNETTATO
CHE FILTRA DOLCEMENTE LA LUCE

FLUTED GLASS
THAT SOFTLY FILTERS THE LIGHT



FIND OUT
ON OUR
WEBSITE



Design _blank design studio

Registered Design



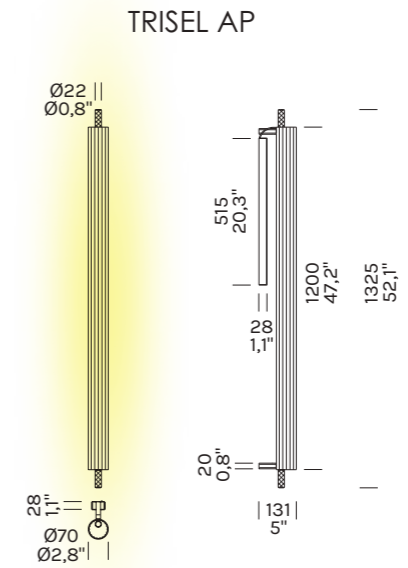

Alluminio, vetro borosilicato
Aluminum, borosilicate glass

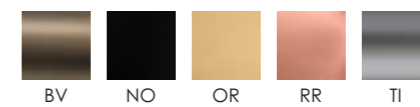

CHARMER AP

FINITURE SUPER MATT
OTTENUTE CON VERNICIATURA A MANO

SUPER-MATT FINISHES ACHIEVED
THROUGH HAND-PAINTING



Design Benedetta Nicolich
Registered Design



CHARMER AP

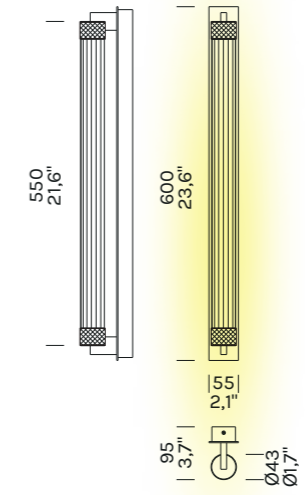

Ferro, vetro borosilicato
Iron, borosilicate glass



POLY ESAGONO PL

LAMPADA ESAGONALE NELLA FORMA
E NELLA SEZIONE DEL PROFILO
CON ILLUMINAZIONE INDIRETTA

LAMP WITH HEXAGONAL
SHAPE AND PROFILE SECTION
WITH INDIRECT LIGHTING



Design Michele Marcon
Registered Design





POLY ESAGONO PL

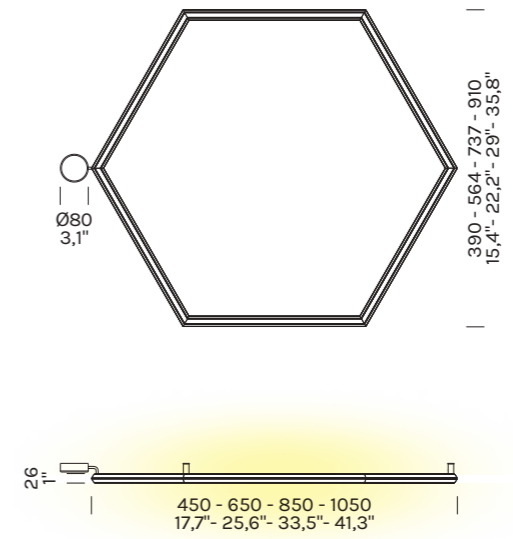

Alluminio
Aluminum

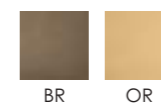

OVERFLY PLUS PL

FINITURE SUPER MATT
OTTENUTE CON VERNICIATURA A MANO

SUPER-MATT FINISHES ACHIEVED
THROUGH HAND-PAINTING



FIND OUT
ON OUR
WEBSITE



Design Marc Sadler
Registered Design







OVERFLY PLUS PL

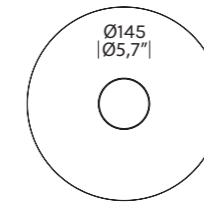
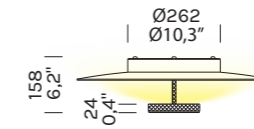

Ø550 - Ø750
Ø21,7" - Ø29,5"

Alluminio, plexiglass
Aluminium, plexiglass



BM

BO

FLUENTIS

DISCO LUMINOSO CON ORIENTAMENTO
LIBERO DELLA LUCE

LUMINOUS DISC WITH ADJUSTABLE
LIGHT DIRECTION



FIND OUT
ON OUR
WEBSITE



Design OLEV Design Lab



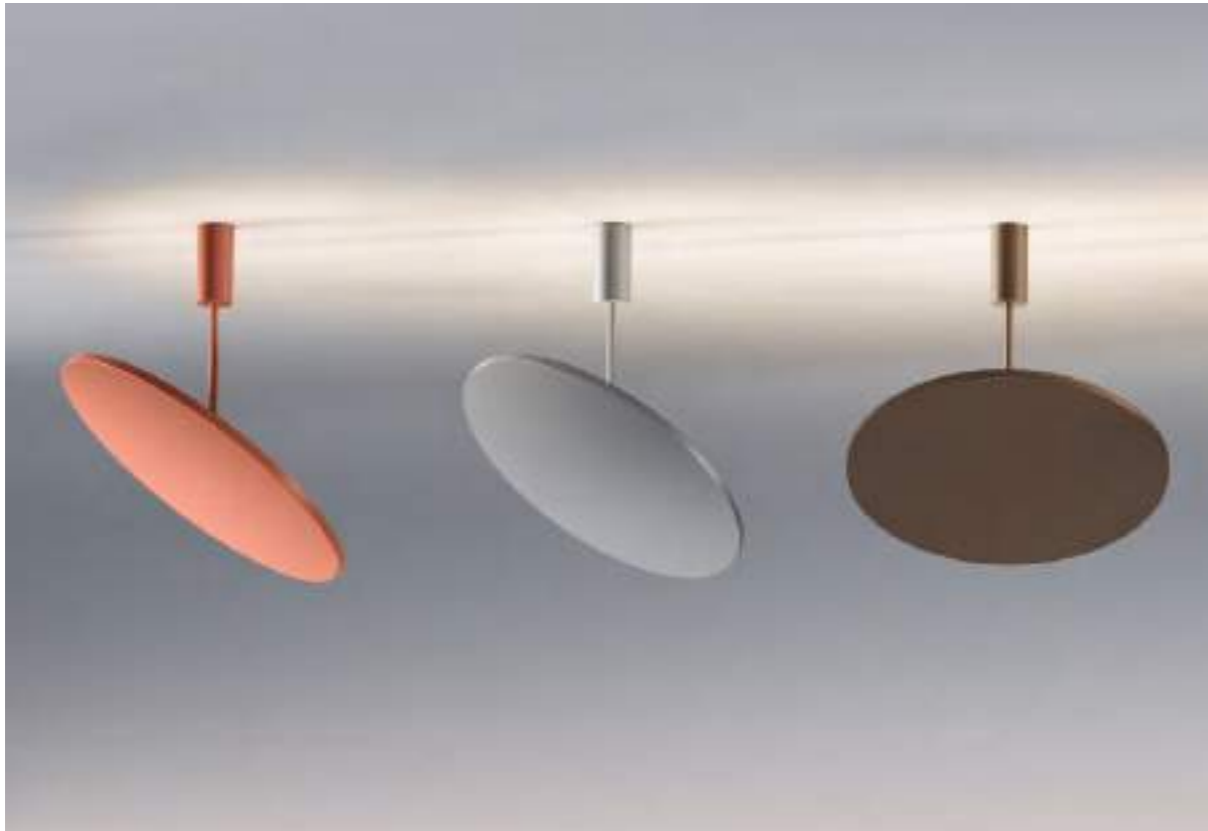

FLUENTIS

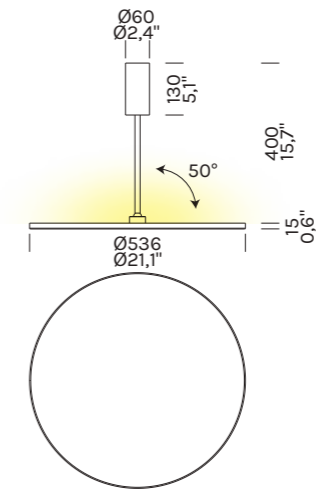

Ferro, plexiglass
Iron, plexiglass

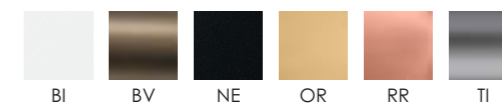

KINETIKA

PIATTO LUMINOSO CON
ORIENTAMENTO LIBERO DELLA LUCE

LUMINOUS PLATE WITH
ADJUSTABLE LIGHT ORIENTATION



Design Marc Sadler
Registered Design



KINETIKA

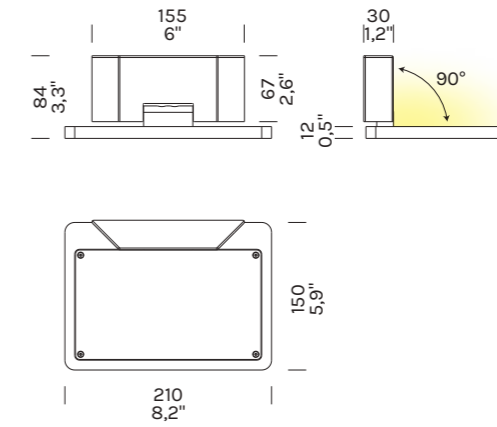

Alluminio, ferro, plexiglass
Aluminum, iron, plexiglass

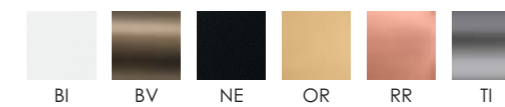

TUBELIA

FORME MORBIDE
CON LUCE VERSO L'ALTO E IL BASSO

SOFT-SHAPED LAMP
WITH UP-AND-DOWN LIGHT



Design Sara Moroni
Registered Design



TUBELIA

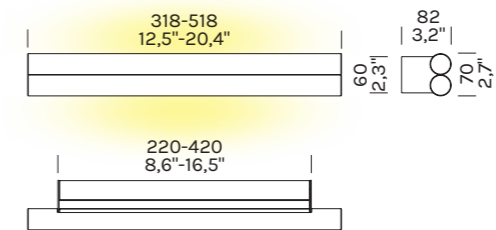

Alluminio
Aluminum

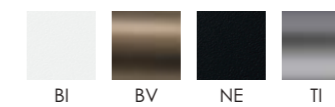

BEAM MASTER *Collection*

FASCIO DI LUCE ORIENTABILE,
AMPIA GAMMA DI MISURE

ADJUSTABLE BEAM ANGLE,
AVAILABLE IN A WIDE RANGE OF SIZES



FIND OUT
ON OUR
WEBSITE



Design Marc Sadler
Registered Design



BEAM MASTER Ø25



BEAM MASTER Ø25 BUILT-IN



BEAM MASTER Ø35



BEAM MASTER Ø25

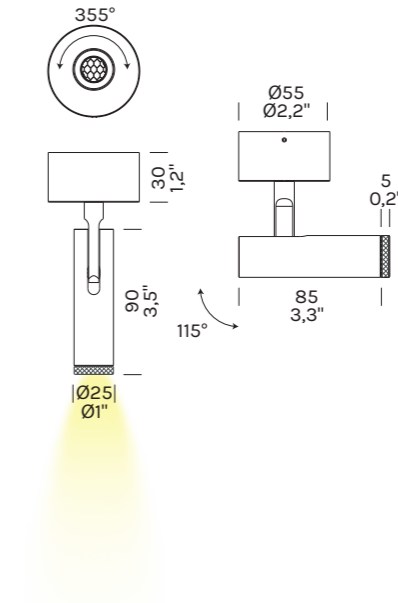
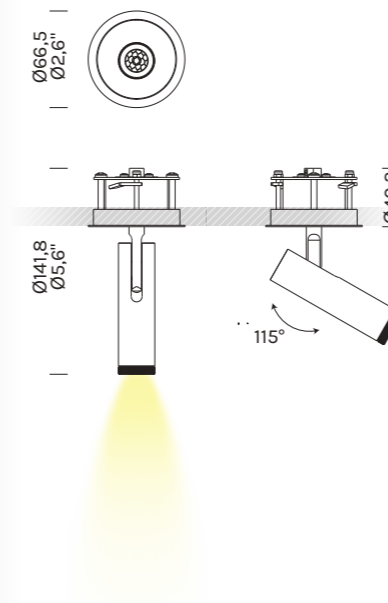

BEAM MASTER Ø25 BUILT-IN

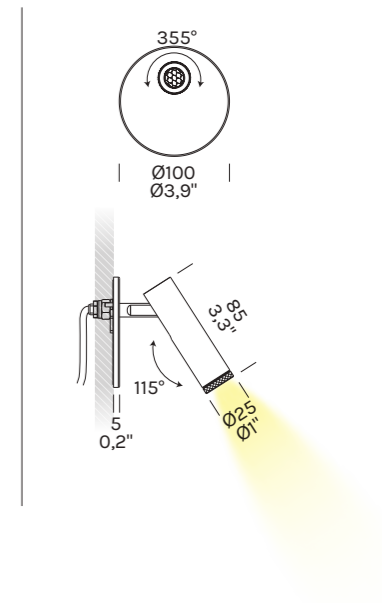

BEAM MASTER Ø35

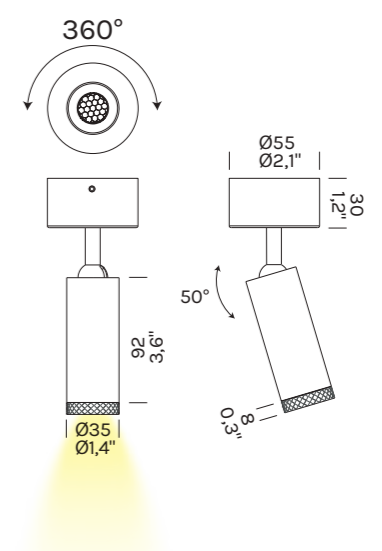
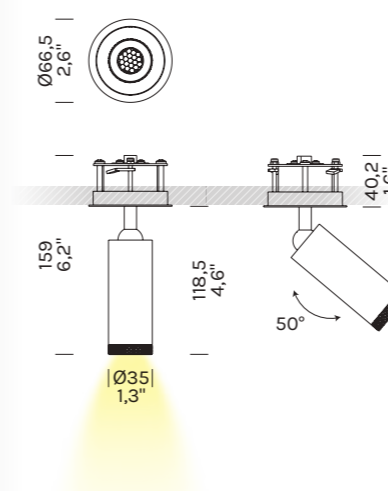

Alluminio
Aluminum



BEAM MASTER Ø60



BEAM MASTER Ø80



BEAM MASTER Ø60

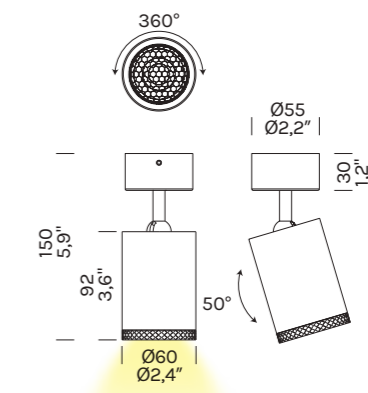
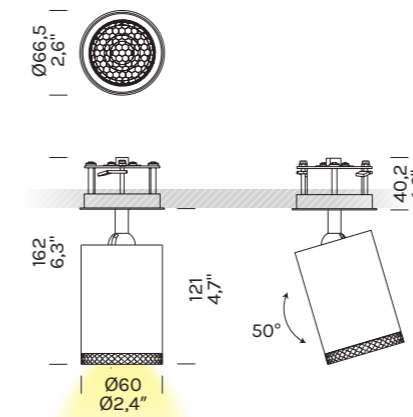

BEAM MASTER Ø80

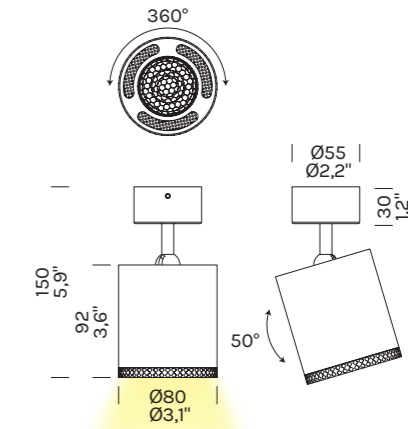
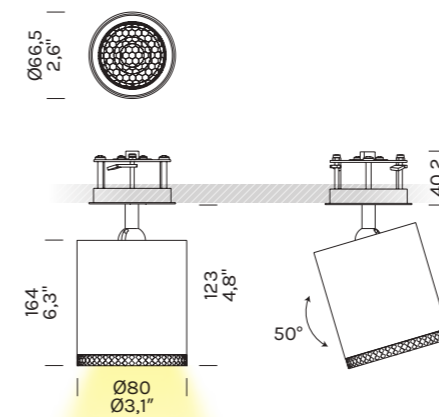

Alluminio
Aluminum



BEAM MASTER Ø60 ZUMMY

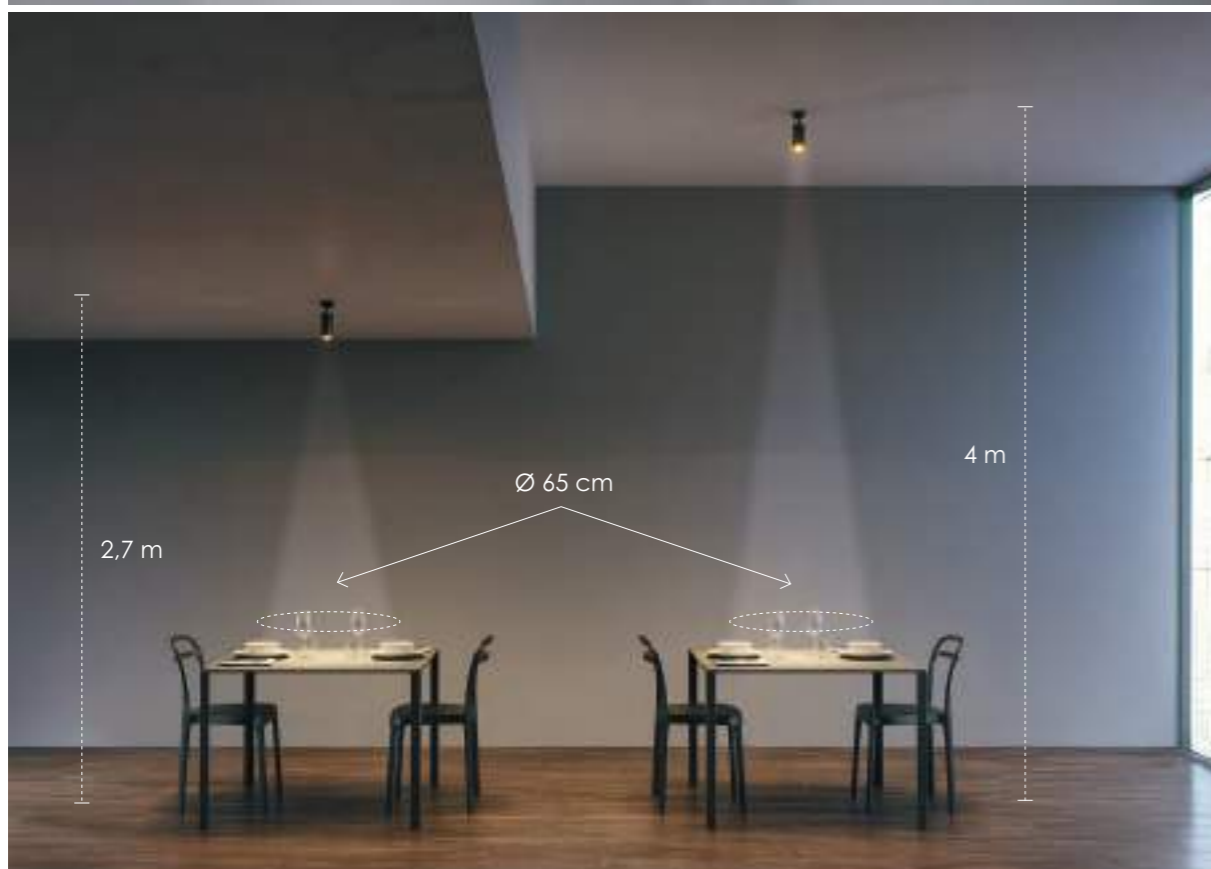

BEAM MASTER Ø60 ZUMMY

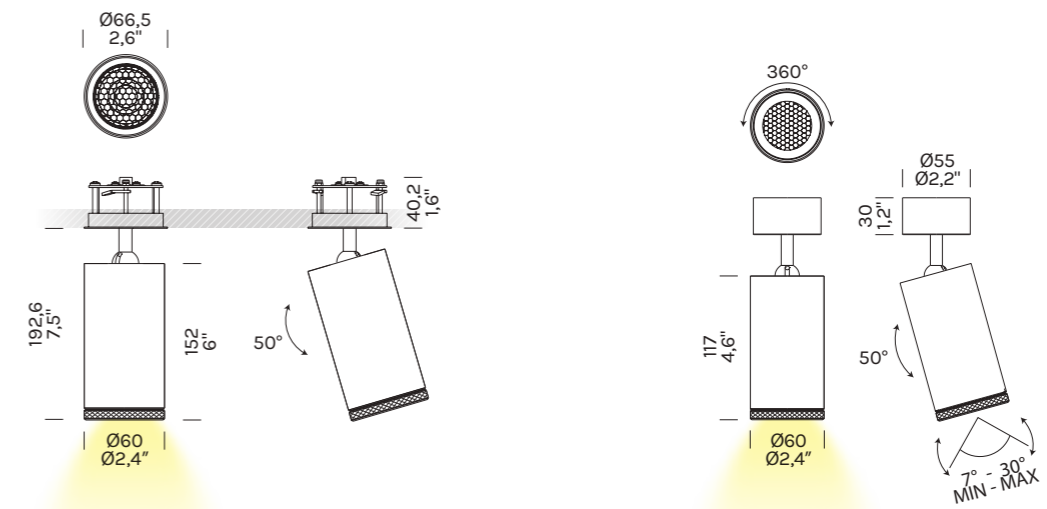

Beam Master 60 Zummy è un faretto orientabile con fascio di luce regolabile. Ruotando la ghiera è possibile infatti mantenere costante la larghezza del fascio luminoso anche se la lampada è posta a diverse altezze di soffitto.

Beam Master 60 Zummy is an adjustable spotlight with adjustable light beam. By turning the ring it's possible to keep the width of the light beam constant even if the lamp is placed at different ceiling heights.

Alluminio
Aluminum



EYE *Collection*

PICCOLI GIOIELLI DI LUCE
CON FASCIO LUMINOSO CONFORTEVOLE

SMALL JEWELS OF LIGHT
WITH A COMFORTABLE LIGHT BEAM



FIND OUT
ON OUR
WEBSITE



Design Filippo Cannata
Registered Design



EYE SPOT



EYE SPOT BUILT-IN



EYE SPOT 230V



EYE SPOT

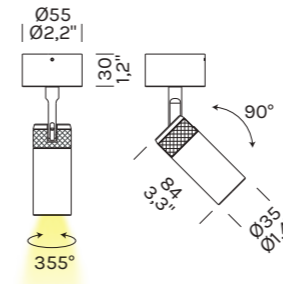

EYE SPOT BUILT-IN

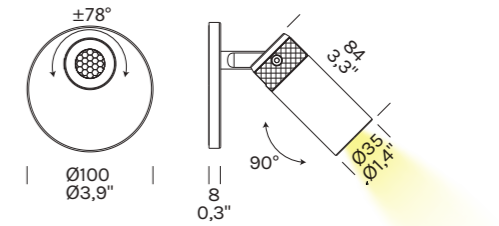

EYE SPOT 230V

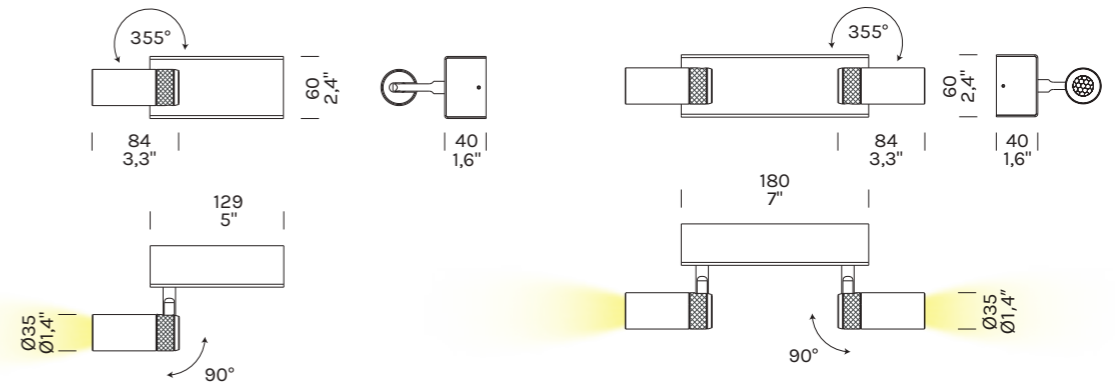

Alluminio
Aluminum



BO

BV

NO

OR

TI

SHINE SPOT *Collection*



FIND OUT
ON OUR
WEBSITE



Design OLEV Design Lab
Registered Design



SHINE SPOT



SHINE SPOT 230V



SHINE SPOT

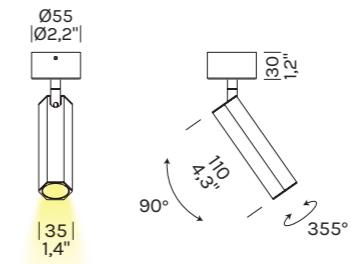

SHINE SPOT 230V

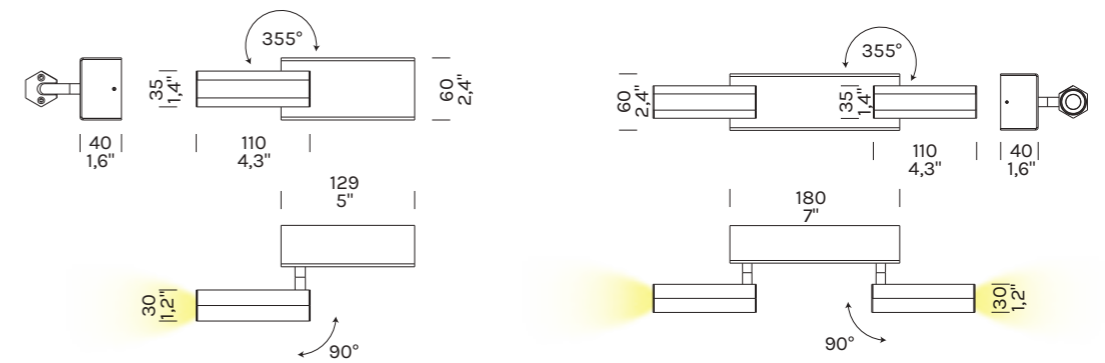

Ottone
Brass

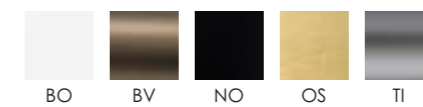

OLORFLEX

BRACCIO FLESSIBILE
RIVESTITO IN MORBIDO TESSUTO

FLEXIBLE ARM
COVERED IN SOFT FABRIC



FIND OUT
ON OUR
WEBSITE





OLORFLEX

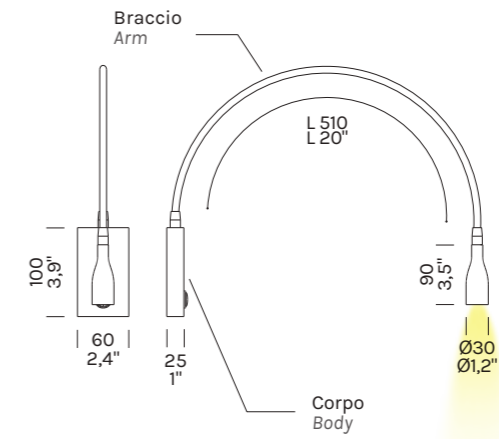

Ferro, tessuto
Iron, fabric

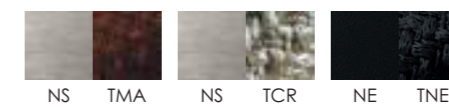

SHINE PLUMAGE AP



Design Michele Marcon



SHINE PLUMAGE AP

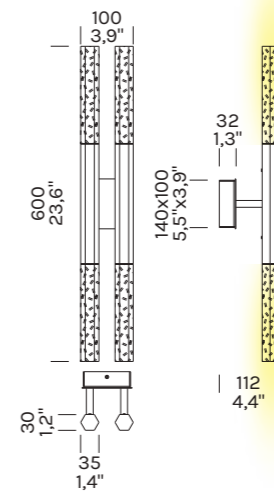

Ottone, plexiglass,
piume decorative

Brass, plexiglass,
decorative feathers



SLIGHT AP



Design Massimo Tonetto
Registered Design



SLIGHT AP

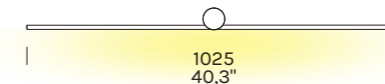
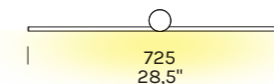

Alluminio
Aluminium

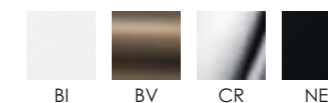

TIMELINE



Design OLEV Design Lab
Registered Design



TIMELINE

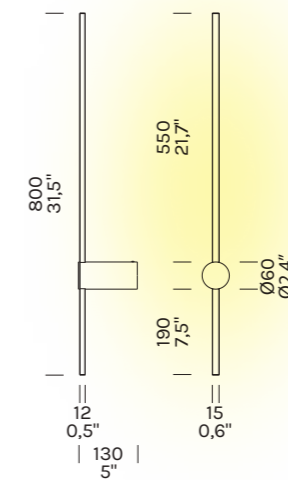

Alluminio, ferro
Aluminum, iron

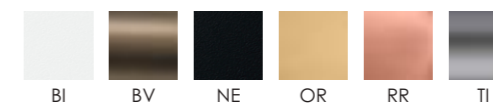

ZEN



Design OLEV Design Lab



ZEN

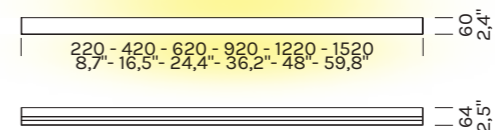

Alluminio
Aluminum

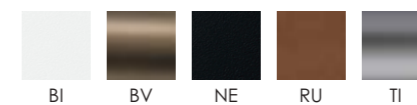

TAB LED



Design OLEV Design Lab



TAB LED

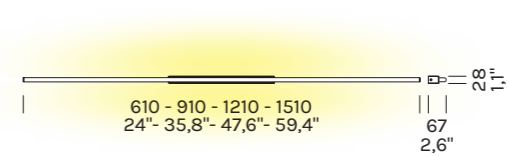

Ferro
Iron



MERCEDES PL



Design OLEV Design Lab



MERCEDES PL

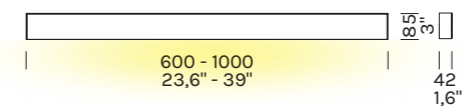

Alluminio, policarbonato
Diffusore microprismatico

Aluminum, polycarbonate
Microprismatic diffuser

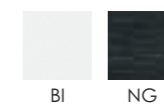

LA PALLINA AP



Design Beppe Tizian
Registered Design



LA PALLINA AP

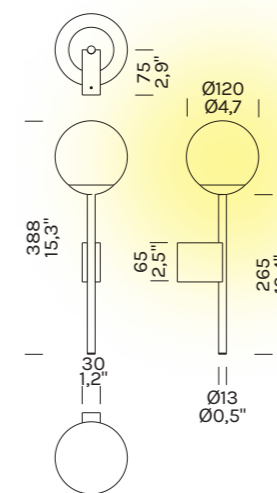

Alluminio e vetro soffiato a bocca
Aluminum and mouth-blown glass



PIPE PL



Design OLEV Design Lab



PIPE PL



Ferro
Iron

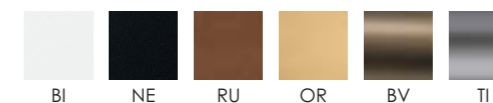

TURN



Design OLEV Design Lab



TURN

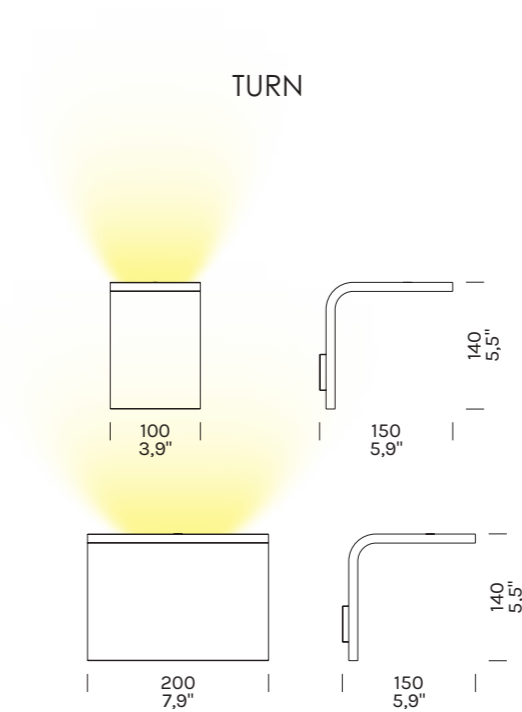

Alluminio
Aluminum

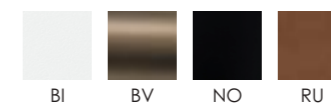

INDOOR

INDOOR
**LAMPADE DA
SOFFITTO INCASSO**
RECESSED
CEILING LAMPS

DOOR

OR

TINY *Collection*

PICCOLE DIMENSIONI,
ELEVATA POTENZA

SMALL DIMENSIONS,
HIGH-POWER



Design Filippo Cannata





Direziona la luce dove preferisci: il filtro a nido d'ape elimina riflessi e abbagliamenti, trasformando il fascio luminoso in una fonte morbida e piacevole per gli occhi.

Point the light exactly where you need it. The honeycomb filter eliminates reflections and glare, transforming the beam into a soft, eye-friendly light source.

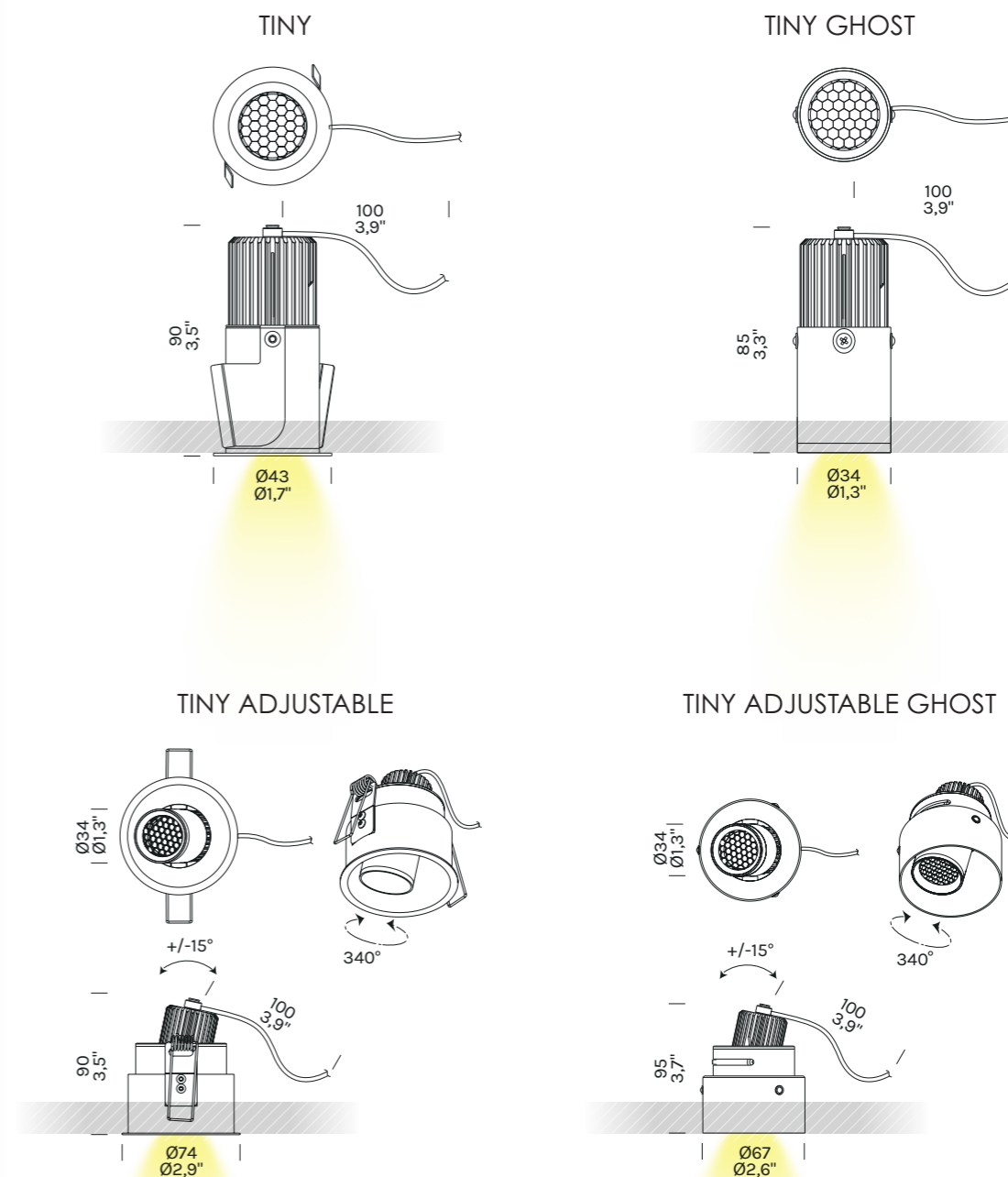

Alluminio
Aluminum

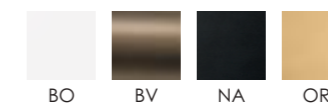

INDOOR
LAMP
DA TAVOLO
TABLE LAMPS

ANTARTIC

VETRO SOFFIATO A BOCCA
E LAVORATO A MANO

MOUTH-BLOWN
AND HAND-WORKED GLASS



FIND OUT
ON OUR
WEBSITE



Design Marc Sadler

Registered Design



Il paralume in vetro può essere posizionato a piacere per orientare la luce.

The glass lampshade can be positioned as you wish to direct the light.



FIND OUT
ON OUR
WEBSITE



ANTARTIC

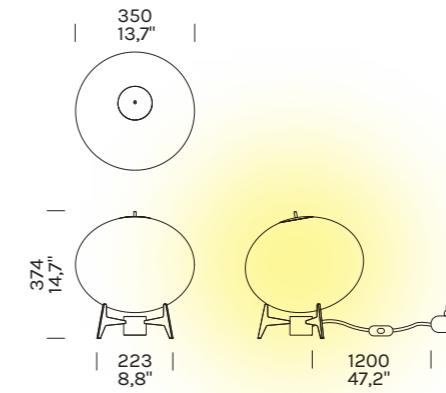

Vetro soffiato a bocca e ferro
Mouth-blown glass and iron

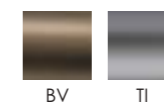

LA PALLINA

CONTROLLO DELL'INTENSITÀ LUMINOSA
CON INTERRUTTORE TOUCH

LIGHT INTENSITY CONTROL
WITH TOUCH SWITCH



Design Massimo Broglio
Registered Design





LA PALLINA

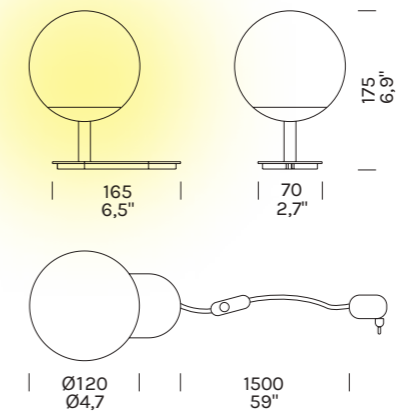

Alluminio e vetro soffiato a bocca
Aluminum and mouth-blown glass



NA

TEE

LAMPADA A BATTERIA
CON LUCE DIMMERABILE

RECHARGEABLE BATTERY LAMP
WITH DIMMABLE LIGHT



Design Marc Sadler
Registered Design





Batteria integrata
con autonomia
fino a 8 ore

Built-in battery
providing up to 8
hours of use



Pulsante nascosto
per regolazione
dell'intensità luminosa

Hidden button for light
dimming control



Base magnetica
posizionabile sotto alla
tovaglia per un design
più minimale

Magnetic base that can
be placed under the
tablecloth for a more
minimalist design

TEE

Ø120
Ø4,7



1,60
2,4"

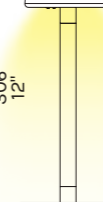

Alluminio, plexiglass
Aluminium, plexiglass



BO BV NO OR TI

INDOOR
LAMP
DA TERRA
FLOOR LAMPS

ASTRELLE PT

VETRO SOFFIATO A BOCCA
CON EFFETTO ALABASTRO

MOUTH-BLOWN GLASS WITH
ALABASTER FINISH



FIND OUT
ON OUR
WEBSITE



Design Marc Sadler

Registered Design





Vetro artigianale soffiato a bocca unito al metallo sfumato che sotto la luce si anima di riflessi iridescenti dal blu al viola.

Mouth-blown artisanal glass meets shaded metal that, when lit, comes alive with iridescent reflections, shifting from blue to purple.



ASTRELLE PT

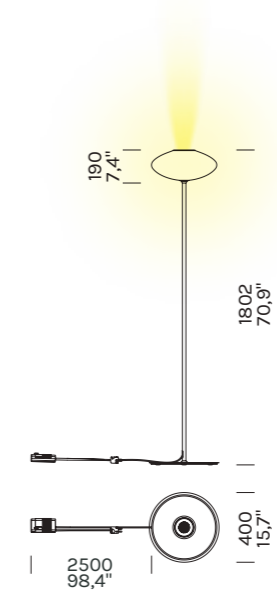

Ferro, alluminio, vetro soffiato a bocca
Iron, aluminum, mouth-blown glass

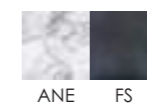

OVERFLY PT

RIPIANO IN LEGNO MASSICIO
DI NOCE CANALETTO

SOLID WOOD SHELF
IN CANALETTO WALNUT



Design Marc Sadler
Registered Design



290

OVERFLY PT

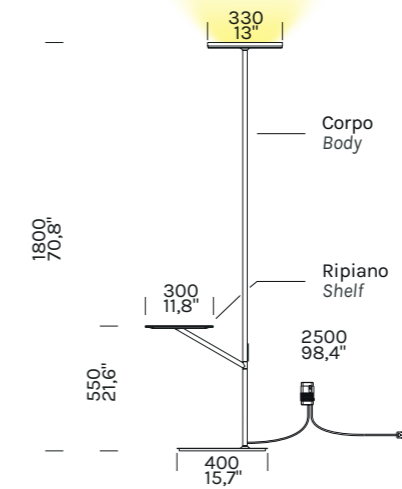

Ferro, alluminio, legno
Iron, aluminum, wood

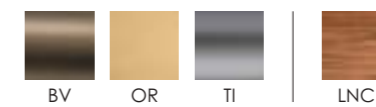

291

TRISEL PT

VETRO CANNETTATO
CHE FILTRA DOLCEMENTE LA LUCE

FLUTED GLASS
THAT SOFTLY FILTERS THE LIGHT



Design _blank design studio



Base in marmo Nero Marquinia levigato
Polished Nero Marquinia marble base

TRISEL PT

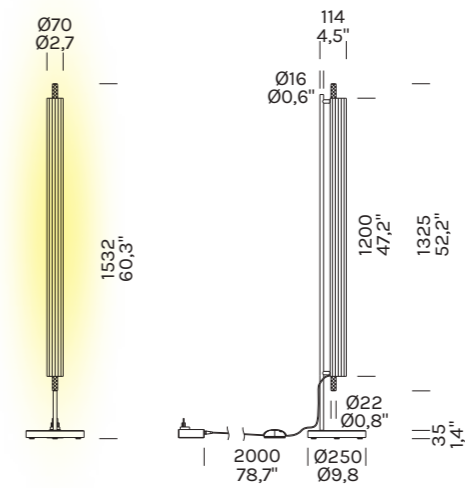

Alluminio, vetro borosilicato
Base in marmo Nero Marquinia levigato

Aluminum, borosilicate glass
Polished Nero Marquinia marble base

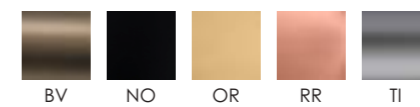

TERRA&LUNA PT

VETRO SOFFIATO A BOCCA
CON TEXTURE TRIDIMENSIONALE

MOUTH-BLOWN GLASS
WITH A THREE-DIMENSIONAL TEXTURE



FIND OUT
ON OUR
WEBSITE



Design Andrea Lanaro

Registered Design





TERRA&LUNA PT

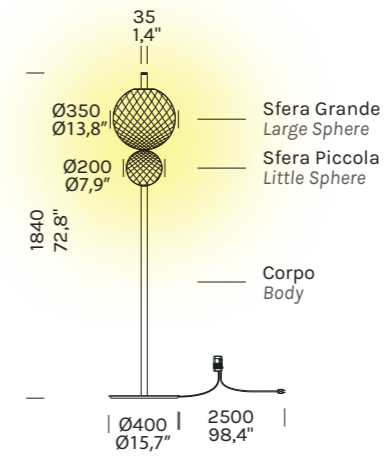

Alluminio e vetro soffiato a bocca
Aluminum and mouth-blown glass

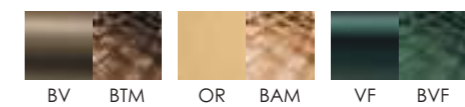

THIRTIES

DELICATE MICRO-INCISIONI A LASER
PER DIFFONDERE LA LUCE

DELICATE LASER MICRO-INCISIONS
TO DIFFUSE THE LIGHT

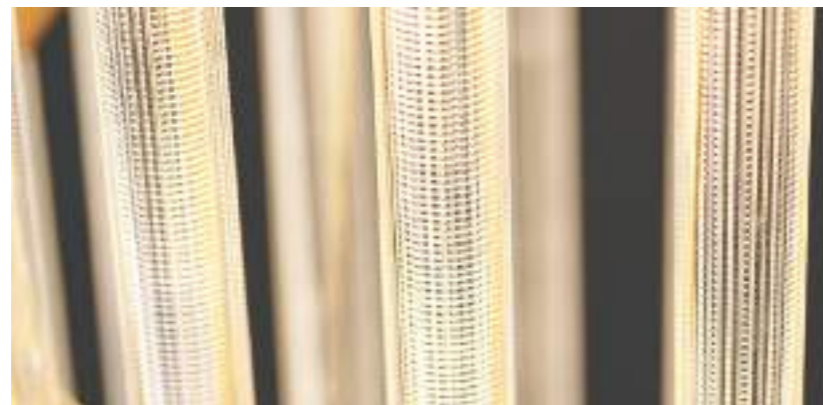

FIND OUT
ON OUR
WEBSITE



Design Elena Ogna

Registered Design





302

THIRTIES

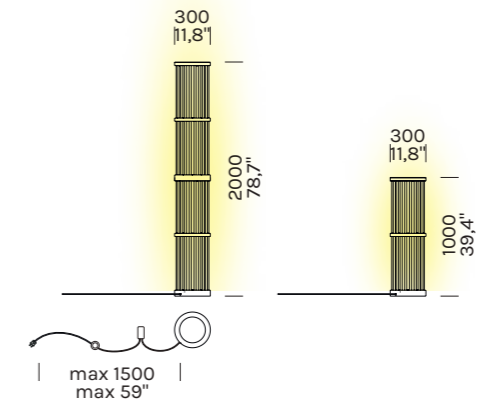

Alluminio, plexiglass
Aluminum, plexiglass



OR

303

BOOM

FASCIO DI LUCE ORIENTABILE A PIACERE

ADJUSTABLE LIGHT BEAM

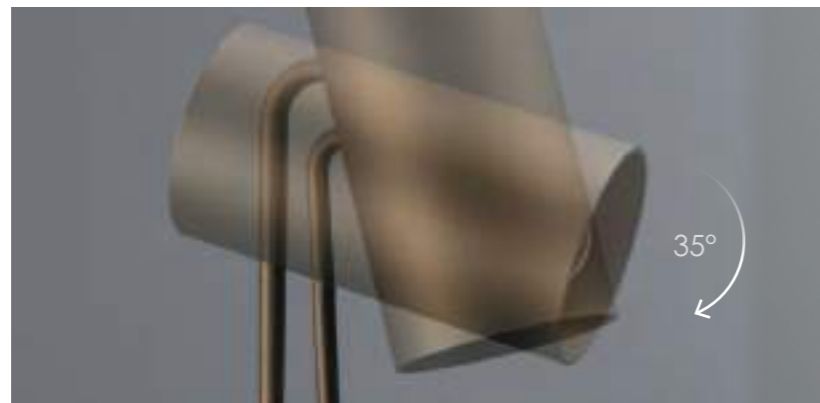

Design Marc Sadler
Registered Design





Base in marmo Nero Marquina levigato
Polished Nero Marquina marble base

BOOM

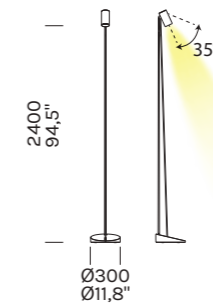

Carbonio, marmo, alluminio
Carbon, marble, aluminium

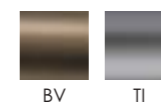

CRANE

LUCE VERSO L'ALTO E IL BASSO
CON SISTEMA DI DIMMERAZIONE TOUCH

UPWARDS AND DOWNWARDS LIGHT
WITH TOUCH DIMMING SYSTEM



Design OLEV Design Lab
Registered Design



Luce monodirezionale o bidirezionale verso il basso e verso l'alto, in contemporanea o singolarmente in base alla preferenza.

Floor lamp that offers a one or two-way downward and upward pointing light, simultaneously or individually based on the user's preference.

310

CRANE

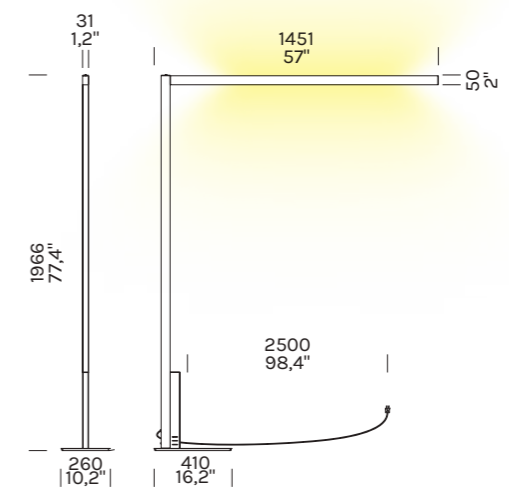

Alluminio
Aluminum



NA

311

SLIGHT PT



Design Massimo Tonetto



SLIGHT PT

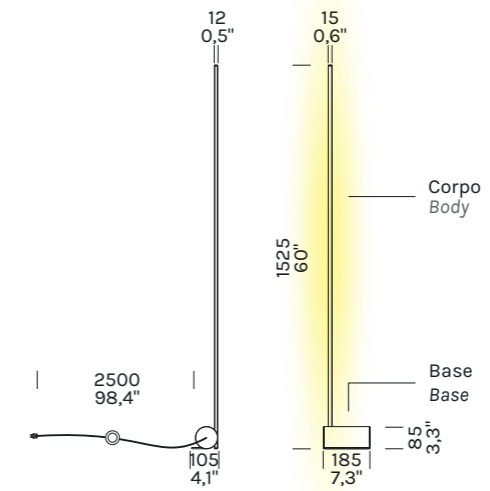

Alluminio e ferro
Aluminum and iron



NE

INDOOR

INDOOR
**LAMPADE DA
BINARIO**

TRACK LAMPS

BEAM MASTER TRACK 48V *Collection*

FASCIO DI LUCE ORIENTABILE
AMPIA GAMMA DI MISURE,
POTENZE E COLORAZIONI

ADJUSTABLE BEAM ANGLE
AVAILABLE IN A WIDE RANGE OF SIZES,
WATTAGES AND COLORS



FIND OUT
ON OUR
WEBSITE



Design Marc Sadler

Registered Design



BEAM MASTER MICRO TRACK 48V Ø25



Richiede binario micro track
Requires micro track

BEAM MASTER TRACK 48V Ø35

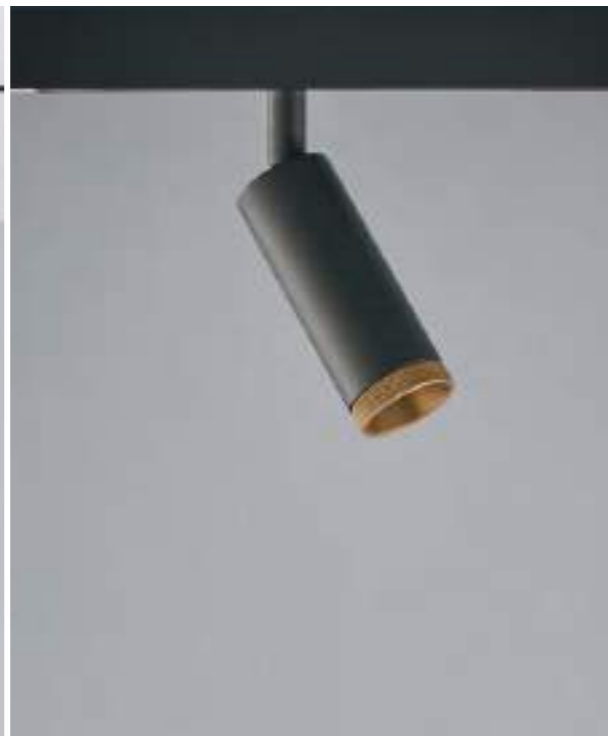

BEAM MASTER TRACK 48V Ø60



BEAM MASTER TRACK 48V Ø80



BEAM MASTER MICRO TRACK 48V Ø25

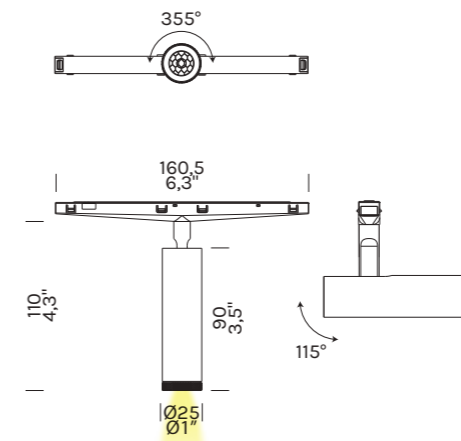

BEAM MASTER TRACK 48V Ø60

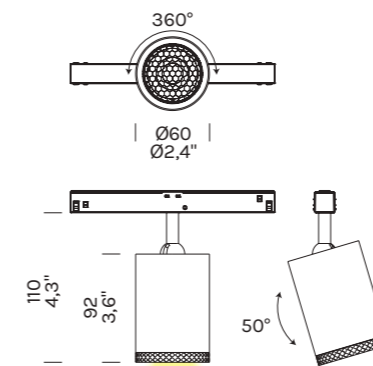

BEAM MASTER TRACK 48V Ø35

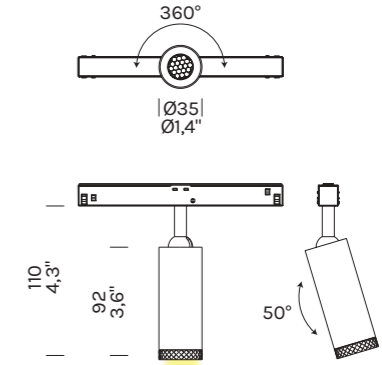

BEAM MASTER TRACK 48V Ø80

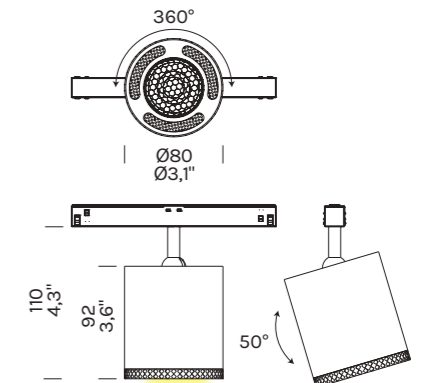

Alluminio
Aluminum



BEAM MASTER TRACK 48V Ø60 ZUMMY



BEAM MASTER TRACK 48V Ø60 ZUMMY

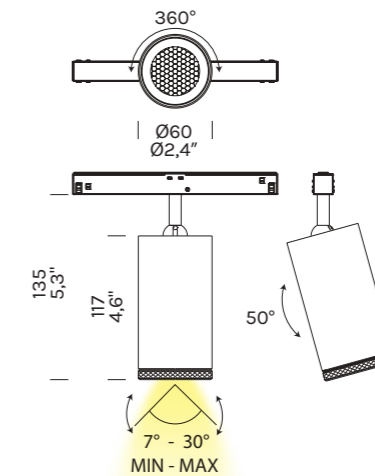

Faretto orientabile con fascio di luce regolabile.
Ruotando la ghiera è possibile infatti mantenere costante la larghezza del fascio luminoso anche se la lampada è posta a diverse altezze di soffitto.

Adjustable spotlight with adjustable light beam.
By turning the ring it's possible to keep the width of the light beam constant even if the lamp is placed at different ceiling heights.

Alluminio
Aluminum

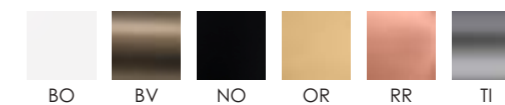

EYE SPOT TRACK 48V



Design Filippo Cannata
Registered Design

FIND OUT
ON OUR
WEBSITE

EYE SPOT MICRO TRACK 48V

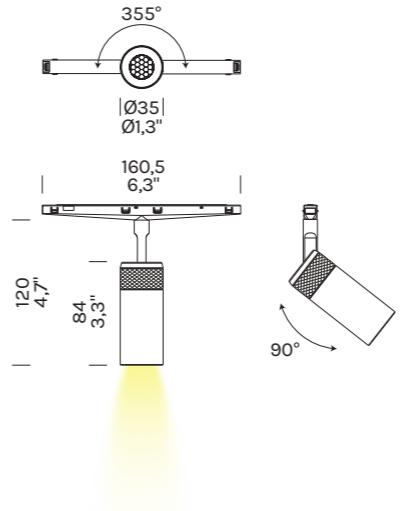

EYE SPOT TRACK 48V

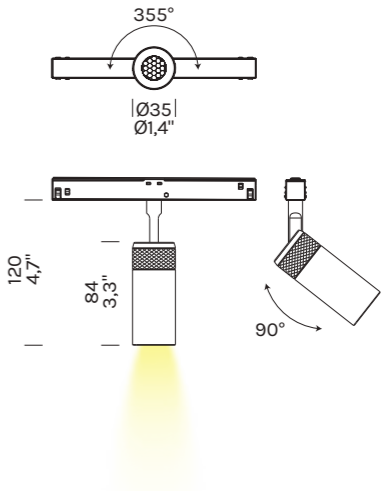

Alluminio
Aluminum



OVERFLY TRACK 48V

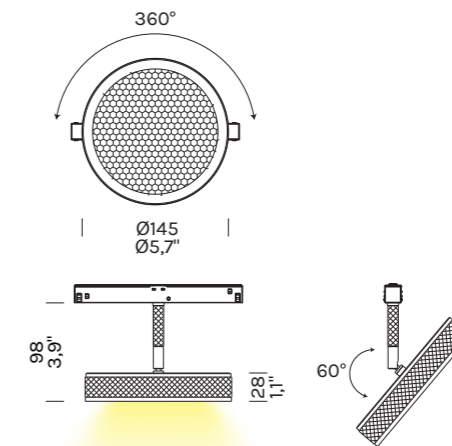

Alluminio, plexiglass
Aluminium, plexiglass



Design Marc Sadler
Registered Design

SHINE SPOT TRACK 48V



Design OLEV Design Lab



SHINE SPOT TRACK 48V

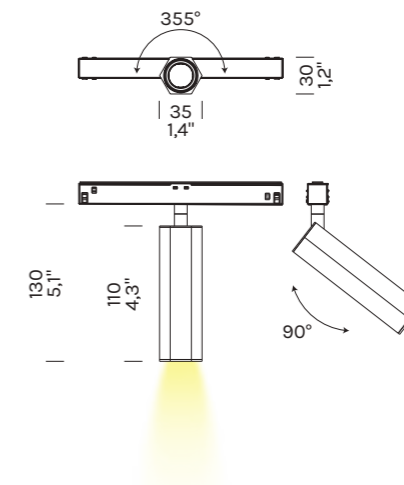

Ottone
Brass



BEAM MASTER TRACK 230V



Design Marc Sadler
Registered Design

BEAM MASTER TRACK 230V Ø60

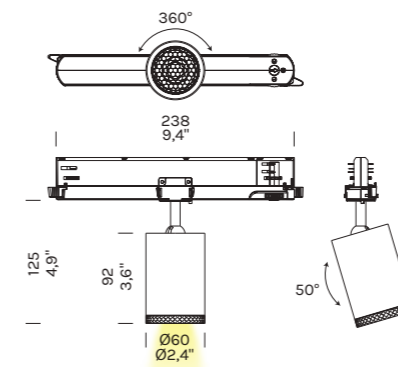

BEAM MASTER TRACK 230V Ø80

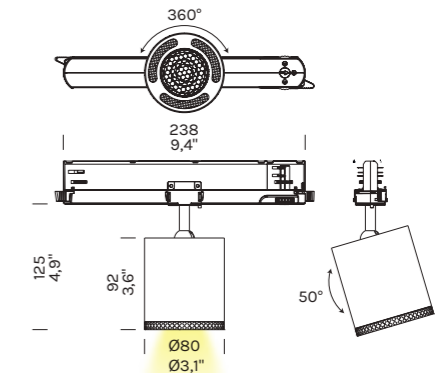

Alluminio
Aluminum



OUTDOOR
DESIGN
ROOM

OUTDOOR
**LAMPADE DA
PARETE**

WALL LAMPS

MARKIL



Design Marc Sadler
Registered Design



MARKIL

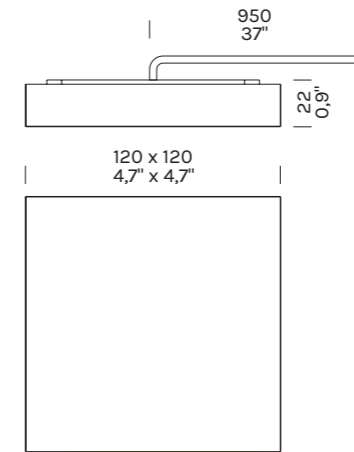

Alluminio
Aluminum



UP&DOWN



Design OLEV Design Lab

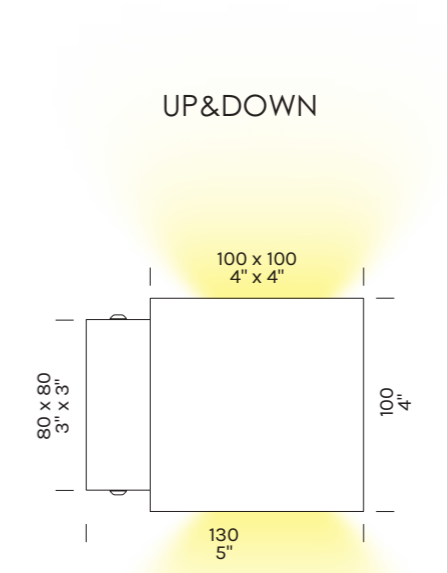

Alluminio
Aluminum

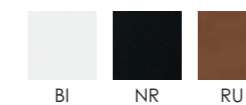

OUT

D

OR

OUTDOOR

**LAMPADE DA
SOFFITTO INCASSO**

RECESSED
CEILING LAMPS

MINI DOT DOWN LIGHT



Design Filippo Cannata

340

MINI DOT DOWN LIGHT

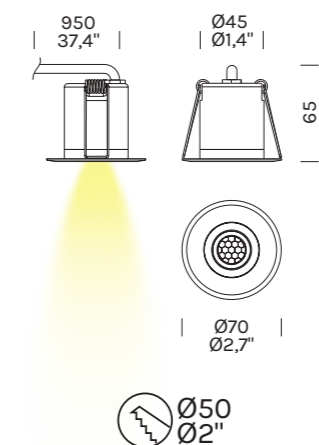

Alluminio, inox 316
e vetro

Aluminum, stainless steel 316
and glass



Al

341

MAXI DOT DOWN LIGHT



Design Filippo Cannata
Registered Design

342

MAXI DOT DOWN LIGHT

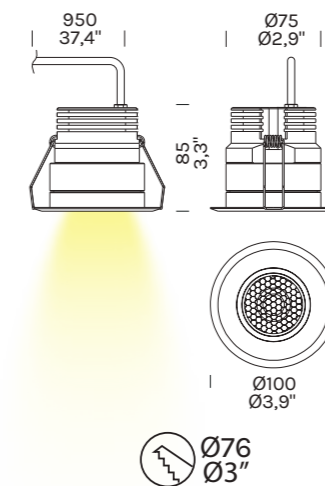

Alluminio, inox 316
e vetro

Aluminum, stainless steel 316
and glass

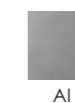

343

OUTDOOR
DESIGN
ROOMS

OUTDOOR
**LAMPADE
DA TERRA**

FLOOR LAMPS

PEPITO

PICCOLE ED ELEGANTI
PIETRE PREZIOSE
CHE ILLUMINANO IL VIALE

LITTLE, ELEGANT
PRECIOUS GEMSTONES
THAT LIGHT UP THE WAY



Design Lo Studio Mammini Candido





PEPITO

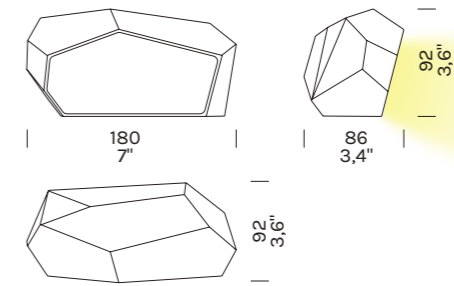

Alluminio, plexiglass
Aluminum, plexiglass

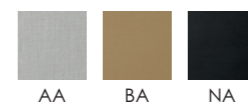

ZOELLA

SI MIMETIZZANO NELLA VEGETAZIONE
COME PICCOLE FOGLIE

THEY BLEND INTO THE VEGETATION
LIKE SMALL LEAVES



Design Lo Studio Mammini Candido

Registered Design



FIND OUT
ON OUR
WEBSITE





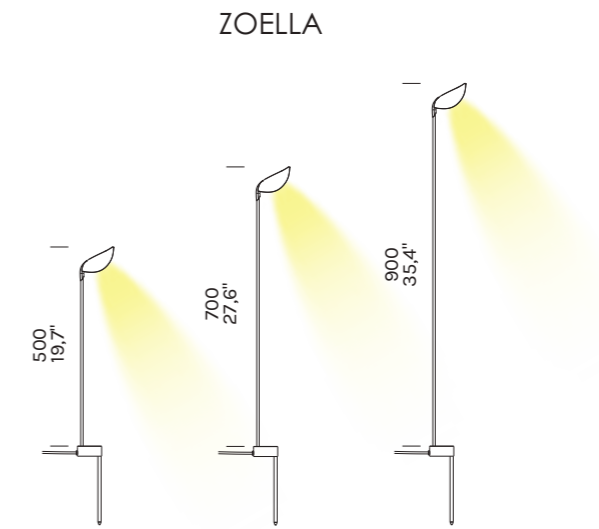

Alluminio
Aluminum

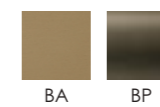

SPREAD



Design OLEV Design Lab

Registered Design





SPREAD

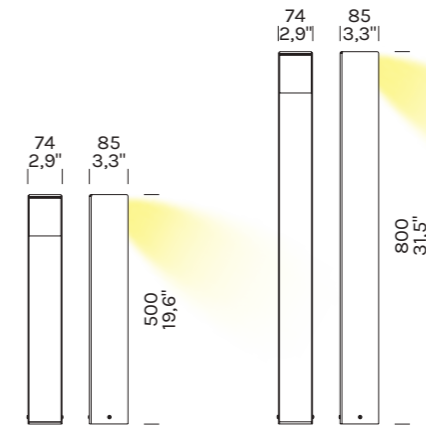

Acciaio inox
Stainless steel

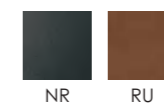

TORCH



Design OLEV Design Lab





362

TORCH

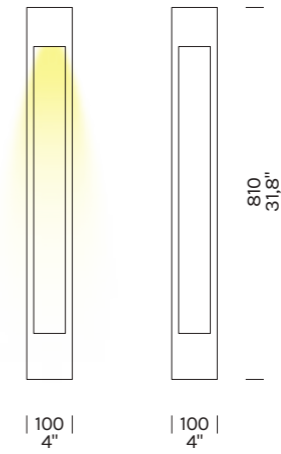

Acciaio inox
Stainless steel

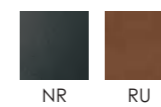

363

GROUNDING



Design Harry Thaler
Registered Design

364



GROUNDING

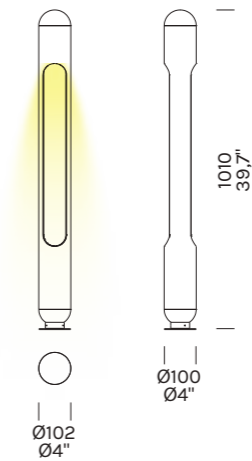

Acciaio inox
Stainless steel

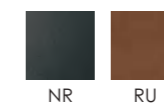

365

CEMENTO

DIFFONDE LUCE E SUONO
CON DETTAGLI ELEVATI DELL'AUDIO
ANCHE A BASSO VOLUME

SPREADS LIGHT AND SOUND
WITH HIGH AUDIO DETAILS
EVEN AT LOW VOLUMES



Design Roberto Lanaro e Luca Toniolo

Registered Design



368

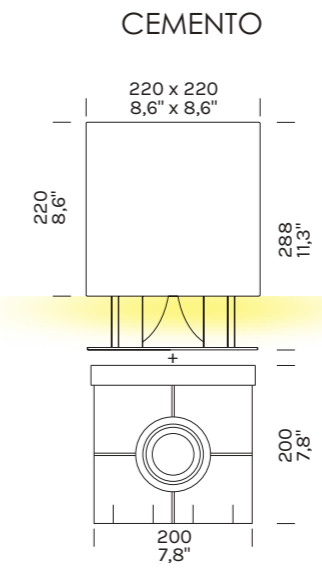

Acciaio inox 316, cemento
Stainless steel 316, concrete

369

STEP LINE



370

STEP LINE

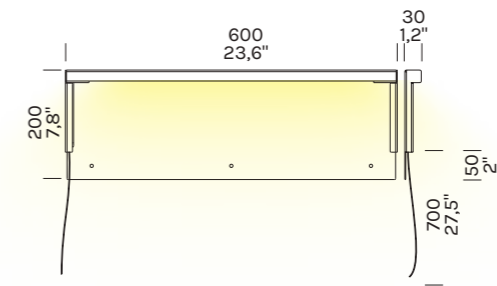

Acciaio inox
Stainless steel

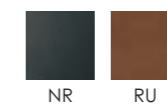

371

MAXI DOT SPOT



Design Filippo Cannata
Registered Design



MAXI DOT SPOT

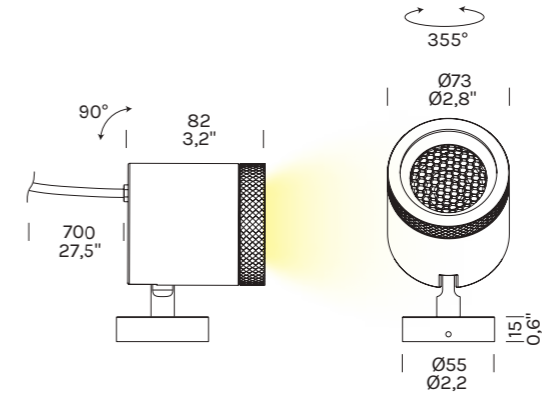

Alluminio e vetro
Aluminum and glass

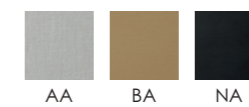

MINI DOT SPOT



Design Filippo Cannata
Registered Design



MINI DOT SPOT

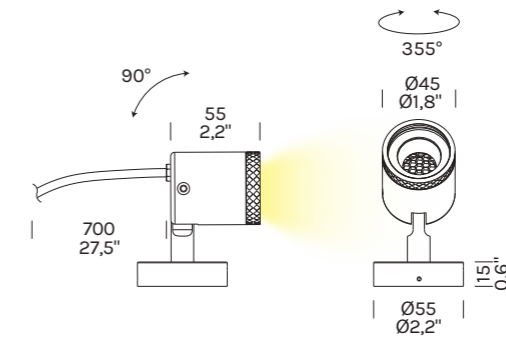

Alluminio e vetro
Aluminum and glass

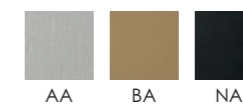

OUTDOOR
RECESSED
FLOOR LAMPS

OUTDOOR
**LAMPADE DA
TERRA INCASSO**

**RECESSED
FLOOR LAMPS**

MAXI DOT UP LIGHT



Design Filippo Cannata



MAXI DOT UP LIGHT

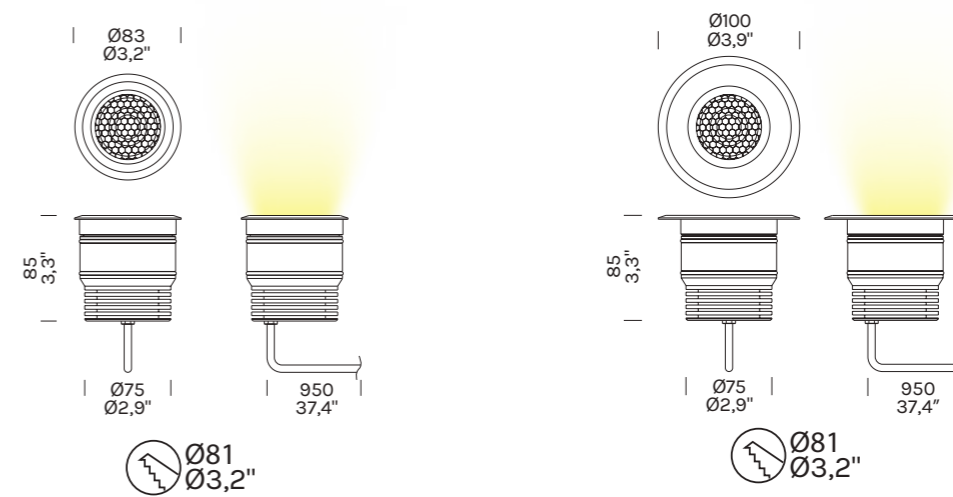

Alluminio, acciaio inox 316 e vetro
Aluminum, stainless steel 316 and glass



MINI DOT UP LIGHT



Design Filippo Cannata



MINI DOT UP LIGHT

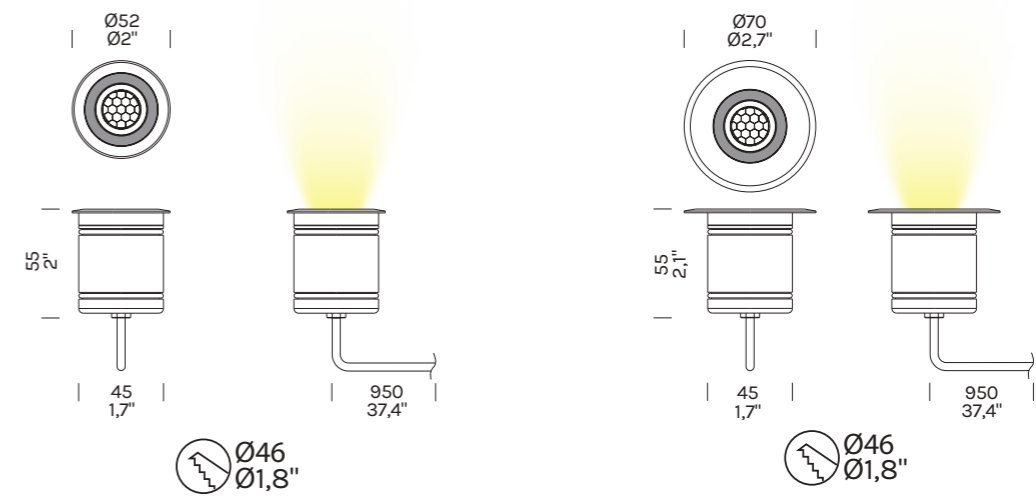

Alluminio, acciaio inox 316 e vetro
Aluminum, stainless steel 316 and glass

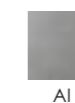

MINI DOT GLASS UP LIGHT



Design Filippo Cannata

FIND OUT
ON OUR
WEBSITE

MINI DOT GLASS UP LIGHT

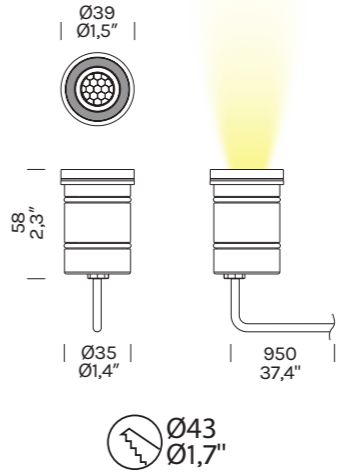

Alluminio e vetro
Aluminum and glass

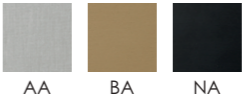



OLEV S.r.l.
via del Progresso, 40
36064 Colceresa (VI)
ITALY
T +39 0424 411 403
info@olevlight.com
olevlight.com

Si ricorda che il documento di riferimento per tutte le dimensioni dettagliate, finiture e dati tecnici è il Listino che viene periodicamente aggiornato.

I disegni, le quote, i materiali ed i colori ivi riportati si intendono a titolo indicativo. Nell'interesse della clientela, OLEV si riserva il diritto di apportare modifiche in ogni momento senza l'obbligo di preavviso. È vietata la riproduzione, anche parziale, di questo documento.

Dove non diversamente indicato, le quote sono da intendersi in millimetri

Please note that all detailed dimensions, finishes and technical data can be found in the Price List which is periodically updated.

The drawings, dimensions, materials and colours in this book are for informational purposes only. In the interest of its customers, OLEV reserves the right to make changes at any time without prior warning. Reproduction, even partial, of this book is prohibited.

Unless otherwise indicated, dimensions are in millimetres.





OLEVLIGHT.COM