

For MDF Italia, design is about shaping matter with ideas—anchored in the belief that there can be no project without prior thought and there are no thoughts without contamination from different perspectives. More than simple products, the results of this process are thought forms, consistently reimagined as products and spaces that reflect the brand's values: simplicity, lightness, and wonder.

book 1 Indoor

book 2 Outdoor

book 3 Contract

book 4 News 24

book 5 News 25

mdf italia

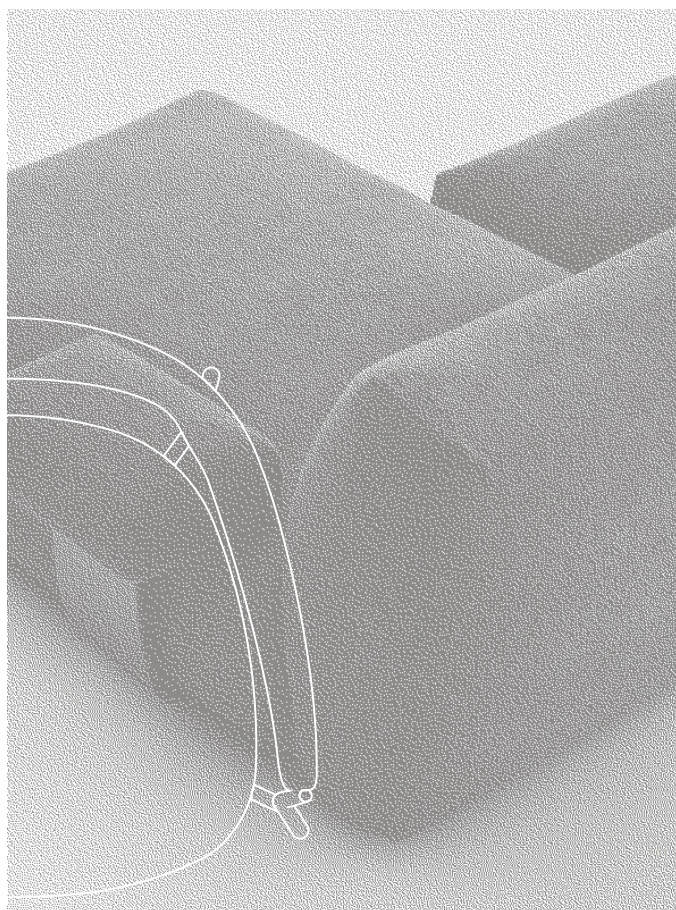
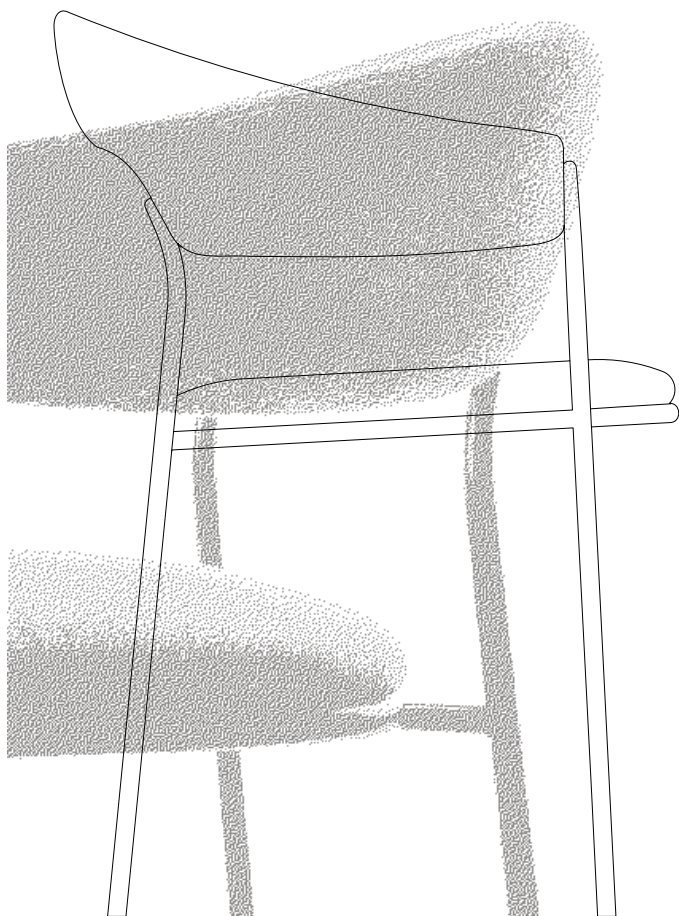

News book

2025

News book Index

Introduction	2
Products collection	4
An icon, according to MDF Italia	6
Timeless, Iconic, Random	8
A contemporary retreat	10
An intimate, essential space	46
Technicals	62

Sofas
and armchairs

Cantle	
Cosy Outdoor	
Goom ^{NEW!}	16
Neil Leather collection ^{NEW!}	24
Neil Twist	
Tables and coffee tables	
Array low table	
Bonnet	
Cantle low table ^{NEW!}	28
S Table ^{UPDATE}	44

Systems
and bookcases

Link 1	
Minima 3.0	
Pentagramma	
Random collection ^{UPDATE}	40
Chairs	
Archie ^{NEW!}	38
Neil Twist	

News book

2025

mdf italia

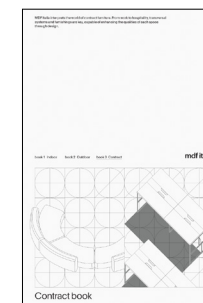
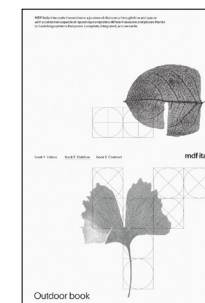

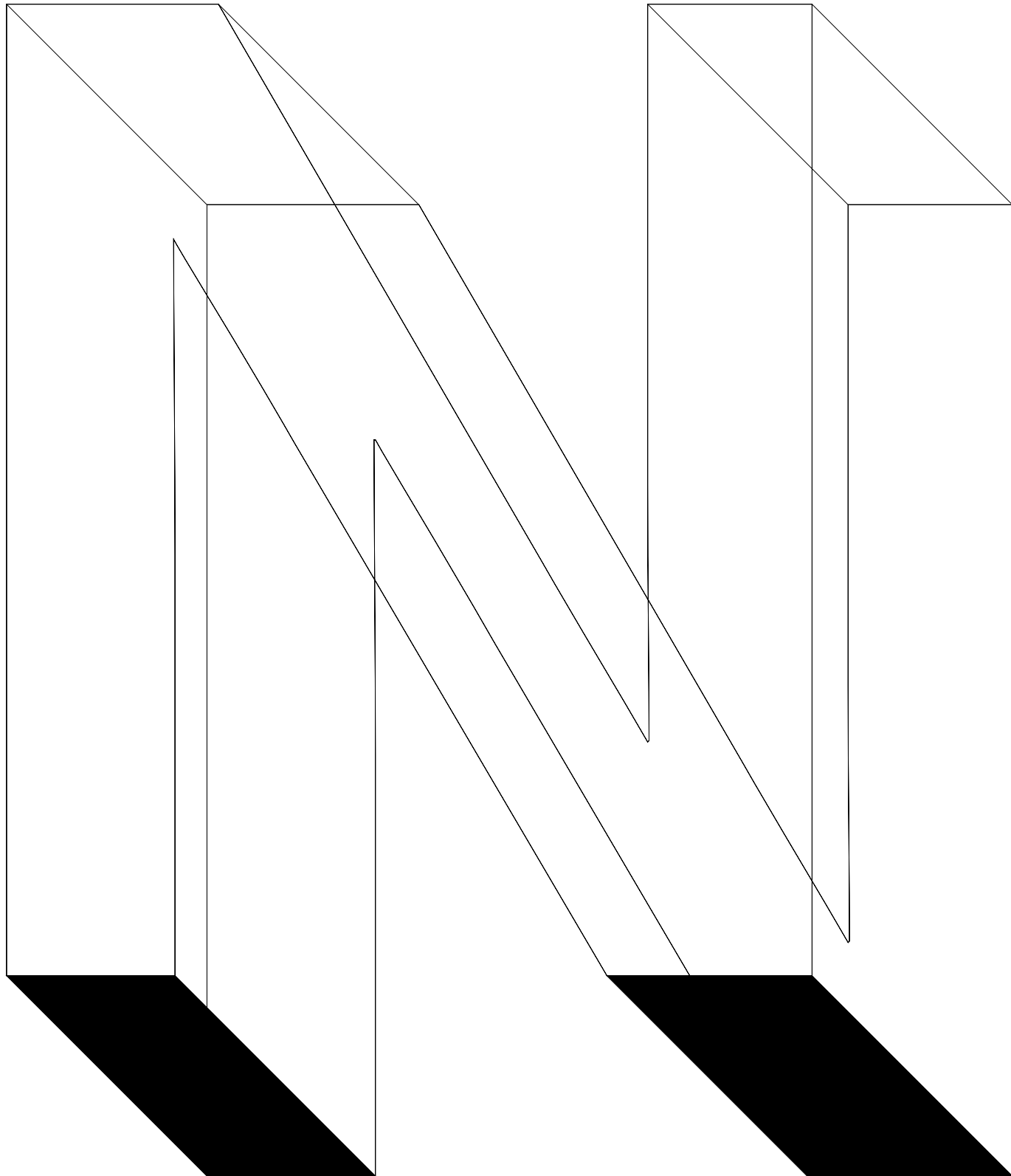

EN MDF Italia designs and produces furniture and objects that aspire to excellence, characterised by essential forms and a constant drive for innovation. Its 2025 vision unfolds in two directions. The first focuses on upholstered furniture, with Jean Marie Massaud exploring the idea of wonder through all-encompassing comfort. The second is the result of a collaboration with Yabu Pushelberg—one of the most compelling architecture studios on today's scene—showcasing the brand's design ethos.

IT MDF Italia pensa e produce arredi e oggetti di design che aspirano all'eccellenza, caratterizzati dalla sfida progettuale e dall'essenzialità delle forme, pensati per rendere unico ogni luogo domestico. Una visione che per il 2025 evolve in due direzioni. La prima è quella degli imbottiti, in cui, insieme a Jean Marie Massaud, si ricerca la meraviglia attraverso un comfort avvolgente. La seconda sancisce, nella collaborazione con Yabu Pushelberg, uno dei più interessanti studi di architettura della scena contemporanea, l'attitudine progettuale dell'azienda.

Sofas and armchairs



Cantle armchair



Cosy Outdoor

Systems and bookcases



Goom



Neil Leather collection



Pentagramma

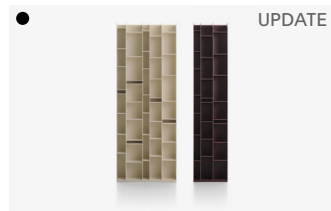

Random collection



Minima 3.0



Link 1

Tables and coffee tables



Array coffee table



Bonnet



Cantle low table



S Table

Chairs



Archie



Neil Twist collection

EN A distinctive shape, a clear function, and an expressive power capable of capturing the imagination. A design icon is more than a well-designed object: it's an archetype—cited, reinterpreted, and instantly recognizable through a single defining detail. Since its inception, MDF Italia has aimed to create objects with the potential to become iconic. Over the years, some of its pieces have succeeded, becoming part of the canon of contemporary design.

IT Una forma peculiare, una funzione chiara e una forza espressiva capace di segnare l'immaginario. Un'icona del design è molto più di un oggetto ben progettato: è un archetipo destinato a essere citato, reinterpretato, immediatamente riconosciuto a partire da un dettaglio. Se da sempre la vocazione di MDF Italia è creare oggetti che abbiano la capacità di diventare icone, nel corso degli anni alcuni pezzi sono riusciti nell'impresa di entrare nel canone del design contemporaneo.



An icon, according to MDF Italia



Timeless

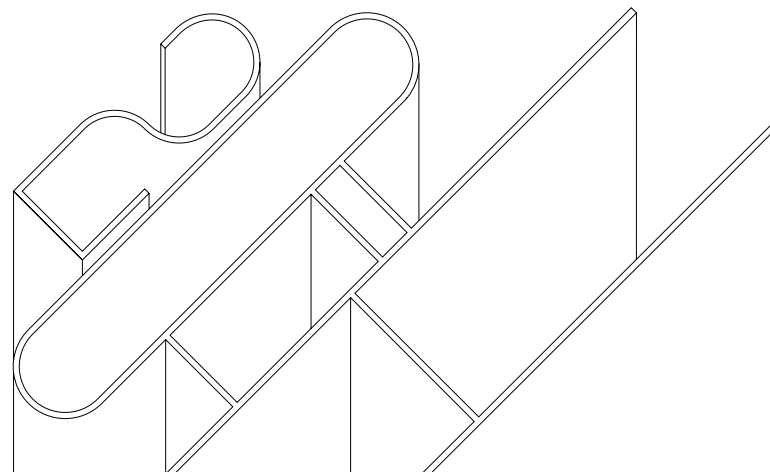

EN A true icon of the MDF Italia collection, Random celebrates its 20th anniversary in 2025. Designed in 2005 by Neuland Industriedesign, its distinctive lines redefined the very concept of the bookshelf, transforming a functional container into a sculptural design piece. Random was the first bookcase to display objects rather than conceal them, marking a true paradigm shift. A long-standing MDF Italia best-seller, it has been continuously updated over the years and was selected in 2006 for the XXI Compasso d'Oro ADI.

IT Un'icona della collezione MDF Italia è Random, che nel 2025 compie vent'anni. Progettata nel 2005 dallo studio Neuland Industriedesign, con le sue linee ha rivoluzionato il modo di intendere la libreria, trasformando un contenitore funzionale in una scultura di design. Random fu la prima libreria che mostrò gli oggetti anziché nasconderli, segnando così un cambio di paradigma. Bestseller di MDF Italia, in continua evoluzione e aggiornamento, nel 2006 è stata selezionata per il XXI Compasso d'Oro ADI.

Iconic Random





EN A villa immersed in nature blends contemporary architectural lines with a soft, warm aesthetic. Different shades of white, enriched by the warmth of wood accents, create a welcoming atmosphere—a domestic retreat where time slows down and space feels effortlessly livable.

IT Una villa immersa nella natura unisce suggestioni architettoniche contemporanee a un'estetica morbida e calda. Le diverse tonalità di bianco, accese dal tocco caldo del legno, creano ambienti accoglienti, dando vita a un rifugio domestico in cui il tempo è sospeso e lo spazio piacevole da vivere.

A contemporary retreat

Concept house
Architecture

N.1
Pitsou Kedem

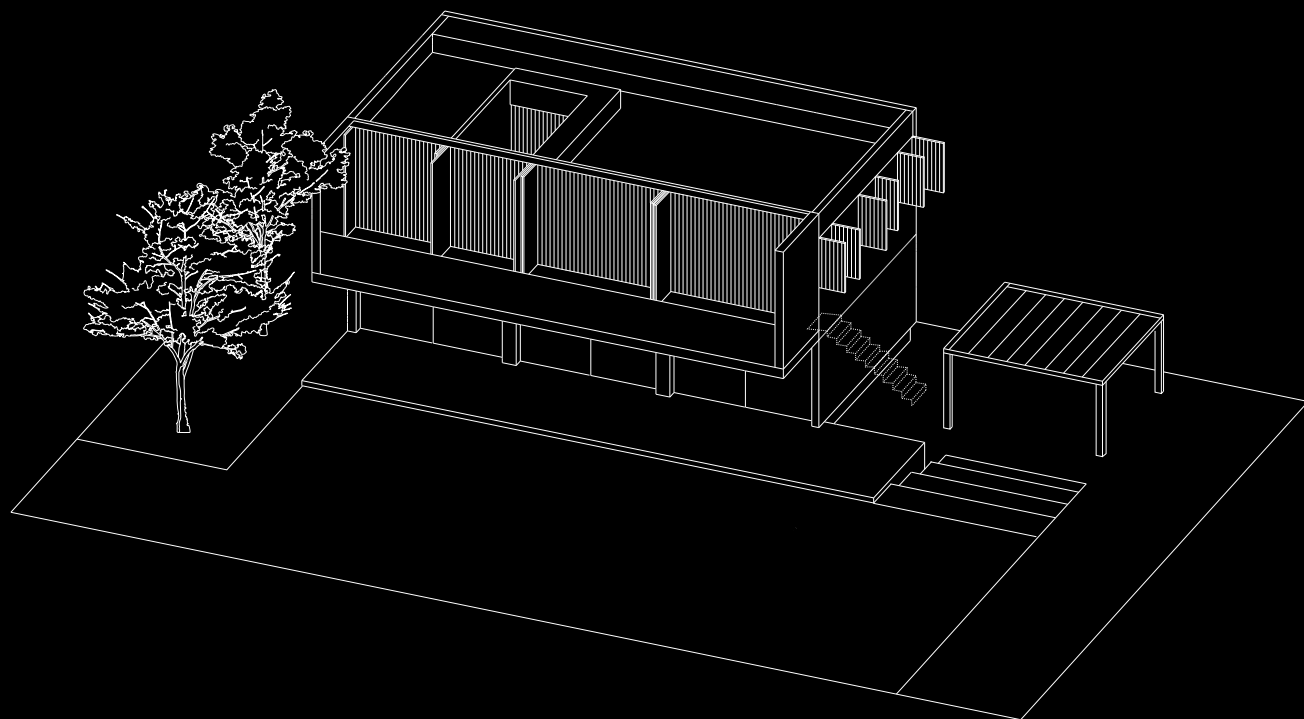



NEW!

Neil Leather collection



NEW!

Goom



Array coffee table

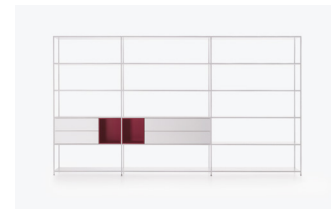

Minima 3.0

→ Goom is a modular system comprising a single unit, a chaise longue, two corner units and two poufs, with the option of adding one or more armrests.

All elements are designed to allow for personalised configurations.



Goom



Minima 3.0





EN A soft, enveloping sofa where sharp, concise lines highlight full, generous volumes. Designed by Jean Marie Massaud, Goom is a modular system conceived to adapt to different configurations, combining single elements with corner modules, chaise longues, and poufs. Comfort is its true design value, the result of in-depth research into materials aimed at achieving maximum softness. A tribute to the force of gravity, Goom is a sculptural volume designed for total immersion in comfort. From the wooden internal structure to the upholstery and foams, Goom has been designed to be fully disassembled, embracing a circular economy approach.

IT Un divano morbido e avvolgente, in cui linee nette e concise enfatizzano volumi pieni e generosi. Progettato da Jean Marie Massaud, Goom è un sistema modulare pensato per adattarsi a diverse configurazioni, combinando l'elemento singolo con moduli angolari, chaise longue e pouf. Il comfort è il vero valore progettuale, risultato di una ricerca approfondita sui materiali e sulla massima morbidezza. Elogio alla forza di gravità, Goom è un solido in cui sprofondare con gusto. Dalla struttura interna in legno ai rivestimenti, dall'imbottitura realizzata con gomme a densità differenziata, Goom è stato progettato per poter essere completamente disassemblato, in un'ottica di economia circolare.

Goom

Sofa system

Designed by Jean Marie Massaud



Single unit	L103 D118 H76	A
Chaise longue unit	L103 D173 H76	B
90° corner unit	L134 D134 H76	C
120° corner unit	L143 D134 H76	D
Square pouf unit	L103 D103 H42	E
Rectangular pouf unit	L103 D73 H42	F
Armrest for single unit and chaise longue	L30 D45	G

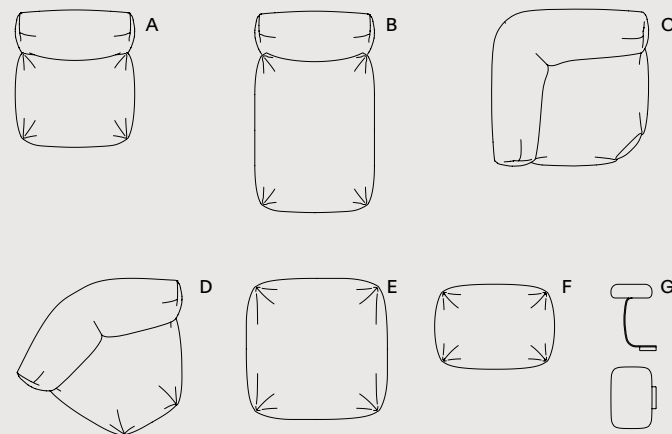



Goom

Sofa system

Designed by Jean Marie Massaud





Link 1



Neil Leather collection



Goom



Cantle low table



Minima 3.0



← Available in five shades, the leather is entirely handcrafted: heavy-duty thread stitching, tone-on-tone dyed edges and embossed pressed detailing contribute to a precise and sophisticated aesthetic.

A handcrafted piece, 100% made in Italy, it combines formal rigour with meticulous attention to detail – ideal for contemporary interiors with a refined and discerning character.



Neil Leather collection



EN Neil by Jean Marie Massaud is a constantly evolving seating collection, distinguished by its simplicity, versatility, and design precision. Its defining element is the steel rod structure, which outlines a minimalist architectural frame. The leather upholstery brings refined character to the armchair, turning it into an elegant complement for both home living areas and contemporary lounges.

IT Neil di Jean Marie Massaud è un progetto in continua evoluzione, una collezione di sedute riconoscibili per la loro essenzialità, versatilità e precisione progettuale. Filo conduttore è la struttura in filo d'acciaio, che disegna un'architettura semplice e leggera, mentre il rivestimento in cuoio conferisce alla seduta una personalità sofisticata, trasformandola in una poltrona essenziale ed elegante, perfetta come complemento del living domestico e delle lounge contemporanee.

Neil Leather

Armchair

Designed by Jean Marie Massaud



Armchair

L78 D65 H71
seat H40

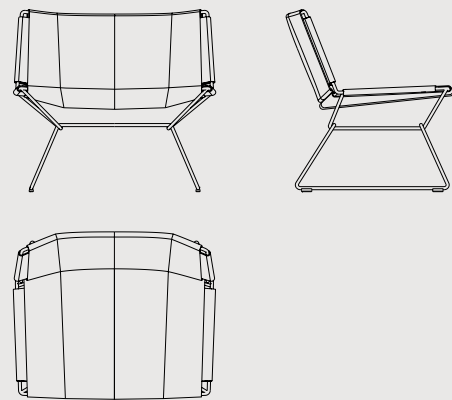

→ Perfect as a standalone piece, Cantle low table also lends itself to modular combinations, giving

rise to dynamic and versatile compositions suited to both domestic interiors and contract spaces.



Cantle low table



Goom



Minima 3.0





EN The Cantle collection by Marco Lavit expands with a family of coffee tables characterised by the iconic V-shaped bracket. This graphic element, a signature of the entire collection, creates a suspended effect. Available in three sizes and various finishes—including Canaletto Walnut, Black Ash, Bleached Oak, and glossy lacquer—the tables are ideal alongside armchairs and sofas or as standalone pieces.

IT La collezione Cantle, firmata da Marco Lavit, si amplia con una famiglia di tavolini caratterizzata dall'iconico elemento della staffa a V. Trait d'union di tutta la collezione, la V crea in questo caso un particolare effetto di sospensione. Disponibili in tre dimensioni e diverse finiture, i tavolini possono essere usati sia per affiancare poltrone e divani sia come coffee table.

Cantle

Low table

Designed by Marco Lavit

Wood top

Bleached oak X075	Canaletto walnut X159	Black stained ash X083
----------------------	--------------------------	---------------------------

Matt painted frame

Graphite grey X054

Gloss lacquered top

Black X174	Burgundy X211	English green X176
---------------	------------------	-----------------------

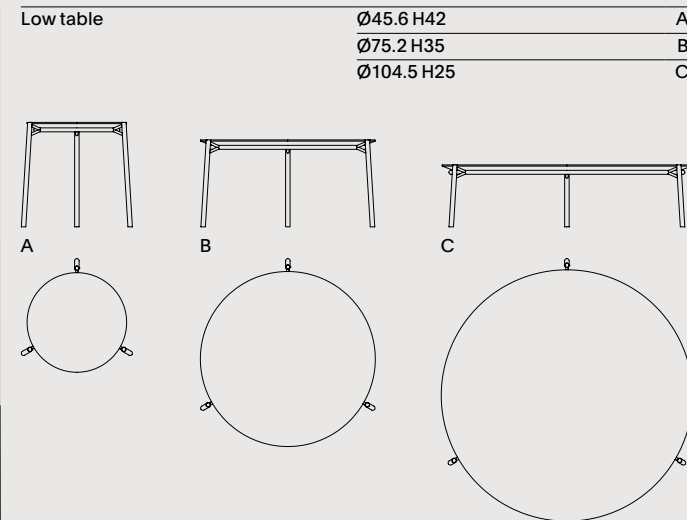

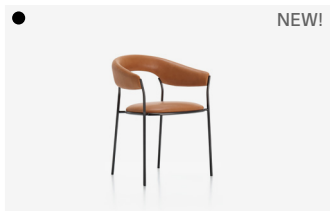

Archie

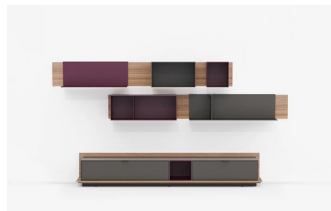

Pentagramma



Bonnet





← With Archie, the studio pushes MDF Italia's legacy of technical innovation even further, creating

a sleek, minimalist structure that blends Italian heritage with the studio's inventive spirit.



NEW!

Archie



UPDATE

S Table

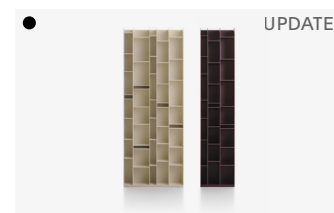

UPDATE

Random collection



EN Inspired by the geometric shape of the arch, Archie features slender, elegant legs that extend upwards to embrace the curved backrest in a single, seamless line. Designed by Yabu Pushelberg, the piece features a sculptural presence, with backrest and armrest fused into one continuous, flowing form. It is designed to be fully removable and disassembled, and the visible joints between the structure's planes underscore a meticulous process of refinement, balancing visual lightness, structural integrity, and comfort.

IT Ispirata alla forma dell'arco, la sedia Archie è caratterizzata da gambe sottili ed eleganti, che si estendono verso l'alto per abbracciare lo schienale curvo in un unico segno. Lo studio Yabu Pushelberg, autore del progetto, ne sottolinea l'aspetto scultoreo, con schienale e bracciolo fusi in una forma unica e fluida. Nella sedia, che può essere sfoderata e completamente disassemblata, le giunzioni fra i diversi piani della struttura restano visibili, come indizi di un sapiente lavoro di sottrazione e compromesso tra leggerezza visiva, integrità strutturale e comfort.

Archie

Chair

Designed by Yabu Pushelberg

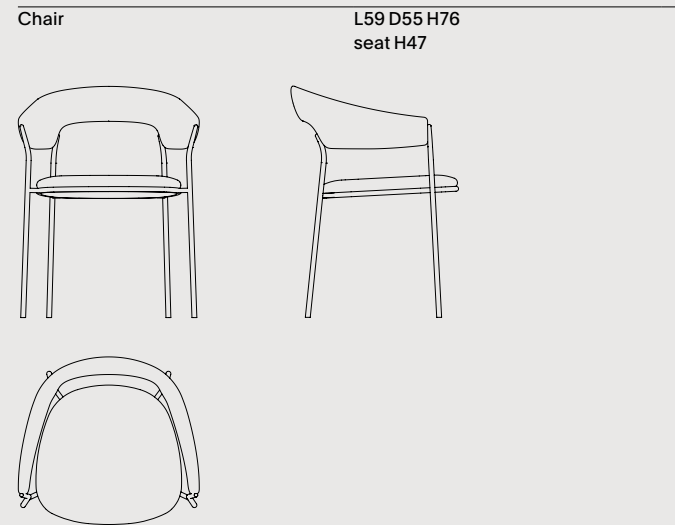



Archie

Chair

Designed by Yabu Pushelberg



EN “Our partnership with MDF Italia came naturally; they are sharp, design-savvy, and refreshingly youthful. When we began working together, we set out to create something refined, something attuned to how people live, move, and engage with objects today. MDF Italia gave us the freedom to explore that vision, while honouring the enduring DNA of Italian product design.”

IT “La nostra collaborazione con MDF Italia è nata in modo naturale: un partner attento, consapevole e con uno sguardo giovane sul progetto. Quando abbiamo iniziato a lavorare insieme, ci siamo posti l’obiettivo di creare qualcosa di raffinato, in sintonia con il modo in cui oggi le persone vivono, si muovono e interagiscono con gli oggetti. MDF Italia ci ha dato la libertà di esplorare questa visione, rispettando al tempo stesso il DNA senza tempo del design italiano.”

Yabu Pushelberg

Studio

EN Yabu Pushelberg designs places and products: immersive environments, compelling destinations, and considered goods. George Yabu and Glenn Pushelberg founded the studio in 1980 with an emphasis on interior design and have since expanded the studio into a multidisciplinary practice that addresses multiple layers of human experience. With offices in New York and Toronto and a team of more than a hundred creatives and professionals, the studio specialises in sensibilities spanning buildings, interiors, landscapes, lighting, furniture, objects, and graphics with a focus that goes well beyond what things look like, to how they make people feel.

IT Yabu Pushelberg progetta luoghi e prodotti: ambienti immersivi, destinazioni affascinanti e prodotti realizzati con cura. Fondato nel 1980 da George Yabu e Glenn Pushelberg con un focus iniziale sul design d’interni, lo studio si è evoluto in una realtà multidisciplinare che esplora le molteplici sfaccettature dell’esperienza umana. Con sedi a New York e Toronto, e un team di oltre cento creativi e professionisti, lo studio si distingue per un approccio sensibile che abbraccia architettura, interior design, paesaggio, illuminazione, arredi, oggetti e grafica. Il loro lavoro va oltre l’estetica, ponendo al centro di ogni progetto il modo in cui gli spazi e gli oggetti fanno sentire le persone.





EN A timeless icon in the MDF Italia collection, Random defines space through its irregular arrangement of shelves, just 6 mm thick. Varying in height, they hold not only books, but also personal objects that reflect each individual's story and identity. Over the years, Random has evolved through versions like 2C, 3C, 5C, and Randomito, becoming a system that offers broad compositional freedom—capable of generating virtually infinite configurations, always marked by a sense of lightness. The new colours—English green, burgundy red, and ivory white—expand the existing range, making the collection even more contemporary and versatile.

IT Icona senza tempo della collezione MDF Italia, Random ritma lo spazio grazie alla struttura irregolare dei ripiani di soli 6 mm di spessore. Giocati su diverse altezze, ospitano non solo libri, ma anche oggetti che raccontano la storia e la personalità di ogni individuo. Negli anni Random si è evoluta con le versioni 2C, 3C, 5C e Randomito, trasformandosi in un sistema che offre un'ampia libertà compositiva, con cui dare vita a configurazioni pressoché infinite, sempre caratterizzate da grande leggerezza. Le nuove tinte – verde inglese, rosso burgundi e bianco avorio – ampliano la palette colori, rendendo la collezione ancora più attuale e versatile.

Random

Collection

UPDATE

Designed by Neuland Industriedesign

2C	L35.8 D25 H217	A
3C	L46.4 D25 H217	B
5C	L81.6 D25 H217	C
Randomito	L81.6 P20 H96	D

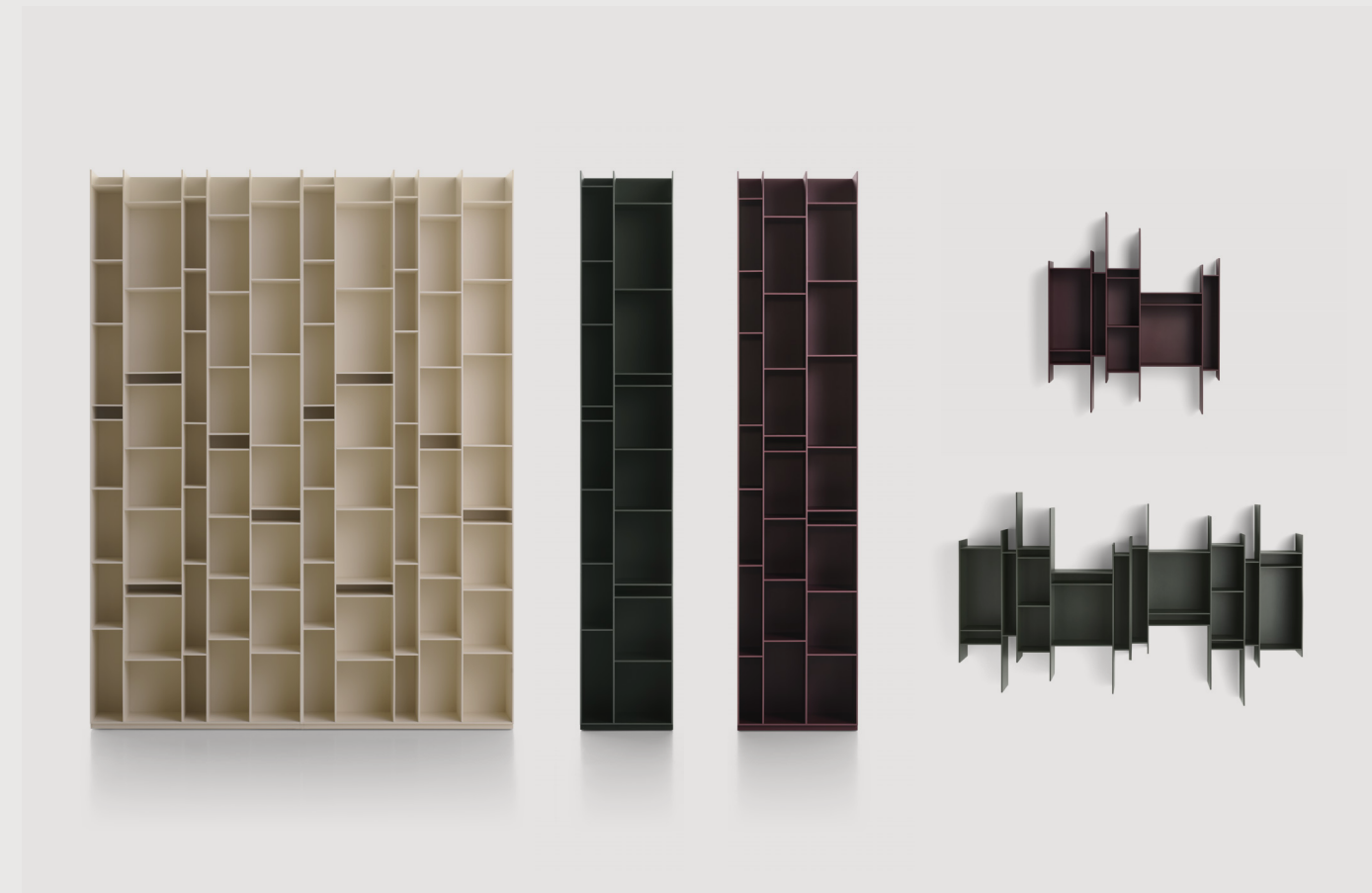
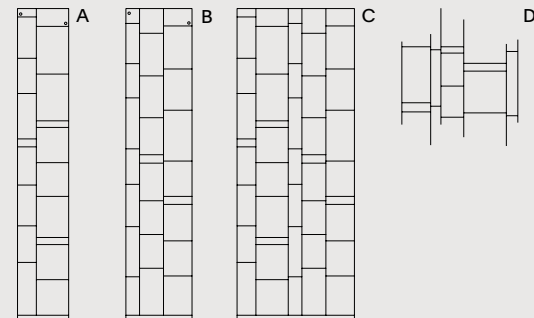



Cosy Outdoor



S Table



Neil Twist collection



EN S Table, the iconic table designed by Xavier Lust and distinguished by the iconic spiral shape of its base, explores new expressive possibilities with the introduction of a concrete version. The strength of this material, added to the existing base options, contrasts with the lightness of the form, giving the table a tactile presence that firmly places it within contemporary design discussions. The use of concrete also expands its functionality, making it suitable for outdoor spaces.

IT S Table, iconico tavolo progettato da Xavier Lust e definito dalla sinuosa torsione del basamento, esplora nuove possibilità espressive grazie all'introduzione della versione in cemento. La forza di questo materiale, aggiunto a quelli già disponibili per la base, contrasta con la leggerezza della forma, conferendo al tavolo una matericità che lo proietta con decisione nel dibattito contemporaneo. Il cemento ne amplia le possibilità d'uso, rendendolo adatto anche agli spazi outdoor.

S Table UPDATE

Designed by Xavier Lust

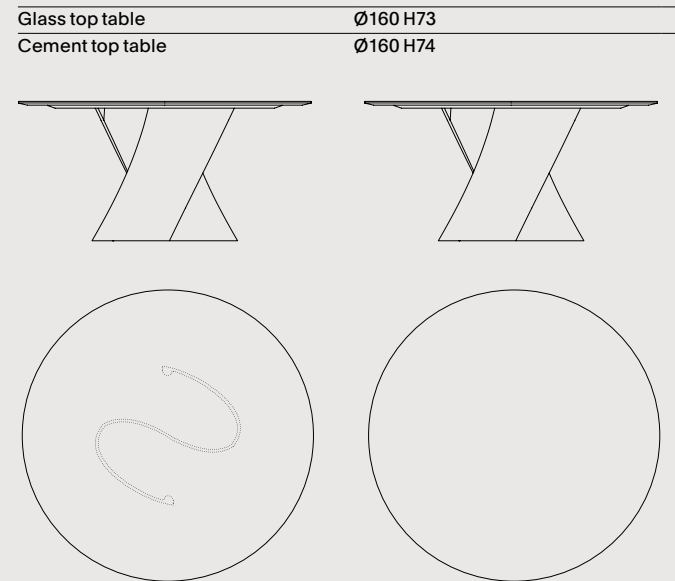

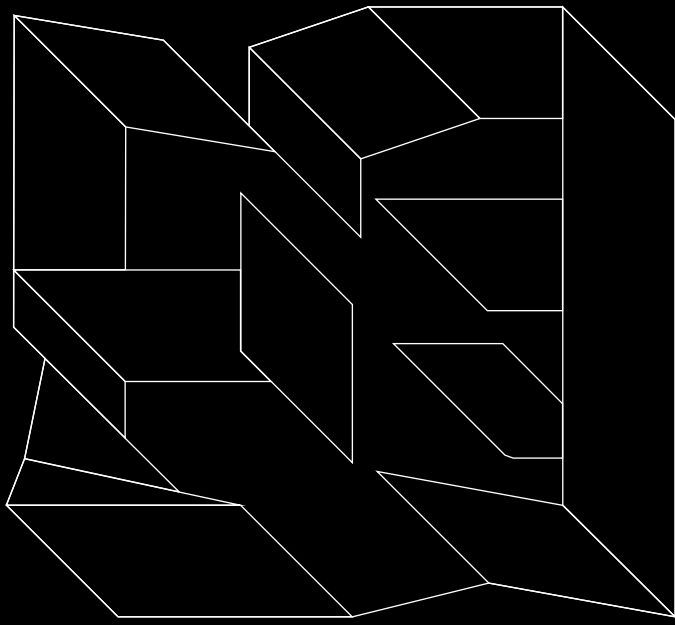

EN For the 2025 Salone del Mobile, MDF Italia entrusted Pitsou Kedem with the creation of a space where the objects themselves are the true protagonists. Soft tones and natural hues define a sequence of environments that unfold fluidly, expressing the brand's identity through a curated selection of living and dining pieces.

IT In occasione del Salone del Mobile, Pitsou Kedem ha disegnato per MDF Italia uno spazio in cui gli oggetti sono assoluti protagonisti. Tonalità morbide e sfumature naturali definiscono una serie di ambienti che si susseguono uno dopo l'altro, esprimendo l'identità dell'azienda attraverso proposte per il living e il dining.

An intimate, essential space





Archie

48



S Table

Salone del Mobile

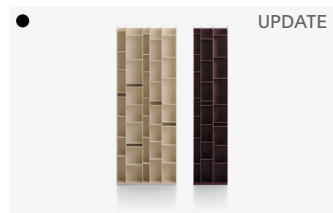

Random collection

2025

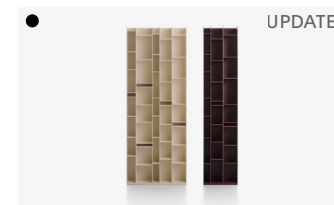

Random collection

MDF Italia



Cantle low table

News book



Cantle armchair



Goom



Cantle low table



Pentagramma



Goom



Cantile low table

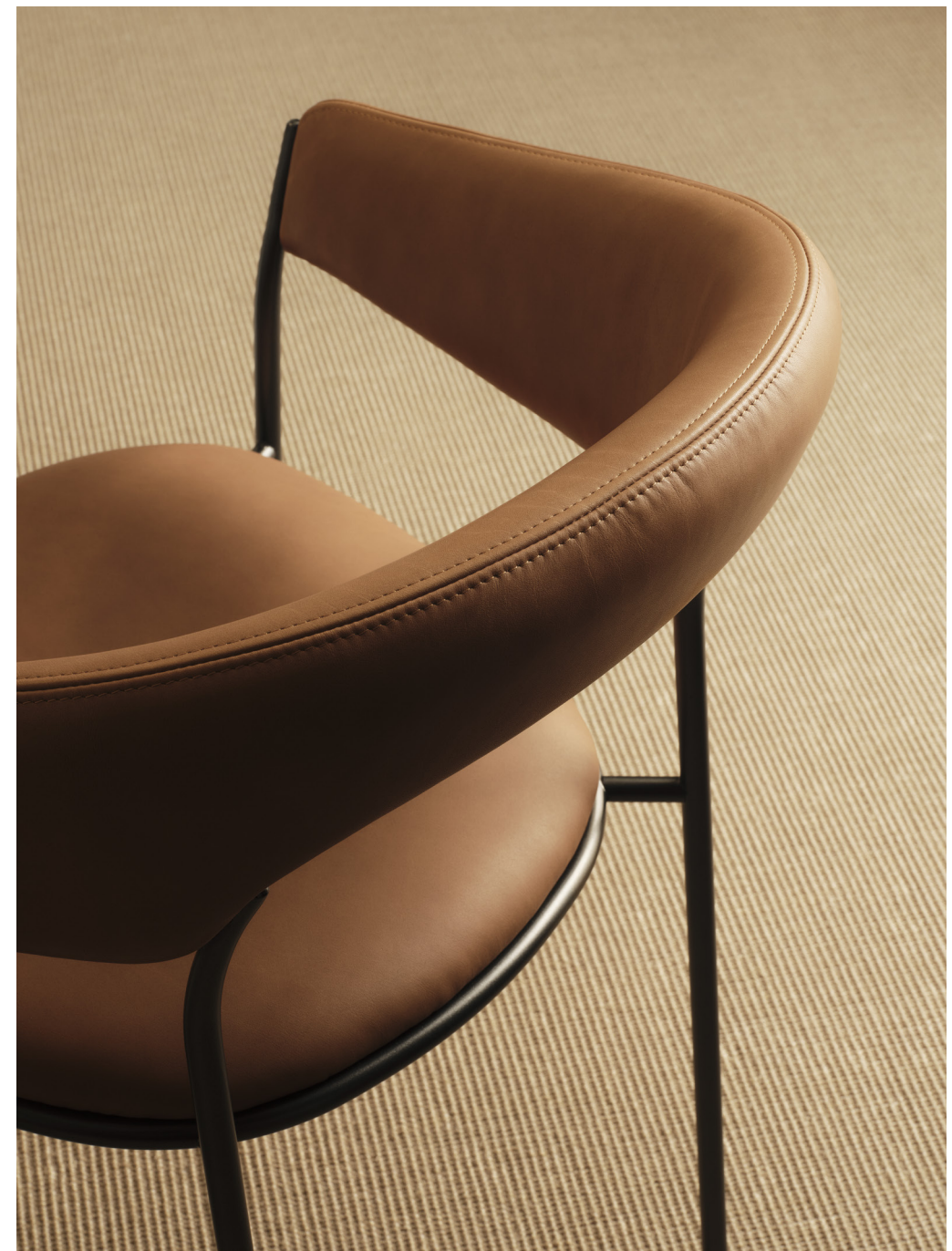

Archie



Bonnet



Cantle low table



Goom

Archie chair ^{NEW}



Design Yabu Pushelberg
Chair L59 D55 H76
seat H47

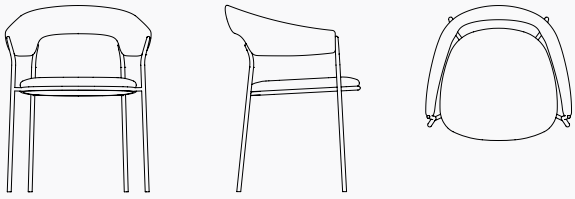

Cantle low table ^{NEW}



Design Marco Lavit
Low table
Ø45.6 H42
Ø75.2 H35
Ø104.5 H25

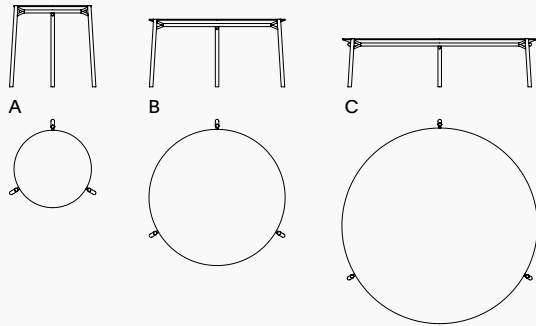

Neil Leather armchair ^{NEW}



Design Jean Marie Massaud
Armchair L78 D65 H71
seat H40



Random collection ^{UPDATE}



Design Neuland Industriedesign
2C L35.8 D25 H217
3C L46.4 D25 H217
5C L81.6 D25 H217
Randomito L81.6 P20 H96

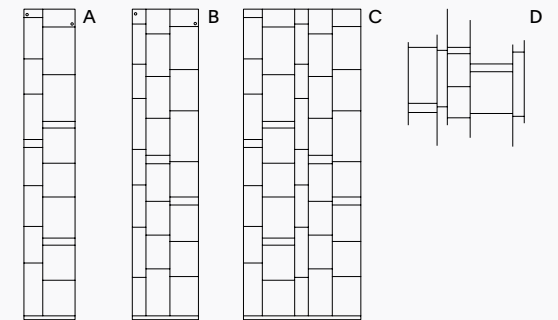

Cantle armchair



Design Marco Lavit
Armchair L75.5 D64.2 H70
seat H42

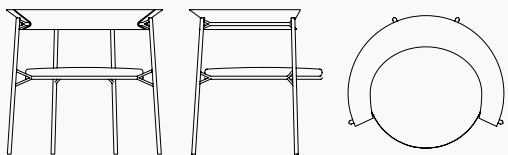

Goom sofa system ^{NEW}



Design Jean Marie Massaud
Single unit L103 D118 H76
Chaise longue unit L103 D173 H76
90° corner unit L134 D134 H76
120° corner unit L143 D134 H76
Square pouf unit L103 D103 H42
Rectangular pouf unit L103 D73 H42
Armrest for single unit and chaise longue L30 D45

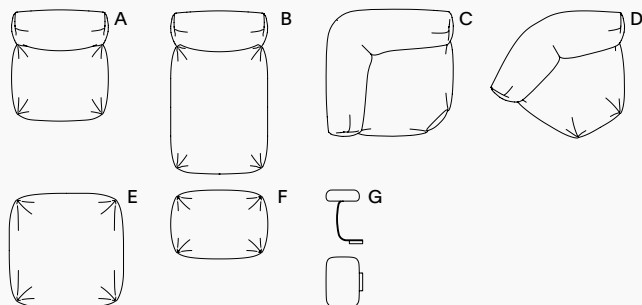

S Table ^{UPDATE}



Design Xavier Lust
Glass top table Ø160 H73
Cement top table Ø160 H74

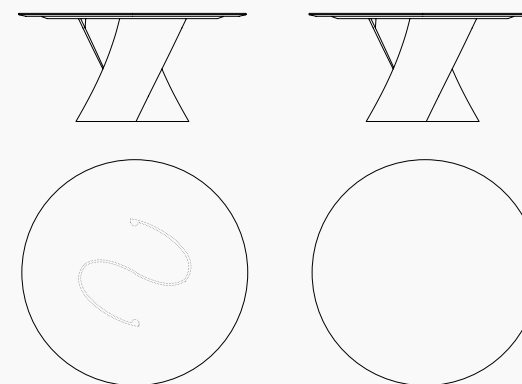

Credits

Concept

Graphic design
and drawing

Studio CCRZ

Architecture

Pitsou Kedem Architects

Mood and Styling

Enrico Pompili

Valentina Cameranesi

Digital images

Nudesign

Photo still life

Lorenzo Cappelini Baio

Photo Salone del Mobile

Thomas Pagani

Text

Cosimo Bizzarri

Lisa Cadamuro

MDF Italia marketing dept.

MDF Italia Srl Società Unipersonale

Headquarters

Via Fratelli Cervi 4/A

22066 Mariano Comense (CO)

© 2025

MDF Italia all rights reserved

MDF Italia reserves the right to change,

at any time and without prior warning,

the technical specifications of any

products illustrated in this catalogue.

mdfitalia.it

Follow us



mdf italia



