

# THE LINE

C A T A L O G  
V O L . 2

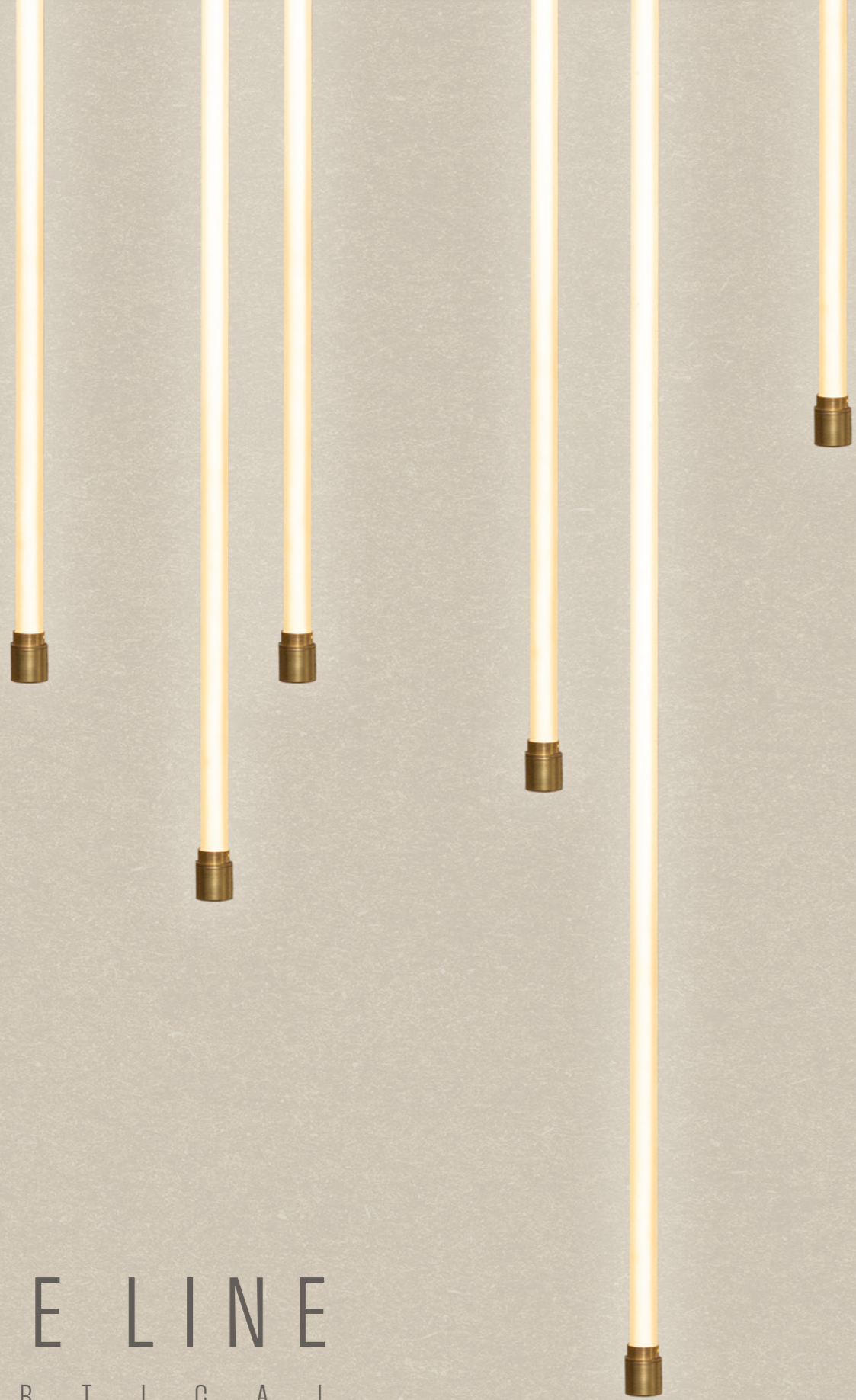

# THE LINE

V E R T I C A L

V O L . 2



# THE LINE

H O R I Z O N T A L

V O L . 2

# THE LINE

C A T A L O G  
V O L . 2

The Line è una soluzione di lampade sospese semplice e raffinata, che trasporta la luce con un design essenziale disegnando una sottile linea luminosa negli spazi abitativi. Il diffusore in vetro, sorretto da piccoli elementi di metallo alle estremità, ospita un tubo led con ottica di luce a 360°, creando atmosfere morbide ed avvolgenti, senza ombre

Le dimensioni disponibili insieme alle molteplici composizioni, unite alle finiture di Stillux, lasciano libero spazio alla progettazione di forme versatili e funzionali con infiniti giochi di design in ogni singola area.

The Line is a simple and refined solution of suspended lamps, which transports light with an essential design, drawing a thin luminous line in living spaces. The glass diffuser, supported by small metal elements at the ends, hosts a LED tube with 360° light optics, creating soft and enveloping atmospheres, without shadows. The available sizes together with the multiple compositions, combined with the Stillux finishes, leave free space for the design of versatile and functional shapes with infinite design games in each individual area



THE LINE21  
COMPOSITION

# THE LINE 21

COMPOSITION

## COMPOSITION : COMPOSIZIONE:

- N20 E\_105
- N10 C\_100

## MATERIALS: MATERIALI:



Ottone Satinato  
Satin brass



Pyrex

## COMPOSITION SHEETS: DISEGNI COMPOSIZIONE:

- E\_105

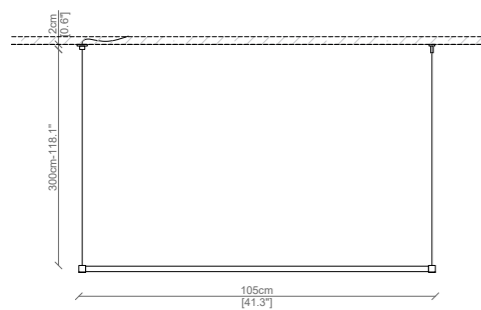

- C\_100

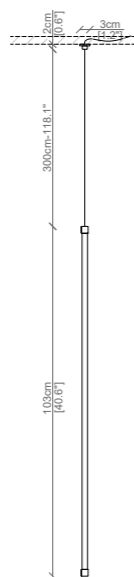



# THE LINE 22

COMPOSITION

## COMPOSITION : COMPOSIZIONE:

- N° 18 E\_105
- N° 9 C\_100

## MATERIALS: MATERIALI:



Ottone Satinato  
Satin brass



Pyrex

## COMPOSITION SHEETS: DISEGNI COMPOSIZIONE:

- E\_105

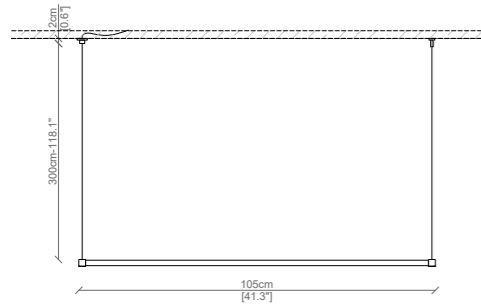

- C\_100

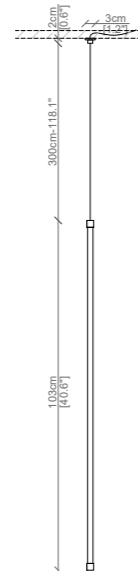

# THE LINE 23

COMPOSITION

**COMPOSITION :**  
COMPOSIZIONE:

• N° 50 C\_75

**MATERIALS:**  
MATERIALI:



Ottone Satinato  
Satin brass



Pyrex



# THE LINE 24

COMPOSITION WALL

# THE LINE 25

COMPOSITION CEILING

COMPOSITION :  
COMPOSIZIONE:

N° 20 C\_150

COMPOSITION :  
COMPOSIZIONE:

N° 100 C\_75

# THE LINE 26

COMPOSITION

## COMPOSITION : COMPOSIZIONE:

- N° 3 E\_150
- N° 3 E\_75
- N° 4 C\_50

## MATERIALS: MATERIALI:



Ottone Satinato  
Satin brass



Pyrex

## COMPOSITION SHEETS: DISEGNI COMPOSIZIONE:

- E\_150

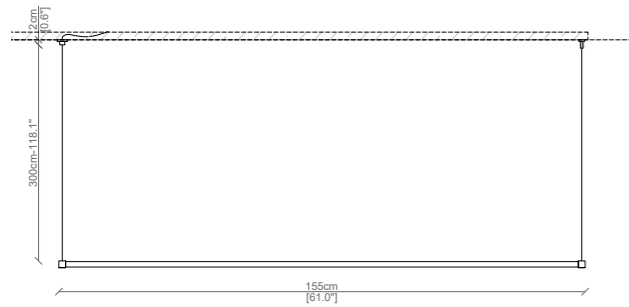

- E\_75

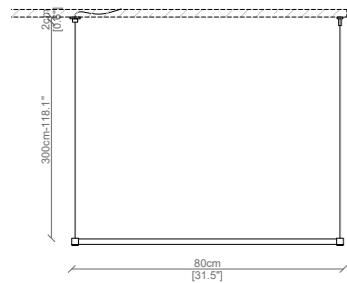

- C\_50

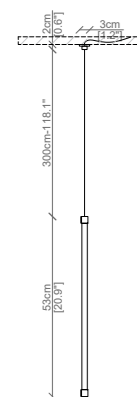



# THE LINE 27

COMPOSITION

**COMPOSITION :**  
COMPOSIZIONE:

- N° 19 E\_75 ( FIRST RING )
- N° 13 E\_75 ( SECOND RING )
- N° 10 E\_75 ( THIRD RING )
- N° 10 E\_75 ( FORTH RING )

**MATERIALS:**  
MATERIALI:



Ottone Satinato  
Satin brass



Pyrex

**COMPOSITION SHEETS:**  
DISEGNI COMPOSIZIONE:

- E\_75

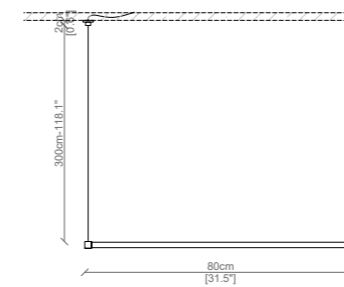



# THE LINE 28

COMPOSITION

## COMPOSITION : COMPOSIZIONE:

- N° 2 E\_150
- N° 6 E\_105
- N° 5 C\_75

## MATERIALS: MATERIALI:



Ottone Satinato  
Satin brass



Pyrex

## COMPOSITION SHEETS: DISEGNI COMPOSIZIONE:

- E\_150

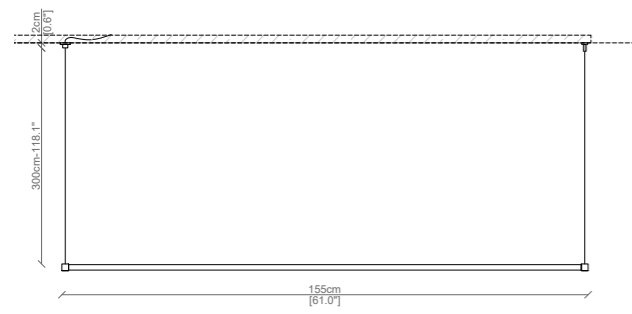

- E\_105

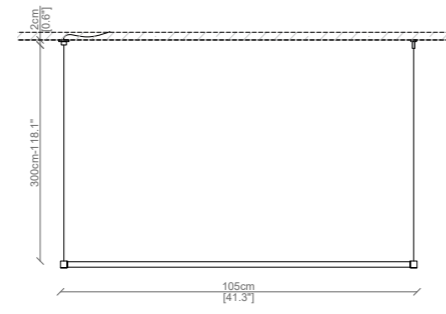

- C\_75

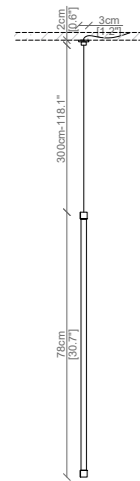



# THE LINE 29

COMPOSITION

**COMPOSITION :**  
COMPOSIZIONE:

- N° 3 E\_150
- N° 2 C\_75
- N° 3 E\_75 (N2 NIGHT TABLES)

**MATERIALS:**  
MATERIALI:



Ottone Satinato  
Satin brass



Pyrex

**COMPOSITION SHEETS:**  
DISEGNI COMPOSIZIONE:

- E\_150

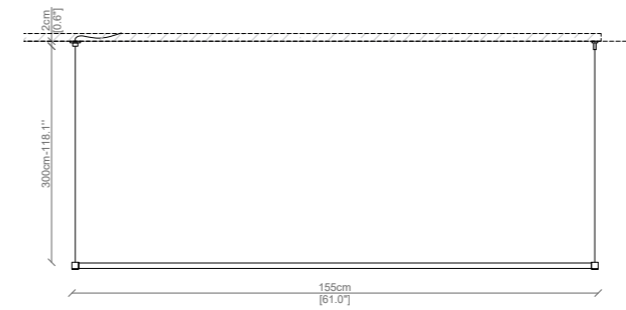

- E\_75

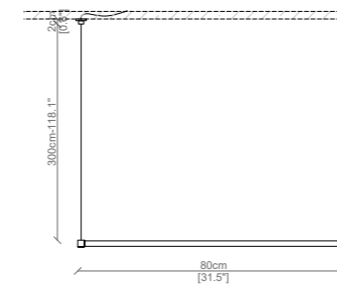

- C\_75

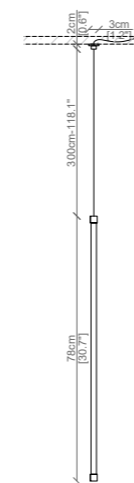







# THE LINE 30

COMPOSITION

**COMPOSITION :**  
COMPOSIZIONE:

- N° 12 E\_50
- N° 6 C\_50

**MATERIALS:**  
MATERIALI:



Ottone Satinato  
Satin brass



Pyrex

**COMPOSITION SHEETS:**  
DISEGNI COMPOSIZIONE:

• E\_50

• C\_50

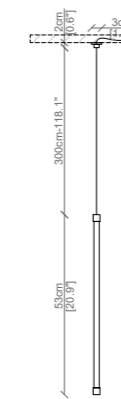
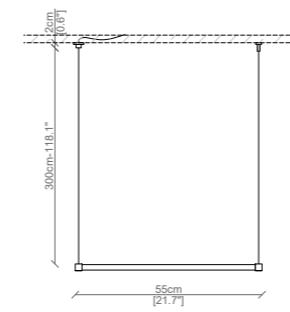

# THE LINE 31

COMPOSITION

**COMPOSITION :**  
COMPOSIZIONE:

- N° 50 C\_50

**COMPOSITION SHEETS:**  
DISEGNI COMPOSIZIONE:

- C\_50

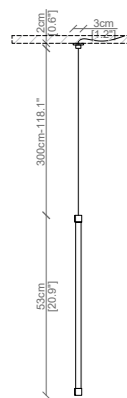

**MATERIALS:**  
MATERIALI:



Ottone Satinato  
Satin brass



Pyrex

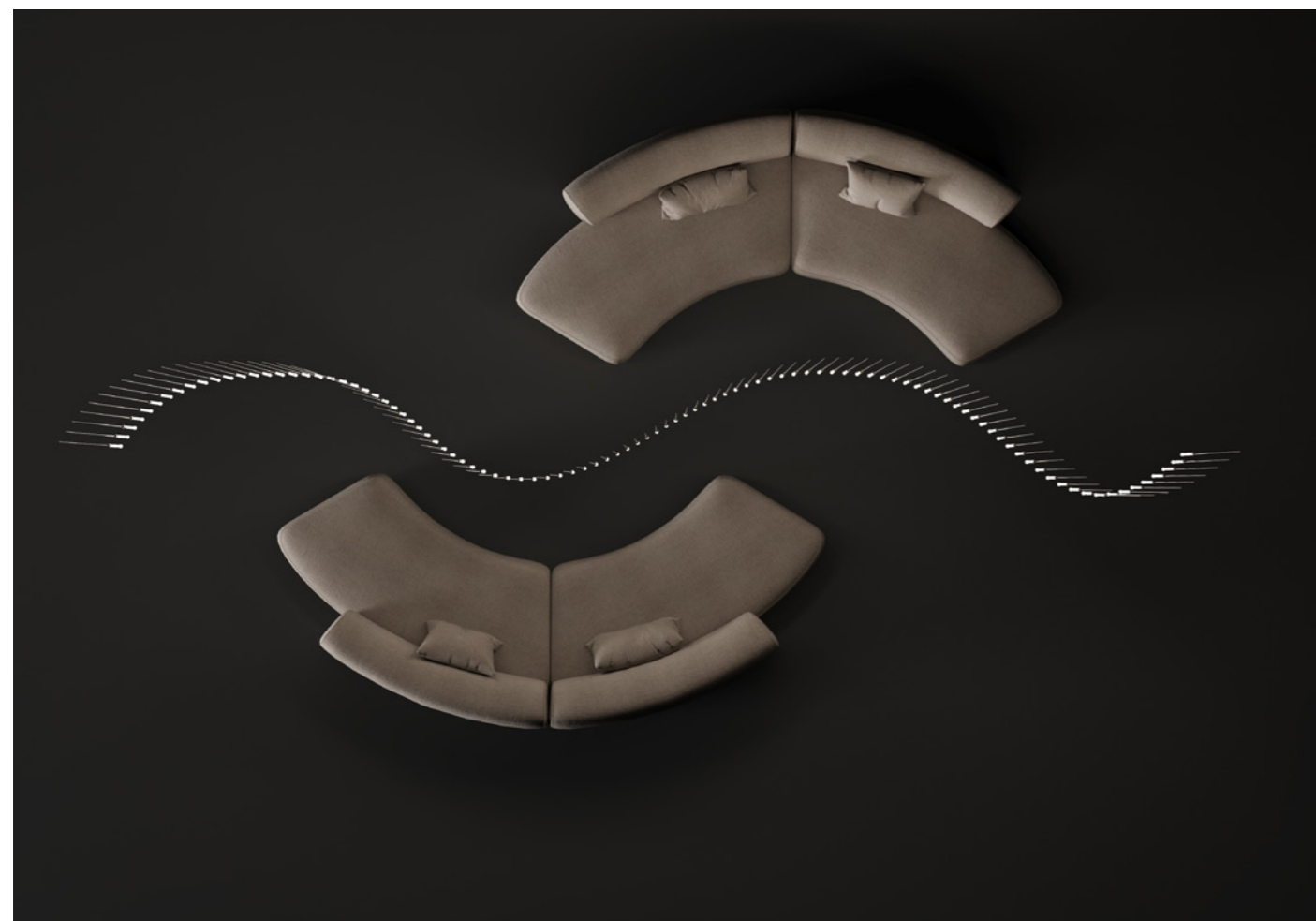

# THE LINE 32

COMPOSITION

**COMPOSITION :**  
COMPOSIZIONE:

- N° 100 C\_75

**COMPOSITION SHEETS:**  
DISEGNI COMPOSIZIONE:

- C\_50

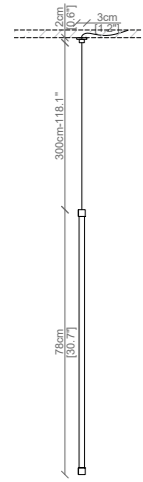

**MATERIALS:**  
MATERIALI:



Ottone Satinato  
Satin brass



Pyrex



# THE LINE 33

COMPOSITION



COMPOSITION WITH THE SAME CANOPY  
DIAM 100CM

# THE LINE 33

COMPOSITION

**COMPOSITION :**  
COMPOSIZIONE:

- N° 50 C\_75

# THE LINE 34

COMPOSITION

**COMPOSITION :**  
COMPOSIZIONE:

- N° 50 C\_100

# THE LINE 35

COMPOSITION

**COMPOSITION :**  
COMPOSIZIONE:

- N° 50 C\_75

# THE LINE 34

COMPOSITION



# THE LINE 35

COMPOSITION

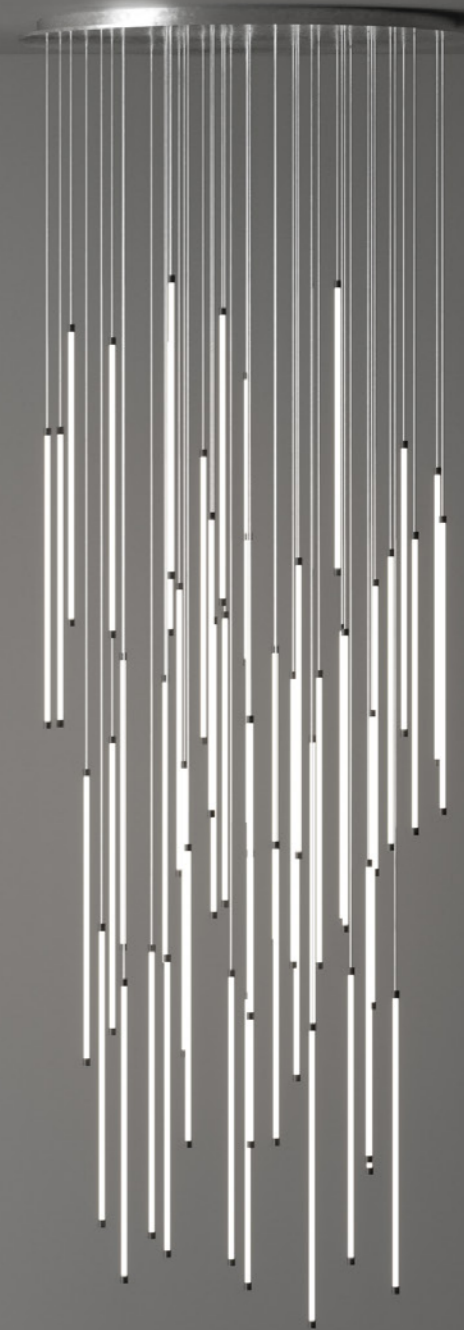

# THE LINE 36

COMPOSITION

**COMPOSITION :**  
COMPOSIZIONE:

- N° 75 C\_100

**COMPOSITION SHEETS:**  
DISEGNI COMPOSIZIONE:

- C\_100

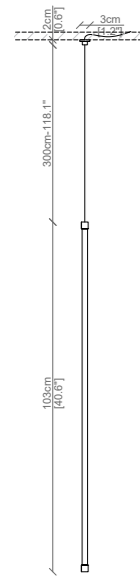

**MATERIALS:**  
MATERIALI:



Ottone Satinato  
Satin brass



Pyrex



# THE LINE 37

COMPOSITION

**COMPOSITION :**  
COMPOSIZIONE:

- N° 25 C\_150

**COMPOSITION SHEETS:**  
DISEGNI COMPOSIZIONE:

- C\_150

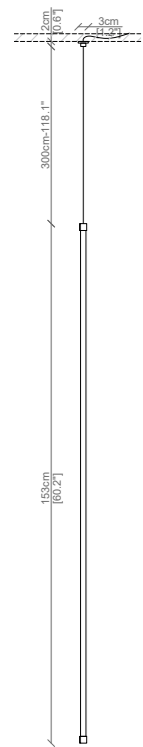

**MATERIALS:**  
MATERIALI:



Ottone Satinato  
Satin brass



Pyrex



# THE LINE 38

COMPOSITION

## COMPOSITION : COMPOSIZIONE:

- N° 28 C\_50 ( FIRST RING)
- N°14 C\_100 ( SECOND RING)

## MATERIALS: MATERIALI:



Ottone Satinato  
Satin brass



Pyrex

## COMPOSITION SHEETS: DISEGNI COMPOSIZIONE:

- C\_100 • 50

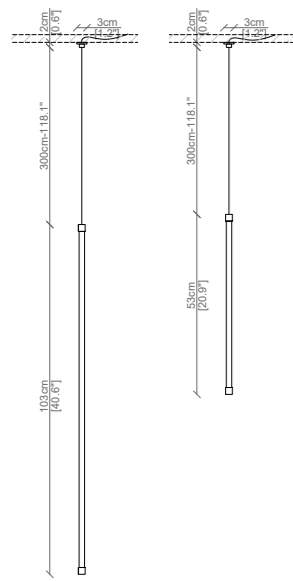

# THE LINE 39

COMPOSITION

**COMPOSITION :**  
COMPOSIZIONE:

- N° 9 E\_50
- N° 6 C\_50

**MATERIALS:**  
MATERIALI:



Ottone Satinato  
Satin brass



Pyrex

**COMPOSITION SHEETS:**  
DISEGNI COMPOSIZIONE:

- E\_50

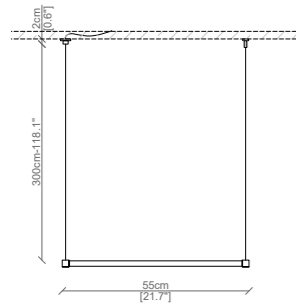

- C\_50

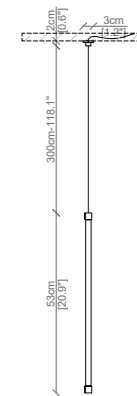

# THE LINE 40

COMPOSITION

**COMPOSITION :**  
COMPOSIZIONE:

- N° 25 C\_100

**COMPOSITION SHEETS:**  
DISEGNI COMPOSIZIONE:

- C\_100

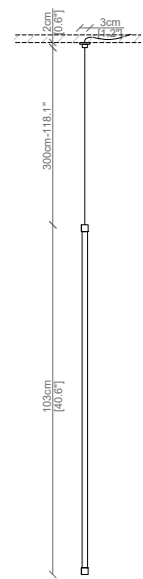

**MATERIALS:**  
MATERIALI:



Ottone Satinato  
Satin brass



Pyrex







# THE LINE 41

COMPOSITION

**COMPOSITION :**  
COMPOSIZIONE:

- N° 12 E\_75
- N° 4 E\_50

**MATERIALS:**  
MATERIALI:

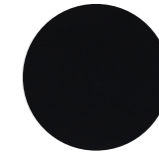

Nero velluto  
Black velvet



Pyrex

**COMPOSITION SHEETS:**  
DISEGNI COMPOSIZIONE:

• E\_50

• E\_75

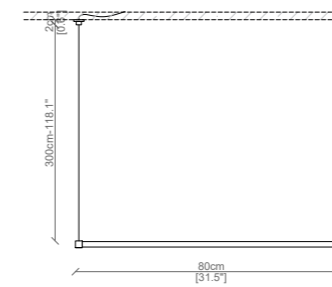
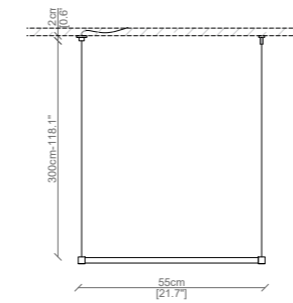





# THE LINE 42

COMPOSITION

**COMPOSITION :**  
COMPOSIZIONE:

- N° 4 C\_75
- N° 4 E\_50
- N° 4 E\_105

**MATERIALS:**  
MATERIALI:



Chromo



Pyrex

**COMPOSITION SHEETS:**  
DISEGNI COMPOSIZIONE:

- E\_50

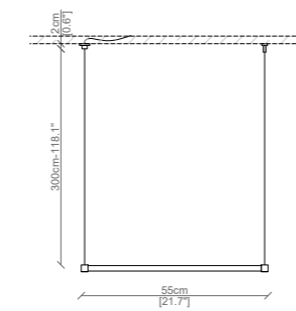

- E\_105

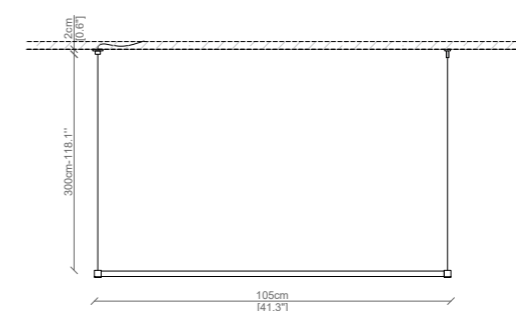

- C\_75

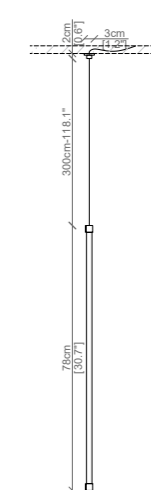

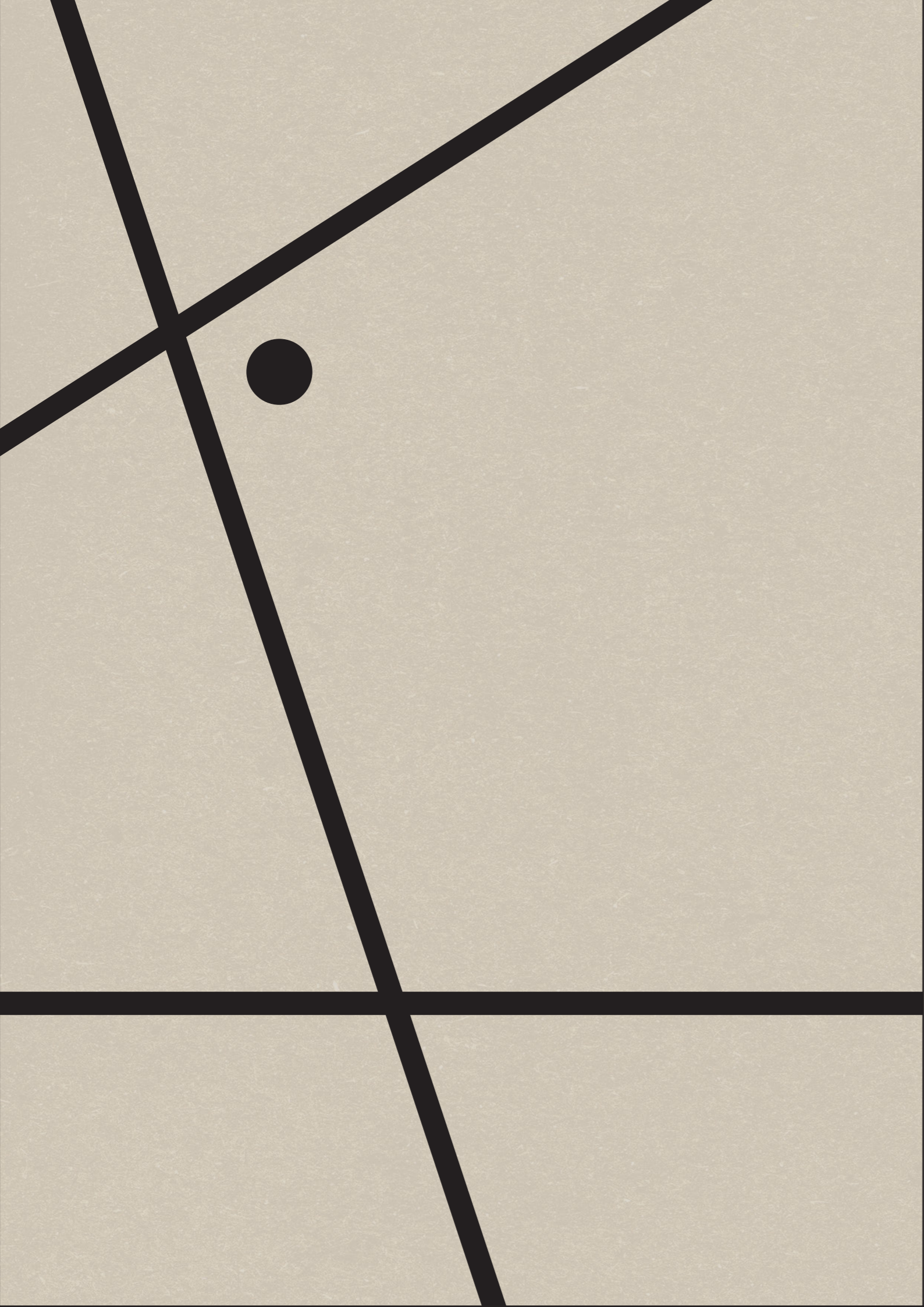

DISEGNI TECNICI  
TECHNICAL SHEETS

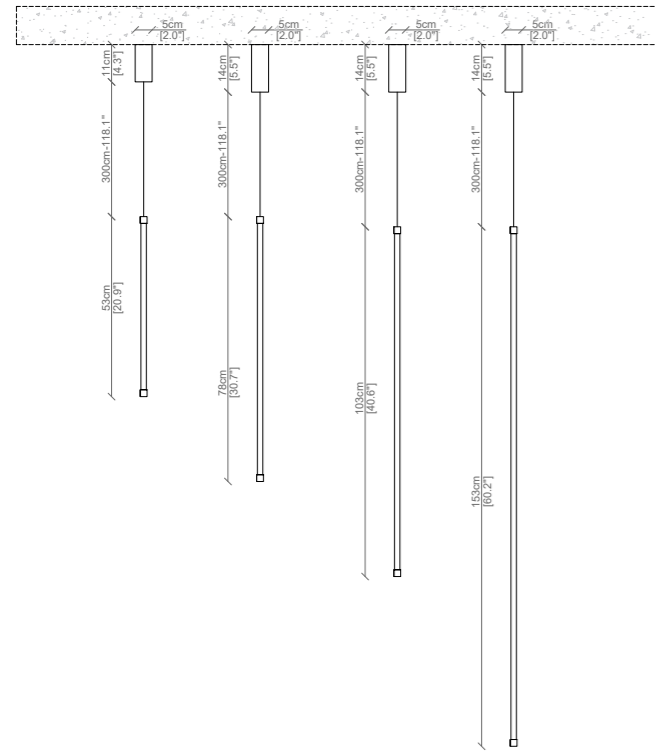

COMPOSIZIONI VERTICALI - A

Installazione per composizioni verticali, con rosone ed alimentazione indipendente (alimentatore incluso)  
 Misure disponibili standard cm.53, 78, 103, 153 (20,9", 30,7", 40,6", 60,2")  
 Installation for vertical compositions, with canopy and independent power supply (driver included)  
 Standard available sizes cm.53, 78, 103, 153 (20,9", 30,7", 40,6", 60,2")

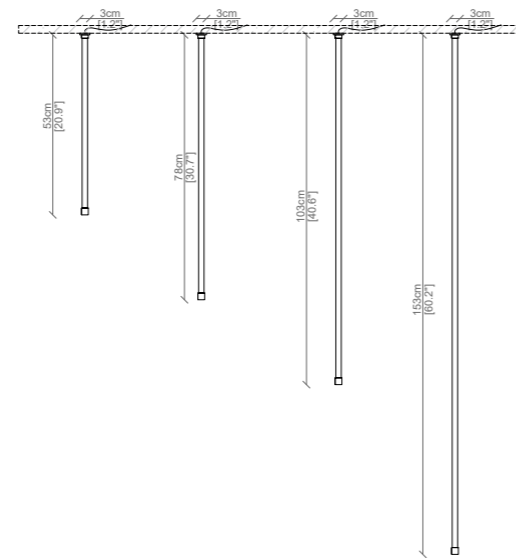

COMPOSIZIONI VERTICALI - B

Installazione per composizioni verticali, con attacco diretto al soffitto ed alimentazione in remoto  
 Misure disponibili standard cm.53, 73, 103, 153 (20,9", 28,7", 40,6", 60,2")  
 Installation for vertical compositions, with direct ceiling block and remote power supply  
 Standard available sizes cm.53, 73, 103, 153 (20,9", 28,7", 40,6", 60,2")

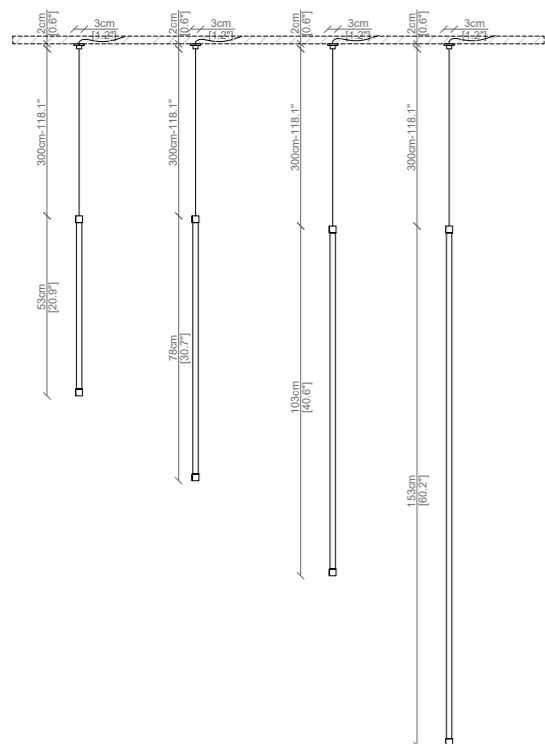

COMPOSIZIONI VERTICALI - C

Installazione per composizioni verticali con controsoffitti ed alimentazione in remoto  
 Misure disponibili standard cm.53, 73, 103, 153 (20,9", 28,7", 40,6", 60,2")  
 Installation for vertical compositions, with false ceilings and remote power supply  
 Standard available sizes cm.53, 73, 103, 153 (20,9", 28,7", 40,6", 60,2")

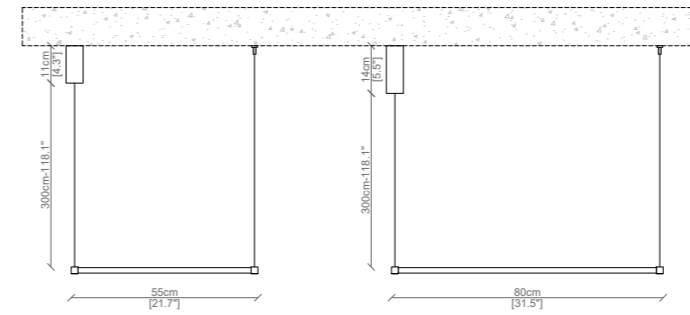

COMPOSIZIONI ORIZZONTALI - D

Installazione per composizioni orizzontali con rosone ed alimentazione indipendente (alimentatore incluso)  
 Misure disponibili standard cm.55, 80, 105, 155 (21,7", 31,5", 41,3", 61,0")  
 Installation for horizontal compositions, with canopy and independent power supply (driver included)  
 Standard available sizes cm.55, 80, 105, 155 (21,7", 31,5", 41,3", 61,0")

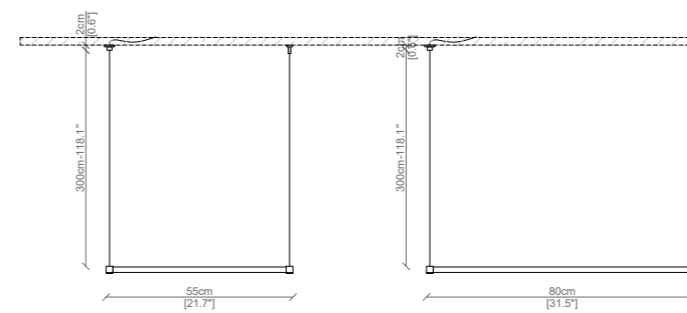
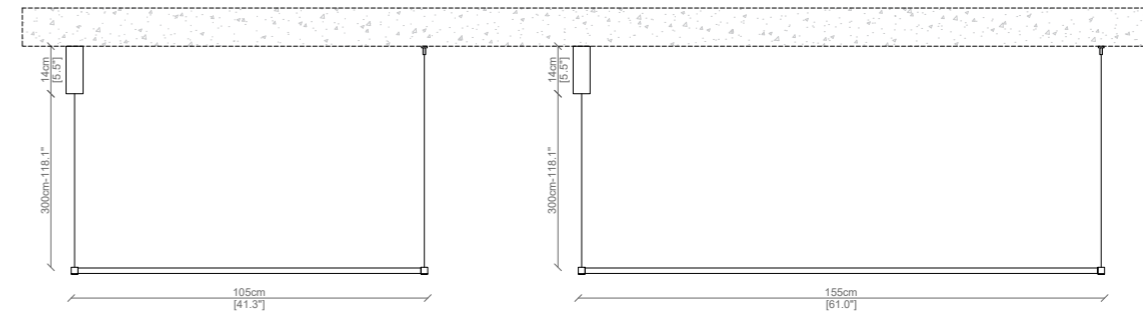

COMPOSIZIONI ORIZZONTALI - E

Installazione per composizioni orizzontali con controsoffitti ed alimentazione in remoto  
 Misure disponibili standard cm. cm.55, 80, 105, 155 (21,7", 31,5", 41,3", 61,0")  
 Installation for horizontal compositions, with false ceilings and remote power supply  
 Standard available sizes cm.55, 80, 105, 155 (21,7", 31,5", 41,3", 61,0")

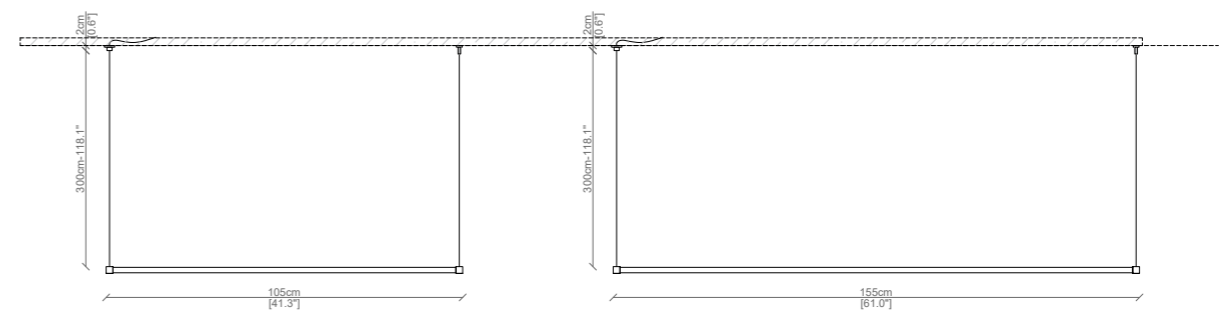

FINITURE DISPONIBILI - AVAILABLE FINISHES

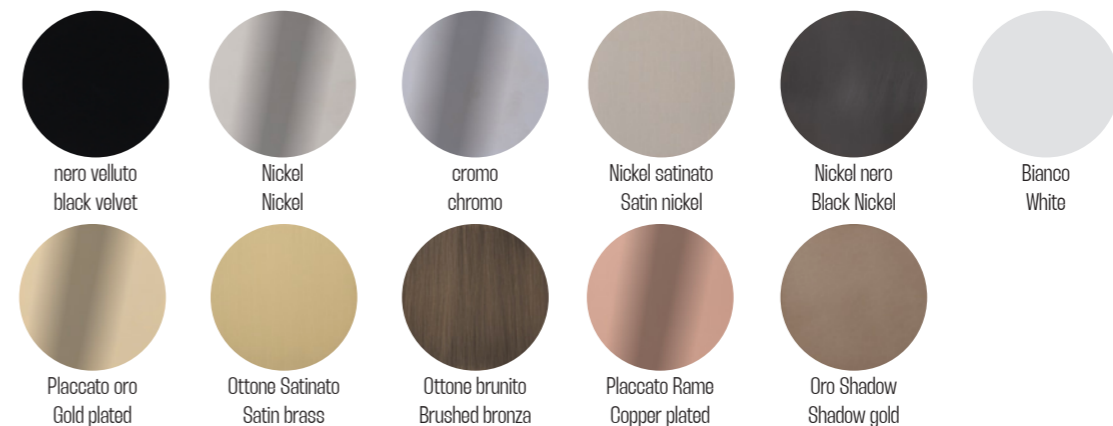

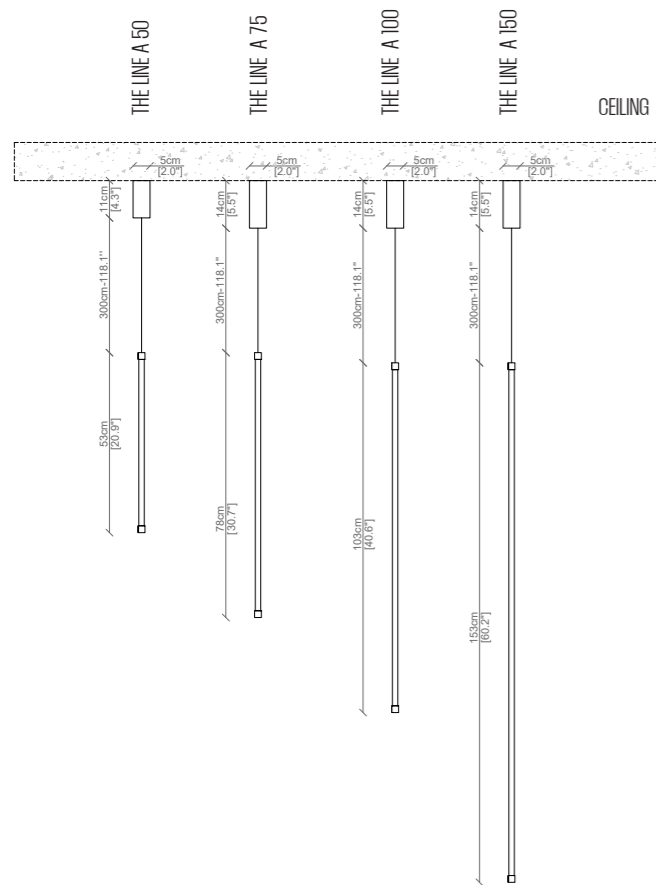

THE LINE 50 A

6w - 400 Lumen -3000k

THE LINE 75 A

9w - 600 Lumen -3000k

THE LINE 100 A

12w - 800 Lumen -3000k

THE LINE 150 A

18w - 1200 Lumen -3000k

Tubo LED con ottica di luce a 360°, alta efficienza luminosa e distribuzione uniforme della luce.  
Alimentazione 24Vdc, 3000K, dimmerabile

LED tube with 360° light optics, high luminous efficiency and uniform light distribution.  
Power supply 24Vdc, 3000K, dimmerable

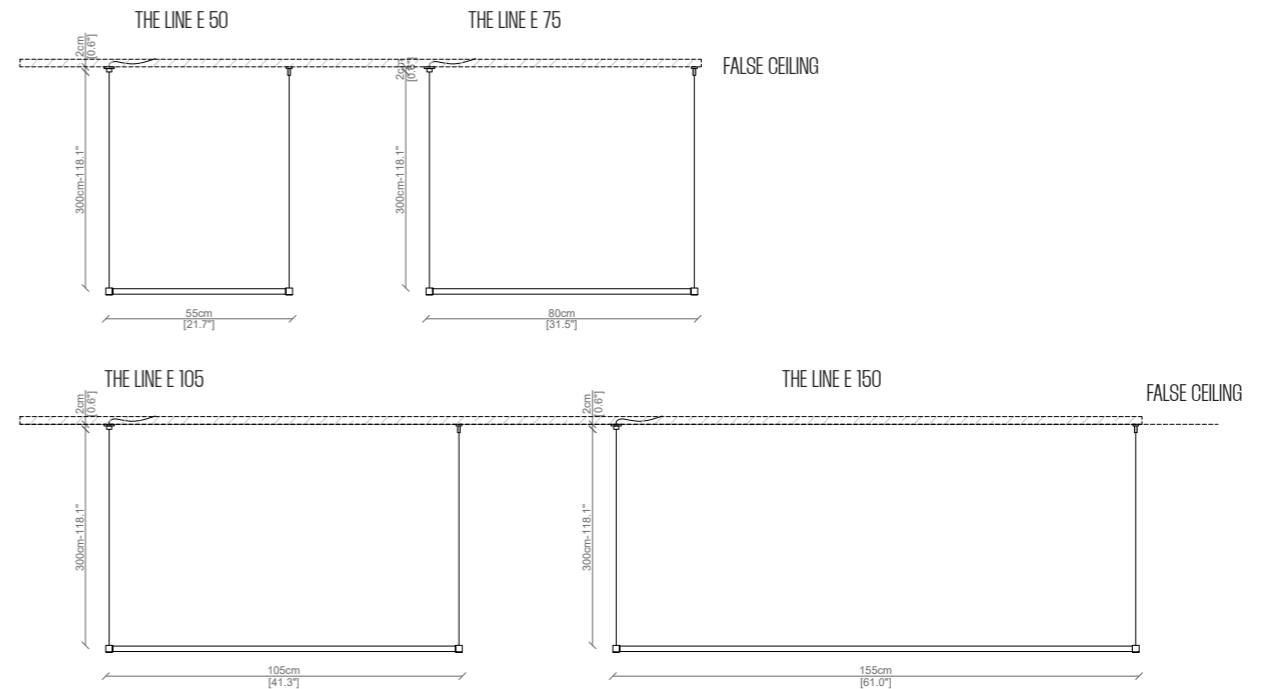
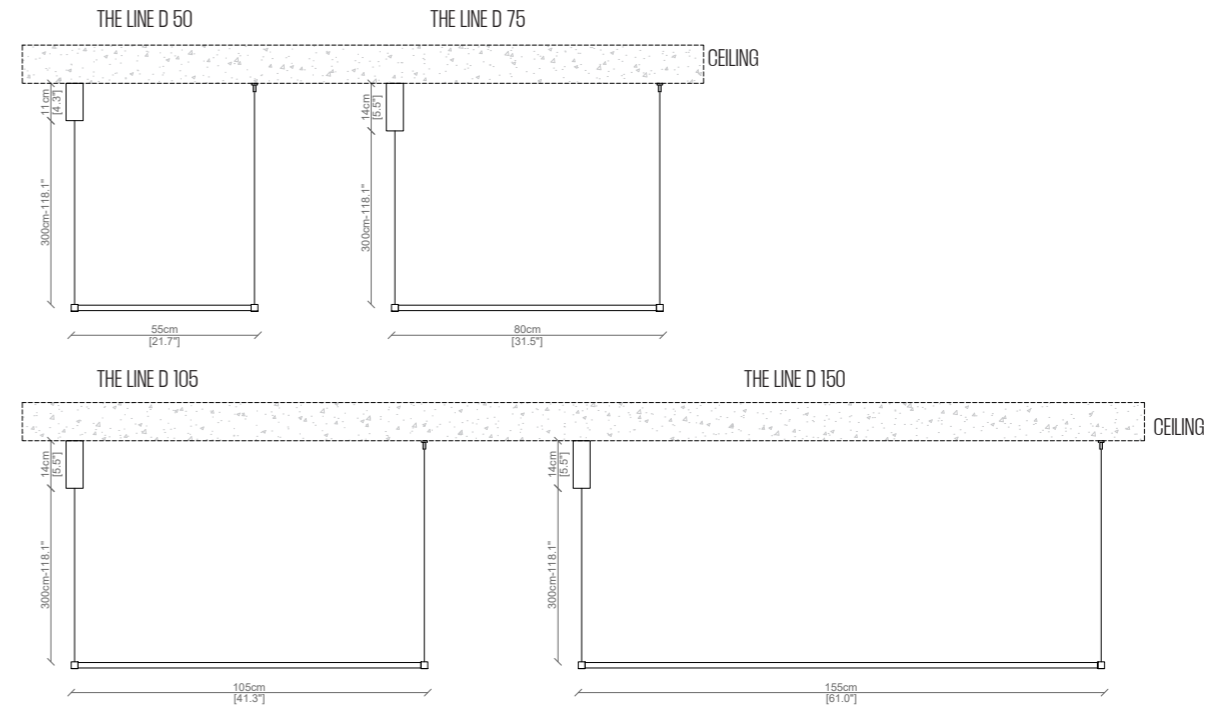
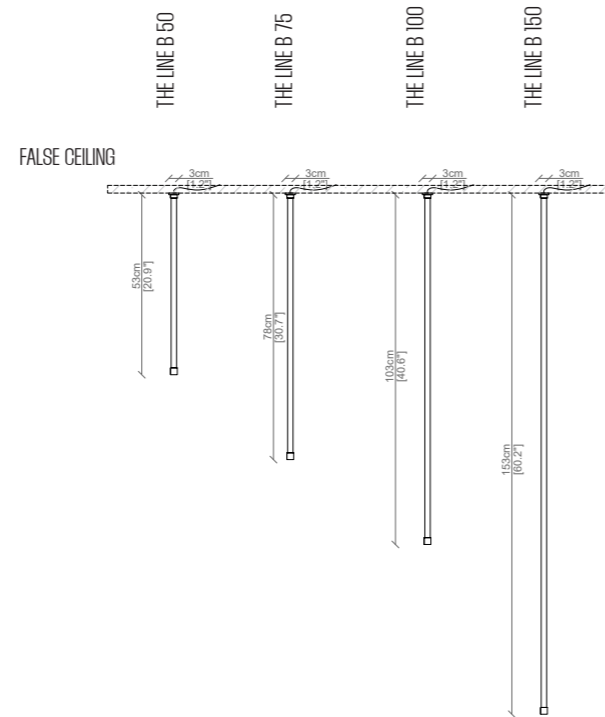
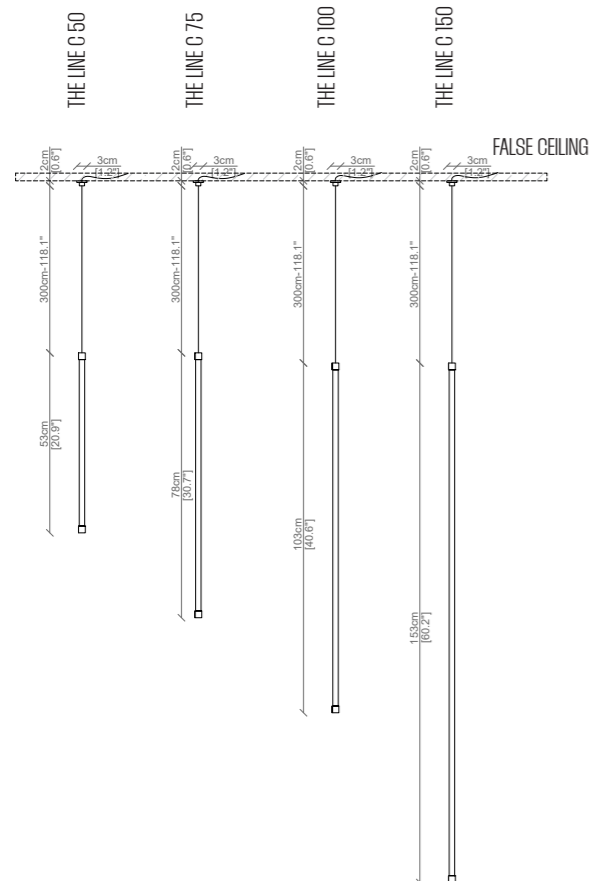

USA CANOPY FOR CIMPOSITION THE LINE "A" & "D"

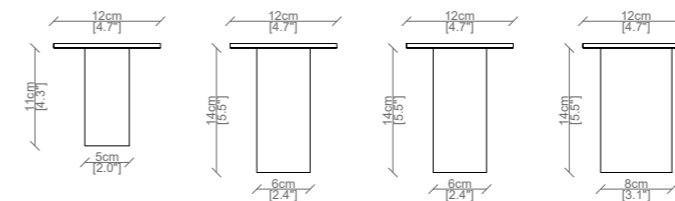



Stillux Srl realizza tutte le sue collezioni in Italia usando componenti e materie prime selezionate.

All the Stillux Srl collections are manufactured 100% in Italy using top class components and materials.

Stillux Srl si riserva il diritto di apportare, senza preavviso, ogni modifica mirata al miglioramento funzionale e qualitativo dei propri prodotti. Testi e disegni presenti in questo stampato hanno scopo divulgativo: per ogni aspetto tecnico e dimensionale fare riferimento ai listini aziendali e relativi aggiornamenti. I campioni di colori e materiali hanno valore indicativo.

Stillux Srl reserves the rights at all time to apply modifications for the functional or qualitative improvement of its products. Texts and drawings present in this brochure have a divulgative purpose: for every technical and dimensional aspect please refer to the company's price lists and their relative updatings. The colour and material samples have an indicative value.

DESIGNER	Marco Innocenti ( Creative Mind Stillux )
ART DIRECTION	Andrea Mosti
PHOTOGRAPHY	Andrea Mosti
RENDERING	Andrea Mosti
COLOR SEPERATION	Andrea Mosti
PRESS STAMP	Cartograficatoscana



[www.stillux.it](http://www.stillux.it)



Instagram

Via Ponte Cerretano, 9/17, 50050 Cerreto Guidi - Firenze - Italy

Email: [stillux@stillux.it](mailto:stillux@stillux.it) +39 0571 501403

P.IVA 04610250484