

GRAY CLUB TAPIES JORN COLLECTIONS



GERVASONI

1882

**GRAY, CLUB, TAPIES, JORN,
MEDLEY, PIER, STRAP, R 513, SANTÉ
COLLECTIONS**

GERVASONI

1882

(I) Ci sono oggetti che attraversano il tempo senza perdere la propria voce. Si stabiliscono negli spazi, li definiscono con discrezione, acquistano familiarità senza mai perdere il proprio carattere. Madie, tavolini, lampade, divani, sedute e tavoli convivono nel linguaggio Gervasoni, insieme alla collezione Gray. Il disegno essenziale, il dialogo con il legno, le proporzioni attentamente calibrate definiscono un'identità precisa, capace di adattarsi con uguale naturalezza alla domesticità quotidiana e alla formalità di contesti più rappresentativi. Una sensibilità progettuale che in Gervasoni trasforma la materia in qualcosa da abitare.

(E) There are objects that move through time without ever losing their voice. They settle into spaces, defining them with discretion, becoming familiar without ever losing their character. Sideboards, coffee tables, lamps, sofas, seating and tables coexist within the Gervasoni language, together with the Gray collection. Essential design, a dialogue with wood and carefully balanced proportions define a clear identity, capable of adapting with equal ease to everyday domestic settings and more formal, representative interiors. A design sensibility that, at Gervasoni, transforms material into something to be lived with.

(F) Il existe des objets qui traversent le temps sans jamais perdre leur voix. Ils s'installent dans les espaces, les définissent avec discrétion, deviennent familiers sans jamais perdre leur caractère. Buffets, tables basses, lampes, canapés, assises et tables coexistent dans le langage Gervasoni, aux côtés de la collection Gray. Un dessin essentiel, un dialogue avec le bois et des proportions soigneusement équilibrées définissent une identité précise, capable de s'adapter avec la même aisance à l'espace domestique quotidien qu'à des contextes plus formels et représentatifs. Une sensibilité de projet qui, chez Gervasoni, transforme la matière en quelque chose à habiter.

(D) Es gibt Objekte, die die Zeit überdauern, ohne ihre eigene Stimme zu verlieren. Sie fügen sich in Räume ein, definieren sie mit Zurückhaltung und werden vertraut, ohne jemals ihren Charakter zu verlieren. Sideboards, Beistelltische, Leuchten, Sofas, Sitzmöbel und Tische koexistieren in der Formensprache von Gervasoni zusammen mit der Kollektion Gray. Ein essentielles Design, der Dialog mit dem Holz und sorgfältig ausbalancierte Proportionen definieren eine klare Identität, die sich gleichermaßen selbstverständlich in den alltäglichen Wohnraum wie in repräsentativere, formellere Kontexte einfügt. Eine gestalterische Sensibilität, die bei Gervasoni das Material in etwas verwandelt, das man bewohnen kann.





Index

1.
Warm Elegance
p. 006—047

2.
Light Geometry
p. 048—093

3.
Architectural Living
p. 094—129

**Technical
Info**
p. 130—151

**Abacus
by Categories**
p. 152—159

Warm Elegance



↓ Club configuration 06: Divano modulare / Modular sofa in Grande Bouclé Calais – D.

↓ Tapies 69: Madia / Sideboard, Gypsum finish.

Kira 98

Tapies 69

R 513 p

Club configuration 06

Heiko 42



Club configuration 06



Kira 98

R 513 p

↑ R 513 p: Poltrona/ Armchair.
Cuscino/ Cushion in Sand Bianca - C.



Heiko 42, 43

Club 14

Heiko 41

↑ Club 14: Divano/ Sofa in Soil Saline - E.
Loose cushions: 2 C. Club XS in
Soil Saline - E, Soil Loamy - E.



Club 14



↓→ Tapiés 69: Madia/
Sideboard, Gypsum finish.





Loll 223

Gray 32

☞ Gray 32: Tavolo quadrato.
Gambe in ceramica bianca.
Piano in lamiera di ferro cerata/
Square table. White ceramic
legs. Waxed iron sheet top.

☞ Loll 223: Poltroncina dining/
Dining armchair in Grande
Bouclé Nantes - D.



020



021

Warm Elegance



Gray 08

Brise 53, 54

Gray 05

➤ Gray 08: Poltroncina / Armchair. Struttura in frassino tinto Maple / Frame in Maple-stained ash. Tessuto / Fabric Sand Majore - C (stitching Perla).

➤ Gray 05: Divanetto / Loveseat. Struttura in frassino tinto Maple / Frame in Maple-stained ash. Seduta / Seat in Sand Zingaro - C. Cuscini / Cushions: 70x70 in Grande Bouclé Calais - D, 60x60 in Sand Zingaro - C, 50x50 in Grande Bouclé Calais - D.

→ Gray 06: Poltrona/ Armchair.
Struttura in frassino tinto Maple/
Frame in Maple-stained ash.
Seduta/ Seat in Sand Majore - C.
Cuscini/ Cushions: 70x70 in Grande
Bouclé Limoges - D.



Gray 06



Silver 95

Club 223

Club 132

↑ Club 132: Tavolo quadrato/ Square table.
Gambe in frassino tinto Charcoal. Piano in
vetro Blueberry./ Legs in Charcoal-stained ash.
Blueberry glass top.

↑ Club 223: Sedia/ Chair. Struttura in
frassino tinto Charcoal / Frame in Charcoal
-stained ash. Tessuto / Fabric Deus
Mercurio - C.



Club 223



Club 132



↑→ Club 132: Tavolo quadrato/ Square table. Gambe in frassino tinto Charcoal. Piano in gres Calacatta oro./ Legs in Charcoal-stained ash. Calacatta oro stoneware top.



Club 224

Club 132

↑→ Club 224: Sedia con braccioli/ Armchair. Struttura in frassino tinto Charcoal / Frame in Charcoal-stained ash. Tessuto / Fabric Movida Cadice - D.



↔ Club configuration 07:
Divano modulare/ Modular sofa
in Mountains Latemar – C.
Loose cushions: 2 C. Club XS
in Soil Loamy - E, Soil Saline - E.

↔ Loll 09: Poltrona/
Armchair in new
Polar Bear - D.

Club configuration 07

Heiko 43

Loll 09



Loll 09

Heiko 41



→ Gray 38: Tavolo rotondo/ Round table Ø 140 cm. Base in Millgres bianco. Piano a doghe in frassino tinto Chalkwood./ White Millgres base. Slatted top in Chalkwood-stained ash.

→ Gray 22: Sedia/ Chair. Struttura in frassino tinto Charcoal / Frame in Charcoal-stained ash. Tessuto / Fabric Arcipelago Hydra - B.



Brass 96

Gray 22

Gray 38



Kira 98

Gray 03

Brise 44

Brise 43

↓ Gray 09: Dondolo / Rocking chair. Struttura in frassino tinto Charcoal/ Frame in Charcoal-stained ash. Seduta/ Seat in Mountains Latemar - C.

Cuscini/ Cushions: 65x50 in Tweed Barley - D; 65x80 in Mountains Latemar - C.



Gray 09



Kira 98

Gray 03

↓ Gray 03: Divano/ Sofa. Struttura in frassino tinto Charcoal./ Frame in Charcoal-stained ash. Seduta/ seat in Tweed Barley - D.

Cuscini/ Cushions: 115x50 in Cosmo Urano - C, Mountains Latemar - C, Tweed Barley - D; 65x50 in Tweed Rye - D.

↓ Gray 42: Tavolino / Side table. Willow finish.

↓ Club 12: Divano/ Sofa in Soil Sandy - E. Loose cushion: 1 C. Club XS in Sand Zingaro - C.

↓ Gray 44: Tavolino / Side table. Burgundy finish.
↓ Gray 46: Tavolino / Side table. Willow finish.



Gray 42

Club 12

Gray 44

Gray 46



Gray 42

Gray 44



Tapies 69

↑ Tapies 96: Madia/
Sideboard, Basalt finish

↓ Gray 34: Tavolo rettangolare allungabile/ Extendable rectangular table. Piano in frassino tinto Charcoal.

Gambe in fusione di alluminio lucidato./ Charcoal-stained ash top. Legs in cast polished aluminum.



Gray 26

Gray 34

Gray 23

Kira 97



Gray 34

Gray 23

↓ Gray 26: Poltroncina/
Armchair. Struttura in frassino
tinto Charcoal / Frame in
Charcoal-stained ash. Tessuto/
fabric Corduroy Manhattan - C.

→ Tapies 69: Madia/
Sideboard, Gypsum finish.

→ Gray 23: Sedia/ Chair.
Struttura in frassino tinto
Larch./ Frame in Larch-
stained ash.



Light Geometry



↓ Gray 07: Poltrona/ Armchair.
Struttura in frassino tinto
Burgundy./ Frame in Burgundy-
stained ash. Seduta/ Seat in
Terre de Lin Vesta - B.

Cuscini/ Cushions: 65x50 in
Terre de Lin Vesta - B, Terre
de Lin Drakkar - B; 50x50 in
Corduoy Scoop - C.

Spin M, L

Club configuration 05

Brise 54, 56

Gray 07

→ Club configuration 05: Divano modulare/ Modular sofa in Lake View Erba - B. Loose cushions: 4 C. Club XS in Lake View Este - B, Stone Umber - C.

↙ Tapies 86: Credenza/ Highboard, Clay finish.



052



053

Light Geometry



↑ Gray 03: Divano/ Sofa.
Struttura in frassino tinto
Charcoal / Frame in Charcoal-
stained ash. Seduta /
Seat in Deus Atena - C.

Cushions: 115x50 in Deus Atena
- C, Deus Pegaso - C; 65x50 in
Mountains Cervino - C.

↑ Gray 42: Tavolino /
Side table. Ashbark, Charcoal.
Birch finish.

↑ Gray 44: Tavolino /
Side table. Ashbark finish.

→ Gray 01: Poltrona/ Armchair.
Struttura in frassino tinto Willow
/ Frame in Willow-stained ash.
Seduta / Seat in Sand Zingaro - C.
Cushions: 115x50 in Sand Bianca
- C, Tweed Barley - D; 65x50 in
Sand Zingaro - C.

→ Gray 41: Tavolino/ Side table,
Charcoal finish.



→ Gray 39: Tavolo/ Table.
Struttura in frassino tinto Larch
/ Frame in Larch-stained ash.

↓→ Santé 23: Sedia/ Chair.
Struttura in rattan tinto
Charcoal. Frame in Charcoal-
stained rattan.



058



059

Light Geometry



Croco 95

Gray 33

Ghost 23



← Ghost 23: Sedia/
Chair in Corduroy Annie Hall - C.

↑→ Gray 33: Tavolo rettangolare/
Rectangular table. Piano e gambe
in frassino tinto Sepia./ Top and legs
in Sepia-stained ash.

↓ Gray 07: Poltrona/ Armchair. Struttura in frassino tinto Burgundy./ Frame in Burgundy-stained ash. Seduta/ Seat in Terre de Lin Vesta - B. Cuscini/ Cushions: 65x50 in Terre de Lin Vesta - B, Terre de Lin Drakkar - B; 50x50 in Corduroy Scoop - C.

↓ Gray 42: Tavolino/ Side table. Ashbark, Willow finishes.

↓ Gray 44: Tavolino/ Side table. Birch finish.

↓ Club configuration 01: Divano modulare/ Modular sofa in Stone Buff - C. Loose cushions: 4 C. Club XS in Stone Mocha - C, Stone Alabaster - C.

↓ Gray 49: Tavolino/ Side table. Larch finish.





Club configuration 01

Gray 42, 44

Gray 49



Tapies 69



Silver 96

Club 133

Loll 224

Tapies 86

Loll 223

↑ Loll 223: Sedia/ Chair
in Tweel Leader - C.

↓→ Club 133: Tavolo rettangolare/ Rectangular table. Gambe in frassino tinto Willow. Piano in vetro Ginger./ Legs in Willow-stained ash. Ginger glass top.

↓→ Loll 224: Poltroncina/ Armchair in Tweel Leader - C.



↓ Ghost 23: Sedia/
Chair in Sand Zingaro - C.

↓ Jorn 33: Tavolo rettangolare
in frassino tinto Ashbark./
Rectangular table in Ashbark-
stained ash.

↓ Ghost 25: Poltroncina/
Armchair in Sand Zingaro - C.



Spin M, L

Tapies 86

Ghost 25

Ghost 23

Jorn 33



Tapiés 86

↑ Tapiés 86: Credenza/
Highboard, Clay finish.



Jorn 33

↳ Tapies 69: Madia/
Sideboard, Storm finish.

Pajama 96

Kira 98

Tapies 69

Gray 24

Gray 38



← Gray 38: Tavolo rotondo/
Round table Ø 160 cm. Base in
Millgres bianco Carrara./ White Millgres
base. Carrara white marble top.



↓ Gray 24: Poltroncina/
Armchair. Struttura in frassino
tinto Chalkwood / Frame in
Chalkwood-stained ash.
Cushion: Cosmo Urano - C.

Gray 24

↓ Santé 23: Sedia/ Chair.
Struttura in rattan tinto
Charcoal. Frame in Charcoal
stained rattan.



Santé 23

Gray 38

Tapies 69



Gray 15

Gray 45

Strap 80



←↓ Strap 80: Letto. Struttura in frassino tinto Willow./ Bed. Frame in Willow-stained ash. Tessuto/ fabric in Tweed Rice - D, Zodiac Virgo - C.

←↓ Gray 45: Comodino/ Bedside table. Struttura in frassino tinto Willow / Frame in Willow-stained ash.

Strap 80

Gray 45





Gray 21

Gray 50



Gray 15

← Gray 21: Sedia/ Chair.
Struttura in frassino tinto Larch
/ Frame in Larch-stained ash.

← Gray 50: Scrittoio/ Writing desk.
Struttura in frassino tinto Willow /
Frame in Willow-stained ash.

↑ Gray 15: Panca/ Bench.
Struttura in frassino tinto
Willow/ Frame in Willow-
stained ash. Tessuto/ fabric
Galassia Sirio - D.

↓ Loll 80: Letto/ Bed in Sand
Pollara - C (stitching Perla).



Pier 52

Loll 225

Loll 80



↑→ Pier 63: Cassettiera/
Chest of drawers. Struttura
in frassino tinto Larch / Frame
in Larch-stained ash.



Kira 98

Pier 63



Pier 60

Loll 225

← Loll 225: Sedia/
Chair in Cosmo Venere - C.

←↓ Pier 60: Scrivania / Writing
desk. Struttura in frassino tinto
Larch / Frame in Larch-stained
ash.





Pier 52

↑→ Pier 52: Comodino/
Bedside table. Struttura in
frassino tinto Larch / Frame
in Larch-stained ash.



Architectural Living



↓ Club configuration 04:
Divano modulare/ modular
sofa in Tweed Rice - D.
Loose cushions: 5 C. Club XS
in Soil Sandy - E, Soil Peaty - E,
Stone Gypsum - C.

↓ Tapies 85: Credenza/
Highboard, Dune finish.



Tapies 85

Medley 42

Club configuration 04

Medley 40



Tapies 85

Club configuration 04

Medley 40

098



099

Architectural Living

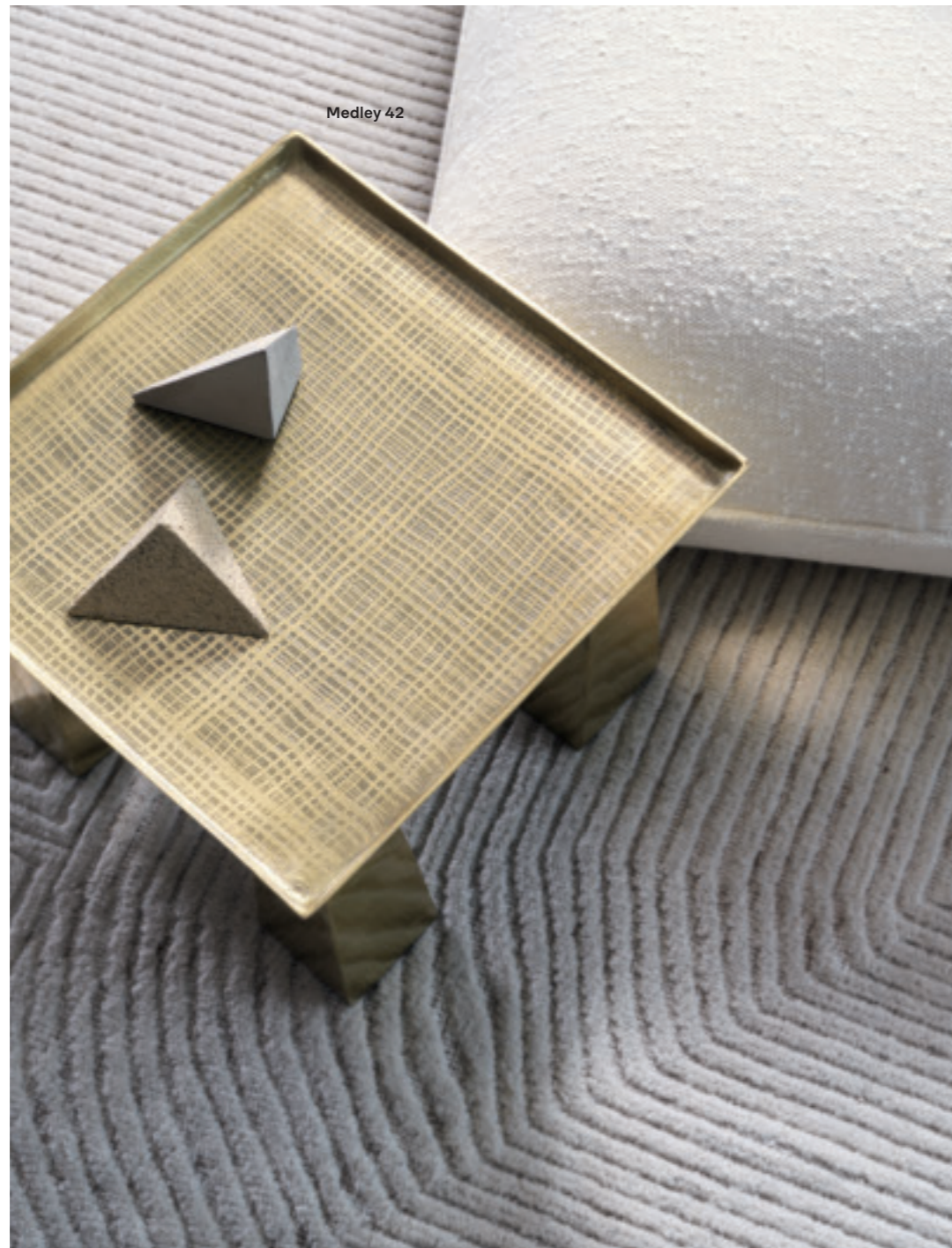

Medley 42



Medley 48



Tapie 68

Gray 07

Gray 42

Gray 42

↑ Gray 07: Poltrona/ Armchair.
Struttura in frassino tinto Sepia./
Frame in Sepia-stained ash.
Seduta/ seat in Sand Zingaro - C.

Cushions: 65x50 in Sand
Zingaro - C, 50x50 in
Mountains Ortles - C.

↑ Gray 42: Tavolino /
Side table. Sepia finish.

↓ Gray 34: Tavolo rettangolare/
Rectangular table. Piano in
frassino tinto Chalkwood. Gambe
in ceramica bianca./ Chalkwood-
stained ash top. White ceramic legs.

↓ Gray 22: Sedia/ Chair.
Struttura in frassino tinto
Chalkwood./ Frame in
Chalkwood-stained ash.
Tessuto/ fabric Tweed Rice - D.





Medley 95



Medley 42

Gray 29



Medley 42

← Gray 29: Dondolo/ Rocking chair.
Struttura in frassino tinto Burgundy./
Frame in Burgundy-stained ash.
Cuscino/ cushion in Tweed Sunset -D.

↓ Tapies 68: Madia/
Sideboard, Basalt finish.



Club configuration 03

Medley 40

Inout 46 IN

Tapies 68

Inout 45 IN



↔ Club configuration 03: Divano modulare/ modular sofa in Soil Loamy - E. Loose cushions: 3 C. Club XS in Lake View Belvedere - B, Stone Sterling - C.





Loll 225

↑ Loll 225: Sedia/
Chair in Grande Bouclé
Calais - D.

Loll 226

Jorn 33

↑ Jorn 33: Tavolo rettangolare/
Rectangular table. Piano e gambe
in frassino tinto Charcoal./
Top and legs in Charcoal-stained
ash.

Tapies 68



↑→ Tapies 68: Madia/
Sideboard, Basalt finish.



Tapies 68

Loll 225

↓ Gray 33: Tavolo rettangolare/
Rectangular table. Piano in
marmo bianco Carrara. Gambe
in frassino tinto Ashbark./
Top in Carrara white marble.
Legs in Ashbark-stained ash.

Medley 96

Tapies 85

Gray 26

Gray 33



Tapias 85



Tapias 85

Gray 26

↑→ Tapias 85: Credenza/
Highboard, Dune finish.

→ Gray 26: Poltroncina /
Armchair. Struttura in frassino
tinto Ashbark / Frame in
Ashbark-stained ash. Tessuto /
Fabric Tweed Rye - D.



Club 224

Tapis 68

Club 133

Club 223



Club 224

Club 223

Club 133

↑ Club 133: Tavolo rettangolare/
Rectangular table.
Gambe in frassino tinto Birch.
Piano in vetro Ginger./ Legs in
Birch-stained ash. Ginger glass top.

↑ Club 224: Poltroncina / Armchair.
Struttura in frassino tinto Birch /
Frame in Birch-stained ash. Tessuto /
Fabric Movida Cadice – D.

↑ Club 223: Sedia / Chair. Struttura
in frassino tinto Birch / Frame in
Birch-stained ash. Tessuto / Fabric
Movida Cadice – D.



← Gray 15: Panca/ Bench. Struttura in frassino tinto Maple / Frame in Maple-stained ash. Tessuto / Fabric Terre de Lin Vesta - B.

↓← Gray 09: Dondolo/ Rocking chair. Struttura in frassino tinto Maple / Frame in Maple-stained ash.

Seduta/ Seat in Terre de Lin Vesta - B. Cuscini/ Cushions: 65x80 in Terre de Lin Vesta - B, 65x50 in Tweed Sunset - D.





↑ Gray 21: Sedia in frassino tinto Larch./ Chair in Larch-stained ash.

↑ Gray 34: Tavolo rettangolare/ Rectangular table. Piano in lamiera di ferro cerata. Gambe in frassino tinto Larch./ Top in waxed iron sheet. Legs in Larch-stained ash.



Technical Info

Tinte Ad Acqua / Water-Based Finishes / Teintes À L'eau / Wasserbasierte Beizen

I. Le nuove tinte ad acqua nascono da una ricerca orientata alla qualità estetica e alla sostenibilità del processo produttivo. Penetrano nel legno e negli intrecci in midollino e rattan senza coprirne la materia, lasciandone visibile la texture naturale e garantendo uniformità cromatica e resistenza superficiale.

Una scelta tecnica che rappresenta un'evoluzione del nostro modo di lavorare i materiali: non una finitura che copre, ma un trattamento che valorizza la materia, riducendo l'impatto ambientale e migliorando la salubrità del processo produttivo.

E. The new water-based finishes are the result of research focused on aesthetic quality and the sustainability of the production process. They penetrate the wood and the woven wicker and rattan without covering the material, leaving the natural texture visible while ensuring colour uniformity and surface resistance.

A technical choice that represents an evolution in our way of working with materials: not a finish that covers, but a treatment that enhances the material, reducing environmental impact and improving the healthiness of the production process.

F. Les nouvelles teintures à l'eau sont le résultat d'une recherche orientée vers la qualité esthétique et la durabilité du processus de production. Elles pénètrent le bois ainsi que les tressages en osier et en rotin sans en couvrir la matière, laissant visible la texture naturelle tout en garantissant uniformité chromatique et résistance de surface.

Un choix technique qui représente une évolution de notre manière de travailler les matériaux : non pas une finition qui couvre, mais un traitement qui valorise la matière, en réduisant l'impact environnemental et en améliorant la salubrité du processus de production.

D. Die neuen wasserbasierten Beizen sind das Ergebnis einer Forschung, die auf ästhetische Qualität und die Nachhaltigkeit des Produktionsprozesses ausgerichtet ist. Sie dringen in das Holz sowie in Geflechte aus Weide und Rattan ein, ohne das Material zu überdecken, lassen die natürliche Textur sichtbar und gewährleisten gleichzeitig Farbgleichmäßigkeit und Oberflächenbeständigkeit.

Eine technische Entscheidung, die eine Weiterentwicklung unserer Materialbearbeitung darstellt: keine deckende Oberfläche, sondern eine Behandlung, die das Material aufwertet, die Umweltbelastung reduziert und die Gesundheit des Produktionsprozesses verbessert.

Finiture Legno / Wood Finishes



Finiture Midollino / Wicker Finishes Bell, Bolla, Spin collections

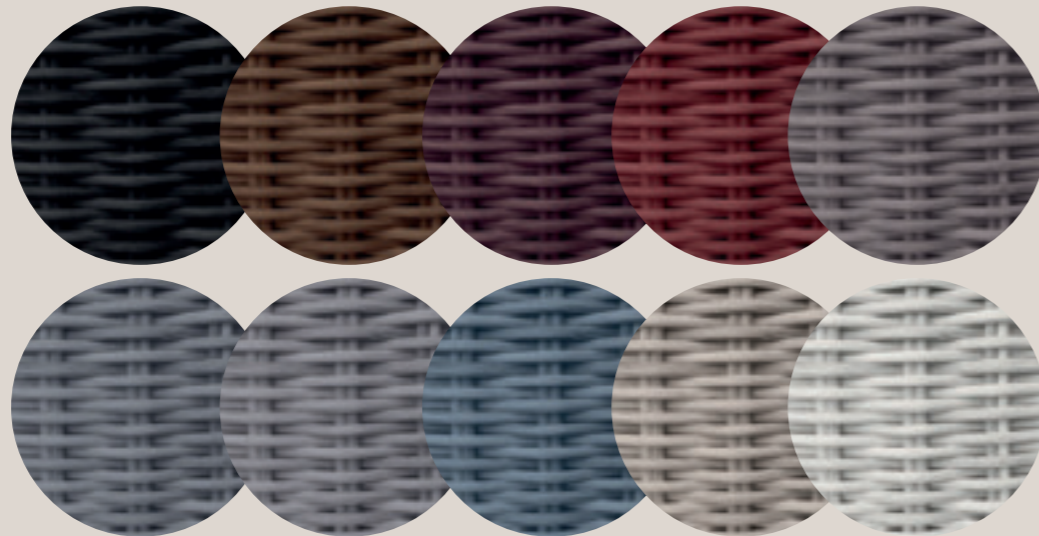

Gray

I. Animo vintage e design contemporaneo caratterizzano Gray, un'articolata collezione di sedie, poltrone, divani, tavoli e tavolini che mescola l'eleganza austera degli arredi classici alla semplicità delle forme nordiche. Una collezione in frassino impreziosito da lavorazioni e sagomature e da materiali inusuali come lamiera di ferro, ceramica, alluminio e marmo.

E. A vintage spirit and contemporary design define Gray, an articulated collection of chairs, armchairs, sofas, tables and coffee tables that blends the austere elegance of classic furniture with the simplicity of Nordic forms. A collection in ash wood enriched by craftsmanship, shaping and unusual materials such as iron sheet, ceramic, aluminium and marble.



Finiture Legno / Wood Finishes



Gray 01 → p. 057

Gray 03 → p. 036-037, 054-055

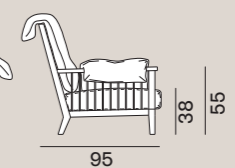
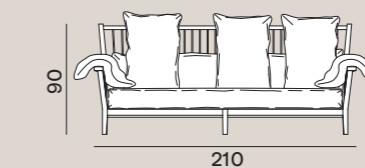
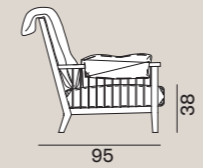
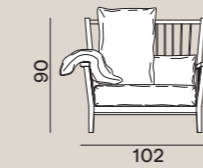

2
50x115

1
65x50

5
50x115

2
65x50

Gray 05 → p. 023

Gray 06 → p. 025

Gray 07 → p. 051, 062, 102-103

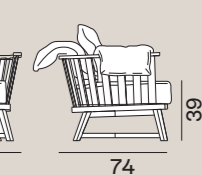
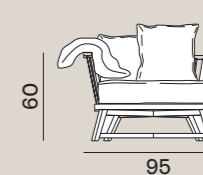
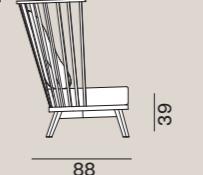
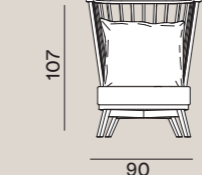
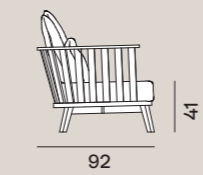
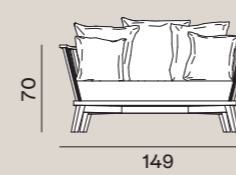

2
50x50

2
60x60

1
70x70

1
70x70

1
50x50

2
65x50

Gray 08 → p. 022

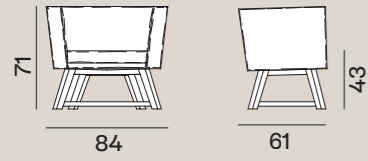

Gray 09 → p. 038, 126

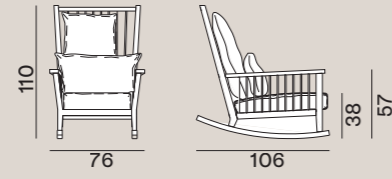

Gray 15 → p. 080-081, 126

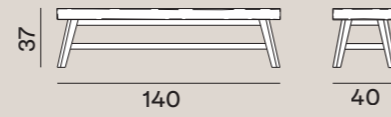

1
65x50 1
65x80

Gray 21 → p. 084, 128-129

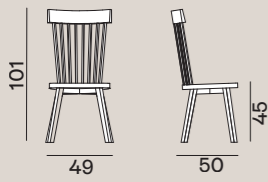

Gray 22 → p. 034, 035, 104-105

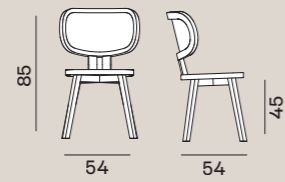

Gray 23 → p. 044, 047

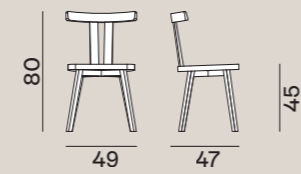

1
Optional

1
Optional

Gray 24 → p. 074-075, 077

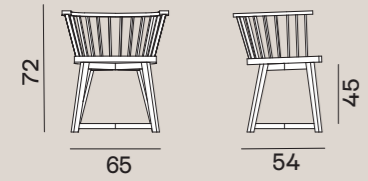

Gray 26/27 → p. 044, 046, 118-119, 121

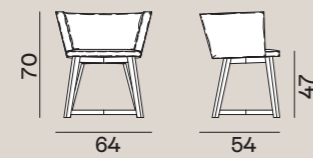

Gray 29 → p. 108

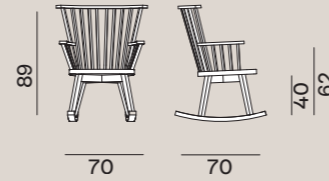

1
Optional

Gray 39 → p. 059

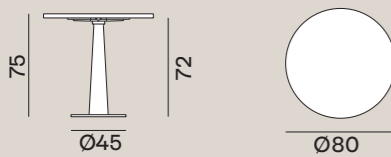

Gray 41 → p. 056

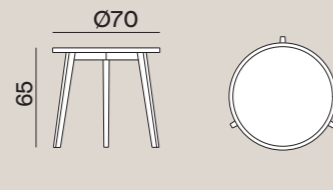

Gray 42 → p. 040, 042, 055, 062, 102

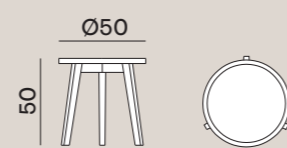

Gray 44 → p. 042, 055, 064

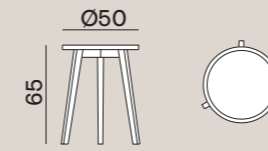

Gray 45 → p. 080-081, 083

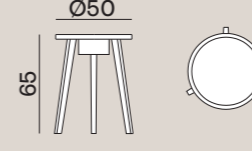

Con cassetto sottopiano
/ With drawer

Gray 49 → p. 062-063

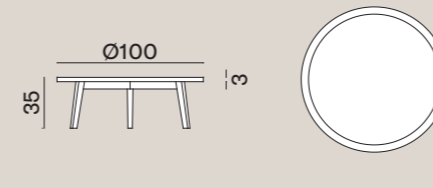

Piano massello
/ Solid top

C. Gray M

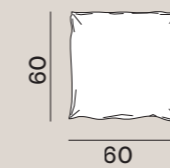

Gray 50 → p. 084

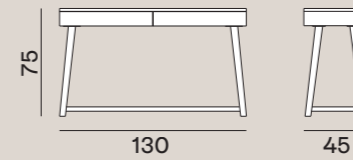

C. Gray L

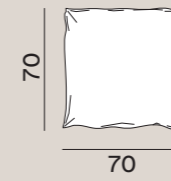

Gray 46 → p. 040-041

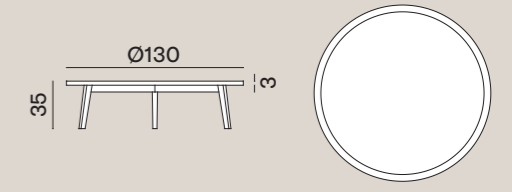

Piano massello
/ Solid top

C. Gray S

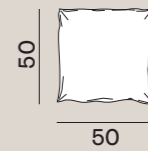

C. Gray GR

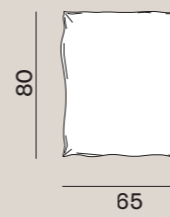

C. Gray XL

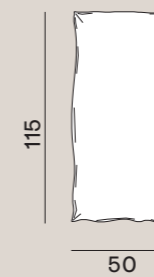

Finiture Piano / Top Finishes



Finiture Gambe/ Legs Finishes

Gray 32, 33, 34, 35

Gray 38

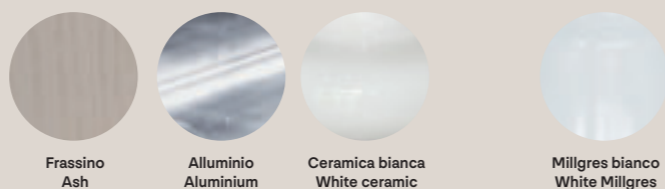

Finiture Legno / Wood Finishes



Gray 32 → p. 018-019

Gray 33 → p. 060-061, 118-119

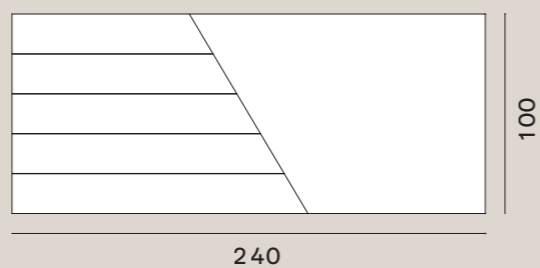
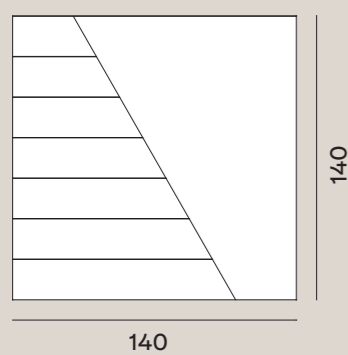
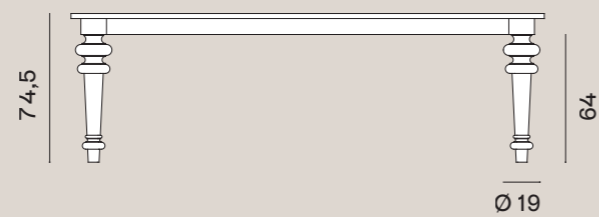
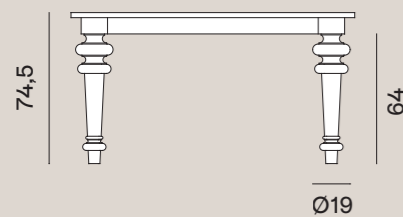

Legno doghe da 20 cm / 20 cm wooden slats

Legno doghe da 20 cm / 20 cm wooden slats

Gray 34 → p. 044, 045, 104-105, 128-129

Gray 35

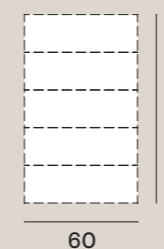
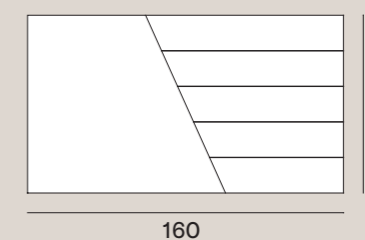
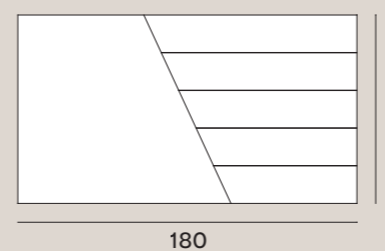
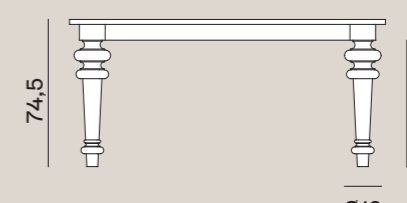
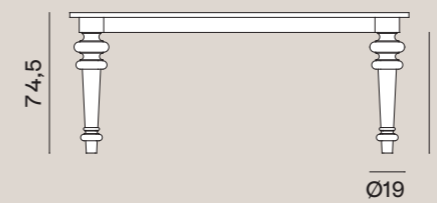

Legno doghe da 20 cm / 20 cm wooden slats

Legno doghe da 18 cm / 18 cm wooden slats

Gray 38 → p. 035, 074-075

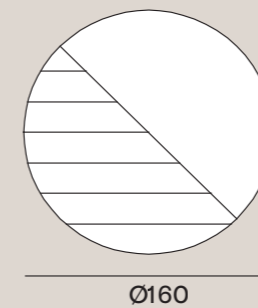
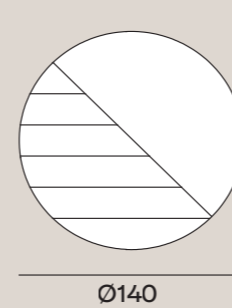
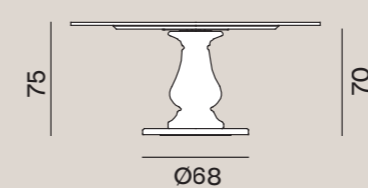

Legno doghe da 20 cm / 20 cm wooden slats

I. Segni essenziali e proporzioni equilibrate definiscono una collezione di arredi notte composta da scrittoio, cassetiera e comodino. La struttura in frassino con gambe inclinate a cavalletto disegna un segno leggero e riconoscibile, mentre le maniglie in corda introducono un dettaglio naturale che caratterizza la collezione. I cassetti sono dotati di sistema di chiusura ammortizzata.

E. Essential lines and balanced proportions define a bedroom furniture collection including a desk, chest of drawers and bedside table. The ash wood structure with inclined trestle legs creates a light and recognizable design, while the rope handles introduce a natural detail that characterises the collection. The drawers are equipped with a soft-closing system.



Finiture Legno / Wood Finishes



Pier 52 → p. 086-087, 092

Pier 60 → p. 087, 090

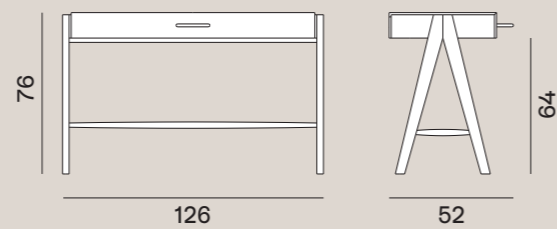
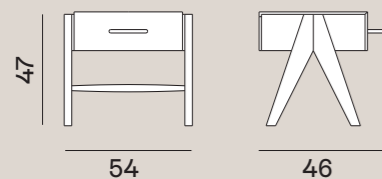

Pier 63 → p.088, 089

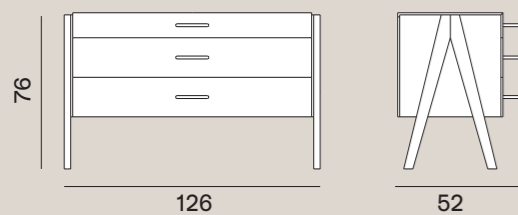

F. Des lignes essentielles et des proportions équilibrées définissent une collection de meubles pour la zone nuit composée d'un bureau, d'une commode et d'une table de chevet. La structure en frêne avec des pieds inclinés en tréteau dessine un signe léger et reconnaissable, tandis que les poignées en corde introduisent un détail naturel qui caractérise la collection. Les tiroirs sont dotés d'un système de fermeture amortie.

D. Klare Linien und ausgewogene Proportionen definieren eine Schlafzimmere Möbelkollektion bestehend aus Schreibtisch, Kommode und Nachttisch. Die Struktur aus Esche mit schräg gestellten Bockbeinen erzeugt ein leichtes und wiedererkennbares Erscheinungsbild, während die Griffe aus Seil ein natürliches Detail hinzufügen, das die Kollektion charakterisiert. Die Schubladen sind mit einem gedämpften Schließsystem ausgestattet.

I. Un disegno essenziale e proporzioni misurate definiscono il letto Strap, composto da una struttura in frassino e da un giroletto imbottito completamente sfoderabile e smontabile. La testiera è caratterizzata da un doppio rivestimento: un'imbottitura fissa e un cuscino sfoderabile, realizzabile anche in tessuto differente. Una cinghia in ecopelle avvolge la testiera e diventa il dettaglio distintivo del progetto.

E. An essential design and measured proportions define the Strap bed, composed of an ash wood structure and a padded bed frame that is completely removable and demountable. The headboard is characterised by double upholstery: fixed padding and a removable cushion that can also be made in a different fabric. An eco-leather strap wraps around the headboard, becoming the distinctive detail of the design.



Finiture Legno / Wood Finishes



Cucitura / Sewing / Couture / Naht

Interna / Internal / Intern / Intern

Fondo / Fastening / Finition / Ausführung

Velcrato / Velcro / Velcro / Klettverschluss

Strap 80 → p. 080-081, 082

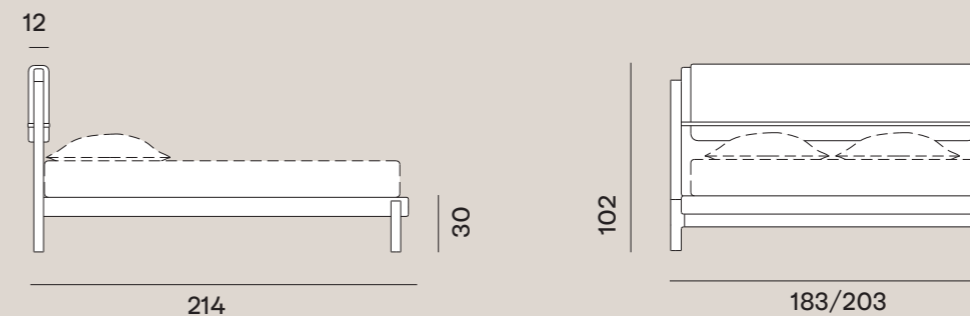

F. Un dessin essentiel et des proportions mesurées définissent le lit Strap, composé d'une structure en frêne et d'un cadre de lit rembourré entièrement déhoussable et démontable. La tête de lit est caractérisée par un double revêtement : un rembourrage fixe et un coussin déhoussable, également réalisable dans un tissu différent. Une sangle en éco-cuir enveloppe la tête de lit et devient le détail distinctif du projet.

D. Ein klares, essentielles Design und ausgewogene Proportionen definieren das Bett Strap, bestehend aus einer Struktur aus Esche und einem vollständig abziehbaren und zerlegbaren, gepolsterten Bettrahmen. Das Kopfteil ist durch eine doppelte Polsterung charakterisiert: eine feste Polsterung und ein abziehbares Kissen, das auch mit einem anderen Stoff bezogen werden kann. Ein Kunstlederriemen umschließt das Kopfteil und wird zum charakteristischen Detail des Bettes.

Tapies

Ready made by Concetta Giannangeli

I. Una superficie materica attraversata da sottili incisioni verticali definisce Tapies, collezione di madie e credenze dal carattere architettonico. La struttura in MDF è rifinita in cemento con effetto cannettato, disponibile in cinque colori, che restituisce una texture vibrante e contemporanea. I ripiani interni e le maniglie in vetro temperato trasparente aggiungono un dettaglio essenziale, creando un dialogo calibrato tra peso visivo e leggerezza.

E. A material surface marked by subtle vertical incisions defines Tapies, a collection of sideboards and cabinets with an architectural character. The MDF structure is finished in painted concrete with a fluted effect, available in five colours, creating a vibrant and contemporary texture. Internal shelves and handles in transparent tempered glass add an essential detail, balancing visual weight and lightness.



F. Une surface matérielle, traversée de fines incisions verticales, définit Tapies, une collection de buffets et de meubles de rangement au caractère architectural affirmé. La structure en MDF est finie en béton peint avec effet cannelé, disponible en cinq couleurs, créant une texture vibrante et contemporaine. Les étagères intérieures et les poignées en verre trempé transparent apportent une touche essentielle, créant un équilibre subtil entre poids visuel et légèreté.

D. Eine materielle Oberfläche mit feinen vertikalen Einschnitten definiert Tapies, eine Kollektion von Side- und Highboards mit architektonischem Charakter. Der MDF-Korpus ist mit Beton in geriffelter Optik beschichtet, erhältlich in fünf Farben, der eine lebendige und zeitgemäße Textur erzeugt. Innenböden und Griffe aus transparentem Hartglas setzen ein klares Detail und schaffen ein ausgewogenes Verhältnis zwischen visueller Schwere und Leichtigkeit.

Finiture / Finishes



Tapies 68 → p. 102, 110, 114-115, 116

Tapies 69 → p. 009, 017, 043, 065, 075

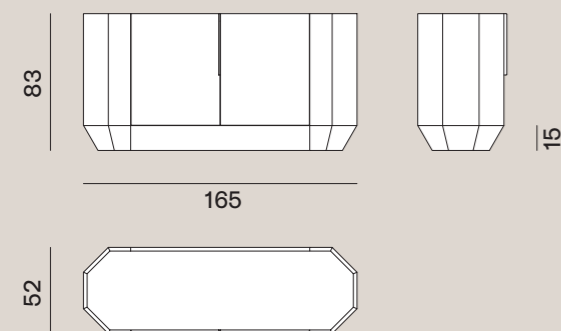

2 Ante / 2 Doors

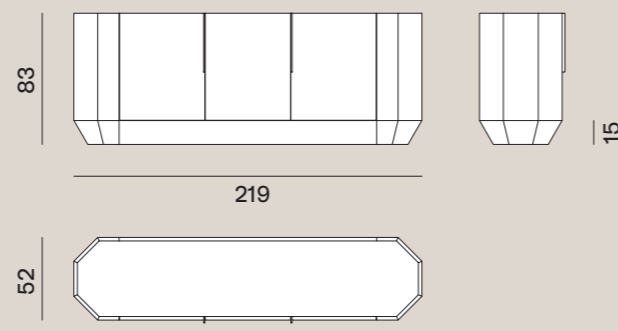

3 Ante / 3 Doors

Tapies

Ready made by Concetta Giannangeli

Tapies 85 → p. 096-097, 105, 118-119, 120, 121

Tapies 86 → p. 052, 067, 070, 073

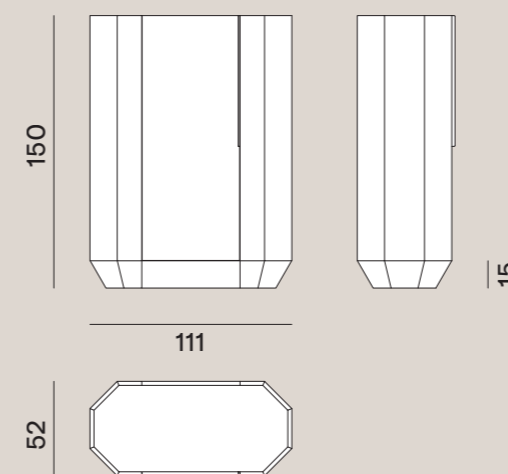

1 Anta / 1 Door

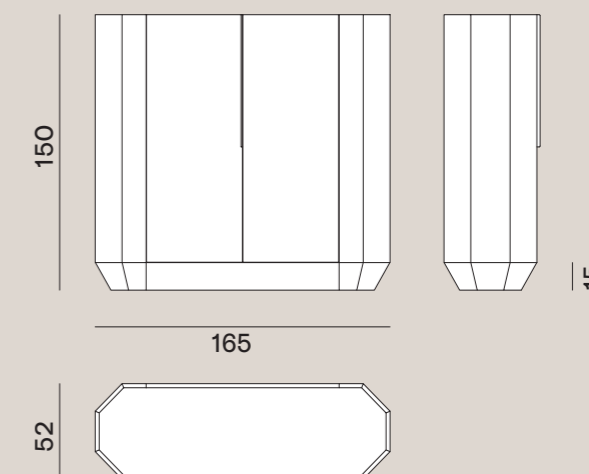

2 Ante / 2 Doors

I. Linee morbide e accoglienti definiscono Club, una collezione trasversale che si sviluppa tra area living e dining. I divani, fissi e componibili, sono pensati per offrire una sensazione di comfort avvolgente e informale. Il generoso e morbido schienale disegna una piega naturale che diventa il segno distintivo del progetto. L'imbottitura in poliuretano espanso garantisce sostegno e profondità di seduta, mentre il rivestimento completamente sfoderabile ne valorizza la praticità. I piedi in frassino tinto completano la composizione con un dettaglio materico.

E. Soft and welcoming lines define Club, a cross-sectional collection spanning living and dining areas. Fixed and modular sofas are designed to offer enveloping, informal comfort. The generous, soft backrest creates a natural fold that becomes the project's distinctive feature. Polyurethane foam padding ensures support and depth of seat, while the fully removable cover enhances practicality. Stained ash feet complete the composition with material detail.



F. Des lignes douces et accueillantes définissent Club, une collection transversale qui se développe entre espaces de vie et salle à manger. Les canapés, fixes et modulaires, sont conçus pour offrir un confort enveloppant et informel. Le dossier généreux et souple dessine un pli naturel qui devient le signe distinctif du projet. Le rembourrage en polyuréthane expansé assure soutien et profondeur d'assise, tandis que la housse entièrement déhoussable en souligne la praticité. Les pieds en frêne teinté complètent la composition avec un détail matériel.

D. Weiche und einladende Linien prägen Club, eine vielseitige Kollektion für Wohn- und Essbereiche. Klassische Sofas und modulare Elemente bieten ein umhüllendes, informelles Komfortgefühl. Die großzügige, weiche Rückenlehne bildet eine natürliche Falte, die zum charakteristischen Merkmal des Entwurfs wird. Die Polsterung aus Polyurethanschaum sorgt für Halt und Sitzkomfort, während die vollständig abnehmbare Husse die Funktionalität unterstreicht. Füße aus gebeizter Esche runden die Komposition mit einem materiellen Detail ab.

Struttura e materiali / Structure and materials

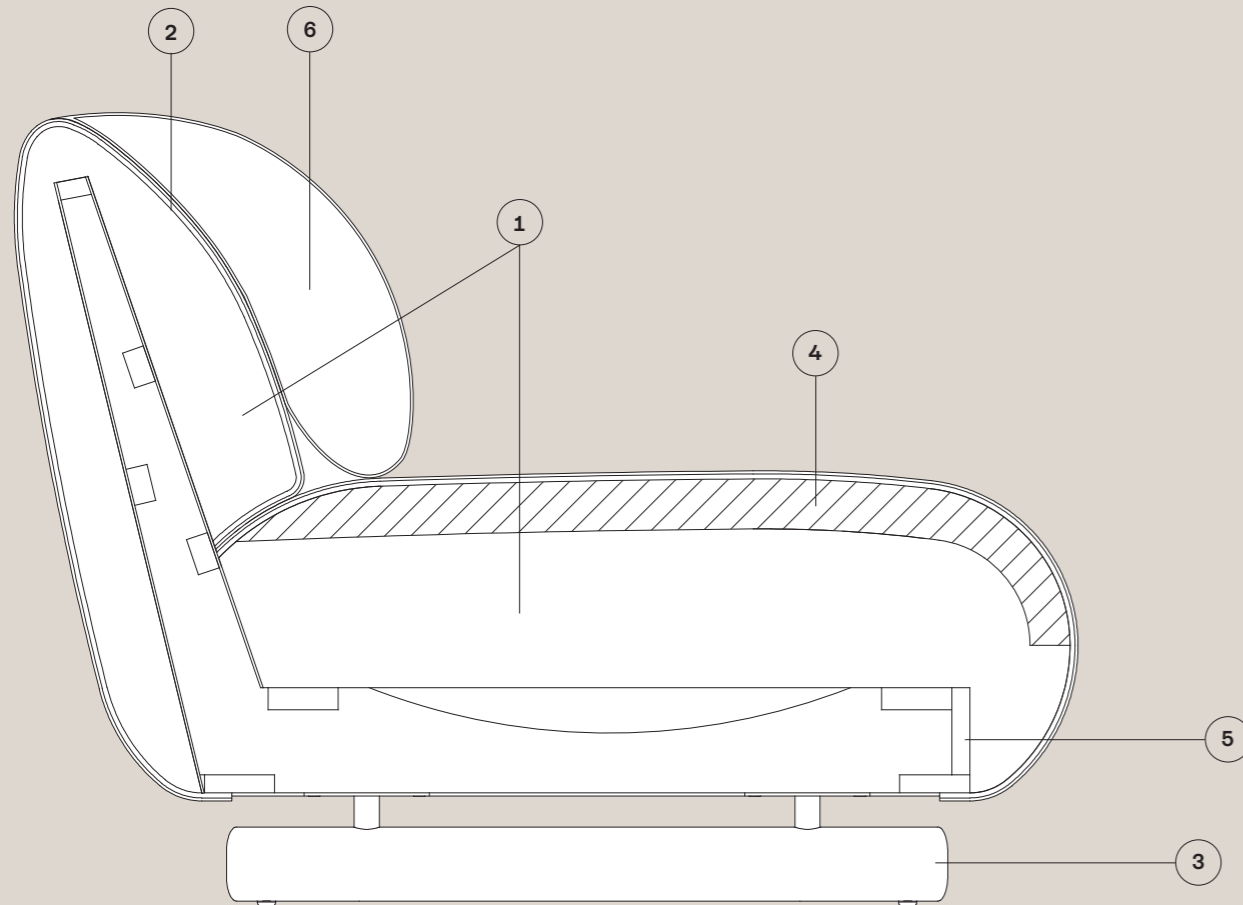

1. I. Poliuretano espanso ad alta densità con zone a portanza differenziata.
E. High-density polyurethane foam with differentiated support zones.
F. Mousse polyuréthane haute densité avec zones de soutien différenciées.
D. PU-Schaum mit hoher Dichte und differenzierten Stützzonen.

2. I. Rivestimento in fibra termolegata (resinato).
E. Structure covered with heat-bonded fiber (resin wadding).
F. Structure recouverte de fibre thermolée (ouate résinée).
D. Wattierung aus thermisch gebundener Faser.

3. I. Piede in legno di frassino.
E. Ash wood foot.
F. Pied en frêne.
D. Fuß aus Eschenholz.

4. I. Memory foam.
E. Memory foam.
F. Mousse à mémoire de forme.
D. Memory-Schaum.

5. I. Struttura in multistrato e abete.
E. Frame in plywood and fir wood.
F. Structure en contreplaqué et en bois de sapin.
D. Gestell aus Sperrholz und Fichtenholz.

6. I. Fibra
E. Fibre
F. Fibres
D. Faser

Club 10

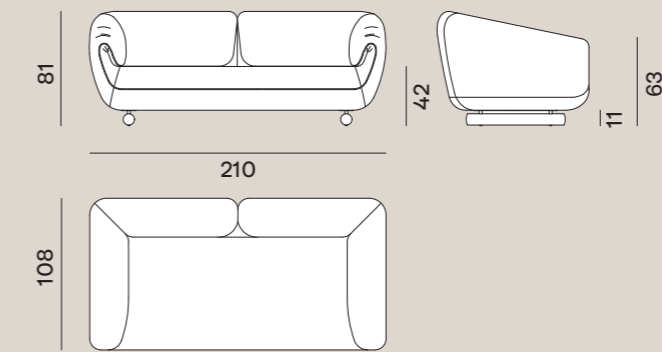

Club 12 → p.040-041

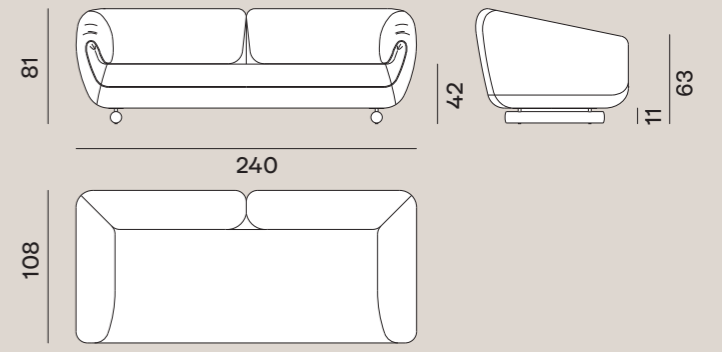

Club 14 → p. 012-013

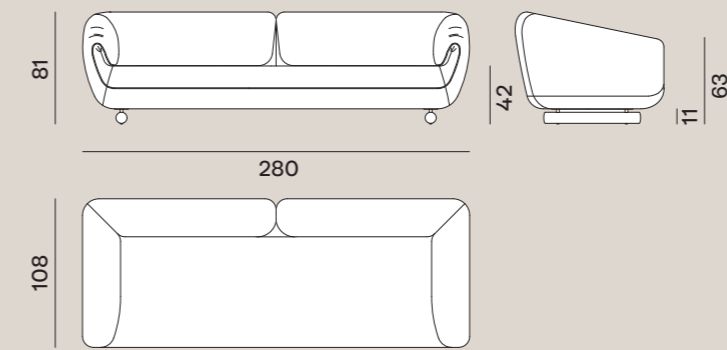

Club 20 L-R → p. 008-009

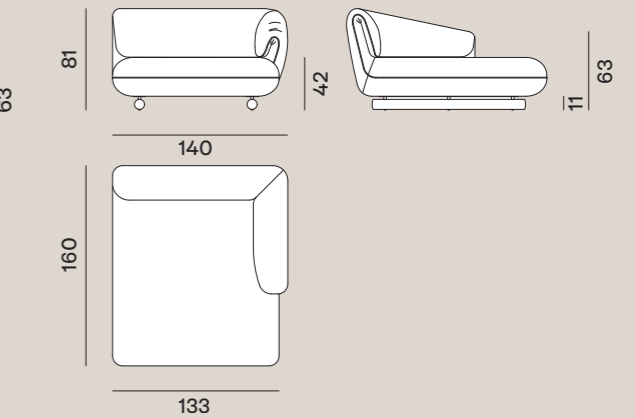

Club 21 L-R

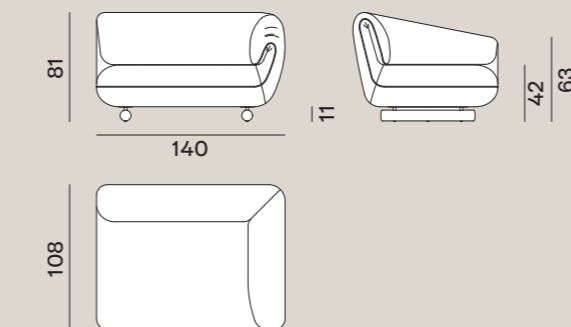

R

Club 23

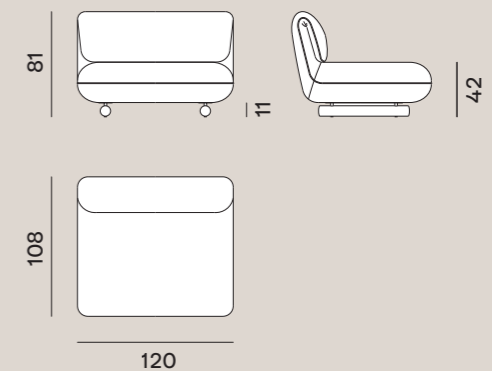

Club 25 L-R

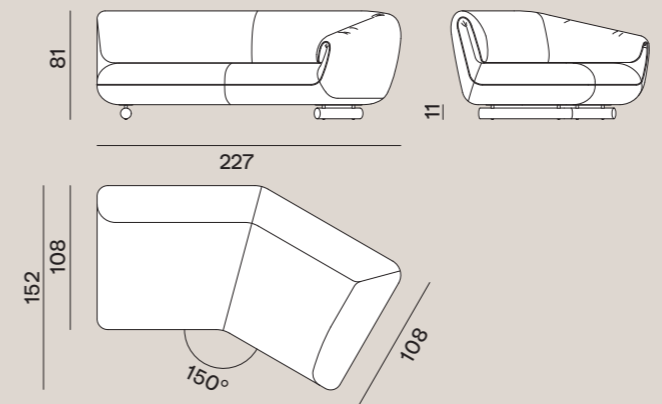

R

Club 26 L-R

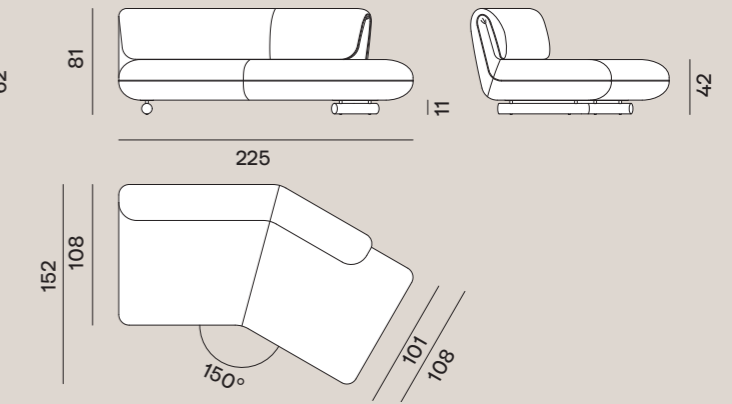

L

Club 27 L-R

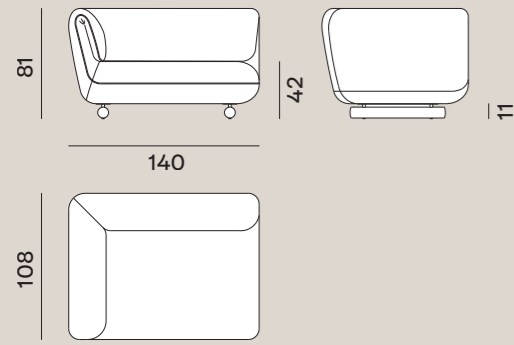

L Club 28

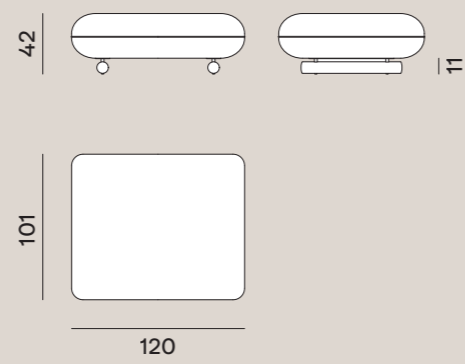

Club Configuration 01 → p. 062-063

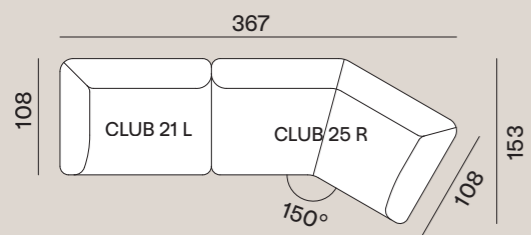

Club Configuration 02

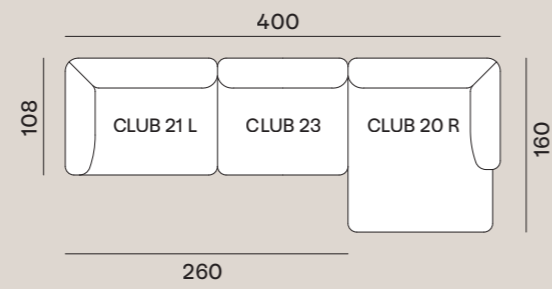

Club Configuration 03 → p. 110-111

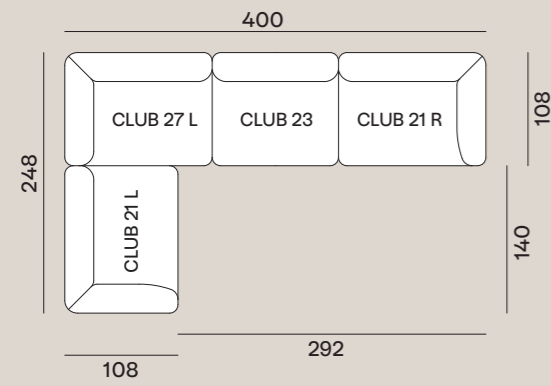

Club Configuration 04 → p. 096-097, 098

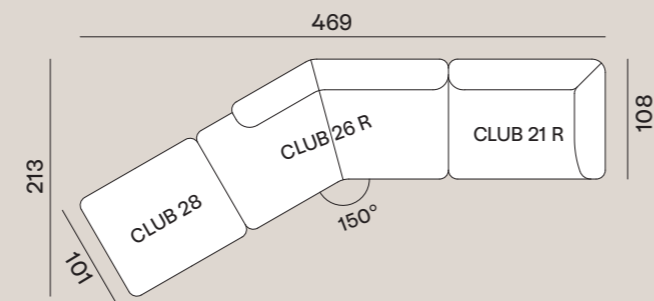

Club Configuration 05 → p. 050-051

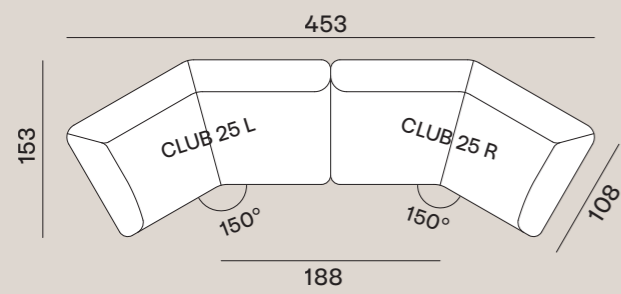

Club Configuration 06 → p.008-009

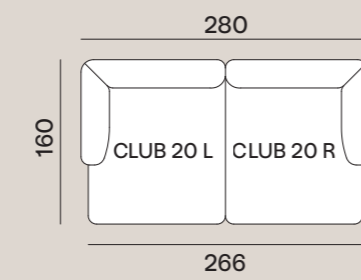

Club Configuration 07 → p. 032

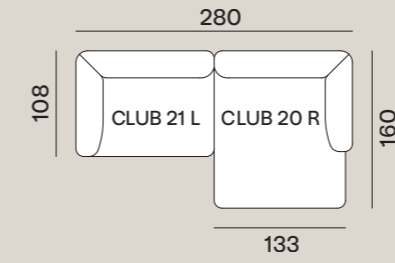

C. Club XS

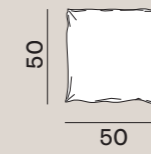

I. Nella zona dining, Club mantiene lo stesso linguaggio morbido e contemporaneo declinandolo in una collezione completa di tavoli e sedute. Il tavolo, disponibile rettangolare o quadrato, è composto da una struttura in frassino e da un piano con lati leggermente rientranti, realizzato in vetro retroverniciato oppure in gres Calacatta Oro. Sedia e poltroncina con braccioli, con struttura in frassino, sono completate da seduta e schienale imbottiti completamente sfoderabili.

E. In the dining area, Club maintains the same soft and contemporary language, expressed through a complete collection of tables and seating. The table, available in rectangular or square versions, features an ash wood structure and a top with slightly recessed edges, in back-painted glass or Calacatta Oro stoneware. Chair and armchair, with ash structure, feature padded seat and backrest with fully removable covers.

F. Dans l'espace dining, Club conserve le même langage doux et contemporain, décliné dans une collection complète de tables et d'assises. La table, disponible en version rectangulaire ou carrée, se compose d'une structure en frêne et d'un plateau aux bords légèrement rentrants, en verre rétro-laqué ou en grès Calacatta Oro. La chaise et le fauteuil, avec structure en frêne, sont dotés d'une assise et d'un dossier rembourrés entièrement déhoussables.

D. Im Essbereich bewahrt Club dieselbe weiche und zeitgemäße Formsprache und wird in einer vollständigen Kollektion von Tischen und Sitzmöbeln umgesetzt. Der Tisch ist in rechteckiger oder quadratischer Ausführung erhältlich und besteht aus einem Gestell aus Esche sowie einer Platte mit leicht zurückgesetzten Kanten aus rückseitig lackiertem Glas oder Calacatta Oro Feinsteinzeug. Stuhl und Armlehnstuhl mit Eschenstruktur verfügen über gepolsterte Sitz- und Rückenflächen mit vollständig abnehmbaren Bezügen.



Finiture Legno / Wood Finishes



Materiali Top / Top Materials



Club 132 → p. 026-027, 031

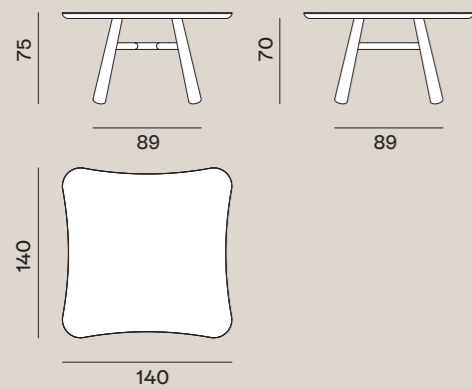

Club 133 → p. 066-067, 069, 122-123, 124

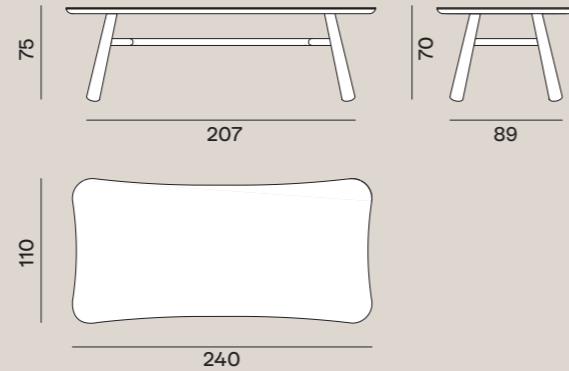

Club 134

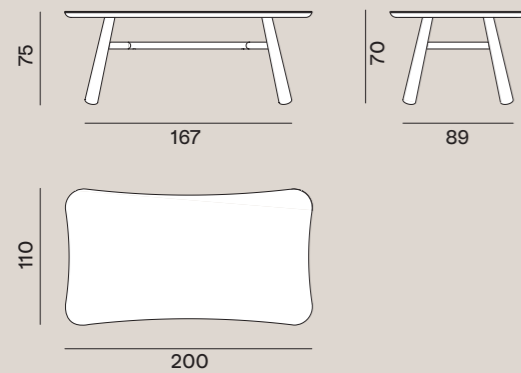

Finiture Legno / Wood Finishes



Club 223 → p. 026-027, 123, 124

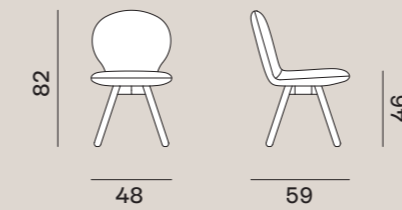

Club 224 → p. 031, 122, 124

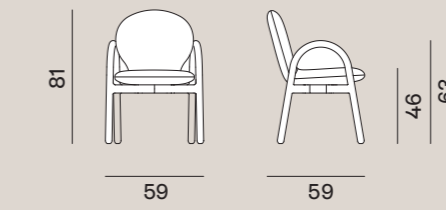

Jorn

I. Il tavolo rettangolare Jorn è caratterizzato da una base in frassino con gambe leggermente ruotate, che introducono un segno dinamico e distintivo. Il piano, impiallacciato con bordo in massello, è definito da un profilo sagomato con rastrematura, che genera una variazione percettiva capace di alleggerire il volume e valorizzarne la costruzione artigianale.

E. The rectangular Jorn table is defined by an ash wood base with gently rotated legs, introducing a dynamic and distinctive visual rhythm. The veneered top, finished with a solid wood edge, features a shaped and tapered profile that lightens the overall volume and emphasises the craftsmanship of its construction.

F. La table rectangulaire Jorn se caractérise par une base en frêne avec des pieds légèrement orientés, introduisant un signe dynamique et distinctif. Le plateau, plaqué avec bord en bois massif, présente un profil façonné avec une légère conicité, générant une variation perceptive qui allège le volume et valorise sa fabrication artisanale.

D. Der rechteckige Tisch Jorn zeichnet sich durch ein Gestell aus Esche mit leicht gedrehten Beinen aus, die eine dynamische und markante Wirkung erzeugen. Die furnierte Tischplatte mit Massivholzkante besitzt ein geformtes Profil mit Verjüngung, das eine visuelle Leichtigkeit schafft und die handwerkliche Ausführung hervorhebt.



Finiture Legno / Wood Finishes



Jorn 33 → p. 070-071, 073, 114-115, 117

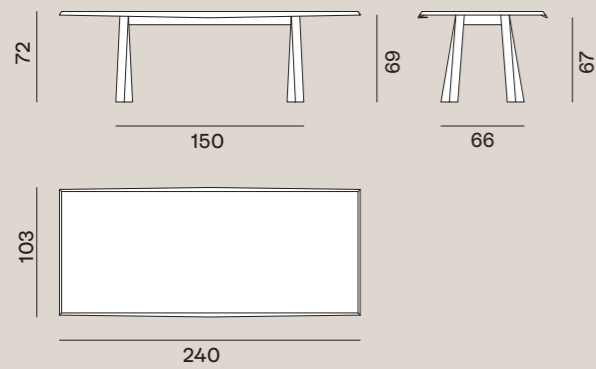

Jorn 34

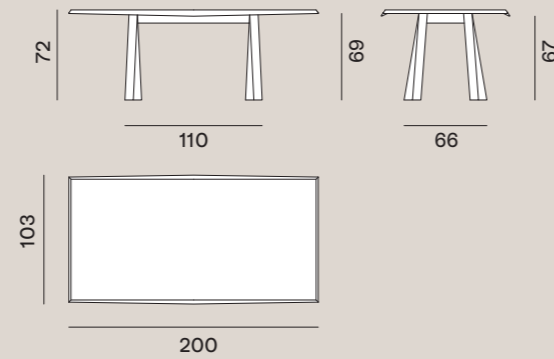

Medley

I. Collezione trasversale che unisce elementi decorativi e arredi attraverso un linguaggio materico e coerente. Le lampade a sospensione, coniche, sono realizzate in filo di acciaio intrecciato con trattamento galvanico, disponibili in due finiture e dimensioni. I tavolini, in alluminio, combinano forme scultoree e superfici texturizzate e acidate, espressione di una raffinata lavorazione artigianale.

E. A cross-sectional collection that brings together decorative elements and furniture through a coherent, material-driven language. Conical suspension lamps are made of woven galvanised steel wire, available in two finishes and sizes. The coffee tables, in aluminium, combine sculptural forms with textured, acid-treated surfaces, expressing refined craftsmanship.



Finiture / Finishes Medley 42, 48, 95, 96



Finiture / Finishes Medley 40



Medley 40 → p. 096-097, 098, 110-111, 112

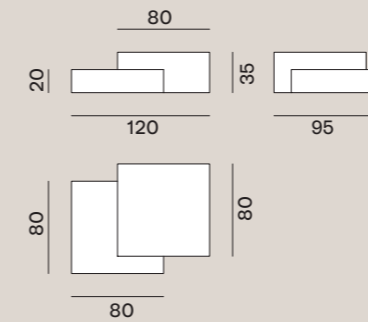

Medley 42 → p. 097, 100, 109

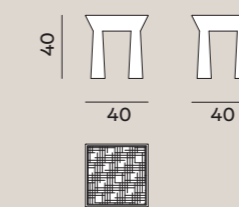

Medley 48 → p. 101

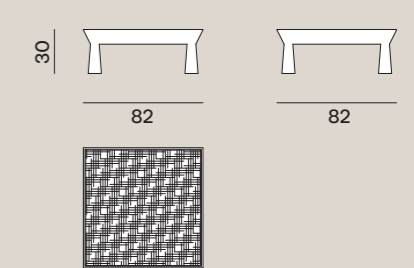

Medley 95 → p. 104-105, 107

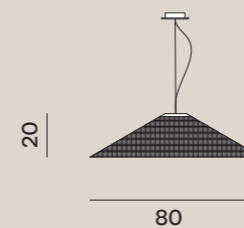

Medley 96 → 118-119, 128-129

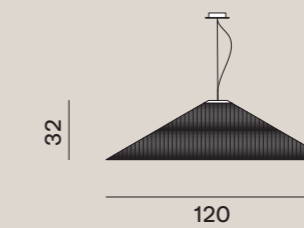

Ready made by Concetta Giannangeli

F. Une collection transversale qui réunit éléments décoratifs et mobilier à travers un langage cohérent et matériel. Les suspensions coniques sont réalisées en fil d'acier tressé avec traitement galvanique, disponibles en deux finitions et dimensions. Les tables basses, en aluminium, associent formes sculpturales et surfaces texturées et acidées, expression d'un savoir-faire artisanal raffiné.

D. Eine vielseitige Kollektion, die dekorative Elemente und Möbel durch eine kohärente, materialbetonte Sprache vereint. Die konischen Pendelleuchten bestehen aus geflochtenem, galvanisiertem Stahldraht und sind in zwei Ausführungen und Größen erhältlich. Die Beistelltische aus Aluminium verbinden skulpturale Formen mit strukturierten, säurebehandelten Oberflächen und stehen für eine anspruchsvolle handwerkliche Verarbeitung.

I. La poltrona R 513, progetto originale di Vico Magistretti per Gervasoni negli anni Ottanta, viene rieditata in collaborazione con la Fondazione Vico Magistretti e torna in produzione con il linguaggio senza tempo che la definisce. Realizzata in rattan Manau, si costruisce attraverso una sequenza di elementi verticali raccordati da una linea continua che integra schienale e braccioli in un unico gesto. L'equilibrio tra pieni e vuoti genera un volume leggero ma definito, in cui la precisione costruttiva restituisce intatta la logica originale del progetto.

E. The R 513 armchair, originally designed by Vico Magistretti for Gervasoni in the 1980s, is reissued in collaboration with the Vico Magistretti Foundation and returns to production with the timeless language that defines it. Crafted in Manau rattan, it is constructed through a sequence of vertical elements connected by a continuous line that seamlessly integrates backrest and armrests into a single gesture. The balance between solids and voids creates a light yet defined volume, where precise craftsmanship preserves the original logic of the design.

F. Le fauteuil R 513, projet original de Vico Magistretti pour Gervasoni dans les années 1980, est réédité en collaboration avec la Fondation Vico Magistretti et revient en production avec le langage intemporel qui le définit. Réalisé en rotin Manau, il se construit à travers une séquence d'éléments verticaux reliés par une ligne continue qui intègre dossier et accoudoirs en un seul geste. L'équilibre entre pleins et vides génère un volume léger mais défini, où la précision constructive restitue intacte la logique originale du projet.

D. Der Sessel R 513, ein Originalentwurf von Vico Magistretti für Gervasoni aus den 1980er Jahren, wird in Zusammenarbeit mit der Vico Magistretti Stiftung neu aufgelegt und kehrt mit der zeitlosen Formensprache, die ihn auszeichnet, in die Produktion zurück. Gefertigt aus Manau-Rattan, entsteht er aus einer Abfolge vertikaler Elemente, die durch eine durchgehende Linie verbunden sind, welche Rückenlehne und Armlehnen in einer einzigen Geste vereint. Das Gleichgewicht zwischen offenen und geschlossenen Flächen erzeugt ein leichtes, aber klar definiertes Volumen, in dem die konstruktive Präzision die ursprüngliche Logik des Entwurfs bewahrt.



Finiture / Finishes



Rattan manau
naturale
Natural manau
rattan

R 513 p → p. 011

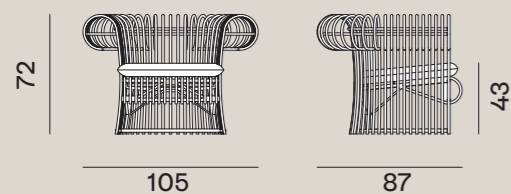

I. Santé reinterpreta la tradizione delle sedute bistrot in chiave contemporanea. Realizzata in rattan curvato e intrecciato, la struttura esprime una lavorazione artigianale che si traduce in una sequenza ritmica di archi e raccordi, disegnando uno schienale leggero e avvolgente. Disponibile in 10 finiture.

E. Santé reinterprets the tradition of bistro seating in a contemporary way. Made of bent and woven rattan, the structure expresses craftsmanship through a rhythmic sequence of curves and joints, creating a light and enveloping backrest. Available in 10 finishes.

F. Santé réinterprète la tradition des sièges bistrot dans une clé contemporaine. Réalisée en rotin cintré et tressé, la structure exprime un savoir-faire artisanal à travers une séquence rythmée d'arcs et de raccords, dessinant un dossier léger et enveloppant. Disponible en 10 finitions.

D. Santé interprétiert die Tradition der Bistrostühle in zeitgemäßer Form neu. Gefertigt aus gebogenem und geflochtenem Rattan, zeigt die Struktur handwerkliche Qualität in einer rhythmischen Abfolge von Bögen und Verbindungen, die eine leichte und umhüllende Rückenlehne formen. Erhältlich in 10 Ausführungen.



Finiture Rattan / Rattan Finishes



Santé 23 → p. 058, 059, 078-079

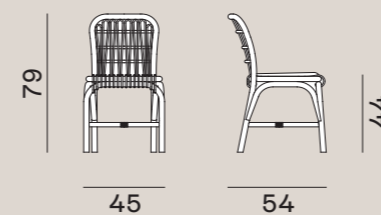



Abacus by Categories

Armchairs

Gray 01 → p. 057



Gray 06 → p. 025



Gray 07 → p. 051, 062, 102-103



Gray 24 → p. 074-075, 077



Gray 26 → p. 044, 046, 118-119, 121



Loll 223 → p. 018-019, 067



Loll 224 → p. 067, 069



Gray 08 → p. 022



Gray 09 → p. 038, 126



Gray 29 → p. 108



Loll 09 → p. 033



Loll 225 → p. 087, 114-115



Santé 23 → p. 058, 059, 078-079



R 513 p → p. 011



Sofas

Club 12 → p. 040-041



Club 14 → p. 012-013

Chairs

Club 223 → p. 026-027, 123, 124



Club 224 → p. 031, 122, 124



Ghost 23 → p. 060-061, 070



Club Configurations → p. 008, 032, 050, 062, 096, 110



Gray 03 → p. 036-037, 054-055



Ghost 25 → p. 071



Gray 21 → p. 84, 128-129



Gray 22 → p. 034, 035, 104-105



Gray 23 → p. 044, 047



Gray 05 → p. 023



Tables & Desks

Gray 32 → p. 018-019



Gray 33 → p. 060-061, 118-119

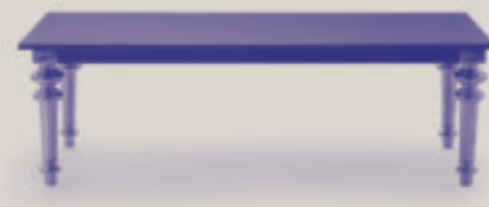

Gray 34 → p. 044, 045, 104-105, 128-129

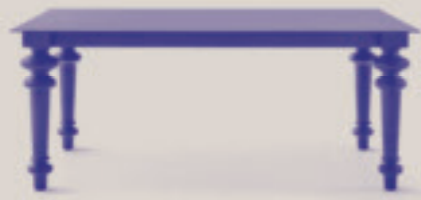

Gray 38 → p. 035, 074-075



Gray 39 → p. 059



Jorn 33 → p. 070-071, 073, 114-115, 117



Club 132 → p. 026-027, 031



Club 133 → p. 066-067, 069, 122-123, 124



Gray 50 → p. 084

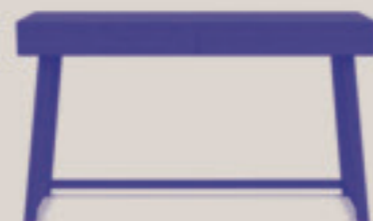

Pier 60 → p. 087, 090



Coffee Tables & Night tables

Gray 41 → p. 056



Gray 42 → p. 040, 042, 055, 062, 102



Gray 44 → p. 042, 055, 064



Gray 45 → p. 080-081, 083



Gray 46 → p. 040-041



Gray 49 → p. 062-063



Pier 52 → p. 086-087, 092



Heiko 41, 42, 43, 44 → p. 012-013, 033



Brise 43, 44, 46 → p. 036



Brise 53, 54, 56 → p. 022-023, 051



Inout 45IN → p. 110-111



Inout 46IN → p. 110-111



Medley 40 → p. 096-097, 098, 110-111, 112



Medley 42 → p. 097, 100, 101, 109



Medley 48 → p. 097, 100, 101, 109



Beds

Strap 80 → p. 080-081, 082



Loll 80 → p. 086-087



Storage Units

Pier 63 → p. 088, 089



Tapies 68 → p. 102, 110, 114-115, 116



Tapies 69 → p. 009, 017, 043, 065, 075



Tapies 85 → p. 096-097, 105, 118-119, 120, 121



Tapies 86 → p. 052, 067, 070, 073



Complements

Gray 15 → p. 080-081, 126



Kira 97 → p. 009, 045



Kira 98 → p. 011, 036, 089, 126



Lightings

Spin S,M → p. 050, 070



Bolla S,M, L → p. 054, 055



Brass/Silver 95 → p. 026



Brass/Silver 96 → p. 035, 066



Medley 95 → p. 104-105, 107

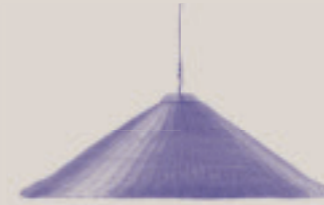

Medley 96 → p. 118-119, 128-129

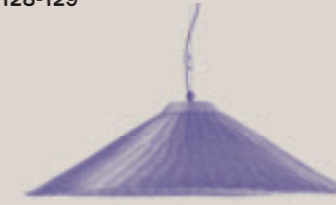

Croco 95 → p. 060-061



Pajama 96 → p. 074-075



Rugs

Next 999 → p. 066, 078, 080, 087, 128



Credits

Graphic Design:
Choice–Studio

Product design:
René Barba
Federica Biasi
Oscar & Gabriele Buratti
Marta Giardini
Roberto Lazzeroni
Vico Magistretti
Paola Navone
Neri&Hu
David Lopez Quincoces
Michael Sodeau

Ready made collections
by Concetta Giannangeli

Photo:
Max Rommel

Styling:
Ilaria Baccocchi Studio

Colour separation:
Lucegroup.it

Printed in Italy:
Grafiche Antiga
April 2026

Gervasoni Spa
Viale del Lavoro, 88
33050 Pavia di Udine, Italy
ph. +39 0432 656611
info@gervasoni1882.com
www.gervasoni1882.com

Thanks to:

Alberto Levi Gallery
albertolevi.com

GT Design
gtdesign.it

Karpeta
karpeta.it

KDLN
kdln.it

Luceplan
luceplan.com

Mohebban
mohebbanmilano.com

Nume
numedesign.it

Restart Milano
restartmilano.com

Servomuto
servomuto.it

TOOY Lighting
tooy.it

GERVASONI®

1882

Gervasoni spa è dotata di un Sistema di Qualità Certificato UNI EN ISO 9001, di un Sistema per la gestione della Sicurezza e della Salute dei lavoratori Certificato ISO 45001 e di un Sistema di Gestione Ambientale Certificato UNI EN ISO 14001 / Gervasoni spa is certified to: UNI EN ISO 9001 Company Quality System Certification, ISO 45001 Certification for Health and Safety Management Systems and UNI EN ISO 14001 Environmental Management System Certification.



PART OF

DEXELANCE



CATGRAY26

© Copyright 2026 Gervasoni S.p.A.
Tutti i diritti riservati

