

SPAM

IL PEZZO MANCANTE

2026

Tutti cerchiamo il nostro Pezzo Mancante

“ we are all looking for our Missing Piece ”



La nostra storia, *our story*

“Dal momento in cui ci siamo conosciuti nel 2007, abbiamo condiviso una grande passione per l’artigianalità, i materiali nobili e naturalmente, per il design. Nel 2010, spinti dal desiderio di dare vita alle nostre idee e forti del nostro legame (e anche grazie a un po’ di follia!), abbiamo fondato Il Pezzo Mancante, unendo le nostre competenze nell’illuminazione e nell’arredamento.

Nel tempo, Il Pezzo Mancante è diventato parte della nostra famiglia, qualcosa di cui prendersi cura. Abbiamo formato un team di persone appassionate che condividono i nostri stessi valori e la stessa follia.

Il Pezzo Mancante è un mondo che esalta la bellezza del pezzo fatto a mano, la trasformazione della materia grezza e la sperimentazione di nuove tecnologie unite alla più alta tradizione artigiana.

Le collezioni, create con grande cura nel nostro Atelier di Firenze, si trasformano in tesori senza tempo, diventando il “Pezzo Mancante” negli ambienti dei nostri clienti.”

“Since we met in 2007, we have shared a deep passion for craftsmanship, noble materials, and of course, design. In 2010, driven by the desire to bring our ideas to life and strengthened by our bond (and a little bit of madness!), we founded Il Pezzo Mancante, combining our expertise in lighting and furniture.

Over time, Il Pezzo Mancante has become part of our family, something to care for. We have built a team of passionate people who share our values and the same spark.

Il Pezzo Mancante is a world that celebrates the beauty of handcrafted pieces, the transformation of raw materials and the fusion of new technologies with the finest artisanal traditions.

The collections, meticulously crafted in our Florence Atelier, evolve into timeless treasures, becoming the “Missing Piece” in our clients’ spaces.”

COSIMO TERZANI + BARBARA BERTOCCI

At the final stage of assembling a huge custom Il Pezzo 3 Chandelier

L'unicità, *the uniqueness*

L'eccezionalità dei materiali naturali con le loro infinite variazioni e le imperfezioni della lavorazione artigianale, si uniscono per dar vita a oggetti irripetibili.

Per valorizzare questa unicità, ogni opera ha il proprio "Pezzo Mancante": un piccolo cilindro in ottone che ne riporta inciso il nome e il numero di serie.

Questo semplice oggetto è anche la rappresentazione del nostro concetto di "Pezzo Mancante": la metafora di una ricerca continua, quel "pezzo" che ciascuno di noi desidera trovare in un preciso momento della propria vita.

The exclusivity of natural materials, with their endless variations and the imperfections of artisanal craftsmanship, come together to create one-of-a-kind objects.

To highlight this uniqueness, each creation has its own "Missing Piece": a small brass cylinder engraved with its name and serial number.

This simple object also embodies our idea of the "Missing Piece": a metaphor for the ongoing search we all undertake, that "piece" we all wish to find at a special moment in our lives.

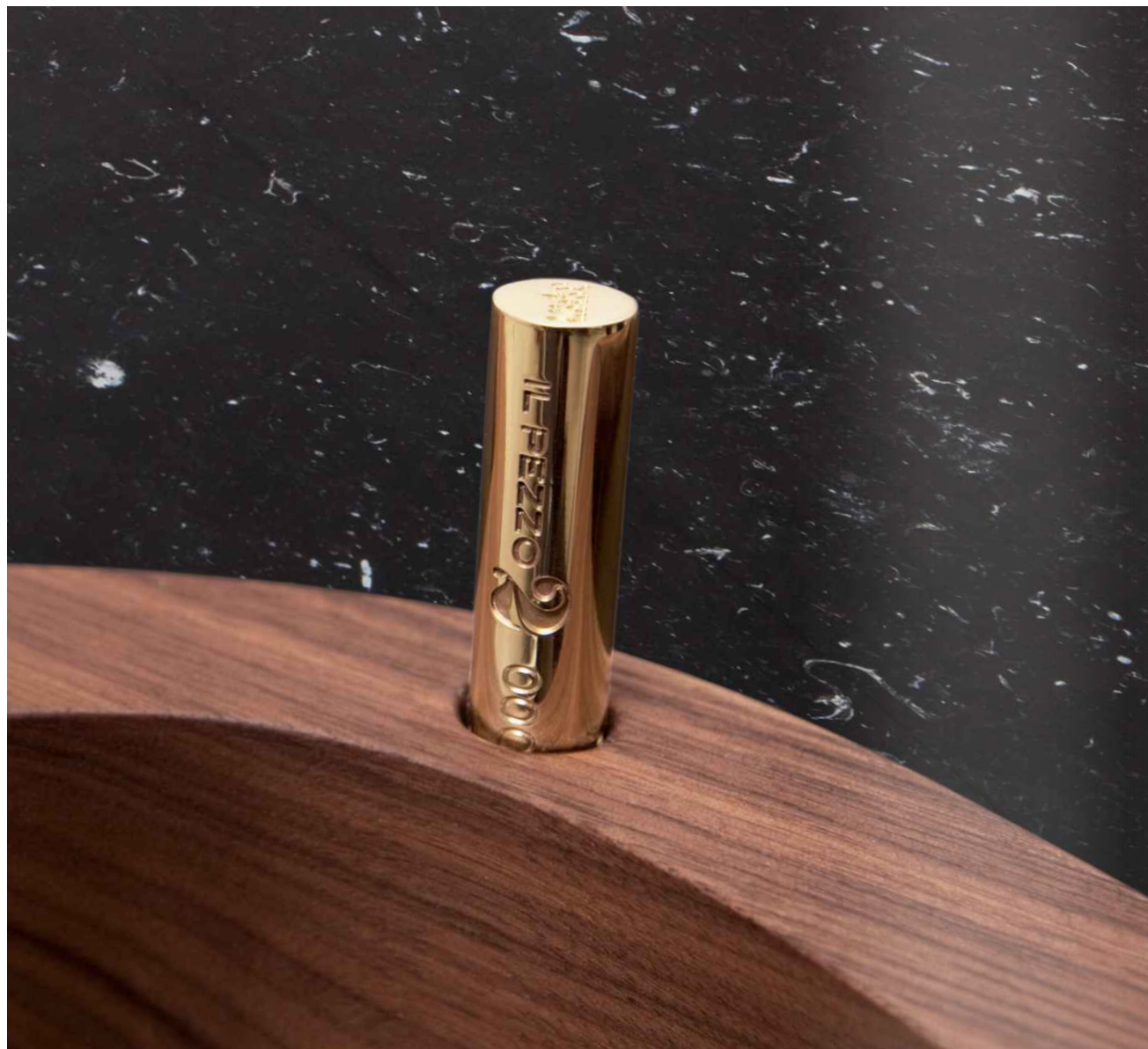

Scatti dall'atelier, *snapshots from the atelier*

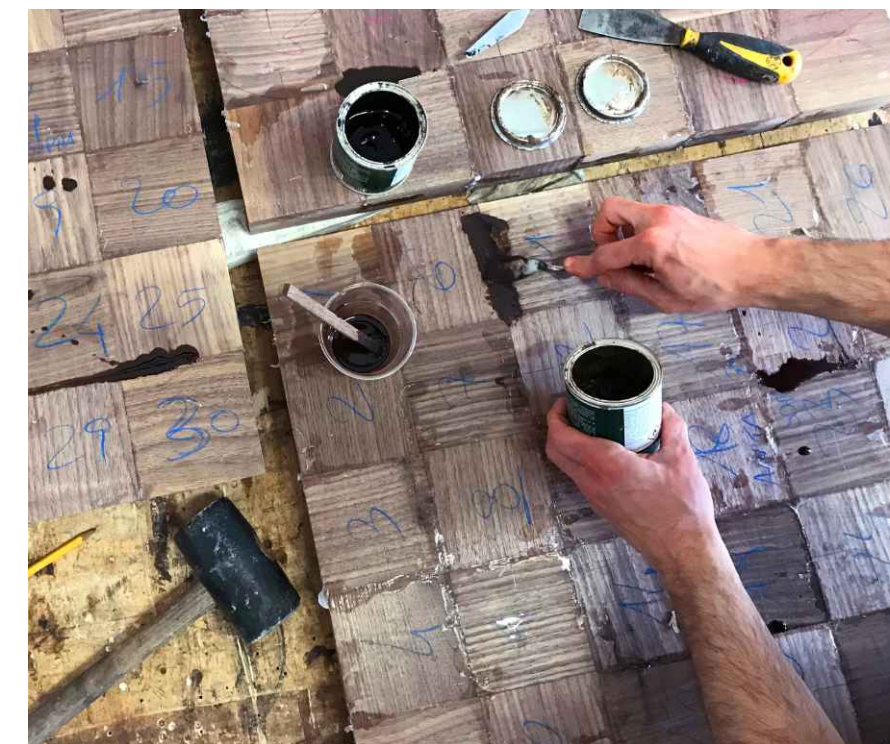

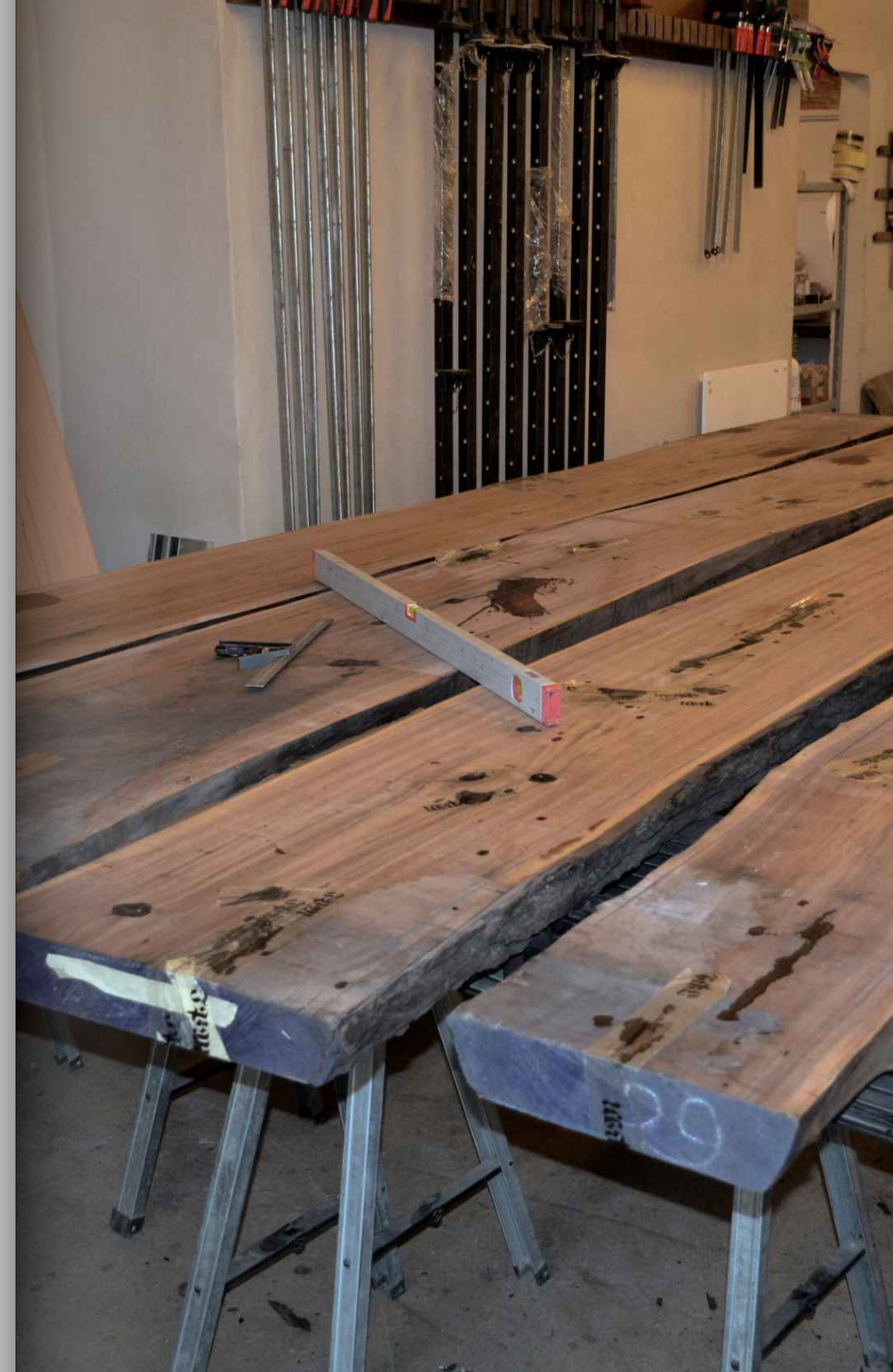

“ These processes have something primal, inviting you to touch the smooth, rounded surfaces and deeply inhale the scent of freshly sanded wood. ”



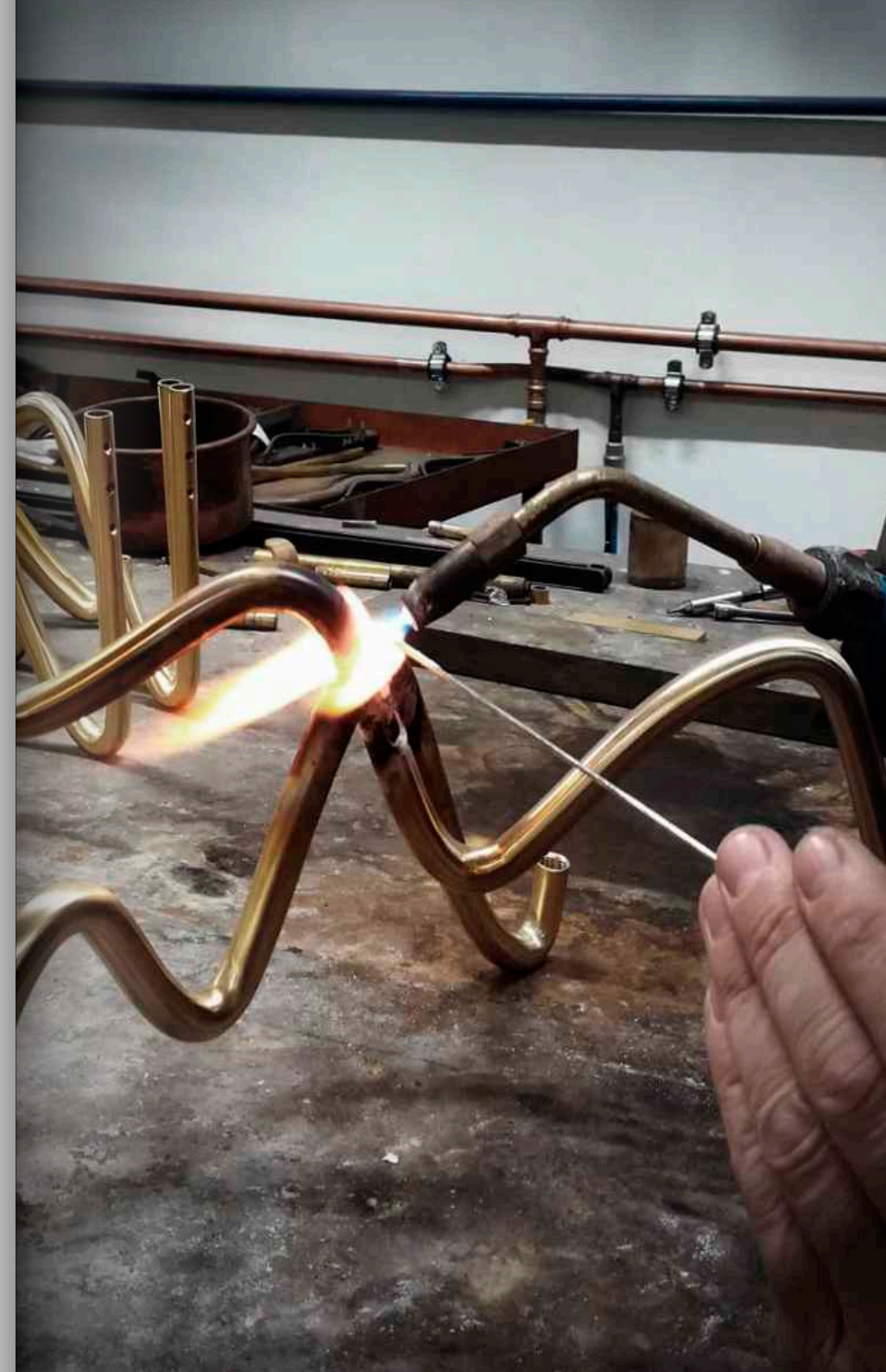

“ You find yourself standing still, enveloped by the warmth of the furnace, mesmerized by the molten crystal, admiring the skilled hands shaping the material, giving birth to something unique. ”

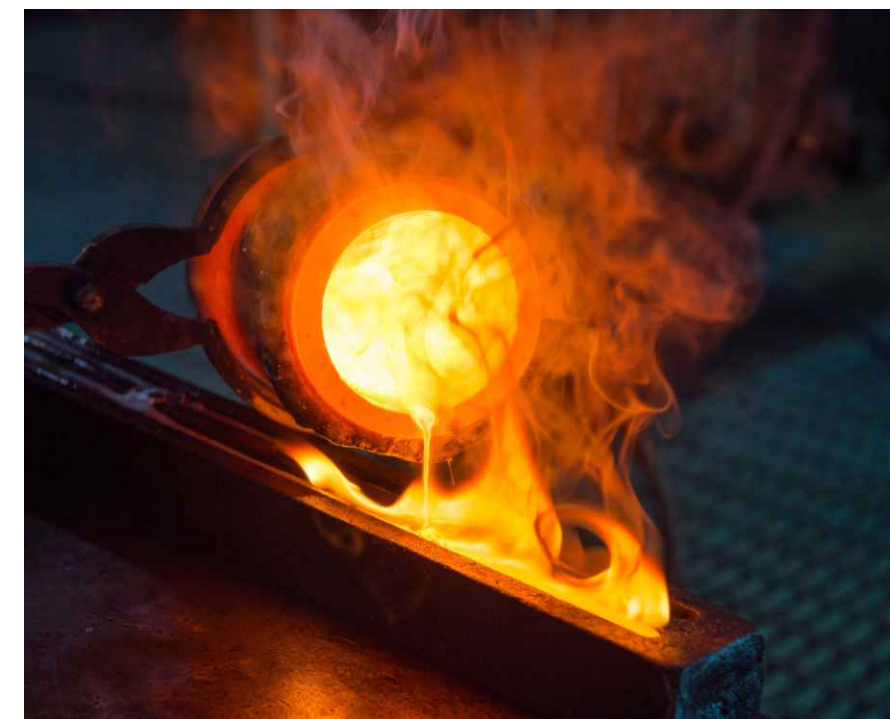

Le nostre collezioni, *our collections*

IL PEZZO **12**

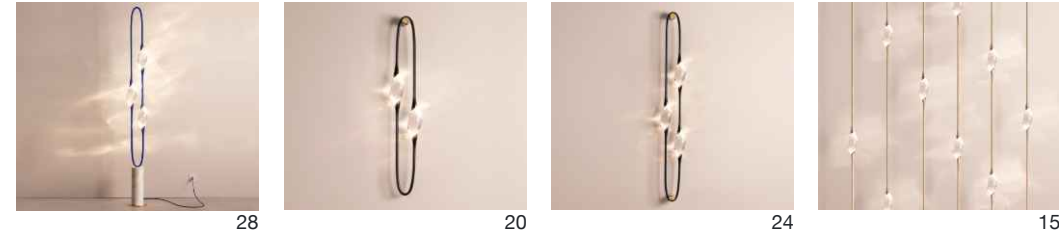
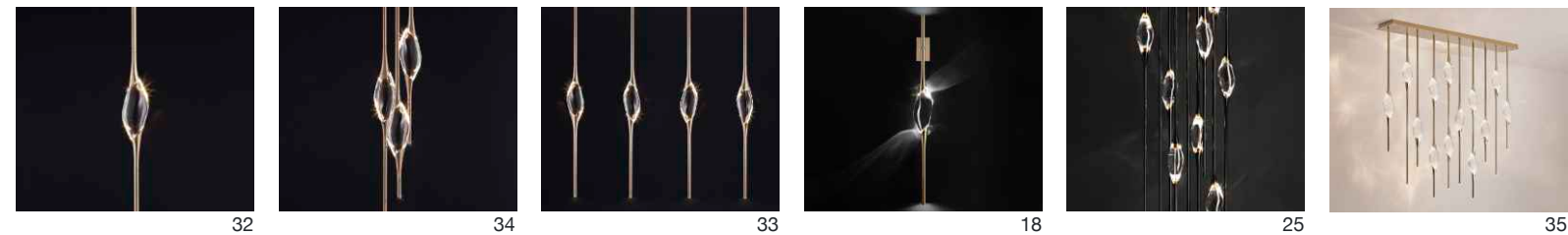

IL PEZZO **10**

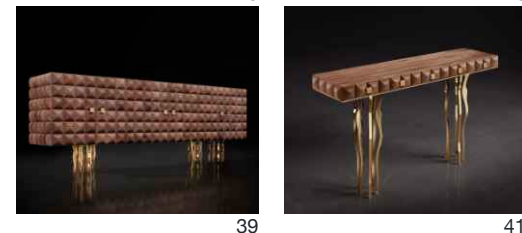

IL PEZZO **3**

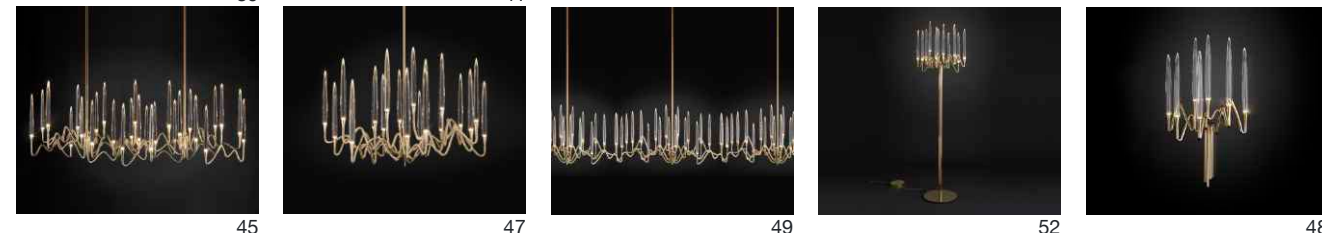

IL PEZZO **2**



IL PEZZO **1**



IL PEZZO **6**



79



82



84

IL PEZZO **8**



87



90



92



94

IL PEZZO **12**

“ a female figure carrying in her womb the light ”



IL PEZZO 12 FLOOR TO CEILING
Satin brass and nickel finish



IL PEZZO 12 FLOOR TO CEILING
Satin brass and nickel finish



IL PEZZO 12 FLOOR TO CEILING
Satin brass and nickel finish

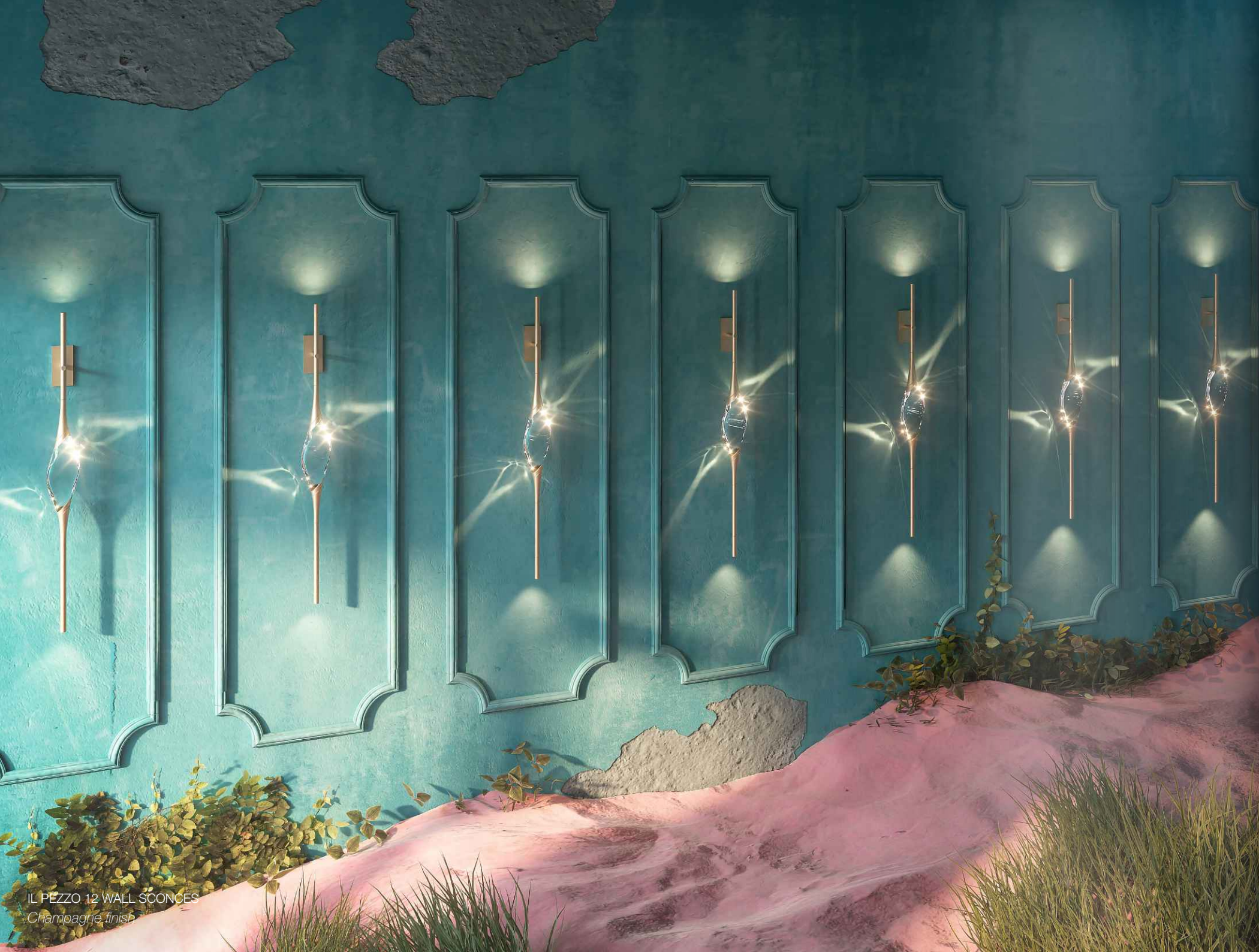

IL PEZZO 12 WALL SCONCES
Champagne finish



IL PEZZO 12 WALL SCONCE
Champagne finish

“ The shape of the crystal is not random. While it may resemble a drop, it actually represents a woman’s womb, a symbol of the light I once carried within me as we awaited our daughter ”



IL PEZZO 12 WALL SCONCES WITH TWO LIGHTS
Black and gold finish



IL PEZZO 12 WALL SCONCE WITH TWO LIGHTS
Black and gold finish



IL PEZZO 12 WALL SCONCE WITH TWO LIGHTS
Black and gold finish

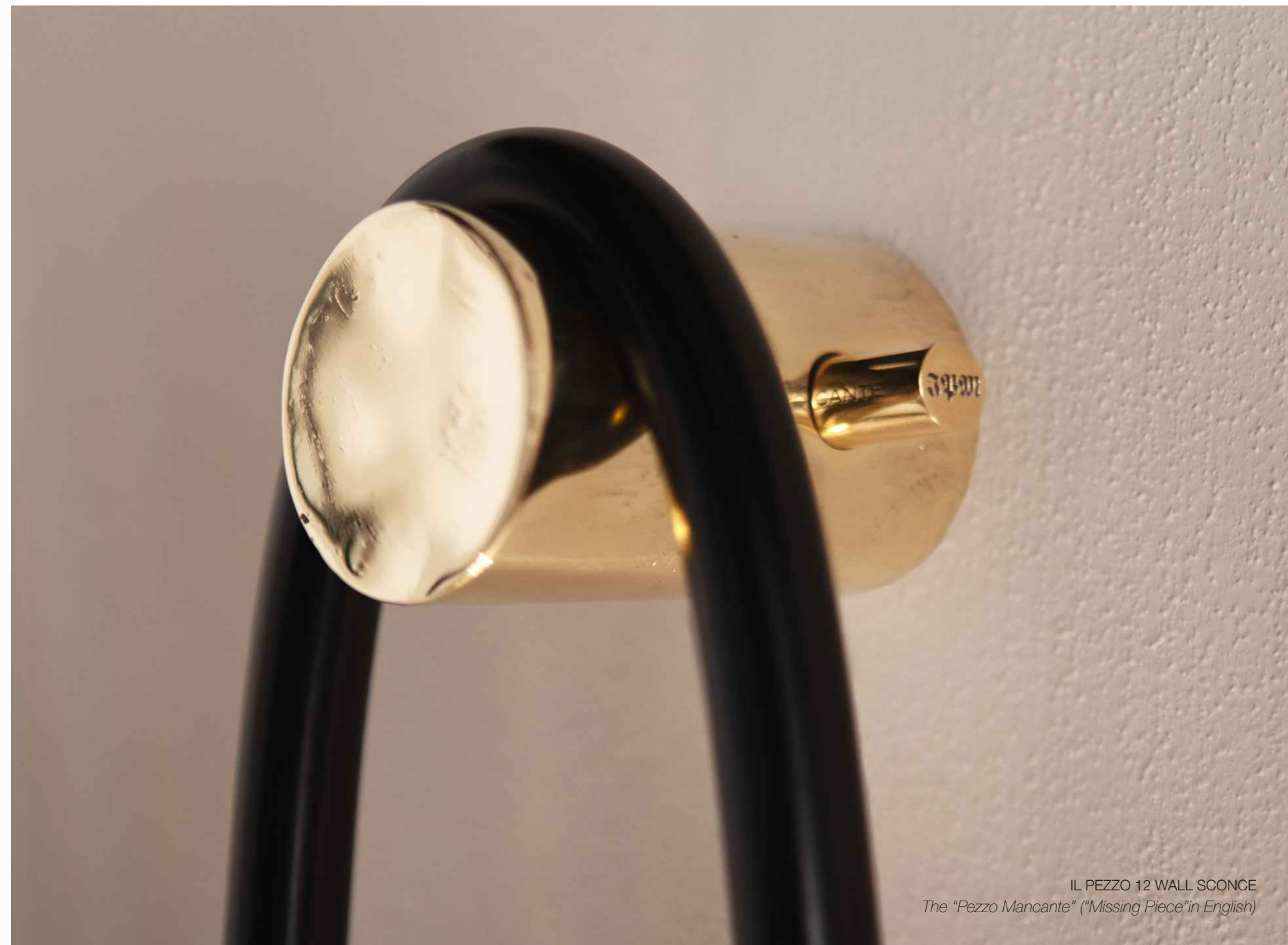

IL PEZZO 12 WALL SCONCE
The "Pezzo Mancante" ("Missing Piece" in English)



IL PEZZO 12 WALL SCONCE WITH THREE LIGHTS
Bronze and gold finish



IL PEZZO 12 CLUSTER CHANDELIER
Black and gold finish

“ These pieces are sculptures of light, born from passion, crafted by hand, and tailored to inhabit each space as a unique creation. ”

IL PEZZO 12 CLUSTER CHANDELIER
Black and gold finish



IL PEZZO 12 CLUSTER CHANDELIER
Solid crystals illuminated by LEDs

“ Born in Blue Majorelle finish, inspired by our love for the incredible colors of Morocco, especially that vibrant, deep blue found in traditional Berber burnouses. ”

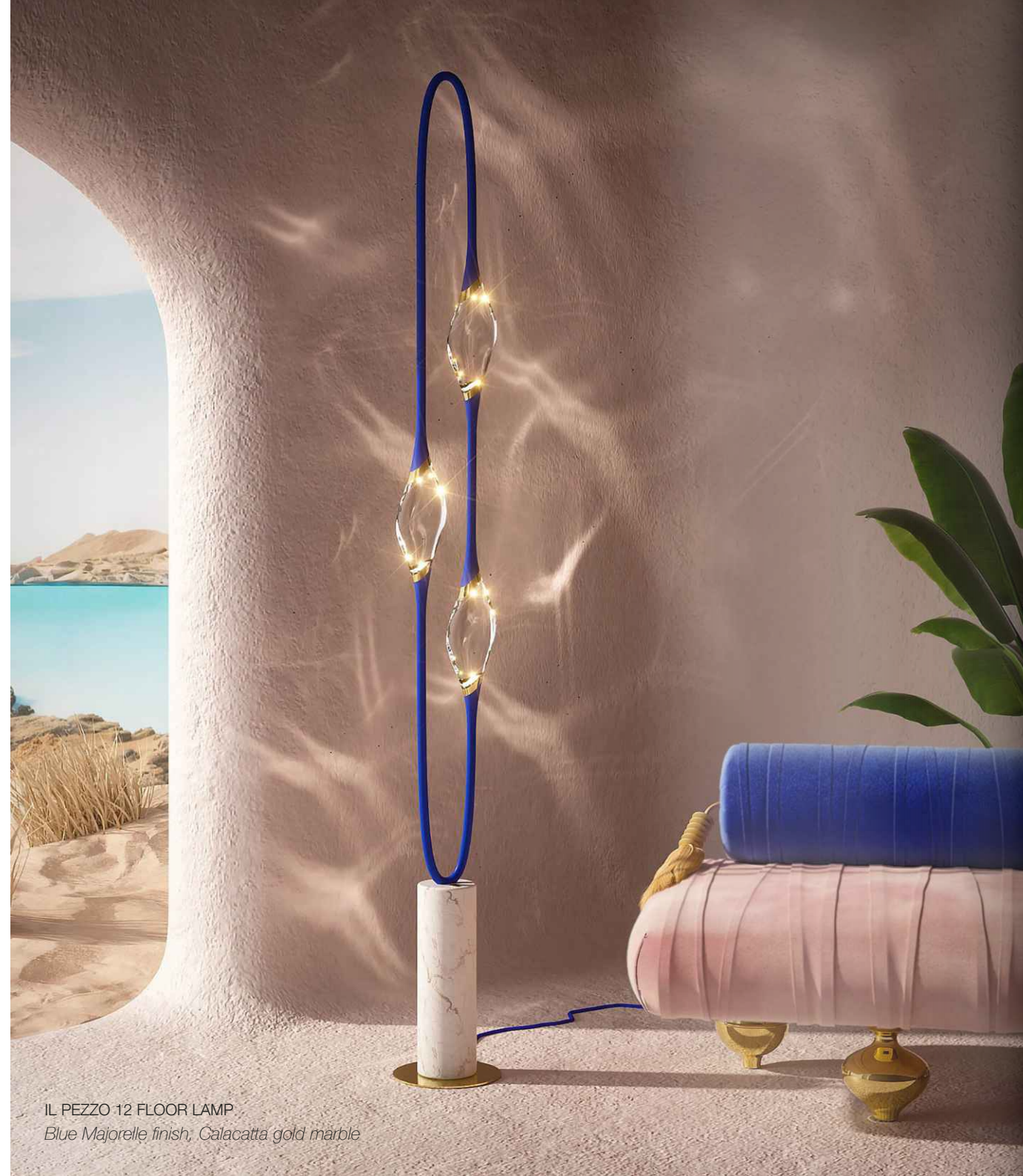

IL PEZZO 12 FLOOR LAMP
Blue Majorelle finish, Calacatta gold marble



IL PEZZO 12 FLOOR LAMP
"Pigino" dimmable remote controller in Blue Majorelle finish

“ The
Missing Piece
is a seal of an
ongoing search
we all undertake.
A small cylinder
that turns an object
into memory,
a passage between
those who
created it and
those who will live
with it. ”

IL PEZZO 12 FLOOR LAMP
The "Pezzo Mancante" ("Missing Piece" in English) nested on the base



IL PEZZO 12 FLOOR LAMP
Black and gold finish, Royal Black marble



IL PEZZO 12 PENDANT
Gold finish

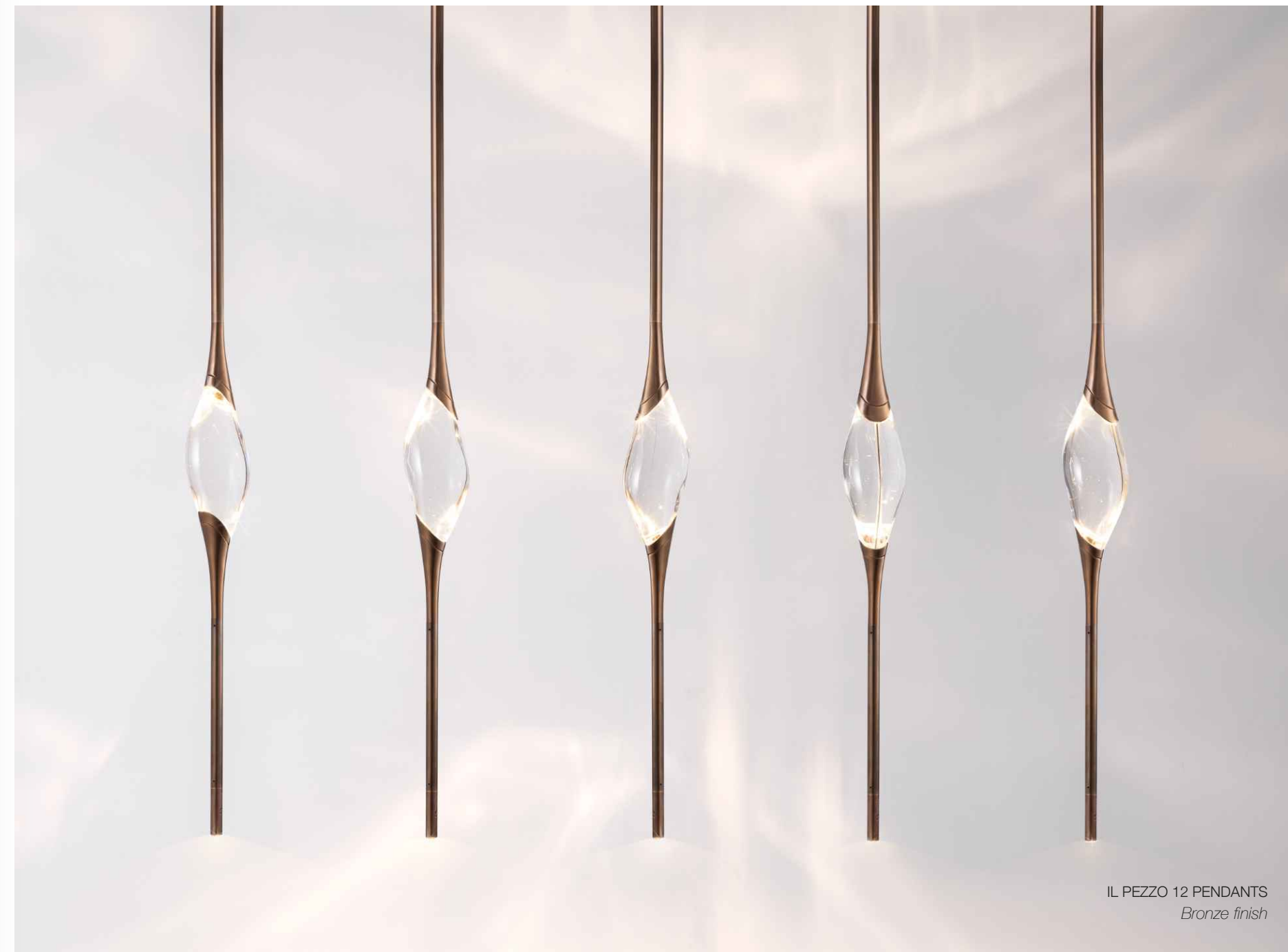

IL PEZZO 12 PENDANTS
Bronze finish

“ The solid crystal comes to life through the expertise of Tuscan glass masters, who shape molten material into molds, transforming it into a work of art. ”



IL PEZZO 12 ROUND CHANDELIER
Gold finish



IL PEZZO 12 STAGGERED CHANDELIER
Satin brass finish



IL PEZZO 12 COLLECTION
Solid crystals illuminated by LEDs

IL PEZZO **10**

“ *a medieval Florentine palace over the Arno river* ”



IL PEZZO 10 CREDENZA + IL PEZZO 12 ROUND CHANDELIER
Solid walnut and gold finish

“ In creating this piece, we sought to pay homage to our city, Florence, bringing to life the ancient stones of her palaces through wood, transforming them into a tactile creation that invites touch. ”



IL PEZZO 10 CREDENZA
Solid walnut, gold finish base and doors handles



IL PEZZO 10 CONSOLE
Solid walnut, gold finish base and drawers handles, with three drawers

“ Hand-sculpted
and cast in
lost-wax, these
handles contrast
beautifully
with the wood,
resembling delicate,
shimmering drapes.
This is our love for
details. ”



IL PEZZO 3

“ *the sinuous shapes of the Arabic calligraphic art* ”



IL PEZZO 3 LONG CHANDELIER
Gold finish



IL PEZZO 3 LONG CHANDELIER
Champagne finish



IL PEZZO 3 ROUND CHANDELIER
Gold finish

“ In designing
Il Pezzo 3 collection,
we drew inspiration
from the fascinating
art of Arabic
calligraphy, crafting
intricate structures
of lines and
curves that flow in
a continuous
motion. ”



IL PEZZO 3 WALL SCONCE
Gold finish



IL PEZZO 3 ENDLESS CHANDELIER + IL PEZZO 8 BLACK TABLE
Gold and black finishes



“ The charm of ancient candelabras comes to life in this piece, with its elegant structure and candles crafted from solid crystal, illuminated by advanced yet refined LED technology. ”



IL PEZZO 3 FLOOR LAMP
Gold finish



IL PEZZO 3 FLOOR LAMP
Nickel finish

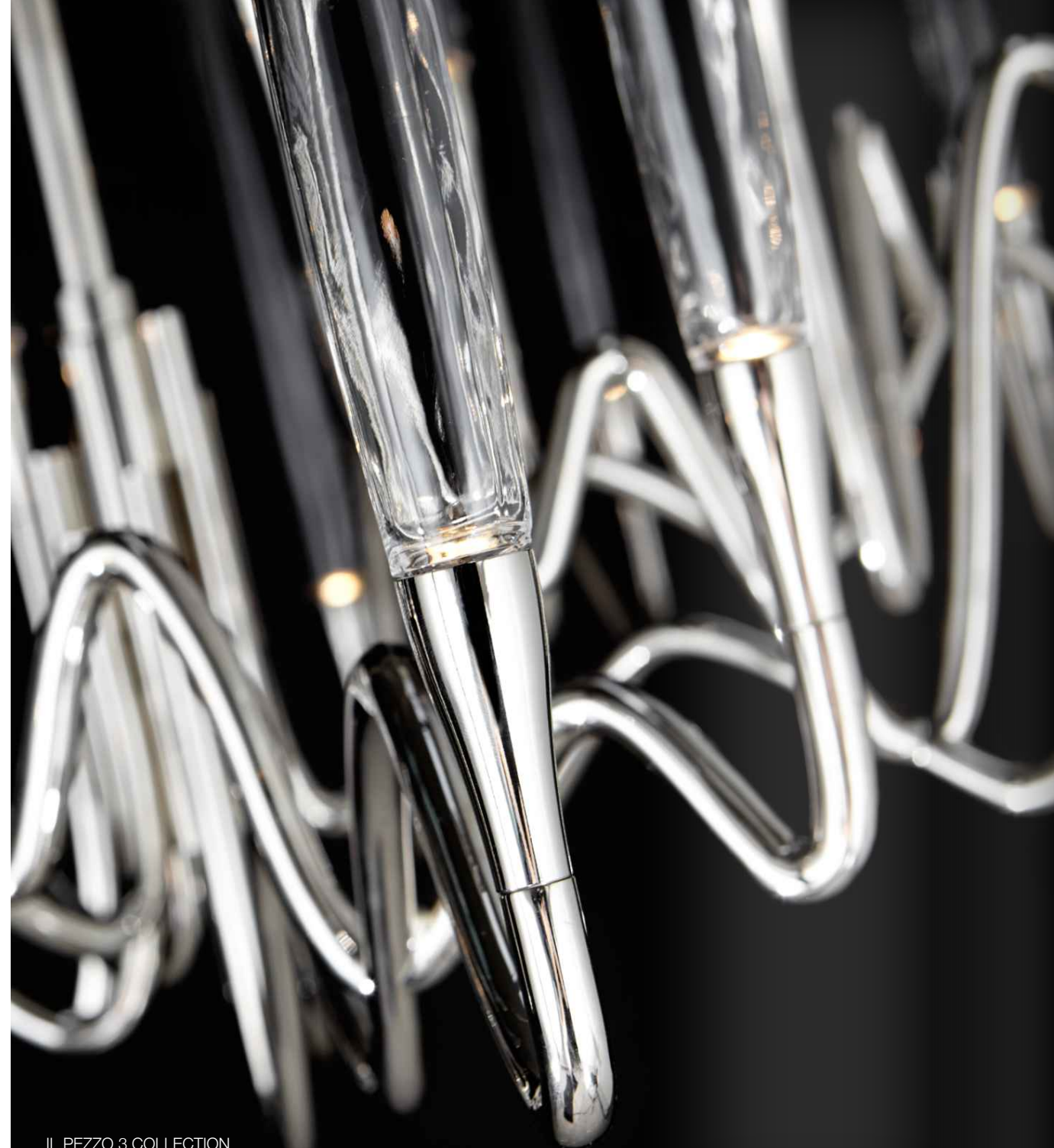

IL PEZZO 3 COLLECTION
Hand-bent structure and solid crystals illuminated by LEDs

IL PEZZO 2

“ familiar sensations and a personal reading of time ”



IL PEZZO 2 NIGHTSTAND + IL PEZZO 12 WALL SCONCE
Walnut and gold finish

“ We feel close to this collection, one of the first we designed. We were in a cottage, the landscape covered in snow, designing all day, every day. Just the two of us, with our creativity and passion, making our dream (Il Pezzo Mancante) come true. ”



IL PEZZO 2 NIGHTSTAND
Solid walnut, white Carrara marble top, with two drawers



IL PEZZO 2 NIGHTSTANDS
Solid walnut, white Carrara marble tops, nickel bases



IL PEZZO 2 HIGHBOY
Solid walnut, black Marquinia marble top

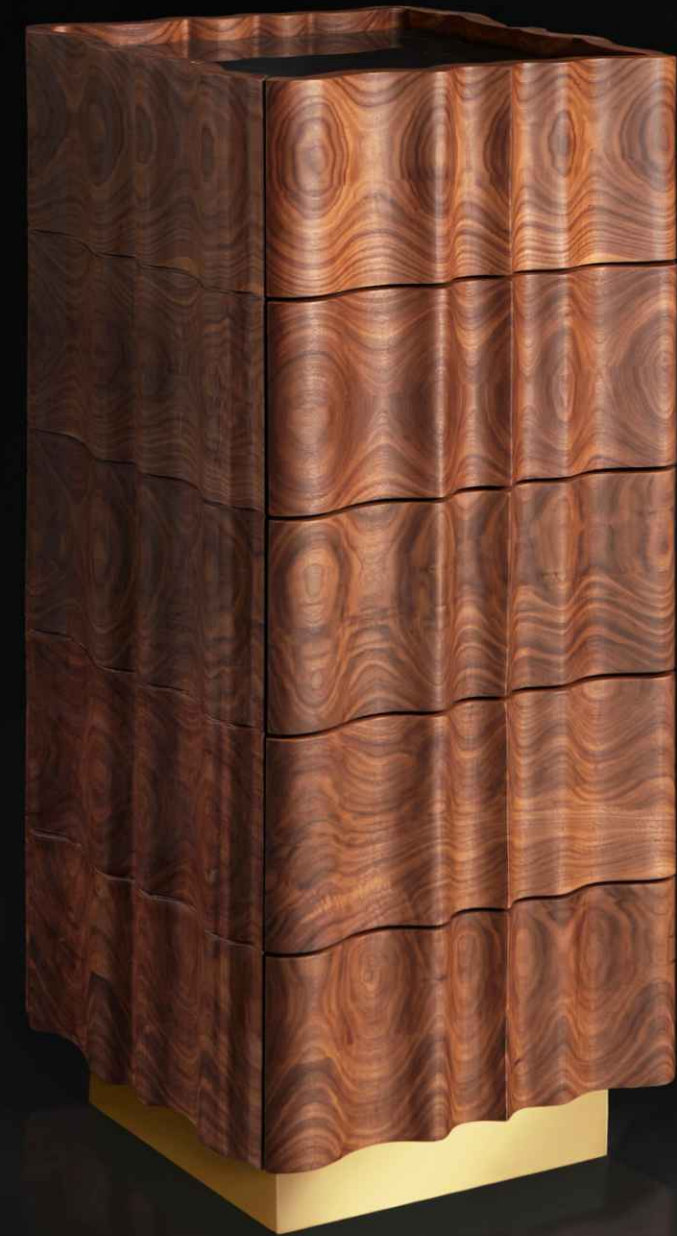

IL PEZZO 2 HIGHBOY
Solid walnut, black Marquinia marble top, gold base

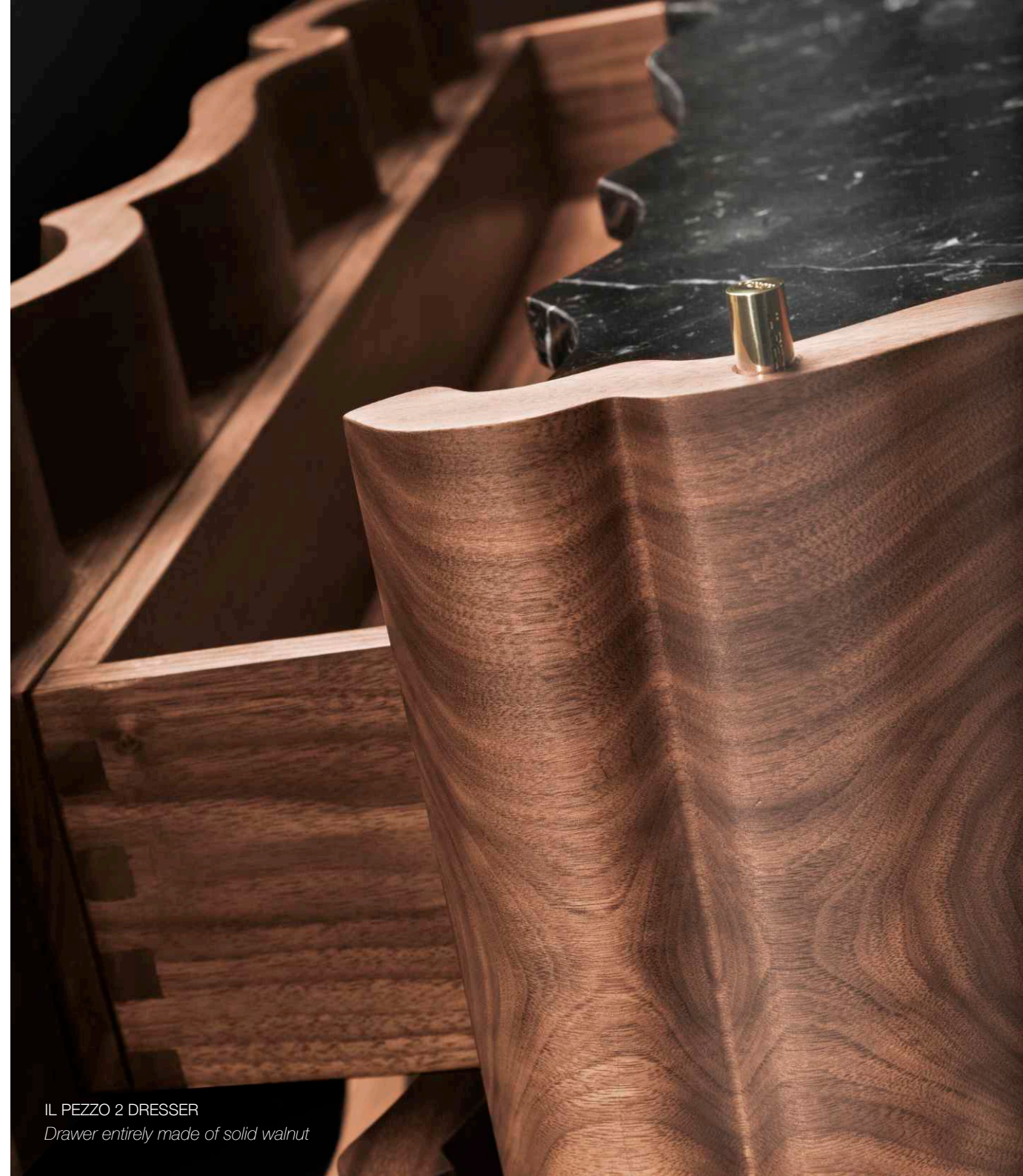

IL PEZZO 2 DRESSER
Drawer entirely made of solid walnut



IL PEZZO 2 DRESSER
Solid walnut, black Marquina marble top, gold base



IL PEZZO 2 COFFEE TABLE
Solid walnut, black Marquinia marble top, gold base, with two drawers

IL PEZZO **1**

“ a multiethnic composite of discipline and freedom ”



IL PEZZO 1 BLACK CREDENZA + IL PEZZO 3 WALL SCONCES
Ebonized solid oak and gold finish



IL PEZZO 1 BLACK CREDENZA
Ebonized solid oak, bronze base and details



IL PEZZO 1 COLLECTION
Brass casting feet in bronze finish

“ This credenza embodies our initial approach to noble materials, solid wood, marble and hand-cast brass, expressing our vision of bringing them to life in contemporary yet timeless pieces. A vision that continues to guide us every day. ”



IL PEZZO 1 CREDENZA
Solid walnut + solid wenge, black Marquina marble top and black nickel base



IL PEZZO 1 CREDENZA
Solid walnut + solid wenge, black Marquina marble top and gold base

“ Sinuous,
soft folds embrace
the seating,
while solid cast
feet anchor it to the
ground. Detail
and balance guide
us, in search of a
harmonious,
elegant whole. ”



IL PEZZO 1 POUF
Beige leather, gold base



IL PEZZO 1 BENCH
Black leather, gold base



IL PEZZO 1 DAYBED
Night blue and anthracite velvet, fuchsia tassels and gold base



IL PEZZO 1 DAYBED
Cotton and silk-based tassel and gold details

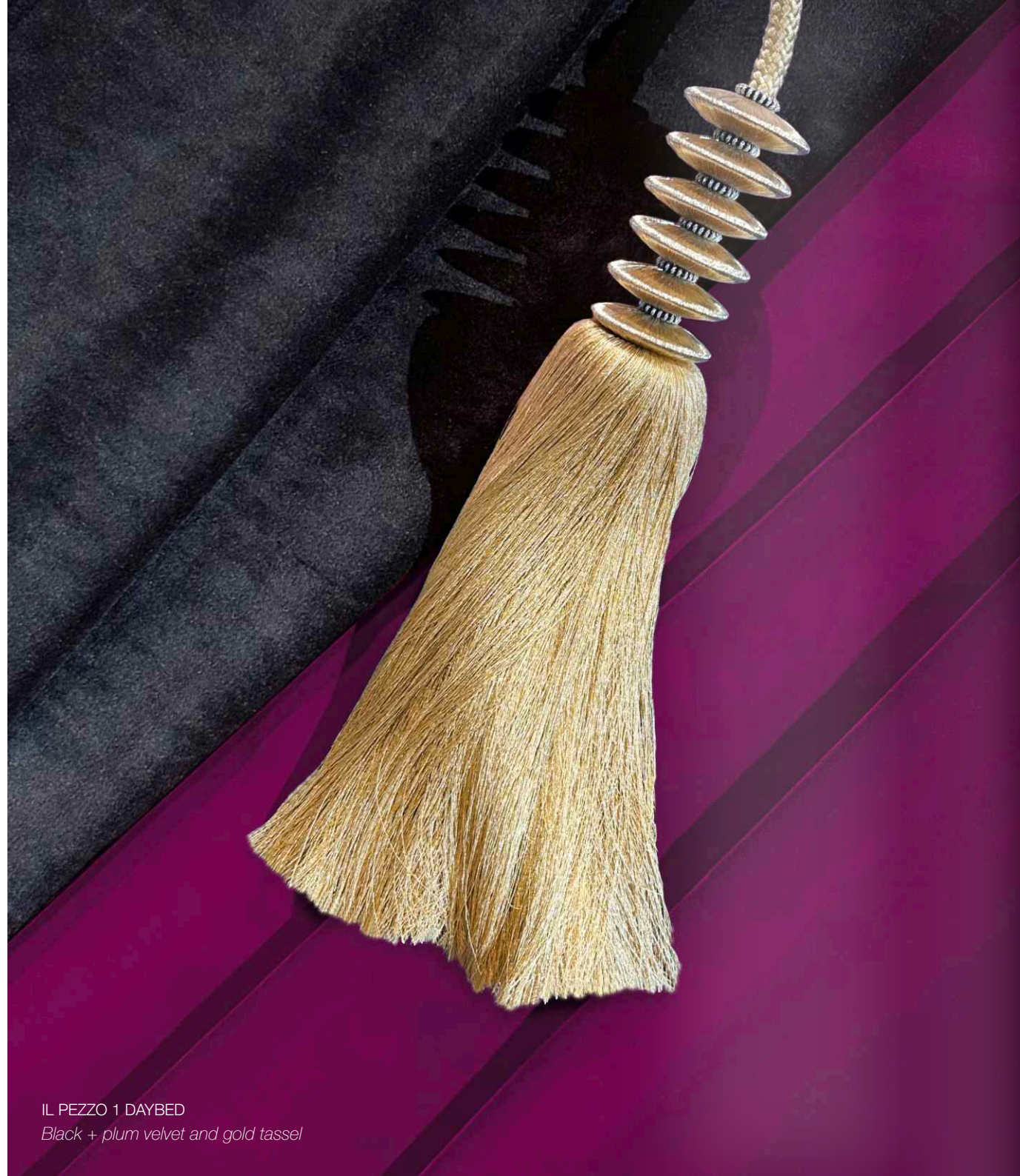

IL PEZZO 1 DAYBED
Black + plum velvet and gold tassel

IL PEZZO **6**

“ a massive, sophisticated and timeless whole ”



IL PEZZO 6 LONG TABLE
Solid walnut and ash top, gold base



IL PEZZO 6 LONG TABLE
Solid walnut and wenge-stained oak top, nickel base



“ Solid wood is a living material. It keeps moving, breathing, carrying the scent of nature over time. We've learned to respect it, through the crafting process and beyond, to create timeless pieces meant to be passed down for generations. ”

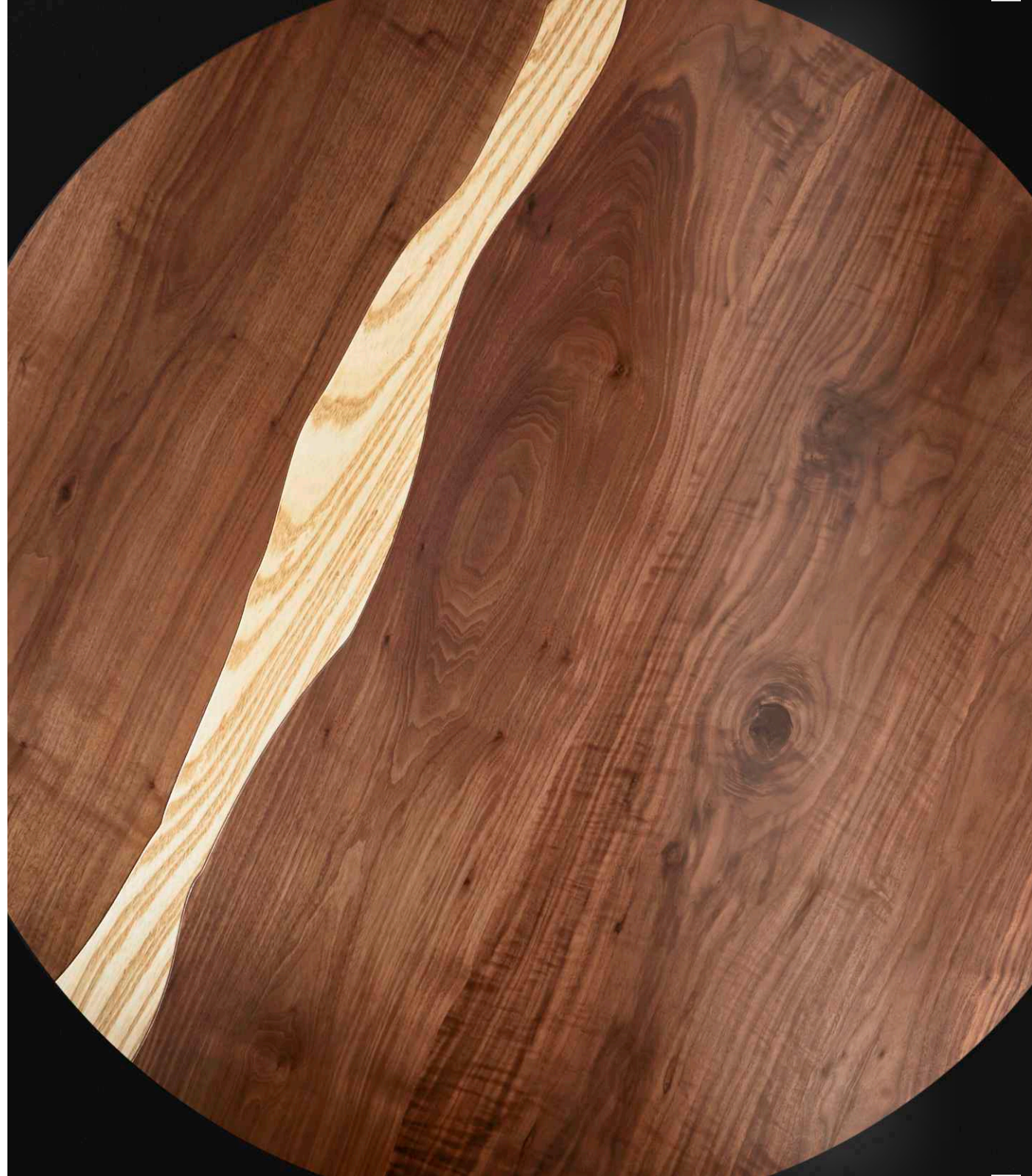

IL PEZZO 6 ROUND TABLE
Solid walnut and solid ash top, gold base



IL PEZZO 6 CONSOLE
Solid walnut and solid ash top, gold base

IL PEZZO 8

“ an intricate forest, romantic and sinuous ”



IL PEZZO 8 TABLE
Solid walnut top with nickel inlays, satin brass + bronze + nickel base



IL PEZZO 8 TABLE
Solid walnut top with nickel inlays, satin brass + bronze + nickel base



IL PEZZO 8 TABLE
The "Pezzo Mancante" ("Missing Piece" in English) engraved with the serial number



“ The magic of wood comes alive at the touch of the ebonized surface: warmth, solidity, materiality, and the primal scent of this ancient material. ”

IL PEZZO 8 BLACK TABLE
Ebonized solid oak top with gold metal inlays, black + gold base



IL PEZZO 8 GLASS TABLE
Satin brass + bronze + nickel base



IL PEZZO 8 GLASS TABLE
Glass top, satin brass + bronze + nickel base

“ We stand
mesmerized before
the glowing
furnace, fascinated
by skilled hands
shaping molten
metal, mastering
the molds and
giving life
to sculptural forms
that rise into this
forest of legs. ”

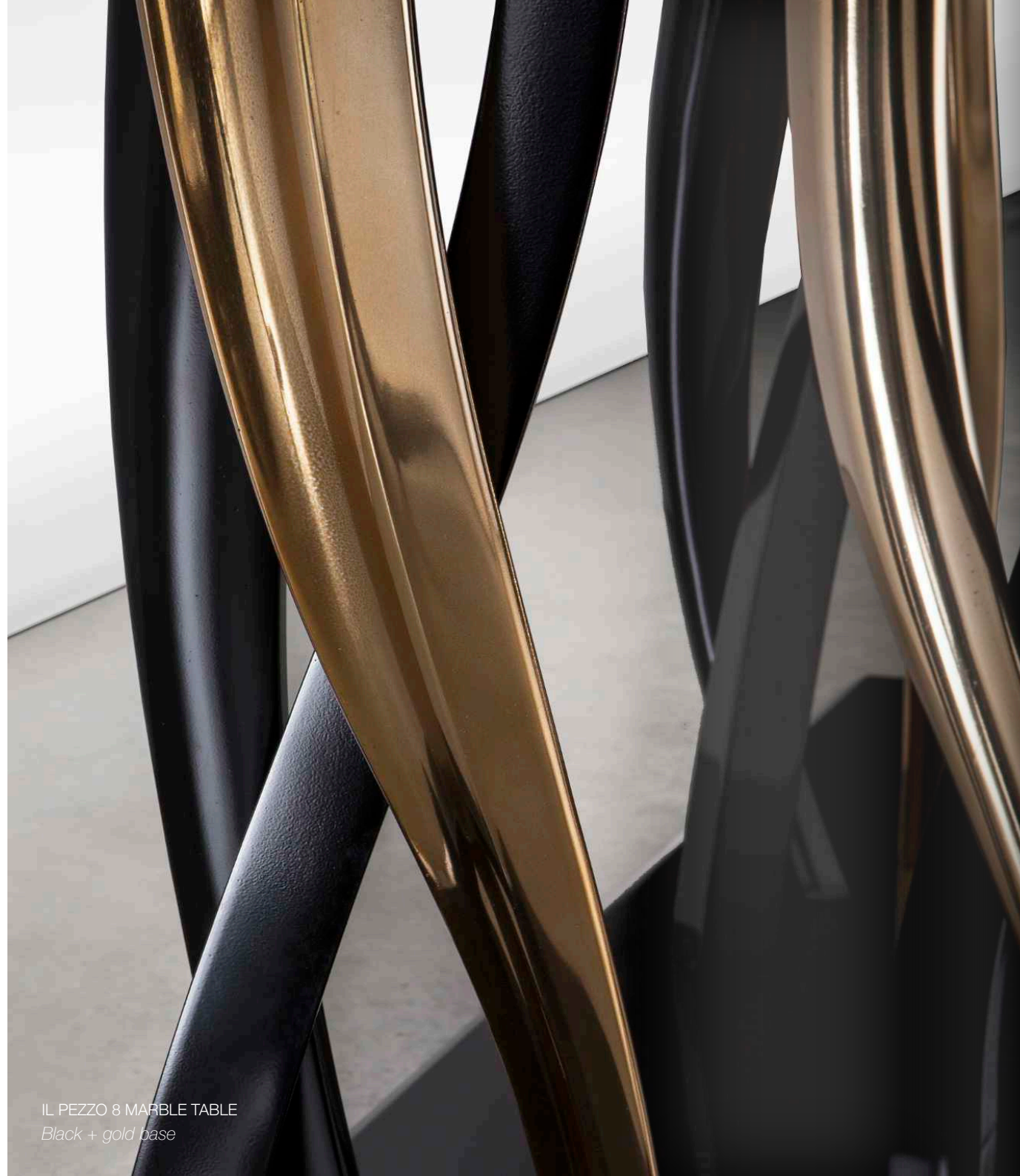

IL PEZZO 8 MARBLE TABLE
Black + gold base



IL PEZZO 8 MARBLE TABLE
Black Marquina marble top, black + gold base



Il viaggio de Il Pezzo Mancante al Castello di Bisarno,
the journey of Il Pezzo Mancante to the Castle of Bisarno













Informazioni tecniche, technical data

IL PEZZO 1

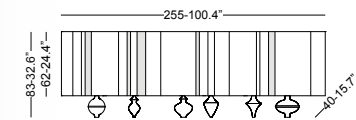

credenza
sideboard

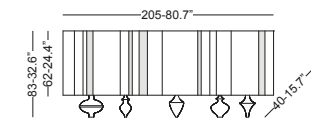

credenza
sideboard

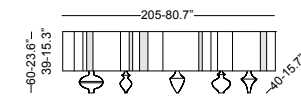

consolle tv
tv console

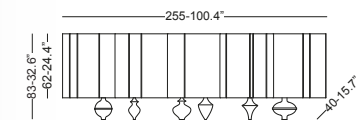

credenza nera
black credenza

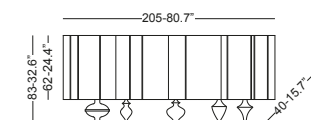

credenza nera
black credenza

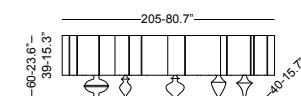

consolle tv
tv console

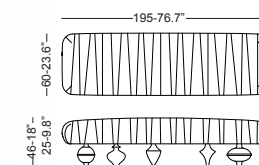

panca
bench

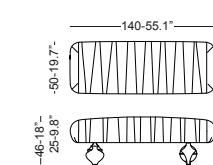

panca
bench

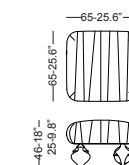

pouf
pouf

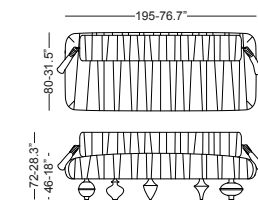

dormeuse
daybed

Struttura: noce massello + frassino massello | noce massello + wengé massello | rovere massello tinto nero **Top:** marmo Carrara bianco | marmo nero Marquinia **Base in fusione di ottone con colata in sabbia:** disponibile in varie finiture **Rivestimento:** pelle prima scelta | velluto
Structure: solid walnut + solid ash | solid walnut + solid wenge | black stained solid oak **Top:** white Carrara marble | Marquinia black marble **Sand-cast brass base:** available in different finishes **Upholstery:** fine quality leather | velvet

IL PEZZO 2

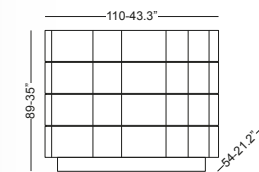

cassettiera
dresser

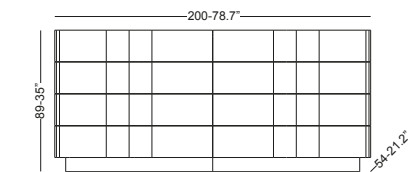

cassettiera
dresser

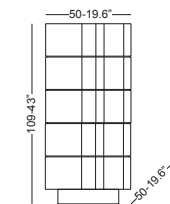

settimino
highboy

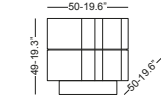

comodino
nightstand

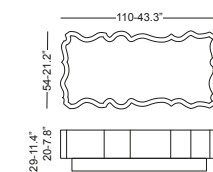

tavolo basso
coffee table

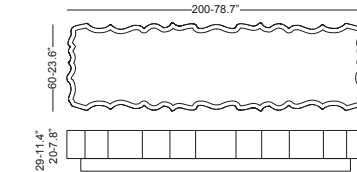

tavolo basso
coffee table

Struttura: noce massello **Top:** marmo Carrara bianco | marmo nero Marquinia **Base in ottone saldato a mano:** disponibile in varie finiture
Structure: solid walnut **Top:** white Carrara marble | Marquinia black marble **Hand-welded brass base:** available in different finishes

IL PEZZO 3

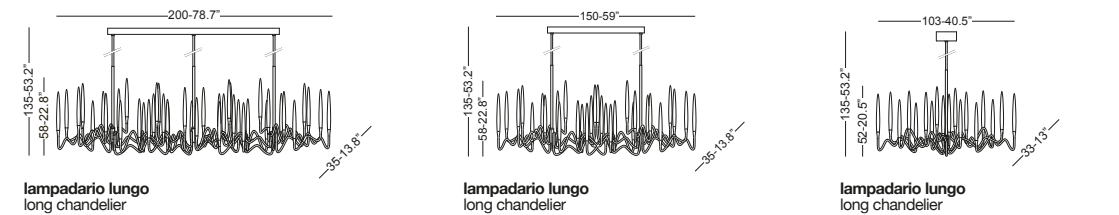

lampadario lungo
long chandelier

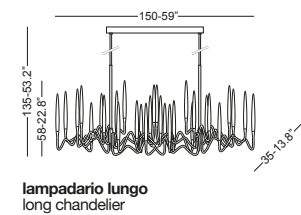

lampadario lungo
long chandelier

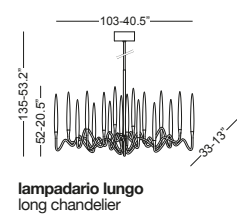

lampadario lungo
long chandelier

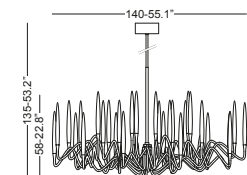

lampadario tondo
round chandelier

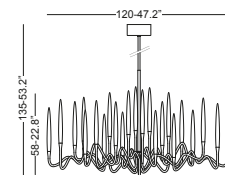

lampadario tondo
round chandelier

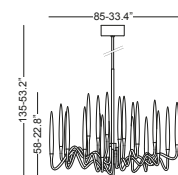

lampadario tondo
round chandelier

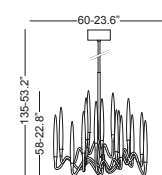

lampadario tondo
round chandelier

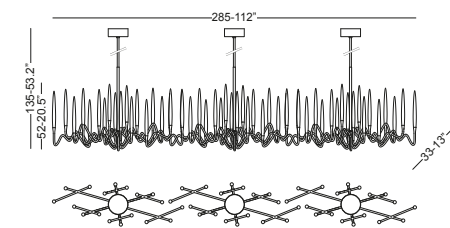

lampadario infinito
endless chandelier

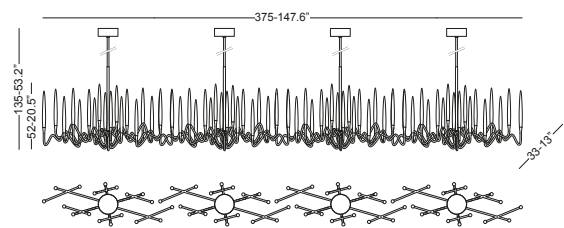

lampadario infinito
endless chandelier

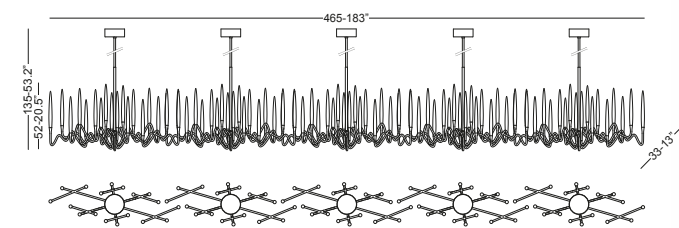

lampadario infinito
endless chandelier

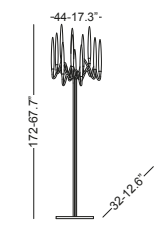

lampada da terra
floor lamp

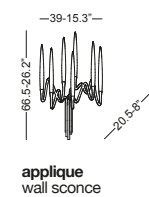

applique
wall sconce

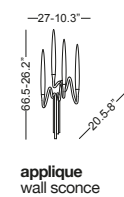

applique
wall sconce

Struttura in ottone forgiato e saldato a mano: disponibile in varie finiture **Diffusori:** cristallo pieno **Sorgenti luminose:** LED
Hand-forged and welded brass frame: available in different finishes **Diffusers:** solid crystal **Light sources:** LED



IL PEZZO 6

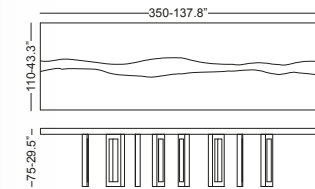

tavolo
table

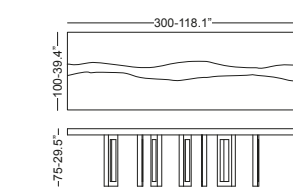

tavolo
table

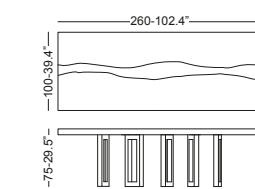

tavolo
table

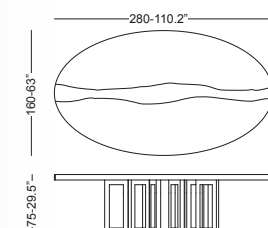

tavolo
table

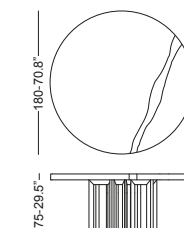

tavolo
table

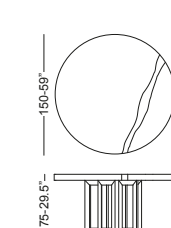

tavolo
table

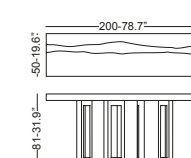

consolle
console

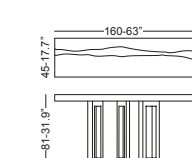

consolle
console

Top: noce massello + frassino massello | noce massello + rovere massello tinto wengé **Base in ottone saldato a mano:** disponibile in varie finiture
Top: solid walnut + solid ash | solid walnut + wenge stained solid oak **Hand-welded brass base:** available in different finishes

IL PEZZO 8

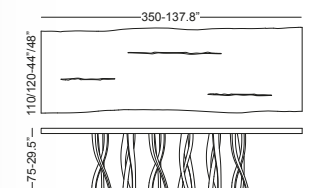

tavolo nero
black table

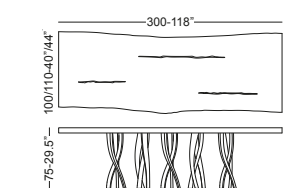

tavolo nero
black table

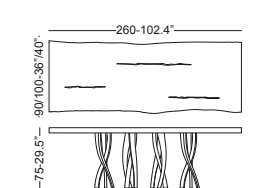

tavolo nero
black table

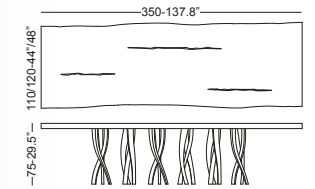

tavolo nero
black table

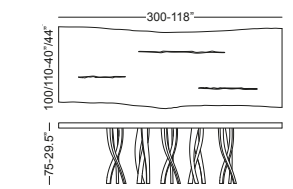

tavolo nero
black table

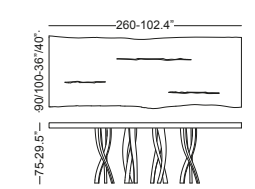

tavolo nero
black table

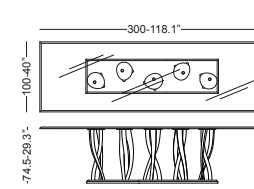

tavolo in vetro
glass table

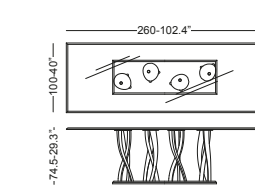

tavolo in vetro
glass table

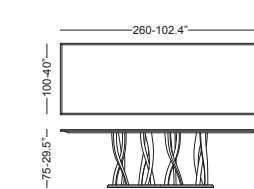

tavolo in marmo
marble table

Top: noce massello | rovere massello tinto nero | marmo Marquinia | vetro trasparente **Base in fusione con colata in sabbia:** ottone satinato + bronzo + nichel | nero + oro
Top: solid walnut | black stained solid oak | Marquinia marble | clear glass **Sand-cast base:** satin brass + bronze + nickel | black + gold

IL PEZZO **10**

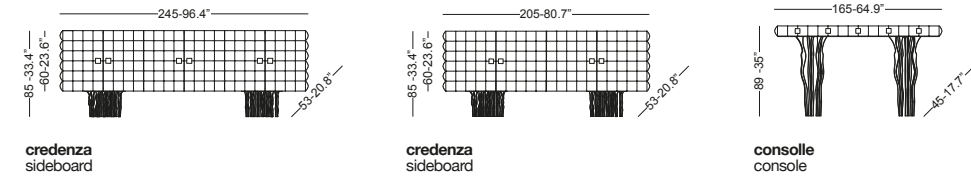

Struttura: noce massello **Base e pomelli:** fusione di ottone disponibile in varie finiture
Structure: walnut **Base and handles:** brass cast, available in different finishes

IL PEZZO **12**

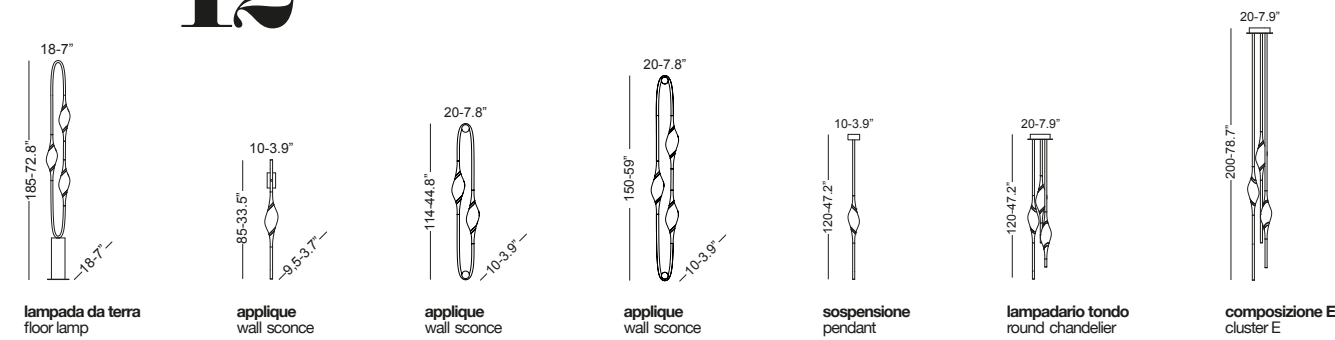

lampada da terra floor lamp
 applique wall sconce
 applique wall sconce
 applique wall sconce
 sospensione pendant
 lampadario tondo round chandelier
 composizione E cluster E

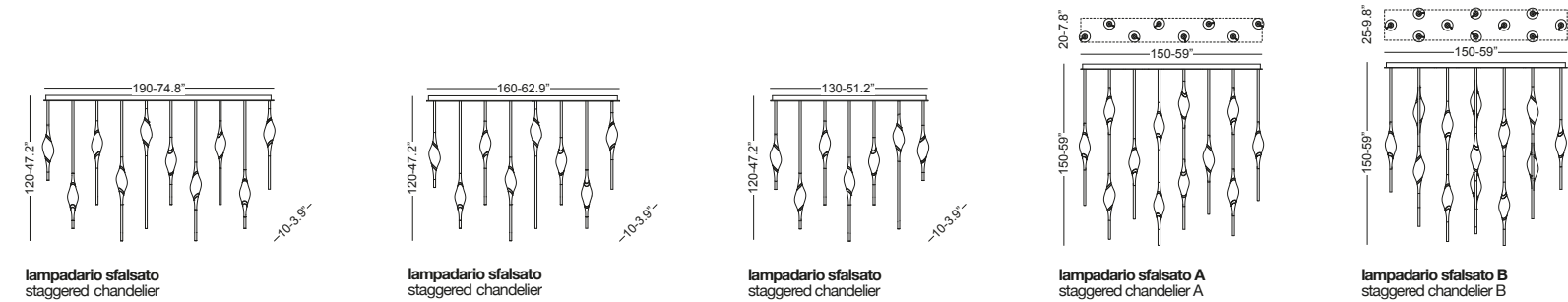

lampadario sfalsato staggered chandelier
 lampadario sfalsato staggered chandelier
 lampadario sfalsato staggered chandelier
 lampadario sfalsato A staggered chandelier A
 lampadario sfalsato B staggered chandelier B

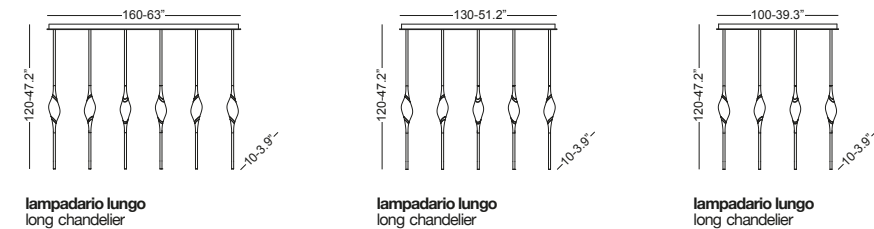

lampadario lungo long chandelier
 lampadario lungo long chandelier
 lampadario lungo long chandelier



IL PEZZO **12**

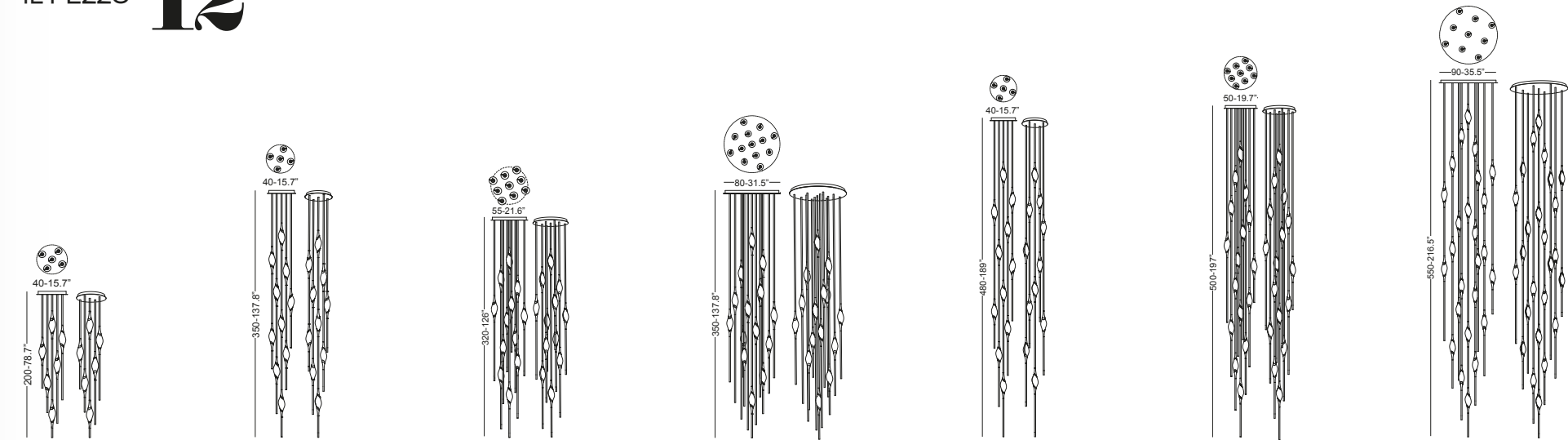

composizione J cluster J
 composizione D cluster D
 composizione A cluster A
 composizione G cluster G
 composizione B cluster B
 composizione C cluster C
 composizione L cluster L

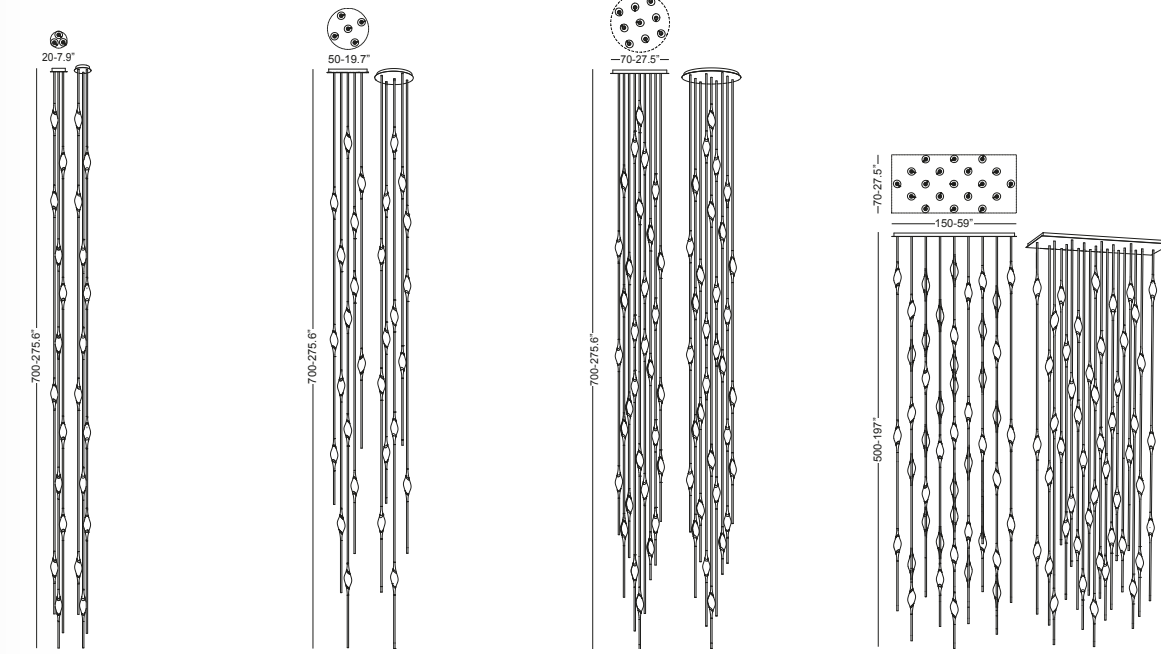

composizione H cluster H
 composizione F cluster F
 composizione I cluster I
 composizione M cluster M

Struttura in ottone: disponibile in varie finiture **Diffusori:** cristallo pieno **Sorgenti luminose:** LED
Brass frame: available in different finishes **Diffusers:** solid crystal **Light sources:** LED



IL PEZZO **12**

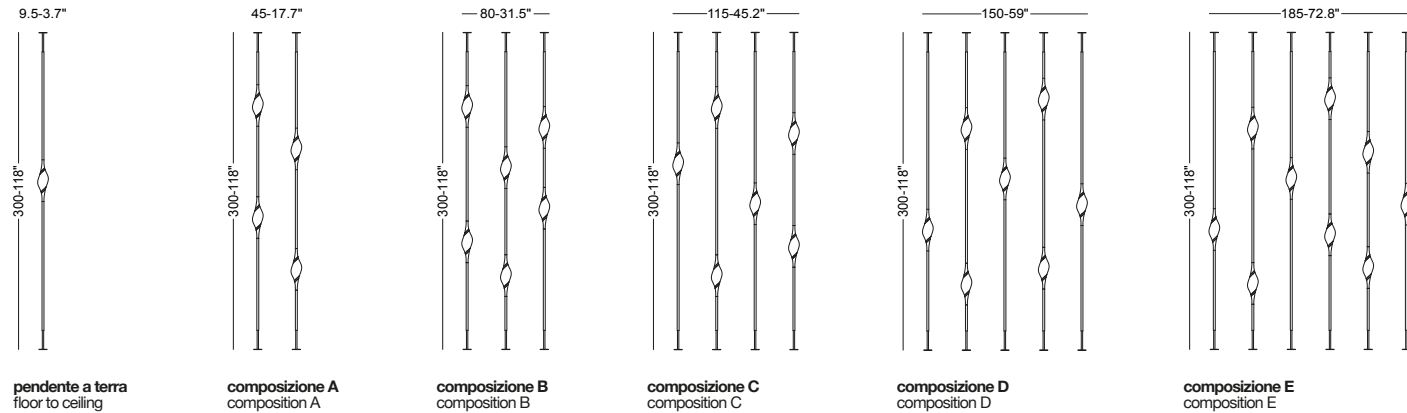

Struttura in ottone: disponibile in varie finiture **Diffusori:** cristallo pieno **Sorgenti luminose:** LED
Brass frame: available in different finishes **Diffusers:** solid crystal **Light sources:** LED



IL PEZZO MANCANTE

HANDCRAFTED IN FLORENCE SINCE 2010

Il Pezzo Mancante srl

via Rocca Tedalda 31 50136 Firenze, Italia
ph | whatsapp +39 055 3989901
info@ilpezzomancante.com

Design and Art Direction

Barbara Bertocci + Cosimo Terzani

Concept

Jean-Yves Malbos + Paolo Bonsignore

Images

Alessio Falchetti | Alessio Balleri | Centrofotografico | GFdesign | Superresolution | Alterama | Jacopo Taccogna

Printing

Fotolito Toscana – printed in Florence, February 2026

© IPM 2026

www.ilpezzomancante.com

IPM

IL PEZZO MANCANTE