

# Couture



***Lorenza Bozzoli***  
*Milano*



**Couture** è una collezione elegante ed esclusiva di complementi di arredo unici che si distingue per l'attenzione e la cura alla produzione, evidente nell'utilizzo di eccellenti materie prime, approccio sartoriale e lavorazione artigianale 100% Made in Italy, proprio come se si trattasse di abiti alta moda.

**Couture** is the elegant and exclusive collection of home accessories by Lorenza Bozzoli that stands out for its attention and care to the manufacturing process, evident in the use of superb raw materials, a sartorial approach, artisan craftsmanship carried out exclusively in Italy, as if it was for an Haute Couture collection.





I pouf **Couture** realizzati per l'indoor segnano l'inizio di un nuovo importante capitolo per Lorenza Bozzoli, affermata designer milanese che annovera tra le sue collaborazioni aziende internazionali quali Dedon, Moooi ed Alessi.

The **Couture** Poufs for indoor living mark the beginning of an important new chapter for Lorenza Bozzoli, a prominent italian designer boasting collaborations with the likes of big companies such as Dedon, Mooi and Alessi.











Realizzati con quattro disegni geometrici diversi, le combinazioni di colore oltre a quelle proposte a catalogo sono personalizzabili secondo le esigenze del cliente .

Created with four different looks / designs, in addition to the standard ones, the color palettes are customizable according to the client's preferences.





La proposta di pouf Couture si affina attraverso nuovi modelli come la panca a tre posti.  
The proposal of pouf Couture gets sharper through new models as the bench to three places.





La collezione *Couture* è arricchita da uno specchio a parete ispirato all'architettura razionalista. Questo progetto è caratterizzato da vetri specchiati in diversi colori ,contornati da profili in metallo ottonato. Anche lo specchio gode della presenza delle frange artigianali, elemento distintivo di tutta la serie.















COUTURE  
Lorenza Bozzoli  
Milano

COUTURE  
Lorenza Bozzoli  
Milano

COUTURE  
Lorenza Bozzoli  
Milano

COUTURE  
Lorenza Bozzoli  
Milano



COUTURE  
Lorenza Bozzoli  
Milano

COUTURE  
Lorenza Bozzoli  
Milano

COUTURE  
Lorenza Bozzoli  
Milano

COUTURE  
Lorenza Bozzoli  
Milano

COUTURE  
Lorenza Bozzoli  
Milano

COUTURE  
Lorenza Bozzoli  
Milano

COUTURE  
Lorenza Bozzoli  
Milano





COUTURE  
Lorenza Bozzoli  
Milano



Ogni colore di velluto può essere abbinato ad ogni colore di frange disponibili , come quella qui proposta o realizzata su richiesta del cliente.

Each color of fringes can be combined with any available velvet color, like the one proposed, or made specifically to the customer desires.







COUTURE  
Lorenzo Bazzoli  
Milano





### LUXURY LIVING

Elemento distintivo di questa collezione sono le frange artigianali tessute su telai dei primi del '700. La ricchezza delle lavorazioni e la varietà dei colori donano alle geometrie di design contemporaneo un richiamo agli anni Venti dal tocco esotico.

### LUXURY LIVING

The distinguishing feature of this collection are the artisanal fringes, woven on XVIII century-old looms. The opulence of the embellishments as well as the variety of colors provide the contemporary layout with a Twenties vintage allure and an exotic touch.





























Volumi, materiali e lavorazioni sono pensati per decorare ambienti come il soggiorno, la camera da letto, il bagno e il guardaroba con l'intento di personalizzare luoghi diversi e rendere gli spazi più dinamici e vivaci.

Volumes, materials and embellishments are ideal for decorating home interiors including living rooms, bed rooms and walk-in closet with the aim of customizing different environments and make them more lively and dynamic.



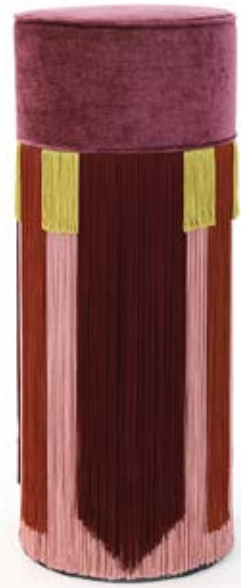

I pouf hanno quattro misure standard di catalogo con la possibilità di essere realizzati anche made to measure:

- Pouf 30 CM diametro: indicato come seduta aggiuntiva per soggiorno, cabina
- armadio, negozi di scarpe, cabine di prova...
- Pouf 40 CM diametro: indicato come seduta per vanity desk, sedute aggiuntive per soggiorno..
- Pouf 50 CM diametro: indicato come tavolino, piano di appoggio per vassoio, seduta...
- Pouf 70 CM diametro: indicato come sedute per più persone e anche come piano di appoggio multifunzionale per riviste e vassoi;

The poufs have 4 different standard measures with the possibility of a made-to-measure:

- Pouf 30 CM width: ideal as extra seat for the living room, walk-in closet, shoes store, fitting room...
- Pouf 40 CM width: ideal as seat for vanity desk, extra seat for living room..
- Pouf 50 CM width: ideal as table, as support for trays, extra seat in general...
- Pouf 70 CM width: ideal as seat for more people and a multi-functional support for magazines and trays;

La qualità del colore dipende dal monitor usato per la visualizzazione della brochure e può risultare diversa da schermo a schermo.

The quality of the color varies depending on the PC-screen used and it can be different from screen to screen.



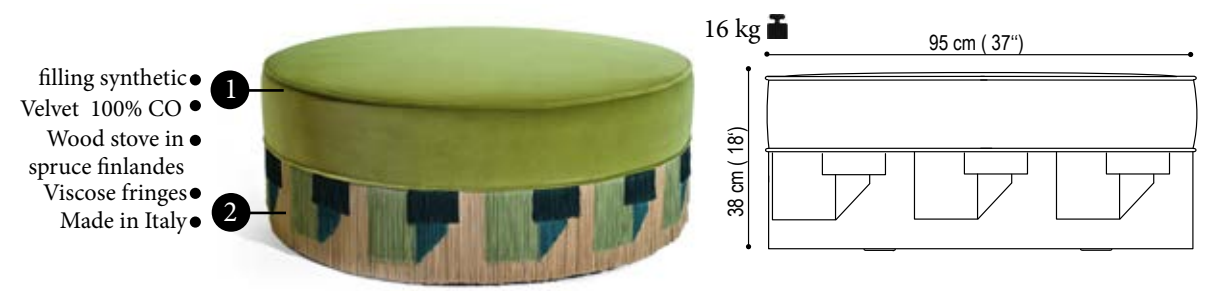
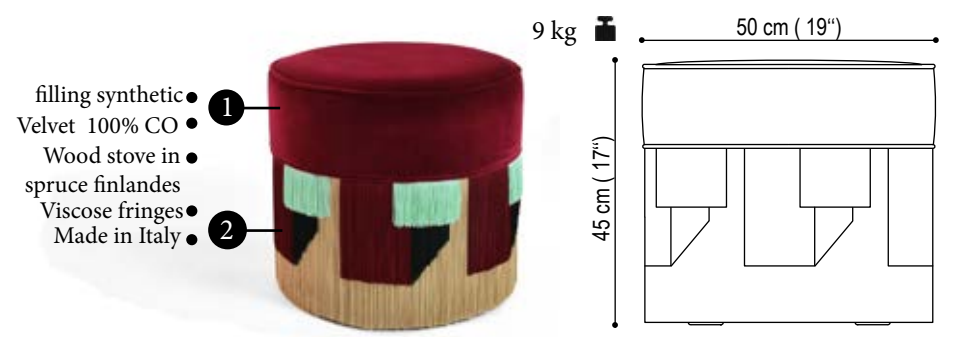

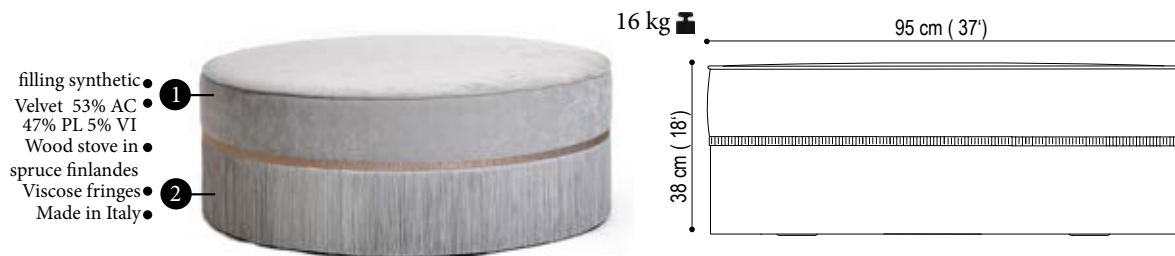
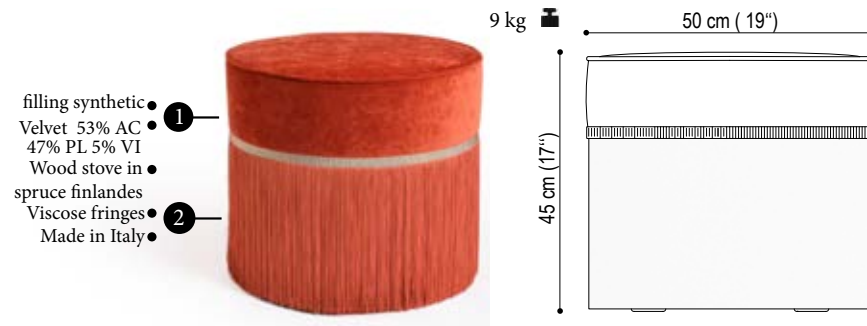
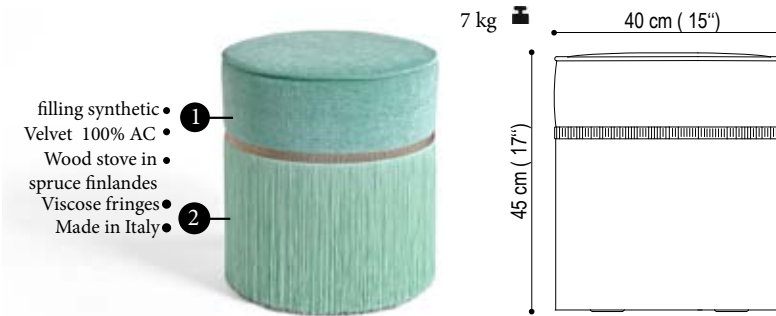
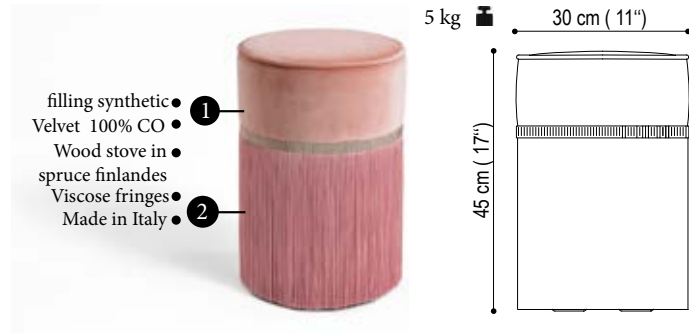



- filling synthetic ●
- Velvet 100% CO ●

- Legs in iron ●
- Viscose fringes ●
- Made in Italy ●

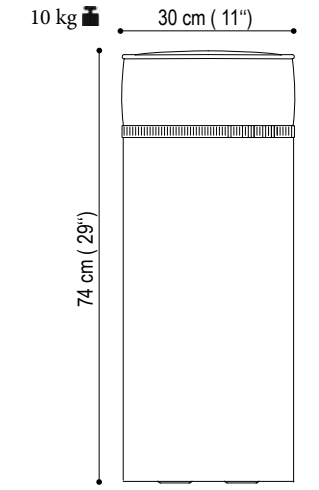
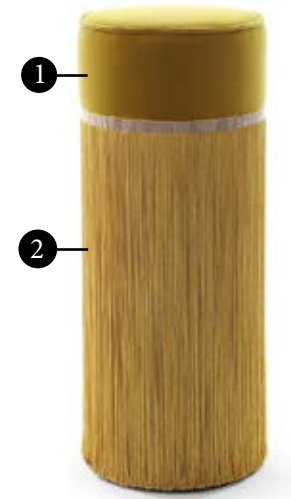

- filling synthetic ●
- Velvet 100% CO ●

- Legs in iron ●
- Viscose fringes ●
- Made in Italy ●

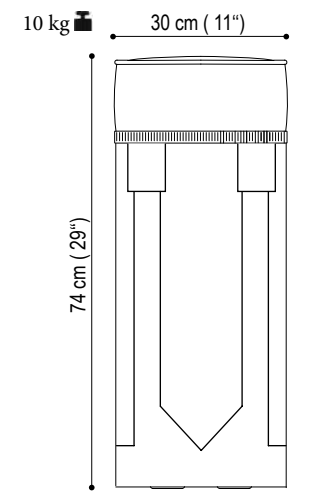
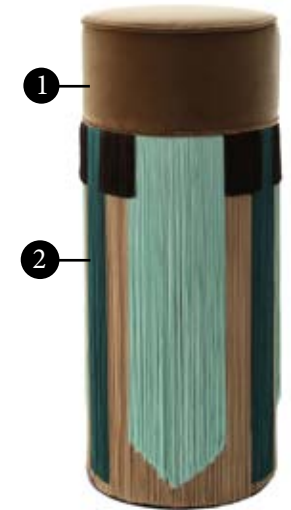

20 kg  93 cm (36") depth 3 cm (1,1")

Mirror ● ①  
Viscose fringes ● ②  
Made in Italy ●

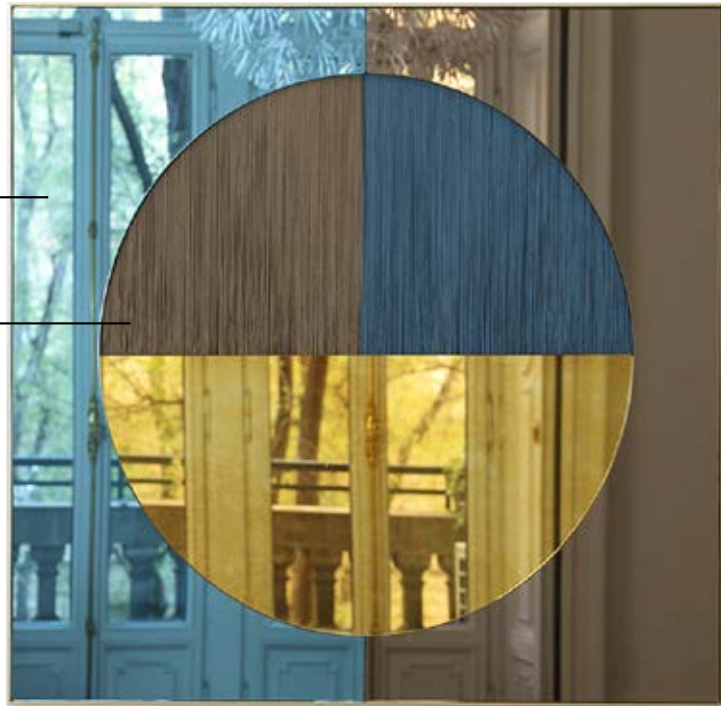

86 cm (33")

20 kg  85cm (33") depth 3 cm (1,1")

Mirror ● ①  
Viscose fringes ● ②  
Made in Italy ●



145 cm (57")



## *Lorenza* **Bozzoli**

Lorenza Bozzoli was born in Milan. She attended the Academy of Brera, and moved to New York to kick-off her career in the fashion field with her first self-produced lines. Upon returning to Milan she soon started working with Elio Fiorucci and companies like Basile, Camper, Sergio Rossi, Plein Sud. Her interest then moved toward the world of interior design, and she started articulating her work through a vast series of collaborations with big brands such as Alessi, Colè, Dedon, Dilmos, Edition, Mingardo, Moooi, Spazio Pontaccio, Slamp, Tato. Lorenza currently lives and works in Milan.

**Lorenza Bozzoli Design**

Address : 54 Foro Buonaparte 20121  
Milano - Italia  
Mob : +39 339 892 7777  
T+39 02-72018776

[www.lorenzabozzoli.com](http://www.lorenzabozzoli.com)  
[lorenza.bozzoli@lorenzabozzoli.com](mailto:lorenza.bozzoli@lorenzabozzoli.com)