

A COLLECTIVE EMBRACE

C—06

saba™

A COLLECTIVE EMBRACE

C—06

saba™

it — Il sentimento che voglio esprimere con questo breve testo, è un senso di gratitudine profonda per le tante persone che hanno creduto, difeso, sostenuto la fragile idea di un sogno.

Il sogno di creare e produrre divani ispirati dal fascino di una parola: libertà. Ho sempre immaginato che le nostre case sono molto simili al teatro: esse sono il luogo dove recitiamo la nostra esistenza e le scenografie che creiamo parlano di noi e raccontano di ciò che ci piace.

La casa è un organismo vivente: come la conchiglia che protegge e custodisce la sua perla, ma che contemporaneamente per nutrirsi lascia filtrare l'acqua del mare, così la nostra casa difende la nostra intimità, ma è aperta ai cambiamenti naturali o desiderati che si manifestano nel corso della vita. Da questi pensieri nasce il sogno che ci ha guidato nel dare sostanza al nostro lavoro: progettare arredi flessibili, arrendevoli alle esigenze attraverso gesti facili e umani per definire nuove esperienze di relax creativo e creare con loro una relazione come in una storia d'amore.

Amelia Pegorin

E non poteva che essere la continua ricerca della bellezza e dell'armonia, la stoffa su cui avvolgere il nostro sogno: materiali, colori, morbidezze, curve inedite, per unire nel progetto le virtù funzionali del design con l'universo della poesia e delle emozioni.

“Siamo fatti della stessa stoffa di cui sono fatti i sogni” scriveva Shakespeare nel quarto atto della Tempesta.

Questa stoffa impalpabile è la nostra umanità più profonda che ci distingue dalle macchine e definisce il lato umano delle nostre case e dei nostri arredi. Le immagini che seguono raccontano questo viaggio ispirato dal sogno di produrre qualcosa di buono, autentico e felice.

en — The feeling I want to express with this short text is one of deep gratitude for the many people who have believed in, defended, and supported the fragile idea of a dream.

The dream of creating and producing sofas inspired by the allure of one word: freedom. I have always imagined our homes to be much like a theater: they are the place where we perform our lives, and the sets we create speak about us and reflect what we love.

The home is a living organism: like a shell that protects and holds its pearl, while still allowing seawater to filter through to nourish itself, our home protects our intimacy, yet remains open to the natural or desired changes that unfold throughout a lifetime. From these reflections a dream was born that shaped and inspired our work: designing flexible furniture, yielding to needs through simple, human gestures in order to define new experiences of creative relaxation and build a relationship with them—just like a love story.

Amelia Pegorin

The continuous pursuit of beauty and harmony became the natural foundation for shaping our dream: materials, colors, softness, and novel curves, to unite in the project the functional virtues of design with the universe of poetry and emotion. *“We are such stuff as dreams are made on,”* wrote Shakespeare in the fourth act of The Tempest.

This intangible fabric is our deepest humanity, which sets us apart from machines and defines the human side of our homes and our furnishings. The images that follow tell the story of this journey, inspired by the dream of creating something good, authentic, and joyful.

Sofas

- 008 ● Vela Piping
- 026 ● Metis
- 046 ● Simposio
- 070 ● Pixel
- 090 ● Ananta
- 110 ● Limes
- 126 New York Suite
- 142 Vela
- 158 ● My Taos
- 174 ● Avant-Après
- 190 ● Pixel Light
- 200 Oltremare
- 212 Gala
- 228 ● Rendez-vous
- 242 Karma
- 248 Up
- 256 Essentiel
- 268 Livingston

Small Sofas

- 276 Geo
- 280 Philo
- 286 Kepi
- 290 New York - dining

Armchairs

- 296 Geo
- 300 Baby Geo
- 304 Ola
- 308 Pan Flute
- 312 Oltremare
- 316 Beauty
- 320 New York - armchair
- 324 New York - bergère
- 326 Sunset - armchair
- 328 Sunset - bergère
- 332 Philo
- 336 Kepi
- 342 Sitar
- 348 Fleur
- 352 Chillout
- 356 Chance
- 360 Amélie
- 364 Bustier
- 368 No Logo Light
- 372 Essentiel

Poufs & Benches

- 378 Beauty - pouf
- 380 Geo - pouf
- 382 Island - pouf
- 384 Cookie - pouf
- 388 Pixel - pouf
- 390 Oltremare - bench
- 394 Pan Flute - bench
- 398 New York Suite - bench

● *Modular System Sofas*

— All products are available for Contract Solutions



Sofas

- 008 ● Vela Piping
- 026 ● Metis
- 046 ● Simposio
- 070 ● Pixel
- 090 ● Ananta
- 110 ● Limes
- 126 New York Suite
- 142 Vela
- 158 ● My Taos
- 174 ● Avant-Après
- 190 ● Pixel Light
- 200 Oltremare
- 212 Gala
- 228 ● Rendez-vous
- 242 Karma
- 248 Up
- 256 Essentiel
- 268 Livingston

design Zanellato / Bortotto
production year 2024

technical data
p. 404

Vela Piping



Vela Piping

Composizione - versione B
382x265 cm
in tessuto Embrace col. 98 C
Poltrona Geo
Tavolini Butter
Tavolino Tres
Tappeto Cime Earth Red

Composition - B version
382x265 cm
in fabric Embrace col. 98 C
Geo armchair
Butter low tables
Tres low table
Cime Earth Red carpet





Composizione - versione B
382x265 cm
in tessuto Embrace col. 98 C
Tappeto Cime Earth Red

Composition - B version
382x265 cm
in fabric Embrace col. 98 C
Cime Earth Red carpet

Vela Piping

Composizione - versione B
441x219 cm
in tessuto Embrace col. 98 C
Tavolini Butter
Tavolino Tres
Tappeto Cime Earth Red

Composition - B version
441x219 cm
in fabric Embrace col. 98 C
Butter low tables
Tres low table
Cime Earth Red carpet



Vela Piping



Composizione - versione B
322x100 cm
in tessuto Charme col. 500
Poltrona Baby Geo
Tavolini Tres
Tappeto Graphic Pink

Composition - B version
322x100 cm
in fabric Charme col. 500
Baby Geo armchair
Tres low tables
Graphic Pink carpet



Vela Piping

Composizione - versione B
322x100 cm
in tessuto Charme col. 500
Poltrona Baby Geo
Tavolini Tres
Tappeto Graphic Pink

Composition - B version
322x100 cm
in fabric Charme col. 500
Baby Geo armchair
Tres low tables
Graphic Pink carpet



Composizione - versione B
322x158 cm
in tessuto Charme col. 500
Tavolini Teatro Magico
Tappeto Graphic Pink

Composition - B version
322x158 cm
in fabric Charme col. 500
Teatro Magico low tables
Graphic Pink carpet



Vela Piping

Composizione - versione B
322x158 cm
in tessuto Charme col. 500
Tavolini Teatro Magico
Tappeto Graphic Pink

Composition - B version
322x158 cm
in fabric Charme col. 500
Teatro Magico low tables
Graphic Pink carpet





Composizione - versione A / Composition - A version
L 278 x P 100 x H 74 cm



Composizione - versione B / Composition - B version
L 322 x P 100 x H 74 cm

design Nicola Pavan
production year 2023

technical data
p. 406

Metis



Metis

Composizione 449x183 cm
in tessuto Metis col. 01
Poltrona Pan Flute
Tavolini Teatro Magico
Tavolino Più

Composition 449x183 cm
in fabric Metis col. 01
Pan Flute armchair
Teatro Magico low tables
Più low table



Composizione 449×183 cm
in tessuto Metis col. 01
Poltrona Pan Flute
Tavolini Teatro Magico
Tavolino Più
Tavolo Teatro Magico
Sedie Isabelle

Composition 449×183 cm
in fabric Metis col. 01
Pan Flute armchair
Teatro Magico low tables
Più low table
Teatro Magico table
Isabelle chairs





Composizione 359×183 cm
in tessuto Metis col. 01
Tavolino Teatro Magico
Tavolino Più

Composition 359×183 cm
in fabric Metis col. 01
Teatro Magico low table
Più low table



Composizione 359×183 cm
in tessuto Metis col. 01
Poltrona Pan Flute
Tavolini Teatro Magico
Tavolino Più

Composition 359×183 cm
in fabric Metis col. 01
Pan Flute armchair
Teatro Magico low tables
Più low table



Metis

Composizione 270x182 cm
in tessuto Metis col. 07
Poltrona Pan Flute
Tavolini Hexa

Composition 270x182 cm
in fabric Metis col. 07
Pan Flute armchair
Hexa low tables



Composizione 270x182 cm
in tessuto Metis col. 07

Composition 270x182 cm
in fabric Metis col. 07





Composizione 183x183 cm
in tessuto Lario col. 14
Tavolino Teatro Magico

Composition 183x183 cm
in fabric Lario col. 14
Teatro Magico low table





Composizione 183x183 cm
in tessuto Lario col. 14
Tavolino Teatro Magico

Composition 183x183 cm
in fabric Lario col. 14
Teatro Magico low table



Composizione 360×95 cm
in tessuto Metis col. 01
Tavolino Teatro Magico
Pouf Geo

Composition 360×95 cm
in fabric Metis col. 01
Teatro Magico low table
Geo pouf



Simposio



Simposio

Composizione 338x122 cm
ed elemento 94x100 cm
in tessuto Simposio col. 05/3
Pouf Beauty
Tavolini Ring

Composition 338x122 cm
and unit 94x100 cm
in fabric Simposio col. 05/3
Beauty pouf
Ring low tables





Composizione 338x122 cm
e elemento 94x100 cm
in tessuto Simposio col. 05/3
Tavolino Ring

Composition 338x122 cm
and unit 94x100 cm
in fabric Simposio col. 05/3
Ring low table

Simposio

Composizione 432x216 cm
in tessuto Simposio col. 09/8
Tavolini Butter
Tappeto Cime Natural
Tavolo Teatro Magico
Sedie Ola

Composition 432x216 cm
in fabric Simposio col. 09/8
Butter low tables
Cime Natural carpet
Teatro Magico table
Ola chairs



Composizione 432×216 cm
 in tessuto Simposio col. 09/8
 Tavolini Butter
 Tappeto Cime Natural

Composition 432×216 cm
 in fabric Simposio col. 09/8
 Butter low tables
 Cime Natural carpet

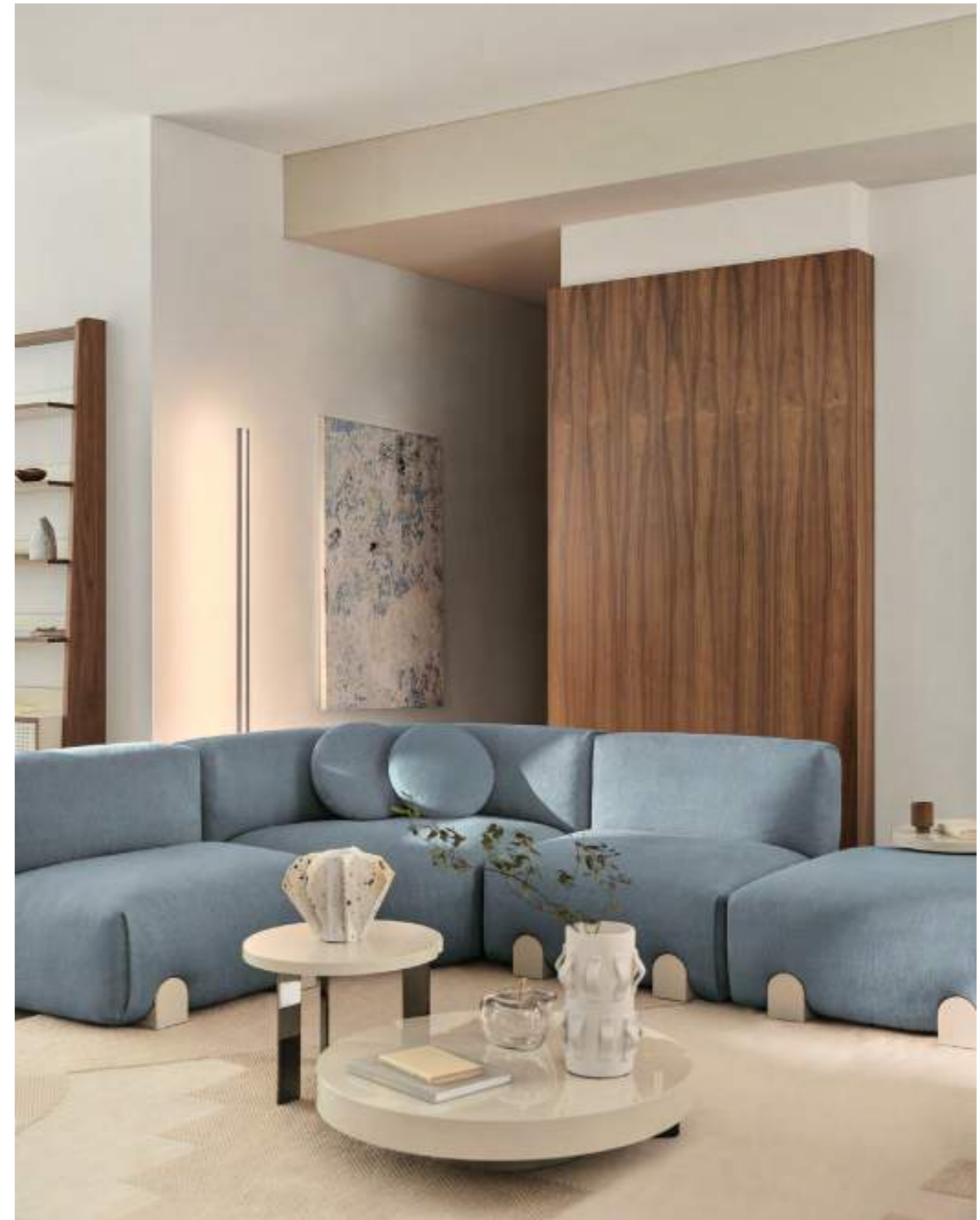



Composizioni 404x322 cm
e 310x122 cm
in tessuto Curly col. 14
Pouf Beauty
Tavolini Butter

Compositions 404x322 cm
and 310x122 cm
in fabric Curly col. 14
Beauty pouf
Butter low tables



Elemento in tessuto Curly col. 14

Unit in fabric Curly col. 14

Simposio



Composizione 404x216 cm
in tessuto Curly col. 14
Poltrona Beauty
Pouf Beauty
Tavolino Butter

Composition 404x216 cm
in fabric Curly col. 14
Beauty armchair
Beauty pouf
Butter low table





Composizione 400x100 cm
in tessuto Simposio col. 07/7
Poltrona Pan Flute
Tavolini Tres

Composition 400x100 cm
in fabric Simposio col. 07/7
Pan Flute armchair
Tres low tables

Simposio



Composizione 400x100 cm
in tessuto Simposio col. 07/7
Tavolini Tres

Composition 400x100 cm
in fabric Simposio col. 07/7
Tres low tables





Elementi 162×100 cm
e 94×100 cm
in tessuto Curly col. 14
Tavolini Tres

Units 162×100 cm
and 94×100 cm
in fabric Curly col. 14
Tres low tables

Elemento 94×100 cm
in tessuto Curly col. 14
Tavolino Tres

Unit 94×100 cm
in fabric Curly col. 14
Tres low table



design Sergio Bicego
production year 2010
restyling 2014

technical data
p. 410

Pixel



Composizione 446x204 cm
in tessuto Creta col. 2A
Tavolino Hexa
Tavolino Più
Poltrona Amélie

Composition 446x204 cm
in fabric Creta col. 2A
Hexa low table
Più low table
Amélie armchair





Composizione 446x204 cm
in tessuto Creta col. 2A

Composition 446x204 cm
in fabric Creta col. 2A





Composizione 366x162 cm
in tessuto Creta col. 2A
Tavolino Hexa
Tavolini Più

Composition 366x162 cm
in fabric Creta col. 2A
Hexa low table
Più low tables

406 x 122 cm **Composizione / Composition A**

Elementi / Elements:
 2 Basi / Bases 122x82 cm
 1 Base / Base 122x122 cm
 3 Schienali-Braccioli / Back-Armrests 122 cm H 64 cm
 2 Cuscini schiena / Back cushions 66x66 cm
 1 Cuscino arredo / Throw cushion 45x45 cm

**306 x 132 cm** **Composizione / Composition B**

Elementi / Elements:
 1 Base / Base 82x82 cm
 2 Basi / Bases 122x82 cm
 3 Schienali / Backrests 82 cm
 1 Schienale / Backrest 122 cm
 2 Cuscini schiena / Back cushions 66x66 cm
 1 Cuscino arredo / Throw cushion 45x45 cm

**296 x 254 cm** **Composizione / Composition C**

Elementi / Elements:
 1 Base / Base 164x82 cm
 2 Basi / Bases 122x122 cm
 3 Schienali / Backrests 82 cm
 2 Cuscini schiena / Back cushions 66x66 cm
 1 Cuscino arredo / Throw cushion 45x45 cm
 1 Rullo / Roll 23 cm

**284 x 256 cm** **Composizione / Composition D**

Elementi / Elements:
 2 Basi / Bases 122x82 cm
 1 Base / Base 164x82 cm
 1 Schienale / Backrest 82 cm
 1 Schienale / Backrest 122 cm
 1 Schienale-Bracciolo / Back-Armrest 82 cm H 52 cm
 1 Schienale-Bracciolo / Back-Armrest 164 cm H 52 cm
 2 Cuscini schiena / Back cushions 66x66 cm
 1 Cuscino schiena 66x66 cm con rullo 12 cm / Back cushion 66x66 cm with roll 12 cm
 3 Cuscini arredo / Throw cushions 45x45 cm



Composizione 294x132 cm
in tessuto Patchwork
(Creta col. 2A / Darwin col. 07
/ Teddy col. 01/1
/ Avant-Après col. 56)
Tavolino Hexa
Pouf Geo

Composition 294x132 cm
in Patchwork fabric
(Creta col. 2A / Darwin col. 07
/ Teddy col. 01/1
/ Avant-Après col. 56)
Hexa low table
Geo pouf



Composizione 294x132 cm
in tessuto Patchwork
(Creta col. 2A / Darwin col. 07
/ Teddy col. 01/1
/ Avant-Après col. 56)
Tavolino Hexa

Composition 294x132 cm
in Patchwork fabric
(Creta col. 2A / Darwin col. 07
/ Teddy col. 01/1
/ Avant-Après col. 56)
Hexa low table



Composizione E 244x122 cm
in tessuto Creta col. 2A

Composition E 244x122 cm
in fabric Creta col. 2A



Composizione F 284x284 cm
in tessuto Creta col. 2A

Composition F 284x284 cm
in fabric Creta col. 2A



Composizione 418x264 cm
in tessuto F555 col. 03
Tavolini Più
Tavolino e consolle Hexa
Pouf Geo

Composition 418x264 cm
in fabric F555 col. 03
Più low tables
Hexa low table and console
Geo pouf





Composizione 418x264 cm
in tessuto F555 col. 03
Tavolino Più
Tavolino Hexa

Composition 418x264 cm
in fabric F555 col. 03
Più low table
Hexa low table



design Sergio Bicego
production year 2000
restyling 2016/2024

technical data
p. 414

Ananta



Ananta

Composizione 395x340 cm
in tessuto Embrace col. 04
Tavolino in rovere chiaro
80x35x H36 cm
Poltrona Pan Flute
Tavolini Ring
Tappeto Cime Colors

Composition 395x340 cm
in fabric Embrace col. 04
Low table in light durmast
80x35x H36 cm
Pan Flute armchair
Ring low tables
Cime Colors carpet





Composizione 420x145 cm
in tessuto Embrace col. 04
Tavolino in rovere chiaro
80x35x H47 cm
Tavolini Ring
Tappeto Cime Colors

Composition 420x145 cm
in fabric Embrace col. 04
Low table in light durmast
80x35x H47 cm
Ring low tables
Cime Colors carpet





Composizione 350x185 cm
in tessuto Curly col. 14
Tavolino Butter
Tavolini Teatro Magico

Composition 350x185 cm
in fabric Curly col. 14
Butter low table
Teatro Magico low tables



Composizione 350x185 cm
 in tessuto Curly col. 14
 Tavolino Butter
 Tavolini Teatro Magico

Composition 350x185 cm
 in fabric Curly col. 14
 Butter low table
 Teatro Magico low tables

Composizione 350x185 cm
in tessuto Curly col. 14
Tavolino Butter

Composition 350x185 cm
in fabric Curly col. 14
Butter low table



Elementi / Elements

- 1 Base / Base 160×80 cm
- 1 Base / Base 200×80 cm
- 1 Schienale / Backrest 80 cm
- 1 Schienale / Backrest 120 cm
- 2 Schienali angolari / Corner backrests 105×105 cm
- 3 Cuscini schiena con rullo / Back cushions with roll 70 cm
- 1 Tavolino / Low table 50×35 cm



330 x 185 cm

Composizione / Composition A

- 1 Base / Base 160×80 cm
- 1 Base / Base 200×80 cm
- 1 Schienale / Backrest 80 cm
- 1 Schienale / Backrest 120 cm
- 2 Schienali angolari / Corner backrests 105×105 cm
- 3 Cuscini schiena con rullo / Back cushions with roll 70 cm
- 1 Tavolino / Low table 50×35 cm



290 x 250 cm

Composizione / Composition B

- 1 Base / Base 160×80 cm
- 1 Base / Base 200×80 cm
- 1 Schienale / Backrest 80 cm
- 1 Schienale / Backrest 120 cm
- 2 Schienali angolari / Corner backrests 105×105 cm
- 3 Cuscini schiena con rullo / Back cushions with roll 70 cm
- 1 Tavolino / Low table 50×35 cm

**Composizione / Composition C****Divani / Sofas 250 x 105 cm - 185 x 105 cm**

- 1 Base / Base 160×80 cm
- 1 Base / Base 200×80 cm
- 1 Schienale / Backrest 80 cm
- 1 Schienale / Backrest 120 cm
- 2 Schienali angolari / Corner backrests 105×105 cm
- 3 Cuscini schiena con rullo / Back cushions with roll 70 cm
- 1 Tavolino / Low table 50×35 cm



Ananta

Composizione 350x105 cm
in tessuto Plain col. 01
Poltrona Kepi
Tavolino Più
Tavolino Ring
Pouf Geo

Composition 350x105 cm
in fabric Plain col. 01
Kepi armchair
Più low table
Ring low table
Geo pouf



Composizione 350×105 cm
in tessuto Plain col. 01
Poltrona Kepi
Tavolino Più
Tavolino Ring

Composition 350×105 cm
in fabric Plain col. 01
Kepi armchair
Più low table
Ring low table



Ananta

Composizione 350x185 cm
in tessuto Plain col. 01
Tavolini in cuoio
80x35 cm e 50x35 cm
Tavolino Hexa
Pouf Cookie

Composition 350x185 cm
in fabric Plain col. 01
Low tables in leather
80x35 cm and 50x35 cm
Hexa low table
Cookie pouf



design Sergio Bicego
production year 2002
restyling 2019/2025

technical data
p. 416

Limes



Composizione 375x163 cm
in tessuto Embrace col. 69
Tavolini Butter

Composition 375x163 cm
in fabric Embrace col. 69
Butter low tables



Composizione 371x163 cm
in tessuto Embrace col. 69
Tavolini Tres

Composition 371x163 cm
in fabric Embrace col. 69
Tres low tables





Composizione 375x163 cm
in tessuto Embrace col. 69
Tavolini Butter

Composition 375x163 cm
in fabric Embrace col. 69
Butter low tables





Composizione 371x163 cm
in tessuto Embrace col. 69

Composition 371x163 cm
in fabric Embrace col. 69

Composizione 316x255 cm
in tessuto Charme col. 100
Tavolini Ring

Composition 316x255 cm
in fabric Charme col. 100
Ring low tables





Composizione 316x255 cm
in tessuto Charmé col. 100
Tavolini Ring

Composition 316x255 cm
in fabric Charmé col. 100
Ring low tables



design Sergio Bicego
production year 2015

technical data
p. 418

New York Suite



New York Suite

Divani 190×100 cm
e 230×100 cm
in tessuto Lario col. 1101
Tavolini Hexa
Tavolino Ring

Sofas 190×100 cm
and 230×100 cm
in fabric Lario col. 1101
Hexa low tables
Ring low table



Divani 230x100 cm
in tessuto Lario col. 1101
Tavolini Hexa
Tavolino Ring

Sofas 230x100 cm
in fabric Lario col. 1101
Hexa low tables
Ring low table





Divano 230x100 cm
in tessuto Lario col. 1101
Tavolini Hexa

Sofa 230x100 cm
in fabric Lario col. 1101
Hexa low tables





Composizione 335x165 cm
in tessuto Sweet Velvet col. 62
Tavolini Più
Consolle Hexa

Composition 335x165 cm
in fabric Sweet Velvet col. 62
Più low tables
Hexa console



Divano 230x100 cm
e pouf 140x65 cm
in tessuto Lario col. 1403
Tavolino Haiku

Sofa 230x100 cm
and pouf 140x65 cm
in fabric Lario col. 1403
Haiku low table





Poltrona lounge 155x130 cm
in tessuto Teddy col. 05/6
Tavolino Hexa

Lounge armchair 155x130 cm
in fabric Teddy col. 05/6
Hexa low table

design Zanellato / Bortotto
production year 2023

technical data
p. 404

Vela



Divani 220x100 cm
in tessuto Vela col. 17
Poltrona Baby Geo
Tavolini Teatro Magico

Sofas 220x100 cm
in fabric Vela col. 17
Baby Geo armchair
Teatro Magico low tables





Divano 220×100 cm
in tessuto Vela col. 17
Tavolino Teatro Magico

Sofa 220×100 cm
in fabric Vela col. 17
Teatro Magico low table

Vela

Divani 220×100 cm
in tessuto Vela col. 17
Panca Pan Flute
Tavolini Teatro Magico

Sofas 220×100 cm
in fabric Vela col. 17
Pan Flute bench
Teatro Magico low tables



Divano 220×100 cm
in tessuto Vela col. 17
Panca Pan Flute

Sofa 220×100 cm
in fabric Vela col. 17
Pan Flute bench





Divano 190x100 cm
in tessuto Vela col. 431
Tavolino Teo
Tavolo Teatro Magico
Sedie New York

Sofa 190x100 cm
in fabric Vela col. 431
Teo low table
Teatro Magico table
New York chairs

Divano 190×100 cm
in tessuto Vela col. 431
Tavolino Teo

Sofa 190×100 cm
in fabric Vela col. 431
Teo low table





Divano 190x100 cm
in tessuto Vela col. 431
Tavolino Teo

Sofa 190x100 cm
in fabric Vela col. 431
Teo low table

design Sergio Bicego
production year 1999
restyling 2018

technical data
p. 420

My Taos



My Taos

Composizione 446x210 cm
in tessuto Dickinson col. 14
Tavolino in noce
canaletto 105x28 cm
Tavolini Più

Composition 446x210 cm
in fabric Dickinson col. 14
Low table in walnut
veneer 105x28 cm
Più low tables



Composizione 366×260 cm
in tessuto Seventy col. 90
Tavolino in noce
canaletto 105×28 cm
Tavolini Più

Composition 366×260 cm
in fabric Seventy col. 90
Low table in walnut
veneer 105×28 cm
Più low tables



Composizione 366×260 cm
in tessuto Seventy col. 90
Tavolino in noce
canaletto 105×28 cm

Composition 366×260 cm
in fabric Seventy col. 90
Low table in walnut
veneer 105×28 cm





Divano 260x130 cm
in tessuto Avant-Après col. 24
Tavolino Più
Tavolino Leyva

Sofa 260x130 cm
in fabric Avant-Après col. 24
Più low table
Leyva low table



411 x 130 cm **Composizione / Composition A**

Elementi
/ Elements:

- 1 Base / Base 130x130 cm
- 1 Centrale / Central unit 85x105 cm
- 1 Centrale / Central unit 170x105 cm
- 1 Bracciolo DX / Right armrest 26 cm
- 1 Cuscino schiena / Back cushion 85 cm
- 1 Rullo / Roll 23 cm

**341 x 341 cm** **Composizione / Composition B**

Elementi
/ Elements:

- 1 Base / Base 210x105 cm
- 1 Centrale / Central unit 105x105 cm
- 1 Centrale / Central unit 210x105 cm
- 1 Bracciolo SX / Left armrest 26 cm
- 1 Bracciolo DX / Right armrest 26 cm
- 1 Cuscino schiena / Back cushion 85 cm
- 1 Rullo / Roll 23 cm



Note
/ Notes:

La seduta degli elementi centrali può **scorrere** in avanti
/ Central unit seating can **slide** forward

326 x 130 cm **Composizione / Composition C**

Elementi
/ Elements:

- 1 Base / Base 130x130 cm
- 1 Centrale / Central unit 170x105 cm
- 1 Bracciolo DX / Right armrest 26 cm
- 1 Cuscino schiena / Back cushion 85 cm
- 1 Rullo / Roll 23 cm
- 1 Tavolino / Low table 105x28 cm



Note
/ Notes:

La seduta degli elementi centrali può **scorrere** in avanti
/ Central unit seating can **slide** forward



Composizione My Taos
411x130 cm
in tessuto Darwin col. 1633
Poltrona Kepi
Pouf Cookie
Tavolini Più / Teo

Composition My Taos
411x130 cm
in fabric Darwin col. 1633
Kepi armchair
Cookie pouf
Più / Teo low tables





design Sergio Bicego
production year 2017

technical data
p. 422

Avant-Après

Composizione 356×253 cm
in tessuto Avant-Après col. 18
Tavolino in noce
canaletto 35×38 cm
Poltrona Baby Geo
Tavolino Haiku

Composition 356×253 cm
in fabric Avant-Après col. 18
Low table in walnut
veneer 35×38 cm
Baby Geo armchair
Haiku low table





Composizione 356×253 cm
in tessuto Avant-Après col. 18
Tavolino in noce
canaletto 35×38 cm

Composition 356×253 cm
in fabric Avant-Après col. 18
Low table in walnut
veneer 35×38 cm



Composizione 346x93 cm
in tessuto Avant-Après col. 18
Tavolino in noce
canaletto 70x33 cm
Tavolino Ring

Composition 346x93 cm
in fabric Avant-Après col. 18
Low table in walnut
veneer 70x33 cm
Ring low table





Composizione 346x93 cm
in tessuto Avant-Après col. 18
Tavolino in noce
canaletto 35x38 cm

Composition 346x93 cm
in fabric Avant-Après col. 18
Low table in walnut
veneer 35x38 cm



293 x 236 cm **Composizione / Composition A**

- Elementi / Elements:
- 2 Basi / Bases 200x80 cm
 - 5 Schienali / Backrests 80 cm
 - 1 Bracciolo / Armrest
 - 1 Cuscino schiena / Back cushion 62 cm
 - 4 Cuscini schiena / Back cushions 80 cm
 - 1 Cuscino bracciolo / Armrest cushion
 - 1 Tavolino / Low table 35x38 cm



293 x 236 cm **Composizione / Composition B**

- Elementi / Elements:
- 1 Base / Base 200x80 cm
 - 1 Base con bracciolo imbottito / Base with padded armrest 200x80 cm
 - 5 Schienali / Backrests 80 cm
 - 1 Bracciolo / Armrest
 - 1 Cuscino schiena / Back cushion 62 cm
 - 4 Cuscini schiena / Back cushions 80 cm
 - 1 Cuscino bracciolo / Armrest cushion
 - 1 Tavolino / Low table 35x38 cm



316 x 106 cm **Composizione / Composition C**

- Elementi / Elements:
- 1 Base / Base 120x80 cm
 - 1 Base / Base 160x80 cm
 - 3 Schienali / Backrests 80 cm
 - 1 Bracciolo / Armrest
 - 1 Cuscino schiena / Back cushion 62 cm
 - 2 Cuscini schiena / Back cushions 80 cm
 - 1 Cuscino bracciolo / Armrest cushion
 - 1 Tavolino / Low table 35x38 cm



Divano 236x93 cm
in tessuto
Avant-Après col. 02
Tavolino in noce
canaletto 35x38 cm
Tavolino Haiku
Pouf Geo

Sofa 236x93 cm
in fabric
Avant-Après col. 02
Low table in walnut
veneer 35x38 cm
Haiku low table
Geo pouf



Divano 236×93 cm
in tessuto
Avant-Après col. 02
Tavolino in noce
canaletto 35×38 cm
Tavolino Haiku

Sofa 236×93 cm
in fabric
Avant-Après col. 02
Low table in walnut
veneer 35×38 cm
Haiku low table



design Sergio Bicego
production year 2020/2022

technical data
p. 424

Pixel Light



Pixel-Light

Composizione 164x122 cm
in tessuto Simple col. 15
Poltrona Sunset
Tavolini Hexa
Pouf Sitar

Composition 164x122 cm
in fabric Simple col. 15
Sunset armchair
Hexa low tables
Sitar pouf



Composizione 164x122 cm
in tessuto Simple col. 15

Composition 164x122 cm
in fabric Simple col. 15





Composizione 336x254 cm
tessuto suggerito Frame col. 08
Tavolino Geo
Tavolino e Consolle Hexa
Tavolino Più
Pouf Island

Composition 336x254 cm
fabric suggested Frame col. 08
Geo low table
Hexa low table and console
Più low table
Island pouf



Composizione 336×254 cm
tessuto suggerito Frame col. 08
e fasce in pelle Seta
col. Brandy
Tavolino Hexa

Composition 336×254 cm
fabric suggested Frame col. 08
and bands in leather Seta
col. Brandy
Hexa low table



design Saba Italia + A. Marras
production year 2020

technical data
p. 426

Oltremare



Divano 225x83 cm
in tessuto Frame col. 15
Tavolini Hexa
Tavolino Più

Sofa 225x83 cm
in fabric Frame col. 15
Hexa low tables
Più low table





Divano 225×83 cm
in tessuto Frame col. 15
Tavolino Hexa

Sofa 225×83 cm
in fabric Frame col. 15
Hexa low table

Divano 225x83 cm
in tessuto Seventy col. 01
Tavolini Più
Tavolino Leyva

Sofa 225x83 cm
in fabric Seventy col. 01
Più low tables
Leyva low table





Divano 225x83 cm
in tessuto Seventy col. 01
Tavolino Più
Tavolino Leyva

Sofa 225x83 cm
in fabric Seventy col. 01
Più low table
Leyva low table



Divano 225x83 cm
in tessuto Seventy col. 01
Tavolino Più

Sofa 225x83 cm
in fabric Seventy col. 01
Più low table





design Cristina Celestino
production year 2021

technical data
p. 428

Gala

Divano 244×126 cm
in tessuto Gala col. 06
Poltrona Sitar
Pouf Island

Sofa 244×126 cm
in fabric Gala col. 06
Sitar armchair
Island pouf



Divano 244x126 cm
in tessuto Gala col. 06

Sofa 244x126 cm
in fabric Gala col. 06



Divano 170x126 cm
in tessuto Gala col. 61
Pouf Cookie

Sofa 170x126 cm
in fabric Gala col. 61
Cookie pouf

Divano 170x126 cm
in tessuto Gala col. 61
Tavolino Ring
Pouf Cookie

Sofa 170x126 cm
in fabric Gala col. 61
Ring low table
Cookie pouf





Divano 244×126 cm
in tessuto
Sweet Velvet col. 125
Tavolini Leyva

Sofa 244×126 cm
in fabric
Sweet Velvet col. 125
Leyva low tables

Divano 244x203 cm
Poltrone Chance
Tavolino Hexa
Tavolino Più

Sofa 244x203 cm
Chance armchairs
Hexa low table
Più low table





Divano 244x126 cm
in tessuto Gala col. 81
Poltrona Oltremare
Pouf Geo
Tavolino Più

Sofa 244x126 cm
in fabric Gala col. 81
Oltremare armchair
Geo pouf
Più low table



design Sergio Bicego
production year 2019

technical data
p. 430

Rendez-vous





Composizione 234x82 cm
in tessuto Teddy col. 07/24

Composition 234x82 cm
in fabric Teddy col. 07/24



Composizione 292x82 cm
in tessuto Sole CS col. 403
Composizione 246x94 cm
in tessuto X076 col. 22
Poltrona Geo
Poltrona Ola
Tavolini Più

Composition 292x82 cm
in fabric Sole CS col. 403
Composition 246x94 cm
in fabric X076 col. 22
Geo armchair
Ola armchair
Più low tables





Composizione 246x94 cm
in tessuto X076 col. 22
Composizione 140x70 cm
in tessuto Sole CS col. 403
Poltrona Chillout
Tavolino Hexa

Composition 246x94 cm
in fabric X076 col. 22
Composition 140x70 cm
in fabric Sole CS col. 403
Chillout armchair
Hexa low table





Composizioni
188x94 cm
in tessuto Violet col. 08

Compositions
188x94 cm
in fabric Violet col. 08

292 x 82 cm **Composizione / Composition A**

Elementi
/ Elements:

- 1 Angolare DX / Right corner unit 82x82 cm
- 1 Ripiano / Shelf unit 70x70 cm
- 2 Centrali / Central units 70x82 cm
- 1 Cuscino arredo con fascia / Throw cushion with band Ø 47 cm

**292 x 222 cm** **Composizione / Composition B**

Elementi
/ Elements:

- 1 Ripiano / Shelf unit 35x70 cm
- 1 Centrale / Central unit 105x82 cm
- 1 Ripiano / Shelf unit 70x70 cm
- 1 Pouf 70x70 cm
- 2 Centrali / Central units 70x82 cm
- 1 Cuscino arredo con fascia / Throw cushion with band Ø 47 cm

**258 x 94 cm** **Composizione / Composition C**

Elementi
/ Elements:

- 1 Angolare curvo SX / Left curved corner unit 94x94 cm
- 1 Centrale curvo / Central curved unit 70x94 cm
- 1 Angolare curvo DX / Right curved corner unit 94x94 cm
- 3 Cuscini schiena / Back cushions 60x33 cm

**258 x 234 cm** **Composizione / Composition D**

Elementi
/ Elements:

- 1 Pouf 70x70 cm
- 1 Centrale curvo / Central curved unit 70x94 cm
- 1 Angolare curvo SX / Left curved corner unit 94x94 cm
- 1 Centrale / Central unit 70x82 cm
- 1 Angolare curvo DX / Right curved corner unit 94x94 cm
- 2 Cuscini schiena / Back cushions 60x33 cm
- 1 Cuscino arredo con fascia / Throw cushion with band Ø 47 cm



design Sergio Bicego
production year 1999
restyling 2013

technical data
p. 427

Karma





Divano 300x110 cm
in tessuto Simposio 01/2
Poltrona Chillout
Tavolini Ring
Tavolino Teo
Tappeto Cime Colors

Sofa 300x110 cm
in fabric Simposio 01/2
Chillout armchair
Ring low tables
Teo low table
Cime Colors carpet



Divano 300×110 cm
in tessuto Simposio 01/2
Tavolini Ring
Tappeto Cime Colors

Sofa 300×110 cm
in fabric Simposio 01/2
Ring low tables
Cime Colors carpet



design Giuseppe Viganò
production year 2008

technical data
p. 432

Up

Composizione 360x170 cm
in pelle Natural col. Creta
Tavolini Più
Pouf Geo

Composition 360x170 cm
in leather Natural col. Creta
Più low tables
Geo pouf





Composizione 360x170 cm
in pelle Natural col. Creta

Composition 360x170 cm
in leather Natural col. Creta



Divano 260x100 cm
tessuto suggerito Charme col. 605
Tavolino Leyva

Sofa 260x100 cm
fabric suggested Charme col. 605
Leyva low table

design Sergio Bicego
production year 2016

technical data
p. 434

Essentiel



Composizione 275x160 cm
tessuto suggerito Lima col. 21
poltrona Chance
Tavolini Più
Pouf Geo

Composition 275x160 cm
fabric suggested Lima col. 21
Chance armchair
Più low tables
Geo pouf



Essentiel

Divano 250×95 cm
in pelle Ocean col. 14
Tavolino Hexa
Tavolini Leyva
Pouf Island

Sofa 250×95 cm
in leather Ocean col. 14
Hexa low table
Leyva low tables
Island pouf



Divano 250×95 cm
in pelle Ocean col. 14
Pouf Island

Sofa 250×95 cm
in leather Ocean col. 14
Island pouf



Divano 220×95 cm
tessuto suggerito Lima col. 20
Poltrona Baby Geo
Tavolino Più
Tavolino Ring

Sofa 220×95 cm
fabric suggested Lima col. 20
Baby Geo armchair
Più low table
Ring low table





Divano 220x95 cm
tessuto suggerito Lima col. 20

Sofa 220x95 cm
fabric suggested Lima col. 20

design Giuseppe Viganò
production year 2009

technical data
p. 436

Livingston



Composizione 326x102 cm
in tessuto Sweet Velvet col. 116
Tavolino Più

Composition 326x102 cm
in fabric Sweet Velvet col. 116
Più low table





Composizione 326x102 cm
in tessuto Sweet Velvet col. 116

Composition 326x102 cm
in fabric Sweet Velvet col. 116



Small Sofas

- 276 Geo
- 280 Philo
- 286 Kepi
- 290 New York - dining

design Paolo Grasselli
production year 2018

technical data
p. 438

Geo



Divanetto 153x84 cm
in tessuto
Sweet Velvet col. 24
Poltrona 90x82 cm
e pouf 60 cm
in tessuto J'Adore col. 08
Tavolini Leyva
Tavolino Hexa

Small sofa 153x84 cm
in fabric
Sweet Velvet col. 24
Armchair 90x82 cm
and pouf 60 cm
in fabric J'Adore col. 08
Leyva low tables
Hexa low table



design Marco Zito
production year 2019

technical data
p. 439

Philo





Divanetto 3 posti 216x70 cm
in tessuto Sole CS col. 406
Divanetto 2 posti 160x70 cm
in tessuto Sole CS col. 407
Poltrone 83x70 cm
in tessuto Seventy col. 90
Pouf Geo
Tavolino Hexa

Small sofa 3 seating 216x70 cm
in fabric Sole CS col. 406
Small sofa 2 seating 160x70 cm
in fabric Sole CS col. 407
Armchairs 83x70 cm
in fabric Seventy col. 90
Geo pouf
Hexa low table





Divanetto 2 posti 160x70 cm
in tessuto Sole CS col. 407
Pouf Geo

Small sofa 2 seating 160x70 cm
in fabric Sole CS col. 407
Geo pouf

design Emilio Nanni
production year 2018

technical data
p. 440

Kepi



Divanetto 160x80 cm
in tessuto Saint Moritz col. 148
Poltrona 90x78 cm
in tessuto Diplo col. 24
Pouf 65x44 cm
in tessuto Vegas Velvet col. 57
Tavolino Più

Small sofa 160x80 cm
in fabric Saint Moritz col. 148
Armchair 90x78 cm
in fabric Diplo col. 24
Pouf 65x44 cm
in fabric Vegas Velvet col. 57
Più low table



design Sergio Bicego
production year 2019

technical data
p. 418

New York dining





Seduta 143x54 cm
in tessuto Sweet Velvet col. 62
Tavolino Hexa

Seating 143x54 cm
in fabric Sweet Velvet col. 62
Hexa low table



Armchairs

- 296 Geo
- 300 Baby Geo
- 304 Ola
- 308 Pan Flute
- 312 Oltremare
- 316 Beauty
- 320 New York - armchair
- 324 New York - bergère
- 326 Sunset - armchair
- 328 Sunset - bergère
- 332 Philo
- 336 Kepi
- 342 Sitar
- 348 Fleur
- 352 Chillout
- 356 Chance
- 360 Amélie
- 364 Bustier
- 368 No Logo Light
- 372 Essentiel

design Paolo Grasselli
production year 2018

technical data
p. 438

Geo



Poltrona 90×82 cm
e pouf 60 cm
in tessuto J'Adore col. 08

Armchair 90×82 cm
and pouf 60 cm
in fabric J'Adore col. 08



design Paolo Grasselli
production year 2019

technical data
p. 438

Baby Geo



Poltrona 75x80 cm
in tessuto
Catch Me col. Caccia Chioma
e Vegas Velvet col. 33
Poltrona 75x80 cm
in tessuto
Sweet Velvet col. 144
Tavolini Più
Tavolino Leyva
Pouf Geo

Armchair 75x80 cm
in fabric
Catch Me col. Caccia Chioma
and Vegas Velvet col. 33
Armchair 75x80 cm
in fabric
Sweet Velvet col. 144
Più low tables
Leyva low table
Geo pouf



Poltrona 75x80 cm
in tessuto 1807 col. 01
versione trapuntata
Tavolino Butter
Tappeto Cime Colors

Armchair 75x80 cm
in fabric 1807 col. 01
quilted version
Butter low table
Cime Colors carpet



design T.S.P.
(Resp. Nicola Pavan)
production year 2019
restyling 2024

technical data
p. 441

Ola



Poltrona 80x86 cm
in tessuto Teddy col. 01/1

Armchair 80x86 cm
in fabric Teddy col. 01/1





design Paolo Grasselli
production year 2023

technical data
p. 442

Pan Flute

Pan Flute

Poltrona 80x70 cm
in tessuto Metis col. 01
Tavolino Hexa
Tappeto Graphic Pink

Armchair 80x70 cm
in fabric Metis col. 01
Hexa low table
Graphic Pink carpet



Poltrona 105x75 cm
in tessuto Seventy col. 01
Tavolino Più

Armchair 105x75 cm
in fabric Seventy col. 01
Più low table



design Saba Italia + A. Marras
production year 2020

technical data
p. 426

Oltremare



Poltrona 105×75 cm
 in tessuto Lario col. 1406
 Divano 225×83 cm
 in tessuto Seventy col. 01
 Tavolino Hexa
 Tavolino Più
 Tavolino Leyva

Armchair 105×75 cm
 in fabric Lario col. 1406
 Sofa 225×83 cm
 in fabric Seventy col. 01
 Hexa low table
 Più low table
 Leyva low table

Beauty





Poltrona Beauty 45x49 cm
in tessuto Charme col. 900
Scrittorio Alphabet
Tappeto Cime Natural

Beauty armchair 45x49 cm
in fabric Charme col. 900
Alphabet writing desk
Cime Natural carpet



design Sergio Bicego
production year 2012

technical data
p. 418

New York armchair



Poltrona 74×83 cm
in tessuto Violet col. 08
e Tundra 01 col. 21
Tavolino Più

Armchair 74×83 cm
in fabric Violet col. 08
and Tundra 01 col. 21
Più low table



Bergère 74x91 cm
in tessuto Seventy col. 30
e pelle Club col. 7748
Pouf 58x50 cm
in pelle Club col. 7748
Consolle Hexa

Bergère 74x91 cm
in fabric Seventy col. 30
and leather Club col. 7748
Pouf 58x50 cm
in leather Club col. 7748
Hexa console

design Sergio Bicego
production year 2014

technical data
p. 418

New York bergère



Poltrona 76x80 cm
in tessuto Avant-Après col. 16
Tavolino Leyva

Armchair 76x80 cm
in fabric Avant-Après col. 16
Leyva low table

design Nicola Pavan
production year 2020

technical data
p. 444

Sunset armchair



design Nicola Pavan
production year 2020

technical data
p. 444

Sunset bergère





Bergère 76×87 cm
in pelle Ocean col. 14
Tavolino Hexa

Bergère 76×87 cm
in leather Ocean col. 14
Hexa low table

design Marco Zito
production year 2019

technical data
p. 439

Philo





Poltrone 83x70 cm
in tessuto Seventy col. 99
Tavolino Hexa

Armchairs 83x70 cm
in fabric Seventy col. 99
Hexa low table



design Emilio Nanni
production year 2016

technical data
p. 440

Kepi



Poltrona 90x78 cm
in tessuto Seventy col. 01

Armchair 90x78 cm
in fabric Seventy col. 01





Poltrona 90×78 cm
in tessuto Diplo col. 24
Tavolino Più

Armchair 90×78 cm
in fabric Diplo col. 24
Più low table

Poltrona 77x79 cm
in Intreccio Monocolore
Tavolini Più
Paravento Shade

Armchair 77x79 cm
in Monocolor Braid
Più low tables
Shade screen

design Enzo Berti
production year 2006/2018

technical data
p. 445

Sitar





Poltrona 77x79 cm
in Intreccio Monocolore
Tavolino Più
Paraventi Shade

Armchair 77x79 cm
in Monocolor Braid
Più low table
Shade screens



Poltrone 77x79 cm
e pouf 77x65 cm
in Intreccio Bicolore
Tavolini Più
Paraventi Shade

Armchairs 77x79 cm
and pouf 77x65 cm
in Bicolor Braid
Più low tables
Shade screens



design Sergio Bicego
production year 2022
restyling 2024

technical data
p. 446

Fleur





Poltrona Fleur
90x76 cm
in tessuto Chic col. 07

Fleur armchair
90x76 cm
in fabric Chic col. 07

design Giuseppe Viganò
production year 2016

technical data
p. 447

Chillout



Poltrona 84x90 cm
e pouf 61x48 cm
in tessuto
Vegas Velvet col. 14

Armchair 84x90 cm
and pouf 61x48 cm
in fabric
Vegas Velvet col. 14



design Sergio Bicego
production year 2003

technical data
p. 448

Chance



Poltrona 80×80 cm
in tessuto J'Adore col. 08
Tavolino Più

Armchair 80×80 cm
in fabric J'Adore col. 08
Più low table



design Sergio Bicego
production year 2012

technical data
p. 449

Amélie



Poltrona 73x70 cm
in tessuto
Vegas Velvet col. 20

Armchair 73x70 cm
in fabric
Vegas Velvet col. 20



design Giuseppe Viganò
production year 2010

technical data
p. 450

Bustier



Poltrona 86x84 cm
in tessuto Violet col. 31
Tavolino Hexa

Armchair 86x84 cm
in fabric Violet col. 31
Hexa low table



design Sergio Bicego
production year 2005
restyling 2012

technical data
p. 451

No Logo Light



No Logo Light

Poltrone 81x93 cm
in tessuto Teddy col. 07/24
Tavolino Più

Armchairs 81x93 cm
in fabric Teddy col. 07/24
Più low table



design Sergio Bicego
production year 2016

technical data
p. 434

Essentiel



Essentiel

Poltrone 87x95 cm
in tessuto Lario col. 58
Consolle Hexa

Armchairs 87x95 cm
in fabric Lario col. 58
Hexa console





Poufs & Benches

- 378 Beauty - pouf
- 380 Geo - pouf
- 382 Island - pouf
- 384 Cookie - pouf
- 388 Pixel - pouf
- 390 Oltremare - bench
- 394 Pan Flute - bench
- 398 New York Suite - bench

Pouf 45 cm
in tessuto Embrace col. 96

Pouf 45 cm
in fabric Embrace col. 96

design Saba Italia
production year 2024

technical data
p. 443

Beauty pouf



Pouf 60 cm in tessuto
Couture col. 260
Pouf 75 cm in tessuto
Violet col. 12
Pouf 90 cm in tessuto
J'Adore col. 08

Pouf 60 cm in fabric
Couture col. 260
Pouf 75 cm in fabric
Violet col. 12
Pouf 90 cm in fabric
J'Adore col. 08

design Paolo Grasselli
production year 2017

technical data
p. 438

Geo pouf



Pouf 65x50 cm in tessuto
suggerito Couture col. 240
Pouf 83x65 cm in tessuto
suggerito Chic col. 12
Pouf 130x105 cm in tessuto
Sweet Velvet col. 24
Consolle Hexa

Pouf 65x50 cm in fabric
suggested Couture col. 240
Pouf 83x65 cm in fabric
suggested Chic col. 12
Pouf 130x105 cm in fabric
Sweet Velvet col. 24
Hexa console

design Serena Confalonieri
production year 2018

technical data
p. 452

Island pouf



design Sergio Bicego
production year 2020

technical data
p. 453

Cookie pouf



Pouf tondo 100 cm
in tessuto Violet col. 05
Pouf tondo 130 cm
in tessuto Vegas Velvet col. 60
Pouf 75x75 cm in tessuto
Creta col. 3E

Round pouf 100 cm
in fabric Violet col. 05
Round pouf 130 cm
in fabric Vegas Velvet col. 60
Pouf 75x75 cm in fabric
Creta col. 3E



Pouf 42x42 cm
in tessuto
Avant-Après col. 18
Tavolino Più

Pouf 42x42 cm
in fabric
Avant-Après col. 18
Più low table

design Sergio Bicego
production year 2019

technical data
p. 410

Pixel pouf



design Saba Italia + A. Marras
production year 2020

technical data
p. 426

Oltremare bench



Panca 145x48 cm
in tessuto Seventy col. 01
Tavolino Più

Bench 145x48 cm
in fabric Seventy col. 01
Più low table



design Paolo Grasselli
production year 2022

technical data
p. 442

Pan Flute bench





Panca 142x46 cm
in tessuto Curly col. 21

Bench 142x46 cm
in fabric Curly col. 21



Panca 140x65 cm
in tessuto Lario col. 1403

Bench 140x65 cm
in fabric Lario col. 1403



design Sergio Bicego
production year 2015

technical data
p. 418

New York Suite bench

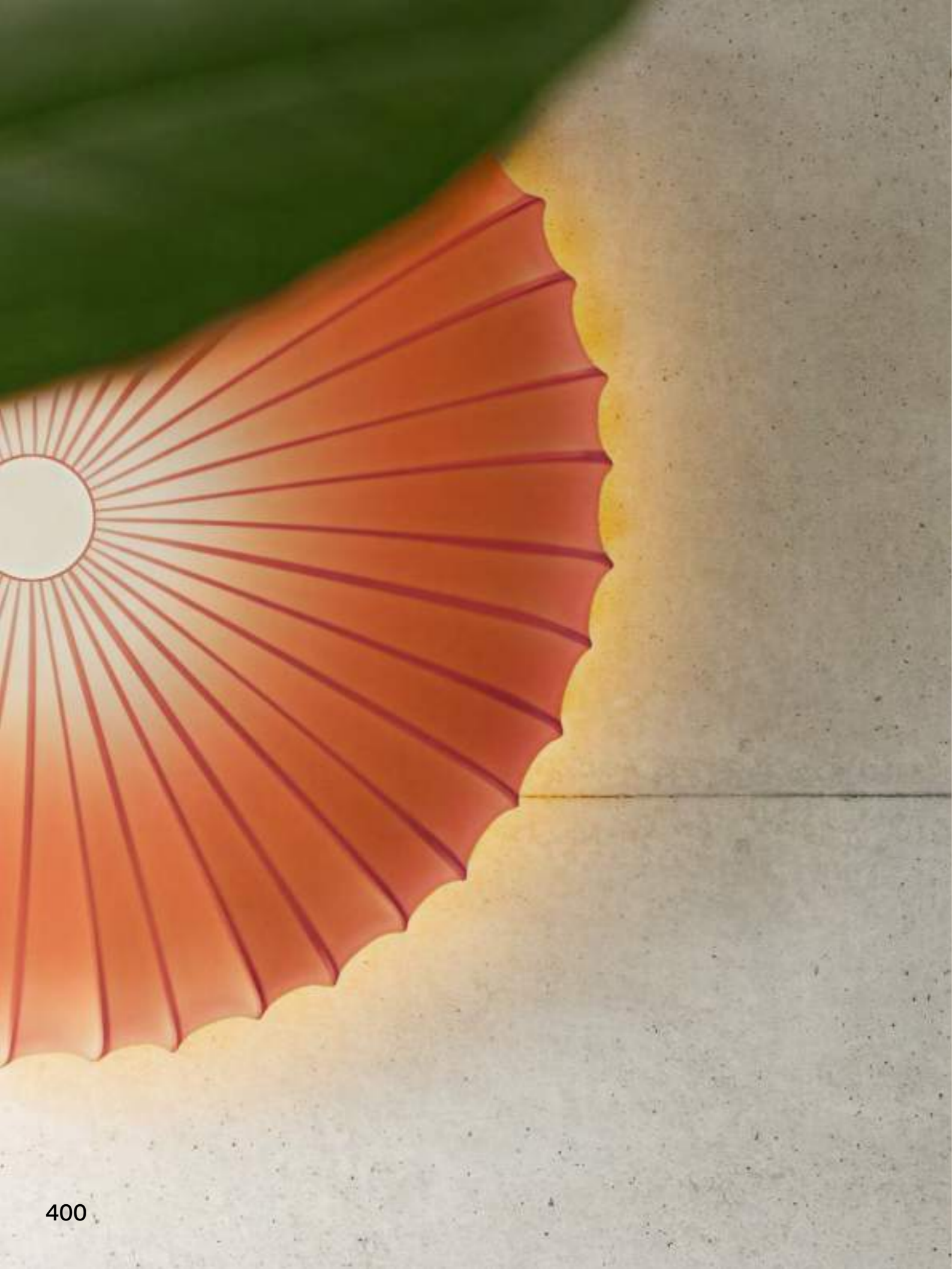

Technical data

Sofas

- 404 ● Vela Piping
- 406 ● Metis
- 408 ● Simposio
- 410 ● Pixel
- 414 ● Ananta
- 416 ● Limes
- 418 New York Suite
- 404 Vela
- 420 ● My Taos
- 422 ● Avant-Après
- 424 ● Pixel Light
- 426 Oltremare
- 428 Gala
- 430 ● Rendez-vous
- 427 Karma
- 432 Up
- 434 Essentiel
- 436 Livingston

Small Sofas

- 438 Geo
- 439 Philo
- 440 Kepi
- 418 New York - dining

Armchairs

- 438 Geo
- 438 Baby Geo
- 441 Ola
- 442 Pan Flute
- 426 Oltremare
- 443 Beauty
- 418 New York - armchair
- 418 New York - bergère
- 444 Sunset - armchair
- 444 Sunset - bergère
- 439 Philo
- 440 Kepi
- 445 Sitar
- 446 Fleur
- 447 Chillout
- 448 Chance
- 449 Amélie
- 450 Bustier
- 451 No Logo Light
- 434 Essentiel

Poufs & Benches

- 443 Beauty - pouf
- 438 Geo - pouf
- 452 Island - pouf
- 453 Cookie - pouf
- 410 Pixel - pouf
- 426 Oltremare - bench
- 442 Pan Flute - bench
- 418 New York Suite - bench

● *Modular System Sofas*

— All products are available for Contract Solutions

it — Le vele sono da sempre uno dei simboli di compromesso tra l'uomo e la natura, e nei volumi del divano Vela, sono le preziose trapuntature, ispirate da randa e fiocco nautici, a ricordacene l'andamento quando queste ne raccolgono il vento. Il comfort del divano lineare Vela trova una nuova espressione componibile attraverso il divano modulare Vela Piping, in cui il rimando al mondo nautico è questa volta rappresentato dal cordolo "piping", che, come una cima nautica, incornicia la silhouette di ogni volume. Completamente sfoderabile.

en — Sails have always symbolized the balance between man and nature, and in the Vela sofa's volumes, the elegant quilting, inspired by the shapes of nautical mainsails and jibs, reminds us of their movement as they catch the wind. The comfort of the linear Vela sofa finds new modular expression in the Vela Piping version, where the nautical reference is represented by the piping detail, like a sailing rope outlining each volume's silhouette. Fully removable covers.



p. 142 Vela - sofa

p. 008 Vela Piping - sofa system

Vela / Divani / Sofas

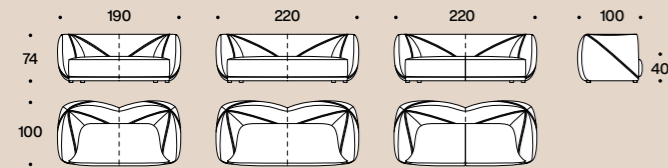

Esempi compositivi / Composition examples

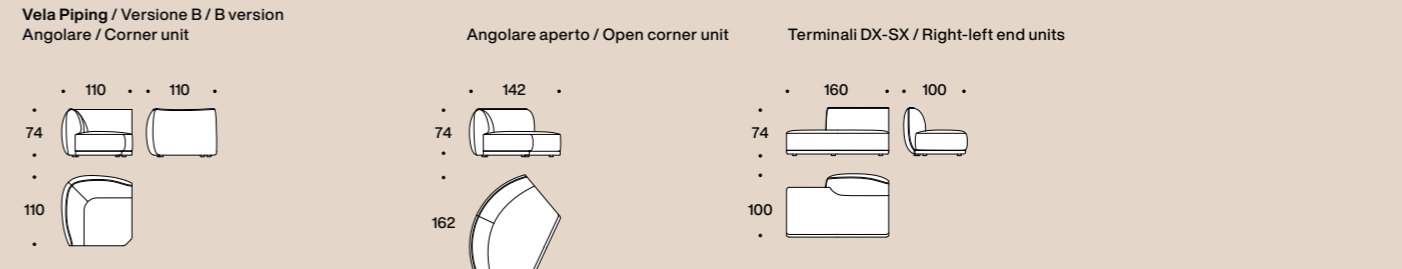
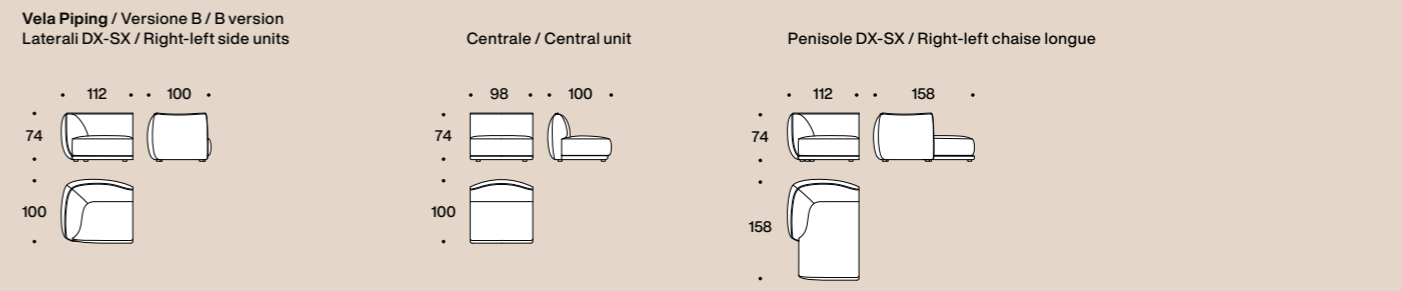
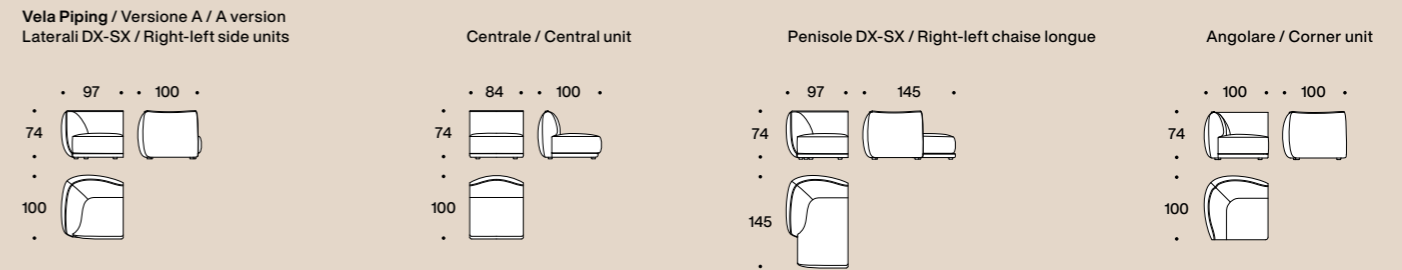
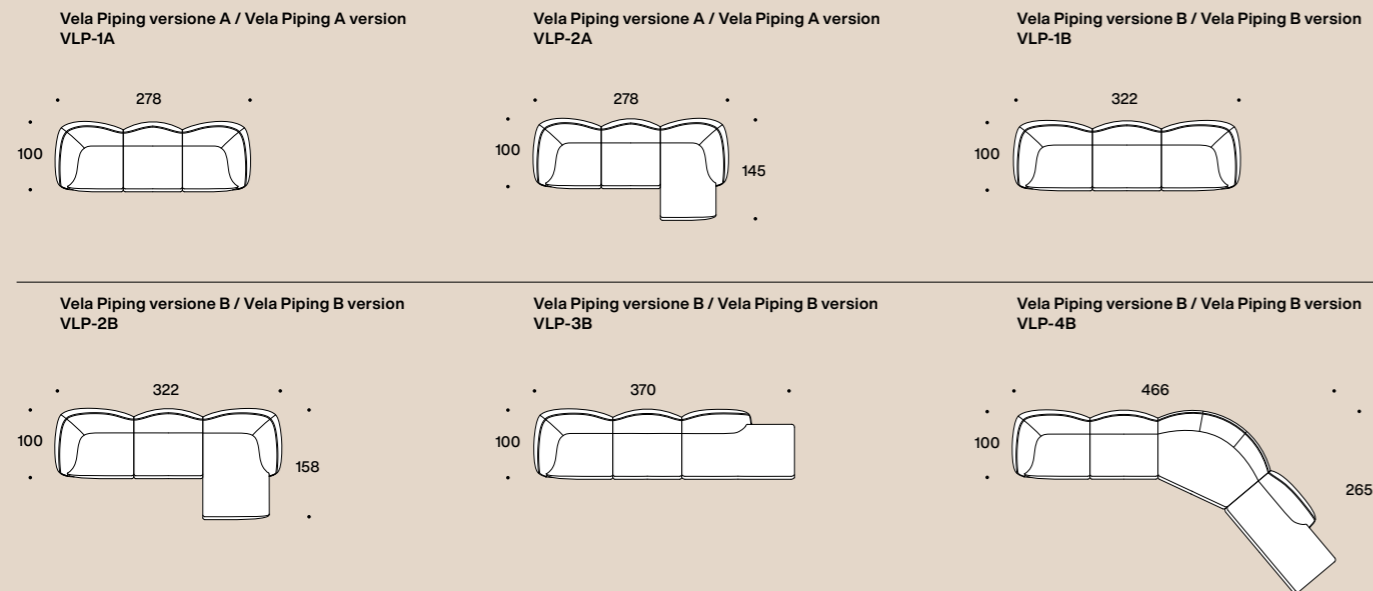

it — Metis arricchisce la sezione Saba che interpreta il divano come elemento mutevole e organico. Il suo nome ha origini lontane: i Greci indicavano con Mètis l'intelligenza pratica, quella che consente di risolvere abilmente, e per vie non convenzionali, i problemi di tutti i giorni, adattandosi alle diverse circostanze, con elasticità ed ingegno. L'intuizione pratica che sta alla base di Metis è l'utilizzo di un'elegante cerniera metallica a vista, quale elemento di snodo tra gli schienali, applicazione che rende possibile la massima flessibilità senza gesti faticosi. Lineare e soffice al tempo stesso, Metis è caratterizzato da preziose trapuntature che scolpiscono i volumi di seduta, schienali e braccioli. Attraverso la moltiplicazione e rotazione degli elementi base, a uno e due posti, di cui è composto, il sistema di sedute consente molteplici configurazioni ed espressioni estetiche home e contract. Completamente sfoderabile.

en — Metis enriches the Saba product category that interprets the sofa as a changing and organic element. Its name has distant origins: the Greeks indicated with the word Mètis a practical intelligence, one that allows for everyday problems to be solved skillfully, and in unconventional ways, adapting to different circumstances, with elasticity and ingenuity. The practical intuition behind the Metis sofa is the use of an elegant and visible metal hinge as a joint element between the backrests. This application allows for maximum flexibility without strenuous gestures. Linear yet soft at the same time, Metis is characterized by precious quilting that sculpts the volumes of the seats, backrests and armrests. Through the multiplication and rotation of the basic one or two seat elements, of which it is composed, the seating system allows multiple configurations and aesthetic expressions for the home and contract environment. Fully removable covers.



p. 026 Metis - sofa system

Esempi compositivi / Composition examples

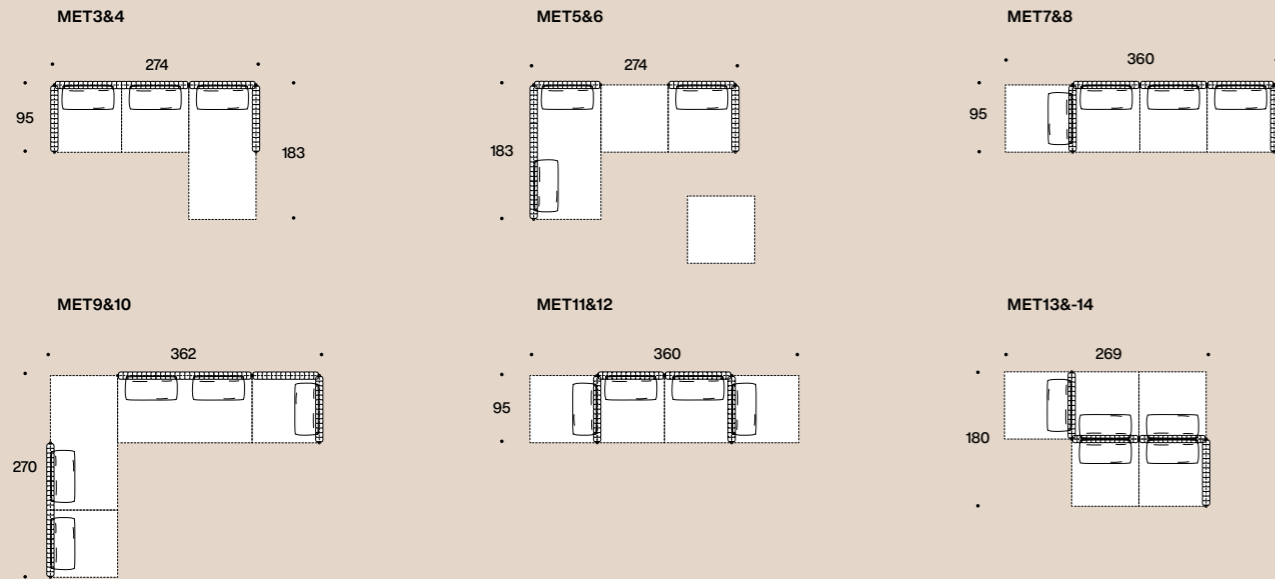

Basi / Bases

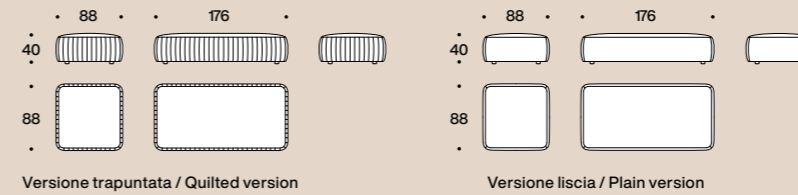

Versione trapuntata / Quilted version

Versione liscia / Plain version

Schienali centrali / Central backrests

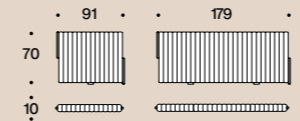

Schienali singoli / Single backrests

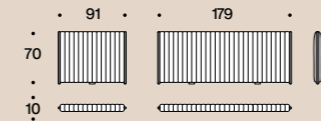

Fianco divano con base e schienale / Side sofa with base e backrest

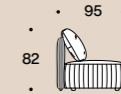

Schienali terminali / End unit backrests

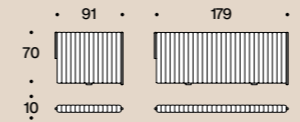

Versione DX / Right version

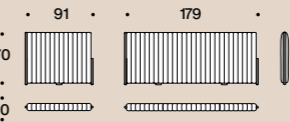

Versione SX / Left version

Cuscino schiena / Back cushion

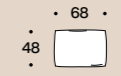

Finitura snodo schienale / Backrest joint finish



- 1 Nero opaco / Matt black
- 2 Black nichel / Black nickel

it — L'ispirazione di Simposio, il sistema di sedute firmato Studiopepe, trae origine da un dialogo tra concetti da intrecciare insieme in una sintesi armonica: forme semplici e pure scolpite in linee sinuose, ma tali da essere percepite senza tempo. Il divano Simposio con i suoi elementi tondi e lineari, diventa luogo ideale di accoglienza dove conversare sul mistero della bellezza, creando piccole o grandi arene domestiche. Anche il piede perde la sua formale funzione e diventa elemento distintivo atto ad evocare la sensualità della pressione sulla stoffa. Una tappezzeria coraggiosa ha eliminato la maggior parte delle cuciture e solo una piega laterale definisce il profilo degli elementi, come un peplo di reminiscenza greca. Completamente sfoderabile.

en — The inspiration for Simposio, the seating system designed by Studiopepe, originates from a dialogue between concepts to be intertwined together in a harmonious synthesis: simple and pure shapes sculpted in sinuous lines, yet to be perceived as timeless. The Simposio sofa, with its rounded and linear elements, becomes an ideal place of hospitality where one can converse about the mystery of beauty, creating small or large domestic arenas. Even the foot structure loses its formal function and becomes a distinctive element, designed to evoke the sensuality of a pressure point on fabric. A bold upholstery has eliminated most of the seams, only a side fold defines the profile of the elements, reminiscing a Greek peplos. Fully removable covers.



p. 046 Simposio - sofa system

Esempi compositivi / Composition examples

SMP01

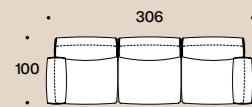

SMP02

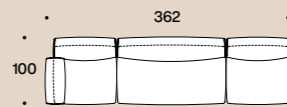

SMP03

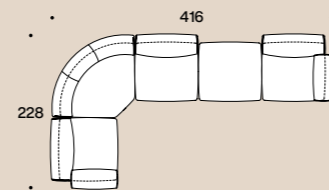

SMP04

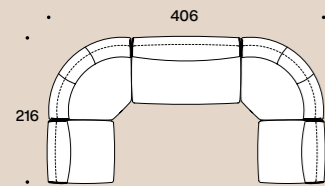

Extra comp. 01

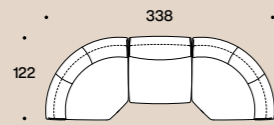

Extra comp. 02

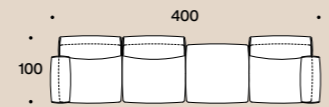

Centrali / Central units

Questi articoli sono spendibili distintamente come poltrona e divanetto / These items are usable as armchair and small sofa

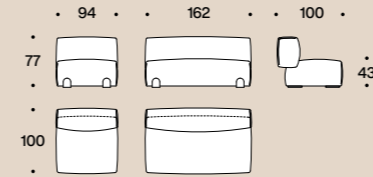

Pouf componibile / Modular pouf

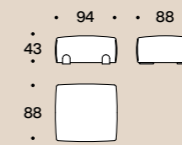

Laterali DX-SX / Right-left side units

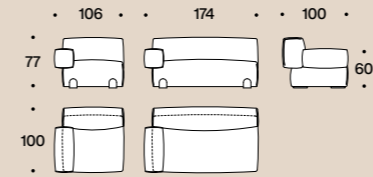

Angolare / Corner unit

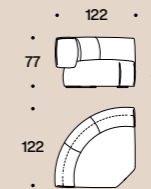

Finitura piedi - laccatura opaca / Feet finish - matt lacquering



- 1 Nero / Black
- 2 Verniciato corten / Painted corten
- 3 Sabbia / Sand

it — Il divano Pixel è caratterizzato da una serie di elementi che si combinano liberamente tra loro, sfruttando un esclusivo innesto. È così possibile scomporre i braccioli e gli schienali dalle basi, per creare nuove composizioni in assoluta libertà. Le sedute in piuma sono caratterizzate dalla particolare cucitura trapuntata, che evidenzia le infinite possibilità di combinare i tessuti della collezione Saba, per creare ogni volta un divano unico e personalissimo. Grazie alla particolare forma degli schienali e dei braccioli, le dimensioni complessive del divano risultano sempre molto contenute, sia in larghezza che in profondità, senza penalizzarne l'estetica. Il divano Pixel è stato accuratamente concepito in base ai criteri di ergonomia, per avere il massimo comfort su un prodotto altamente ricercato dal punto di vista stilistico. Pouf coordinato. Completamente sfoderabile.

en — The Pixel sofa is characterized by a series of elements which can be combined freely, using an exclusive connector. The arm and back rests can be detached from the base to create endless new arrangements. The feather-padded seats are characterized by the particular quilted stitching, which highlights the infinite possibilities of combining the fabrics of the Saba collection, to create a unique and very personal sofa every time. Thanks to the particular shape of the back and arm rests, the overall size of the sofa is small, both in terms of width and depth, without compromising its aesthetics. The Pixel sofa has been carefully and ergonomically designed to provide the greatest comfort and a highly stylish product. Coordinated pouf. Fully removable covers.



p. 070 Pixel - sofa system



p. 388 Pixel - pouf

Esempi compositivi / Composition examples

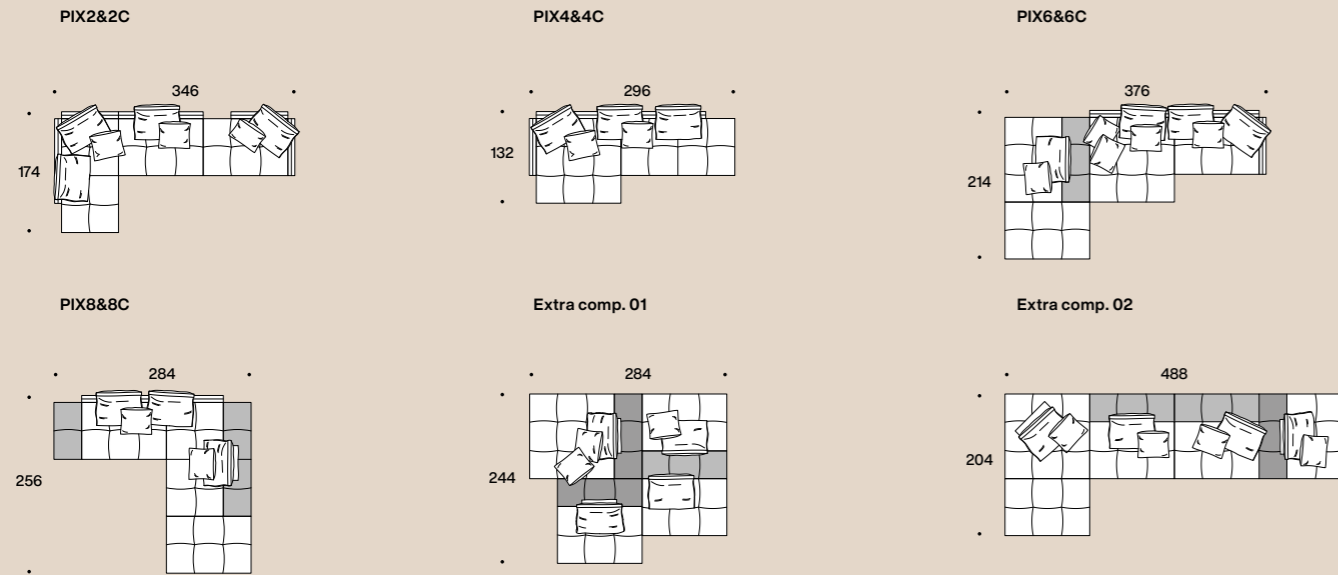

Schienali / Backrests

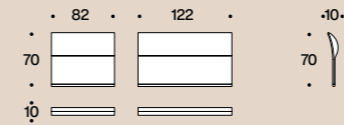

Pouf

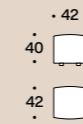

Basi / Bases

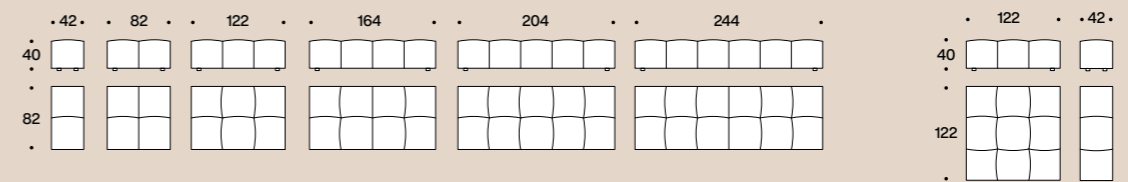

Schienali - Braccioli / Backrests - Armrests



Divani fissi / Fixed sofas

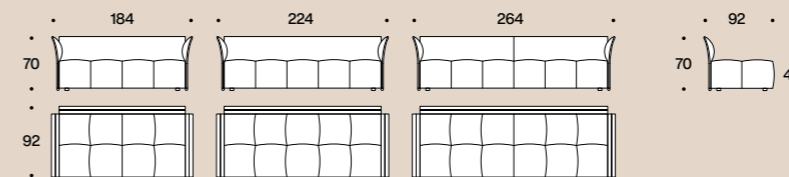

Laterali fissi DX-SX / Fixed right-left side units

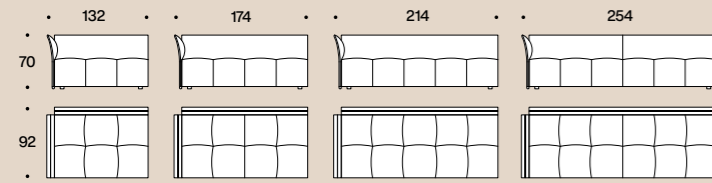

Centrali fissi / Fixed central units

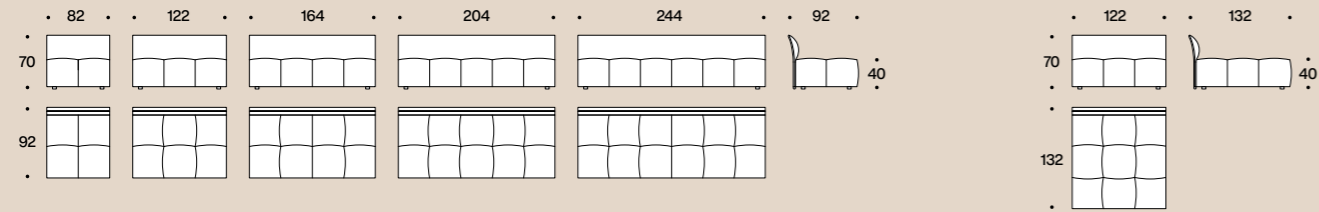

Penisole fisse DX-SX / Fixed right-left chaise longue

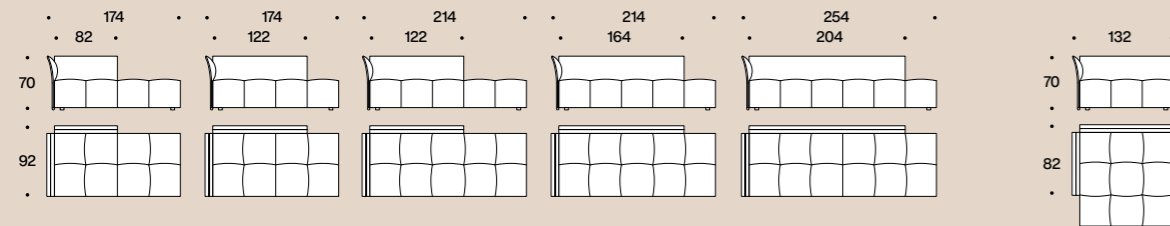

Angolari fissi / Fixed corner units



Cuscini schiena / Back cushions



Rullo / Roll

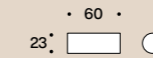

Cuscini arredo / Throw cushions

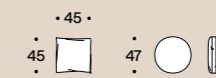

Finitura piedi schienale sottile / Slim backrest feet finish

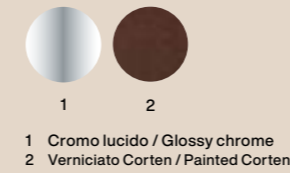

it — A un ventennio dalla sua progettazione, Ananta continua a sorprendere per la sua modernità. Nato con il preciso scopo di muoversi nello spazio in modo facile, consentendo diverse configurazioni, torna ora svelando una nuova possibilità compositiva, ovvero la combinazione bifacciale degli elementi. Ananta ha anticipato il moderno concetto di fluidità ed è per questo suo valore intelligente che ce ne prendiamo cura per renderlo nel tempo sempre più coerente al moderno abitare. Il restyling oltre a rendere possibile l'aggancio delle sedute in ogni direzione, lo ha addolcito ammorbidendo tutte le imbottiture, nuovi elementi pouf sono stati aggiunti alla già ricca modulistica e infine una nuova essenza dal colore morbido va a integrare la scelta per gli accessori tavolini. Memoria, innovazione ed eleganza fanno di Ananta un prodotto per sempre. Completamente sfoderabile.

en — Twenty years since its original design, Ananta continues to surprise with its modernity. Created with the precise purpose of easily moving through space by allowing different configurations, it now unveils a new compositional possibility, the double-sided combination of elements. Ananta anticipated the modern concept of fluidity and for this intelligent value it withholds, we care for it to be more and more consistent with the concept of modern living over time. The restyling, in addition to making it possible to hook the seats in every direction, has mellowed it by softening all the padding. New pouf elements have been added to the already rich module options and lastly, a new soft wood finish has been integrated for the coffee table accessories. Memory, innovation and elegance make Ananta an everlasting product. Fully removable covers.



p. 090 Ananta - sofa system

Esempi compositivi / Composition examples

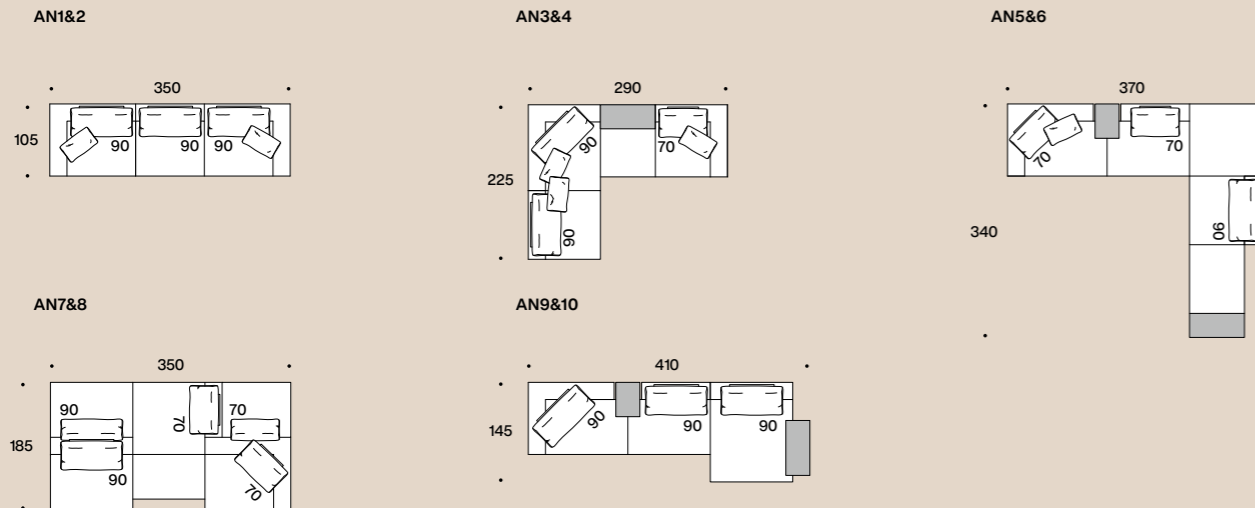

Basi / Bases

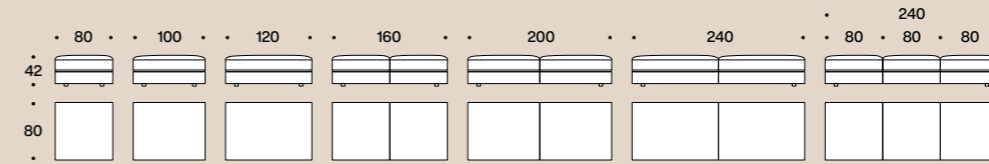

Basi / Bases

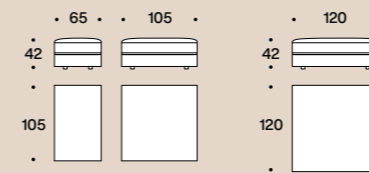

Schienali angolari / Corner backrests

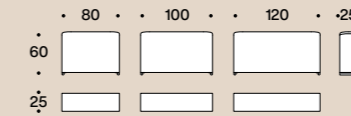

Schienali / Backrest

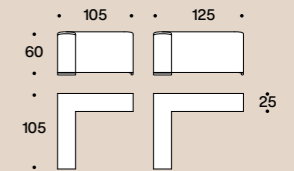

Bracciolo / Armrest

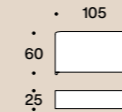

Fianco - Base con schienale / Side - Base with backrest



Cuscini schiena con rullo / Back cushions with roll

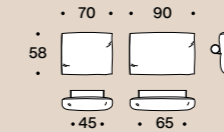

Cuscini schiena / Back cushions



Solo per uso in composizioni bifacciali (compresenza cuscino schiena con rullo) / Only for use in double-face compositions (co-presence back cushion with roll)

Cuscino arredo / Throw cushion



Tavolini / Low tables

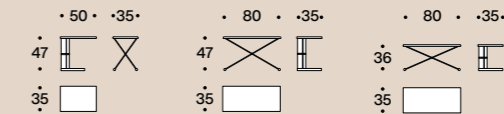

Finitura piedi schienale e struttura tavolino / Backrest feet and low table frame finish



- 1 Black nichel / Black nickel
- 2 Verniciato Corten / Painted Corten

Top tavolini - finitura cuoio / Low tables top - leather finish



- 1 Honey
- 2 Testa di moro / Dark brown

Top tavolini - finitura essenza / Low tables top - wood finish



- 1 Rovere chiaro / Light durmast
- 2 Noce Canaletto / Walnut veneer

it — Limes è un sistema di sedute che ha anticipato il valore della flessibilità. La nuova versione preserva la funzionalità degli schienali amovibili, ma valorizza le proporzioni delle sedute e si propone con nuove finiture e dettagli sartoriali. Le strutture dei pannelli schiena e il piede diventano una presenza precisa e il nuovo intreccio esalta il retro divano. La doppia altezza dei cuscini schiena e la finitura liscia o intrecciata dei pannelli fanno del divano Limes un progetto altamente personalizzabile. Completamente sfoderabile.

en — Limes is a seating system that anticipated the value of flexibility. The new version preserves the functionality of the removable backrests, but enhances the proportions of the seats and it offers new finishes and sartorial details. The structures of the back panels, as well as the foot, become a precise presence and the new weave enhances the rear of the sofa. The double height of the back cushions and the panels' smooth or woven finish make the Limes sofa a highly customisable project. Fully removable covers.



p. 110 Limes - sofa system

Esempi compositivi / Composition examples

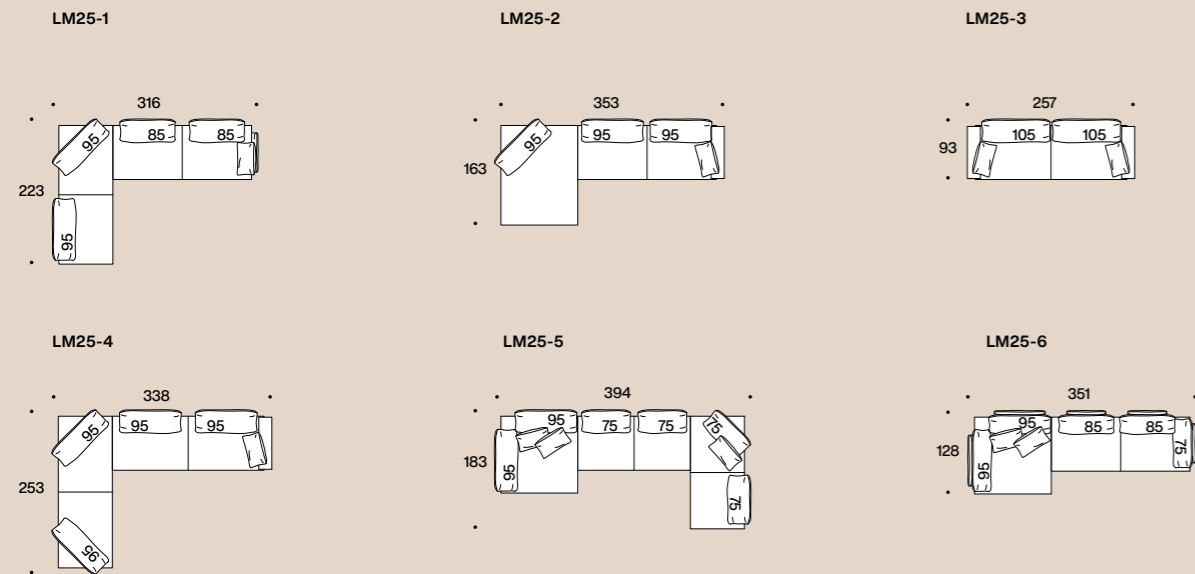

Basi con piedi in metallo / Bases with metal feet

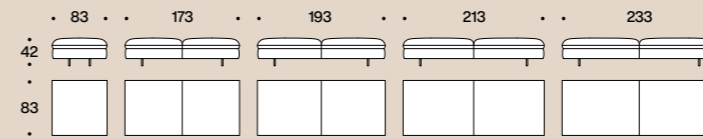

Penisole con piedi in metallo / Chaise longue with metal feet

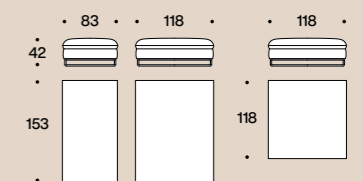

Fianco con schienale e cuscino schiena alto / Side backrest with high back cushion

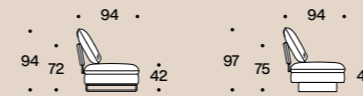

Basi con piedi in metallo / Bases with metal feet

Basi con piedi in metacrilato / Bases with methacrylate feet

Fianco con schienale e cuscino schiena basso / Side backrest with low back cushion



Basi con piedi in metallo / Bases with metal feet

Basi con piedi in metacrilato / Bases with methacrylate feet

Bracciolo tessuto e intreccio imbottito / Fabric and Padded braided armrest

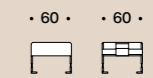

Cuscini schiena alti / High back cushions

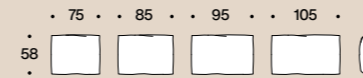

Cuscini schiena bassi / Low back cushions

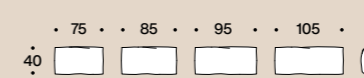

Schienali tessuto e intreccio imbottito / Fabric backrests and Padded braided backrests

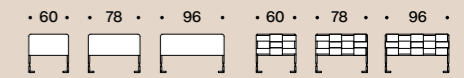

Cuscino bracciolo / Armrest cushion

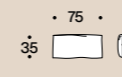

Bracciolo rullo / Roll armrest

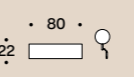

Cuscino bracciolo - arredo / Armrest - throw cushion

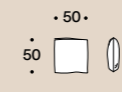

Tavolini / Low tables

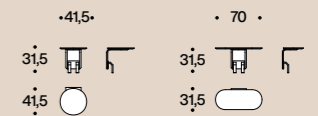

Finitura laccata opaca - piedi e struttura pannelli schiena / Matt lacquered finish - feet and back structure panels



- 1 Nero / Black
- 2 Verniciato Corten / Painted Corten
- 3 Sabbia / Sand

Finitura piedi / Feet finish



- 1 Metacrilato / Methacrylate

Finitura tavolini / Low tables finish



- 1 Rovere chiaro / Light durmast
- 2 Rovere tinto nero / Black painted durmast
- 3 Rovere tinto noce / Walnut painted durmast

it — Il tratto distintivo della collezione New York, è l'intramontabile classicità del disegno ripensato in una forma contemporanea. La trapuntatura del rivestimento, conferisce al divano un accento sofisticato in perfetto equilibrio con le forme minimaliste della struttura metallica. Avvolgente e ospitale si declina in svariate dimensioni, sia nelle forme fisse che componibili. La collezione New York illustrata nel Volume 1 comprende l'iconica poltrona e bergère, entrambe double-face, il divanetto dining perfetto per arredare piccoli spazi come l'ingresso e si arricchisce di altri complementi quali sedute e prodotti outdoor nel Volume 2. Completamente sfoderabile.

en — The distinctive trait of the New York collection is the timeless classicism of the design, reimagined in a contemporary form. The quilted upholstery gives the sofa a sophisticated accent, in perfect balance with the minimalist lines of the metal frame. Welcoming and hospitable, it is available in various sizes, in both fixed and modular configurations. The New York collection shown in Volume 1 includes the iconic armchair and bergère, both double-faced, as well as the small dining loveseat, ideal for furnishing small spaces such as entryways. It is further enriched with other pieces like seating and outdoor products in Volume 2. Fully removable covers.



p. 126 New York Suite - sofa



p. 398 New York Suite - bench



p. 290 New York dining - small sofa



p. 320 New York - armchair



p. 324 New York - bergère

Finitura struttura divano, panca / Sofa, bench frame finish

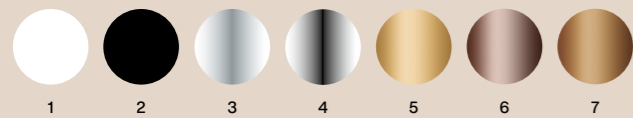

- 1 Bianco / White
- 2 Nero / Black
- 3 Cromo lucido / Glossy chrome
- 4 Black nichel / Black nickel
- 5 Ottone satinato / Satin brass
- 6 Bronze Copper Matt
- 7 Bronze Gold Matt

Finitura struttura divanetto / Small sofa frame finish



- 1 Bianco / White
- 2 Nero / Black
- 3 Cromo lucido / Glossy chrome
- 4 Black nichel / Black nickel

Finitura struttura poltrona, bergère / Armchair, bergère frame finish



- 1 Bianco / White
- 2 Nero / Black
- 3 Rosso / Red
- 4 Azzurro / Azure
- 5 Cromo lucido / Glossy chrome
- 6 Black nichel / Black nickel
- 7 Ottone satinato / Satin brass
- 8 Bronze Copper Matt
- 9 Bronze Gold Matt

Divani / Sofas

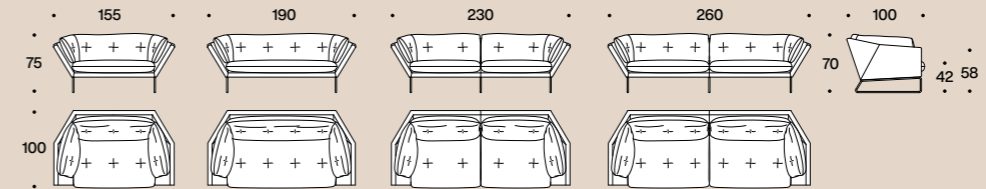

Laterali DX-SX / Right-left side units

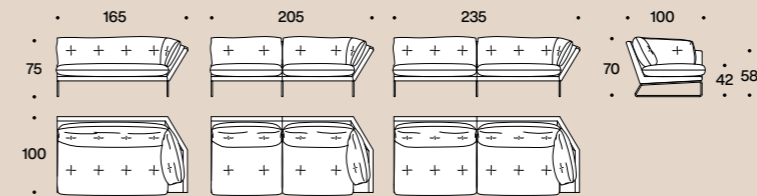

Cuscini arredo / Throw cushions



Penisole DX-SX / Right-left chaise longue

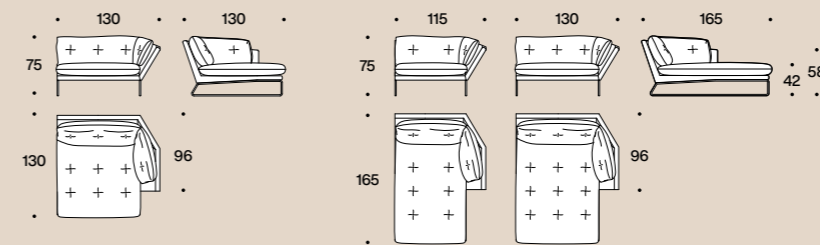

Poltrona lounge / Lounge armchair

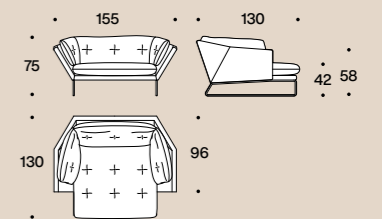

Poufs e Panche / Poufs and Benches

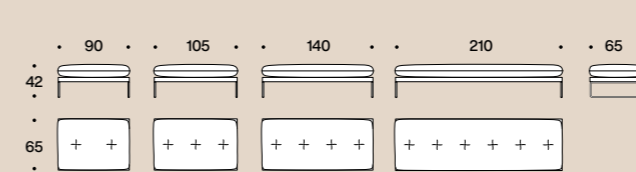

Divanetto con e senza braccioli / Small sofa with and without armrests

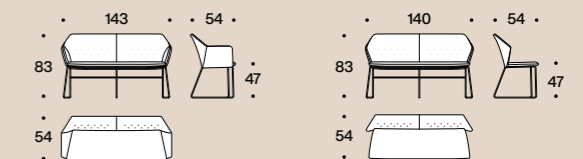

Poltrona / Armchair

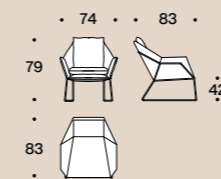

Bergère

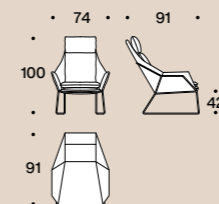

Pouf

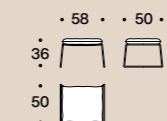

it — My Taos è il progetto di divano che meglio spiega l'identità Saba. Il lavoro di restyling si è basato sui quattro principi cardine dell'azienda: la memoria, il comfort, il design e la poesia. La memoria la si ritrova nel nuovo My Taos nella fedeltà al progetto originale mantenendo lo scorrimento in avanti e indietro delle sedute. Il comfort ha riparametrato altezze e migliorato l'ergonomia con l'uso di materiali di ultima generazione. Il design ha ridisegnato nuovi tavolini funzionali e nuovi cuscini cilindrici d'appoggio. La poesia ha arrotondato le forme, smussato spigoli, addolcito le linee. Completamente sfoderabile.

en — My Taos is the sofa that best communicates Saba's identity. Its recent redesign is based on the four pillars of the company: memory, comfort, design and poetry. Memory is found in the new My Taos as it stays true to its original design by maintaining the forward and backward movement of the pouf structures. Improved comfort has redefined heights and improved the ergonomics using the latest generation of materials. The design has integrated new functional tables and cylindrical support cushions. The element of poetry has rounded the overall form, softening all edges and lines. Fully removable covers.



p. 158 My Taos - sofa system

Esempi compositivi / Composition examples

MYT1&2

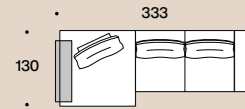

MYT3&4

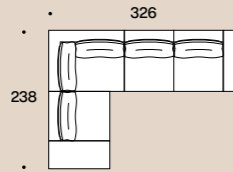

MYT5&6

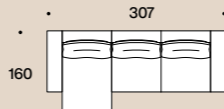

MYT7&8

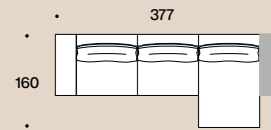

MYT9&10

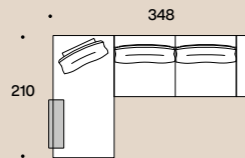

MYT11&12

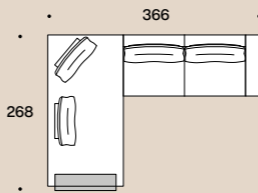

MYT13&14

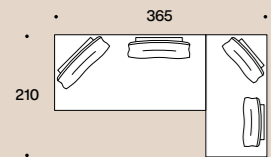

MYT15&16

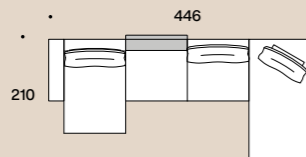

Basi / Bases

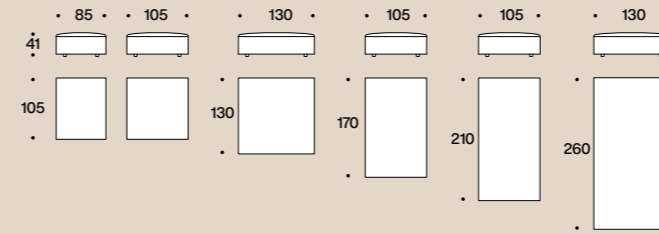

Pouf Terminale DX-SX / Right-left end unit pouf

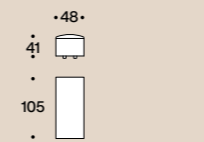

Braccioli DX-SX / Right-left armrests



Tavolino bracciolo DX-SX / Right-left low table armrest

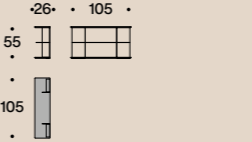

Centrali / Central units

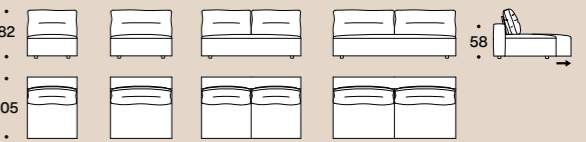

Penisole / Chaise longue

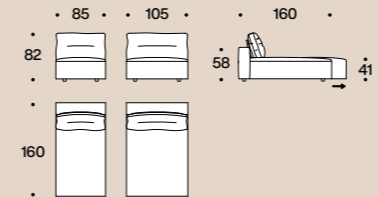

Angolare DX-SX / Right-left corner unit

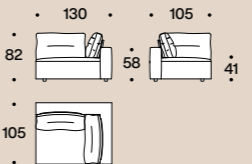

Tavolini / Low tables

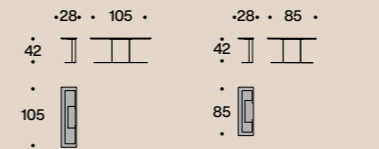

Cuscini schiena / Back cushions

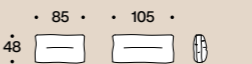

Cuscini rullo / Roll cushions

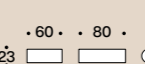

Tavolini / Low tables
Finitura struttura / Frame finish



Finitura piano / Top finish



it — Fluire, adattarsi, creare vuoti, riorganizzare spazi, accogliere e rinnovarsi. Questo è ciò che può fare il sistema di sedute Avant-Après. Rigoroso eppure leggero, il divano assume configurazioni estremamente interessanti grazie al particolare e unico sistema bracciolo/schienale che si stacca con un gesto semplice e si può posizionare lungo tutto il perimetro della base. Una danza al ritmo di un prima e dopo che può essere messa in scena ogni giorno, animata dalla voglia di sperimentare. Avant-Après ha un'allure sobria e un tratto elegante, le sedute sono appoggiate su una base di metallo rivestito in tessuto o in pelle, sollevato da terra su piedi in metallo. Raffinati accessori completano il sistema: i tavolini d'appoggio in due diverse dimensioni sono realizzati in legno noce canaletto. Completamente sfoderabile.

en — Flow, adapt, create void, rearrange space, receive and renew indefinitely. The Avant-Après seating system is able to do it all. Rigid yet lightweight, the sofa comes in fascinating configurations thanks to the special and unique armrest/backrest system that detaches with a simple movement and may be positioned all along the base. A pre-and-post dance that can be staged every day, created by the desire to try something new. Avant-Après has a sober allure and an elegant appearance. The seating is placed on a metal base upholstered in fabric or leather, resting on metal feet. Refined accessories complete the system: the side tables are walnut wood and come in two different sizes. Fully removable covers.



p. 174 Avant-Après - sofa system

Esempi compositivi / Composition examples

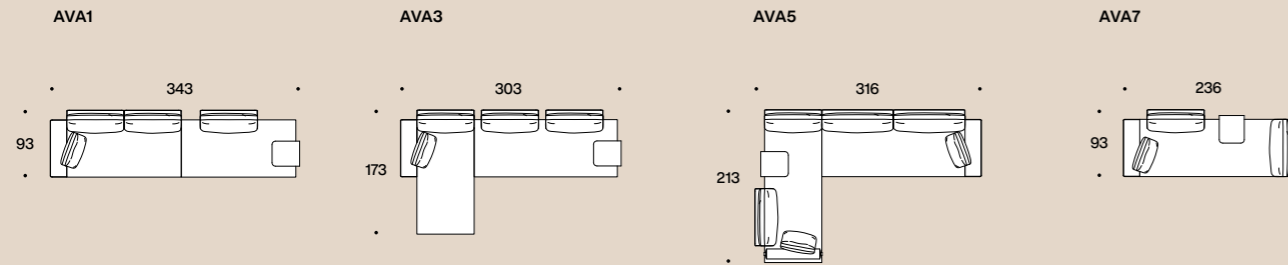

Basi / Bases

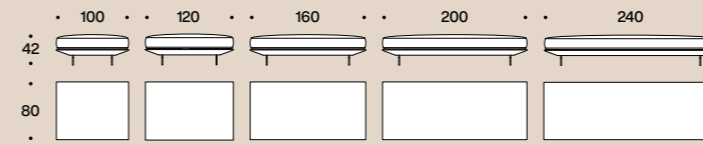

Fianco con schienale / Side backrest

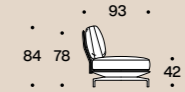

Fianco con schienale e poggiatesta / Side with head and backrest



Basi con bracciolo imbottito / Bases with padded armrest

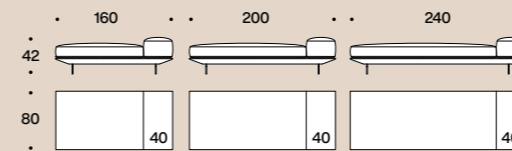

Poggiatesta / Headrest

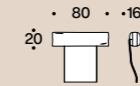

Fianco con schienale / Side backrest

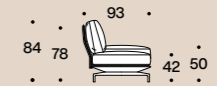

Schienali / Backrests

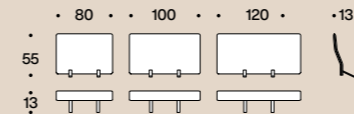

Cuscini schiena / Backrest cushions

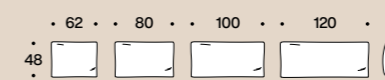

Tavolini / Low tables

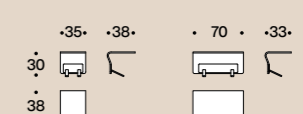

Bracciolo / Armrest

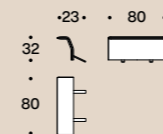

Cuscini bracciolo / Arm cushions



Cuscini arredo / Throw cushions

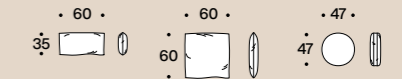

Finitura piedi / Feet finish

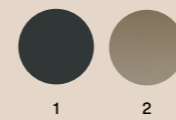

- 1 Grigio / Grey
- 2 Verniciato cromo satinato / Painted glazed chrome

Tavolini / Low tables
Finitura essenza / Essence finish



- 1 Rovere chiaro / Light durmast
- 2 Noce Canaletto / Walnut veneer

it — Il sistema di sedute Pixel-Light, nasce dal desiderio di espandere il concetto di forma flessibile per abbracciare la visione di fluidità degli spazi. Nel progettarlo, abbiamo cercato nuove possibilità di utilizzo del divano Pixel, progetto icona di Saba, alleggerendo le forme, migliorando le performances tecniche, ma mantenendo il suo stile inconfondibile, per portarlo a vivere sia negli ambienti esterni che negli spazi interni. Pixel-Light indoor conferisce leggerezza e raffinatezza agli ambienti, pur restando fedele al suo DNA nomade e fluido. Si differenzia dal progetto originale per il telaio aereo in metallo verniciato, per i nuovi e confortevoli cuscini schiena in due misure e non da ultimo per la particolare e performante tela di imbottitura in microfibra silliconata traspirante trapuntata con tela di cotone. Completamente sfoderabile.

en — The Pixel-Light seating system stems from the desire to expand on the concept of form flexibility to reach a more sophisticated one of fluidity of spaces. While designing it, we investigated new possibilities and uses for the Pixel sofa, Saba's most iconic project. We lightened its form by improving the technical performances, while still maintaining intact its unique style that now allows it to inhabit both interior and exterior spaces. Pixel-Light indoor adds lightness and elegance to any space, even though it remains faithful to its nomadic and fluid DNA. It distinguishes itself from the original project for the varnished iron aerial base, for the new comfortable back pillows in two sizes and also for the particular and high-performance padding canvas in breathable microfiber quilted with cotton canvas. Fully removable covers.



p. 190 Pixel-Light - sofa system

Esempi compositivi / Composition examples

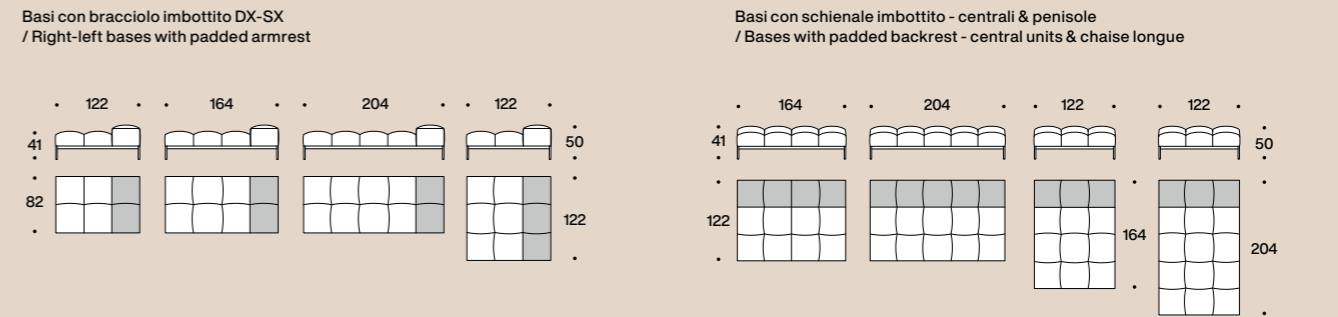
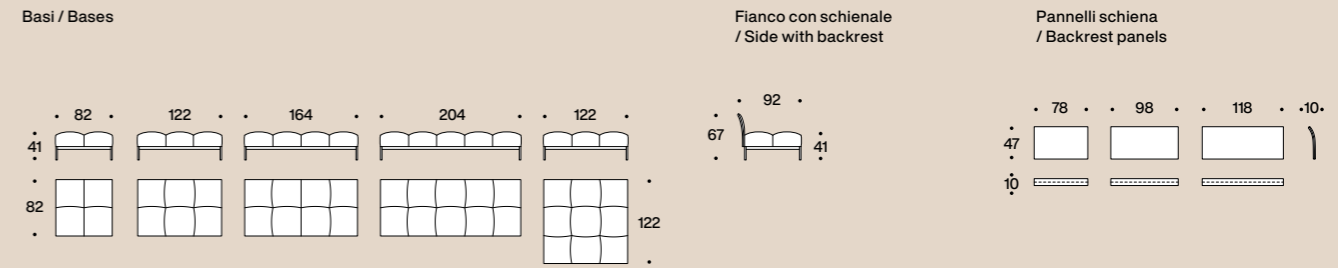
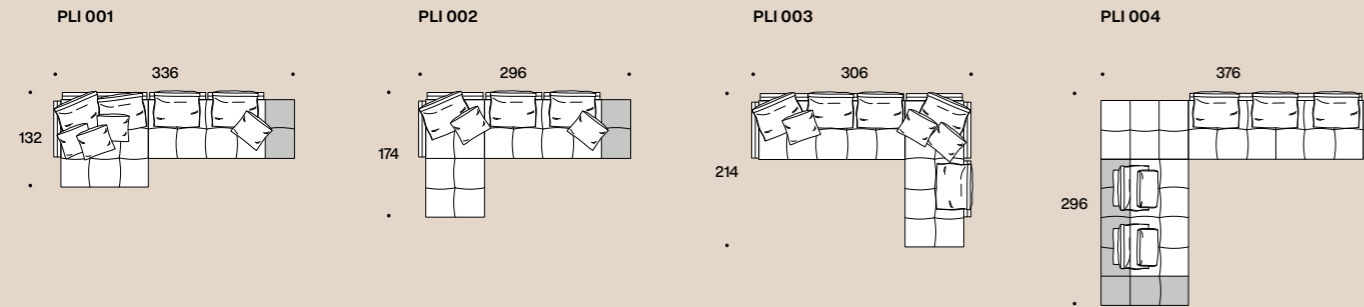

Basi DX-SX con schienale e bracciolo imbottito - laterali & angolari / Right-left bases with padded back and armrest - side & corner units

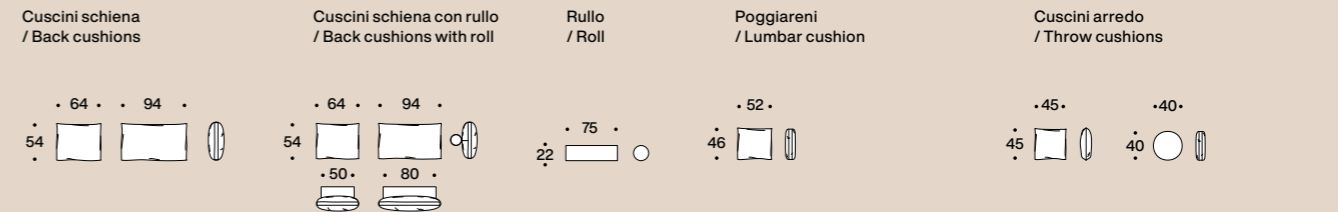
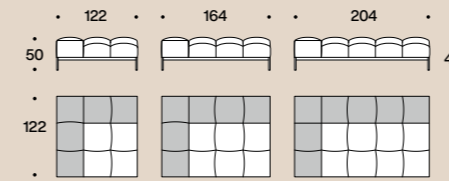

Finitura struttura / Frame finish

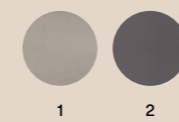

1 Champagne
2 Noir

it — La collezione di sedute “Oltremare” ideata da Antonio Marras e realizzata in collaborazione con Saba, arriva da un luogo e da un passato lontano, ricco di storia, memoria, ricordi carico di suggestioni e visioni. Le curve asimmetriche che lo racchiudono sono l’ispirazione alla base della poltroncina Oltremare che completa, assieme alla panchetta imbottita, la collezione. Un nido confortevole sospeso su una base slanciata di metallo verniciato, le cui linee essenziali rendono per contrasto la silhouette ancora più interessante. Oltremare è un sistema di sedute che, pur ammiccando al passato, comunica una forte anima contemporanea e si presta per natura a diverse interpretazioni e cambi d’abito. Completamente sfoderabile.

en — The seating collection “Oltremare” designed by Antonio Marras and produced in collaboration with Saba, stems from a far-away past and place, full of history, recollection, memories overflowing with suggestions and visions. The curve is a line that can be tamed: it forms a wave, a fold, it creates a place but it also offers an escape route. A comfortable nest suspended on a slim varnished metal base, whose essential lines render, by contrast, the armchair’s silhouette even more interesting. Oltremare is a seating system that, even though winks at the past, it communicates a strong contemporary soul and is suitable by nature to various interpretations. Fully removable covers.



p. 200 Oltremare - sofa

p. 312 Oltremare - armchair

p. 390 Oltremare - bench

Divano / Sofa

Poltrona / Armchair

Panca / Bench

Cuscino arredo / Throw cushion

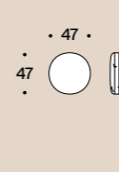
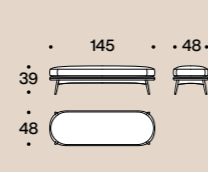
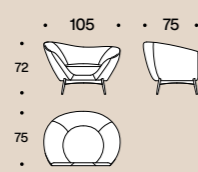
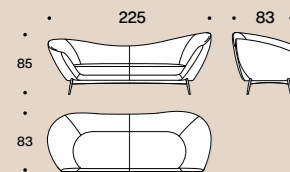

Finitura struttura / Frame finish



1 Nero / Black

it — Karma è un divano dallo stile elegante e senza tempo. Le sue proporzioni generose ma pulite, lo rendono adattabile sia ad ambienti contemporanei che di gusto classico. Equilibrato sia nella versione singola che componibile, offre un’ampia scelta progettuale. Completamente sfoderabile.

en — Karma is an elegant and timeless sofa. Its generous but clean proportions make it adaptable to both contemporary and classic environments. Balanced both in the fixed and the modular version, it offers a wide range of personalization. Fully removable covers.



p. 242 Karma - sofa

Divani / Sofas

Penisola DX-SX / Right-left chaise longue

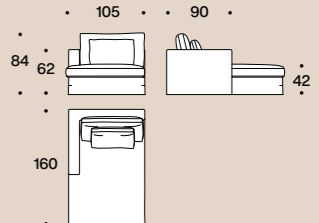
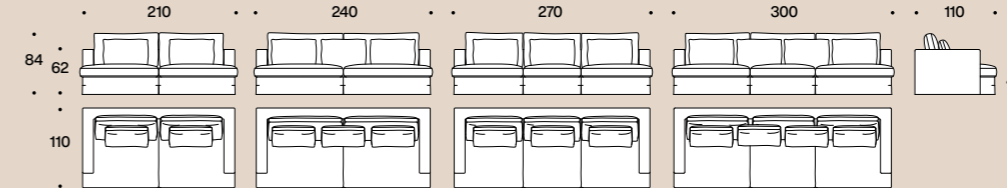

Centrali / Central units

Laterali DX-SX / Right-left side units

Terminale angolare DX-SX / Right-left corner end unit

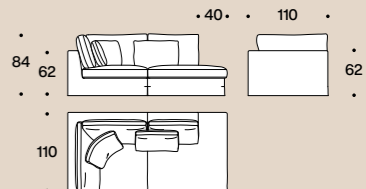
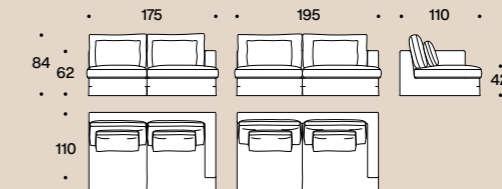
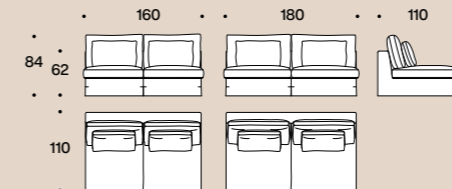

Angolare / Corner unit

Pouf

Poltrona / Armchair

Cuscino arredo / Throw cushion

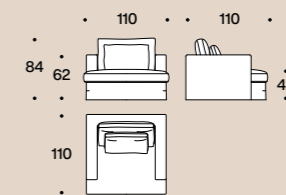
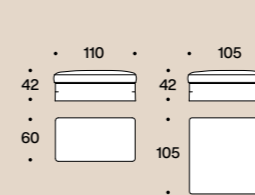
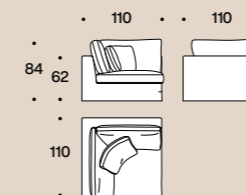

it — Con un sottile riferimento all'atmosfera retro-future dei divani da abitare degli interni anni '70, la collezione Gala, firmata Cristina Celestino, esplora la flessibilità dell'imbottito con un volume no gender, scultoreo e sofisticato, che si presta ad interpretare diverse visioni di interni, da contesti abitativi, all'hotellerie. La spina centrale è un setto verticale che disegna curve plissé pronte ad ospitare, sia sul fronte che sul retro, pouf-seduta di diverse profondità. Molteplici le configurazioni possibili che danno vita ad un divano "ibrido" e flessibile con cui interagire.

en — With a subtle reference to the retro-future atmosphere of sofas that inhabited the '70s, the Gala collection, designed by Cristina Celestino, explores the flexibility of the upholstered object with a no gender, sculptural and sophisticated volume, which lends itself to interpreting different visions of interiors, from residential to hospitality contexts. The central backbone is a vertical element that draws pleated curves ready to accommodate, both on the front as well as on the back, a seat-pouf element of different depths. The many possible configurations give life to a "hybrid" and flexible sofa with which one can interact.



p. 212 Gala - sofa system

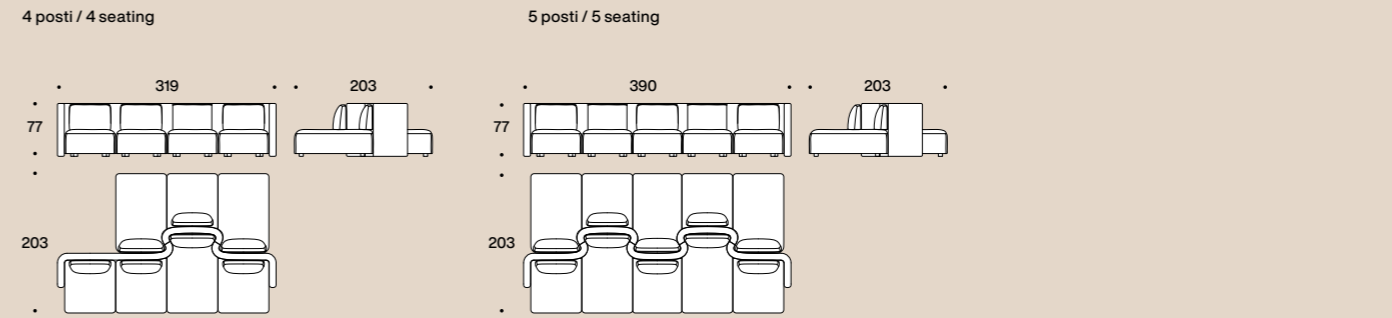
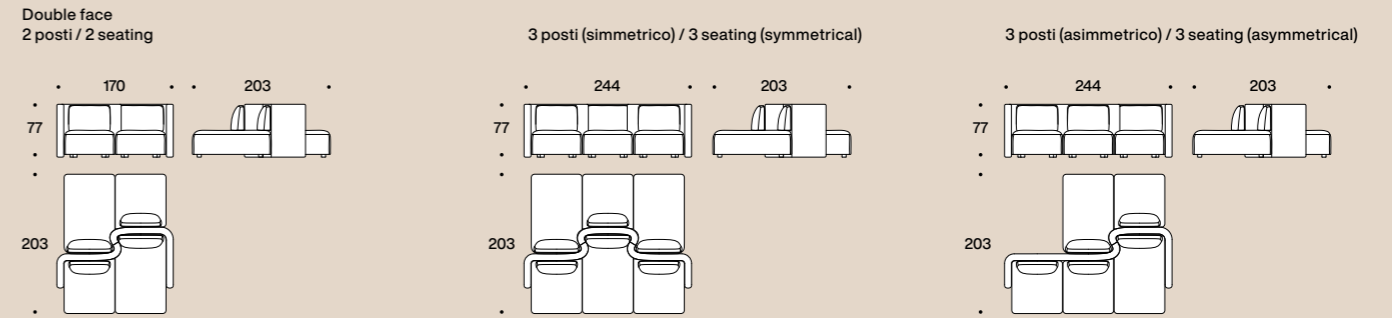
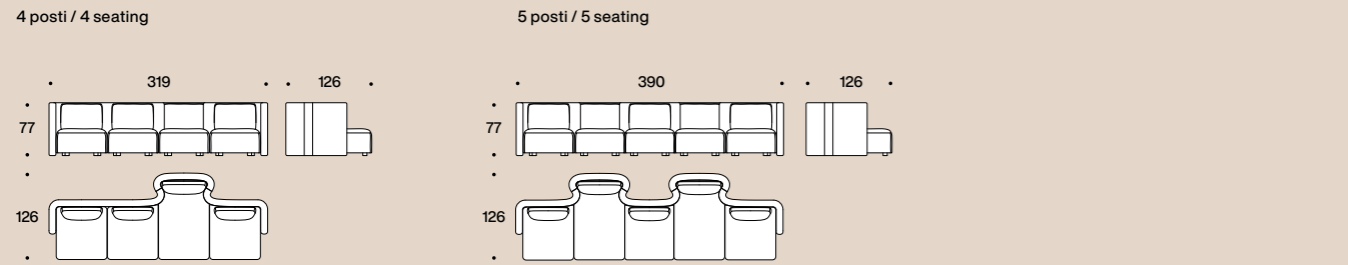
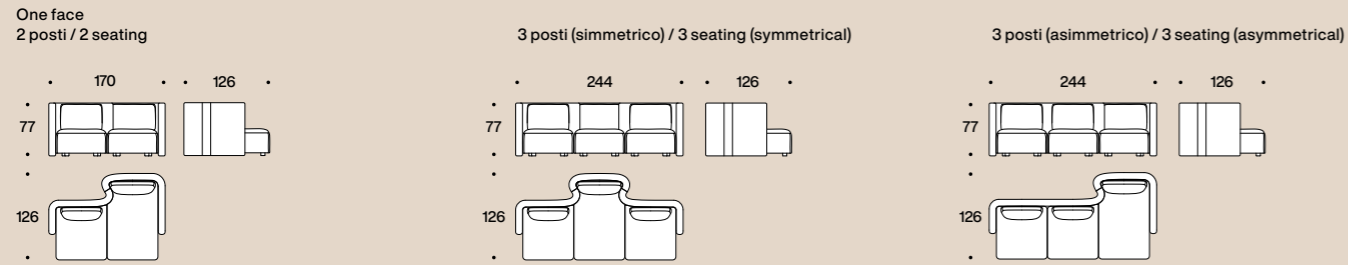

it — Rendez-vous è il sistema di sedute pensato non solo per la casa, ma anche per gli spazi collettivi. Obiettivo del progetto è consentire un'estrema flessibilità compositiva con pochi elementi di base. Il punto di partenza è una struttura metallica verniciata nera sulla quale si fissano i moduli orientandoli a propria scelta. Il risultato è un appuntamento con il piacere estetico: angoli curvi da ritmare a linee pure per disegnare ambienti di elevata personalità. I tavoli di appoggio, in due misure e due diverse finiture, sottolineano la funzione d'uso nei luoghi d'incontro. Le imbottiture rispondono già alle specifiche richieste del mondo contract e a tal fine è stata scelta parte della collezione tessile. Completamente sfoderabile.

en — Rendez-vous is the seating system envisaged not only for the home environment, but also for public spaces. The aim of the project is to allow the utmost compositional flexibility with very few elements. The starting point is a metallic black painted structure onto which various elements are fixed and can then be moved according to the user's preference. The result translates into aesthetically pleasing seating solutions: curved angles contrast with pure lines creating interiors with a strong personality. The design of the side tables, in two measurements and finishes, underlines the functional needs in places of encounter. The upholstery textile range includes the durable materials specified for use in commercial applications. Fully removable covers.



p. 228 Rendez-vous - sofa system

Esempi compositivi / Composition examples

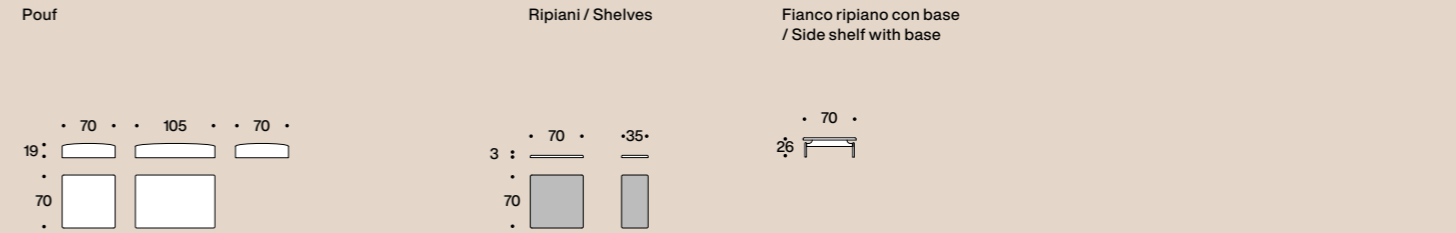
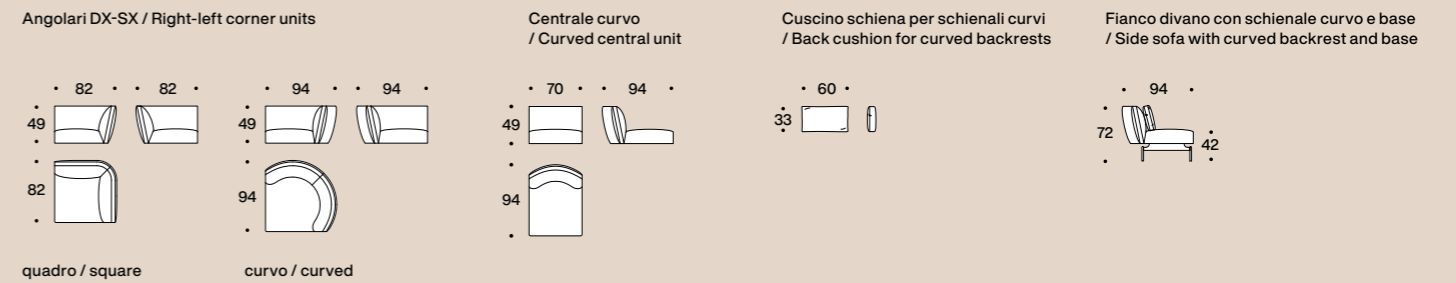
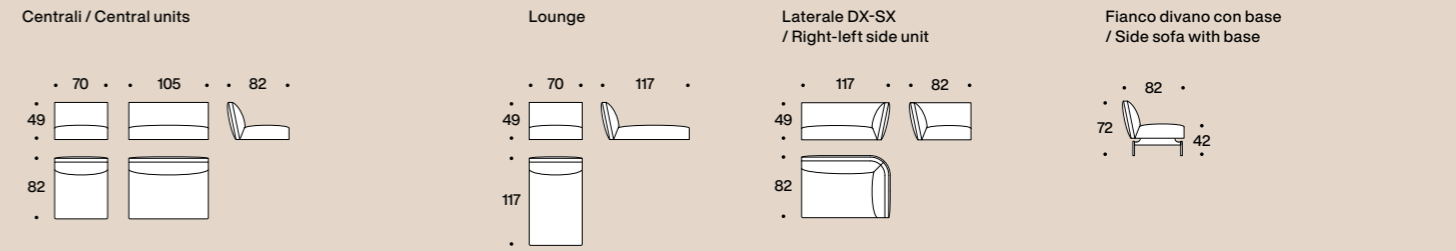
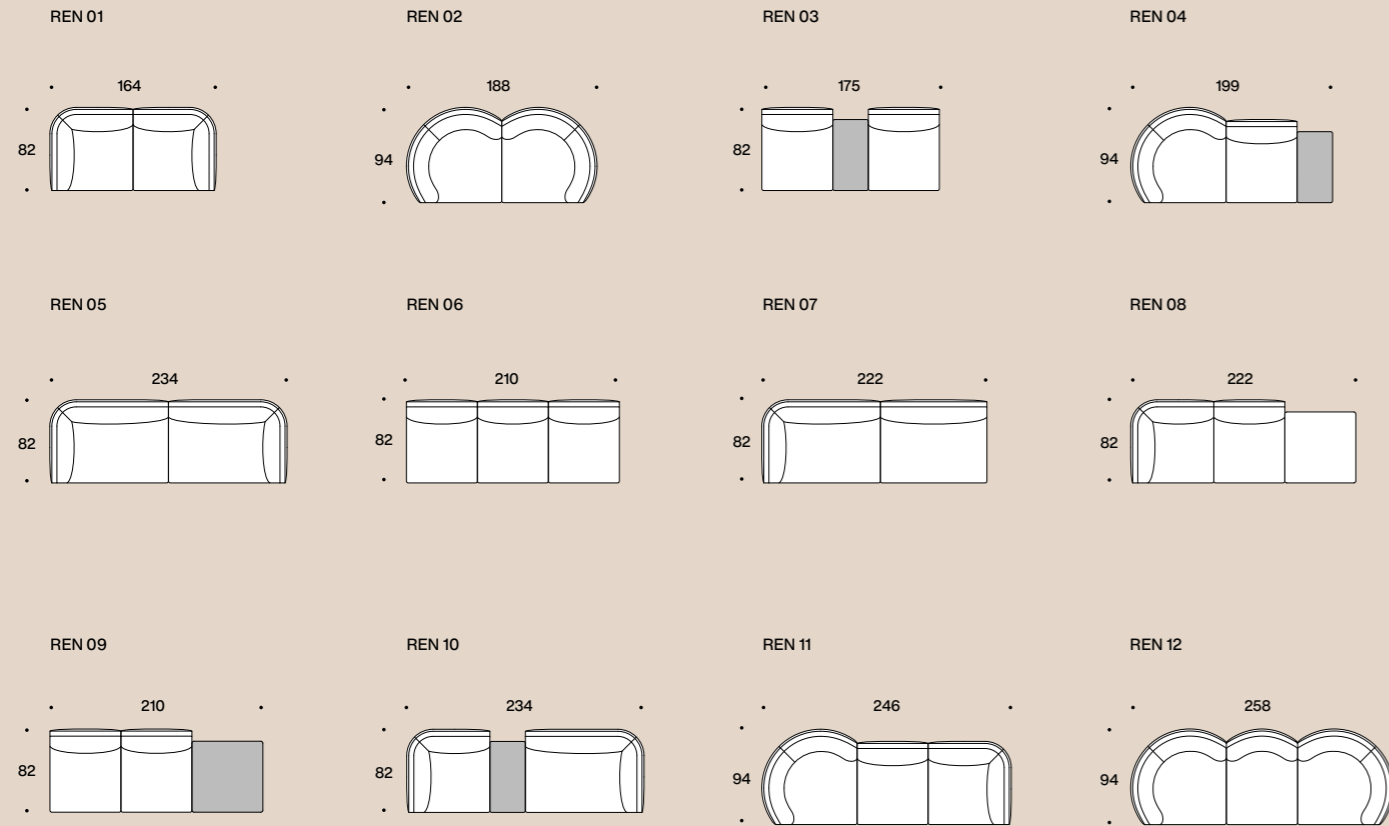

it — Il divano Up, attraverso un semplice espediente che ricorda il gioco a incastro tipico dei Lego, consente di scegliere l'altezza dello schienale che meglio corrisponde al proprio desiderio di ergonomia. L'elevazione dello schienale e il conseguente aumento della profondità di seduta, si ottengono infatti appoggiando i cuscini posteriori sopra lo schienale basso. La loro particolare forma assicura la massima stabilità. L'utilizzo della piuma d'oca in tutte le cuscinate ne rivela l'anima morbida e accogliente. Disponibile in pelle con finitura "taglio a vivo". Completamente sfoderabile.

en — The Up sofa uses a simple mechanism similar to Lego's snap-on system that allows customers to choose the height of the backrest that best satisfies their comfort requirements. The back cushions can be placed on top of the low backrest to create a deeper seat and an overall higher backrest. The particular shape of the cushions ensures maximum stability. The goose-feather padded cushions and armrests create a particularly soft, snug sofa. Also available with raw-edged leather upholstery. Fully removable covers.



p. 248 Up - sofa

Esempi compositivi / Composition examples

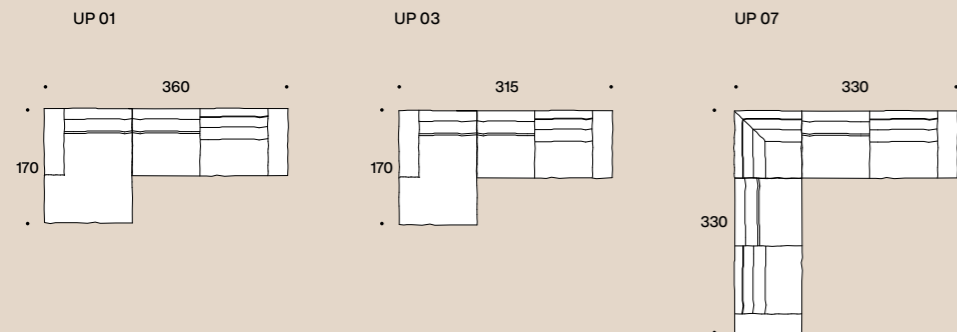

Divani / Sofas

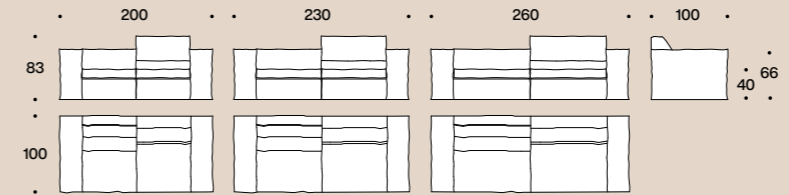

Laterali DX-SX / Right-left side units

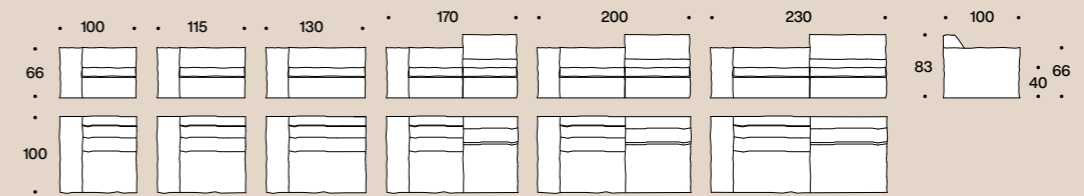

Centrali / Central units

Angolo / Corner unit

Pouf

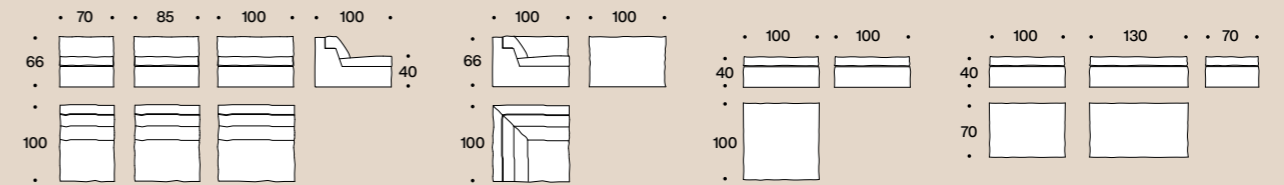

Penisole DX-SX / Right-left chaise longue

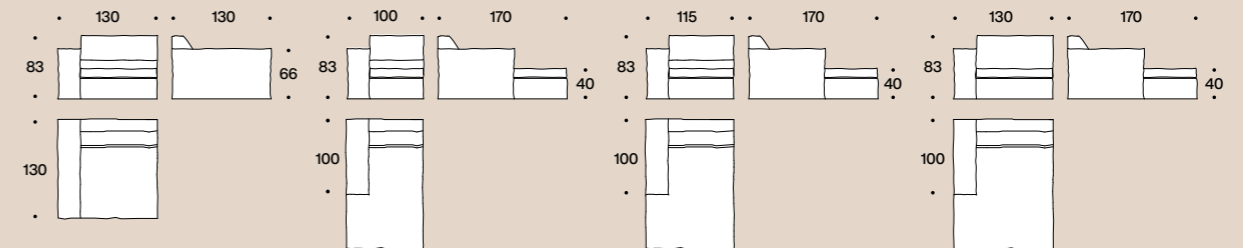

it — Essentiel si presenta con una precisa dichiarazione di intenti: un progetto privo di eccessi, dall'ergonomia accogliente, che nella mappa spazio-temporale del design congiunge idealmente l'eleganza storica italiana al tratto nordico. L'attenzione per i dettagli, che da sempre caratterizza le collezioni Saba, si ritrova nelle trapuntature dei cuscini schienale e nella profilatura in cordino di canetè. La poltrona Essentiel completa con la sua allure sofisticata questo progetto senza tempo. Completamente sfoderabile.

en — The Essentiel sofa presents itself with a clear purpose: a design without excess and comforting ergonomics, it represents a mix of Italian elegance and northern traits, merging harmonious elements in the space-time map of design. Attention to detail, a feature that has always characterized Saba's collections, can be noticed in the quilting of backrest cushions and the grosgrain cord trim. The Essentiel armchair, with its sophisticated allure, completes this timeless project. Fully removable covers.



p. 256 Essentiel - sofa



p. 372 Essentiel - armchair

Finitura piedi / Feet finish



- 1 Grigio / Grey
- 2 Verniciato Corten / Painted Corten

Divani / Sofas

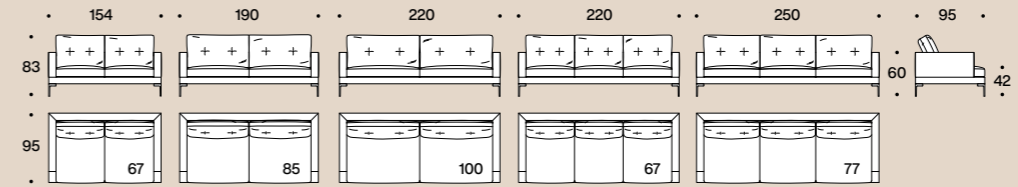

Laterali DX-SX / Right-left side units



Angolare / Corner unit

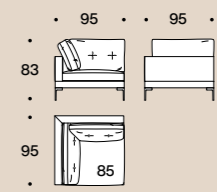

Penisole DX-SX / Right-left chaise longue

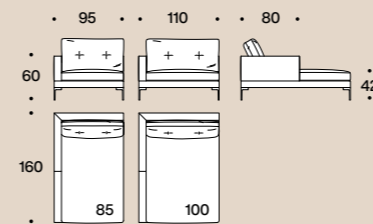

Terminale DX-SX / Right-left end unit

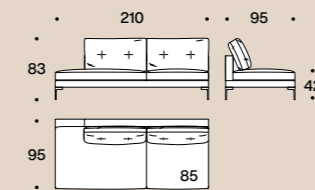

Terminale angolare DX-SX / Right-left corner end unit

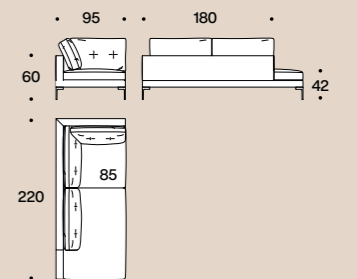

Pouf



Cuscini schiena alti / High back cushions

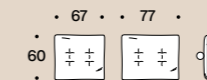

Cuscini arredo / Throw cushions



Poltrona / Armchair

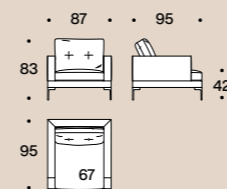

it — Livingston gioca sull'effetto sorpresa tramite un uso inaspettato del poggiatesta che, con un semplice gesto di rotazione, diventa un comodo poggiaeni. È dotato di uno schienale "intelligente" accoppiato a un cuscino più piccolo tramite semplici cerniere. La seduta, soffice e informale, dialoga con una struttura aerea in acciaio che dà slancio alla generosità delle cuscinate. La particolarità dello schienale regolabile e la caratteristica del cuscino unico di seduta conferiscono al divano Livingston Completamente sfoderabile.

en — Livingston creates a surprising effect through an unexpected use of the headrest which, by a simple rotation, becomes a comfortable backrest. It has a "smart" backrest to which a smaller cushion is attached with a zip. The soft, informal seating rests on a light steel base that creates a dynamic contrast with the generous cushions. The original, adjustable backrest and its characteristic full-length seat cushions give Livingston a unique silhouette ideally suited to creating an endless variety of arrangements. Fully removable covers.



p. 268 Livingston - sofa

Divani / Sofas

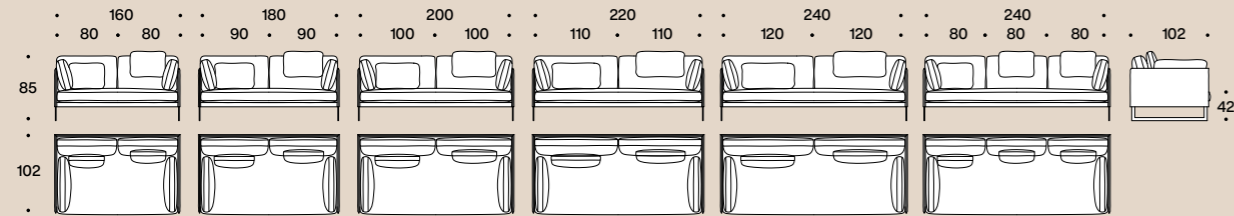

Laterali DX-SX / Right-left side units

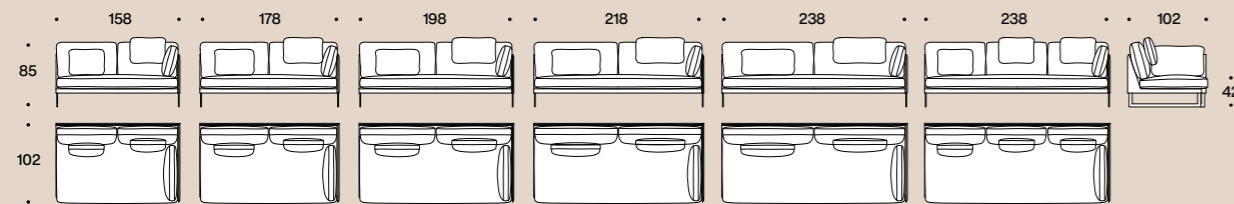

Divani angolari DX-SX / Right-left corner sofas

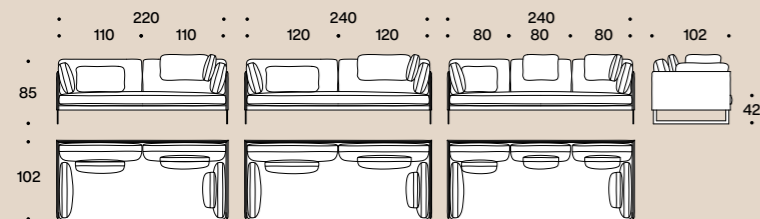

Laterali angolari DX-SX / Right-left corner side units

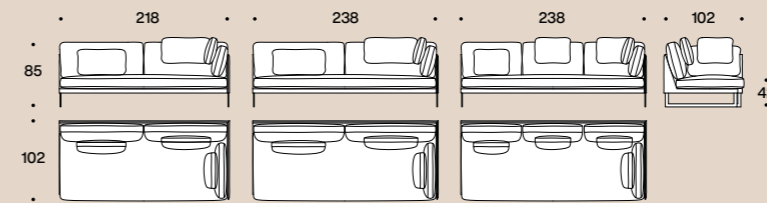

Terminali DX-SX / Right-left end units

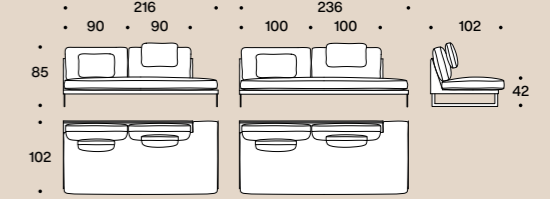

Terminali angolari DX-SX / Right-left corner end units

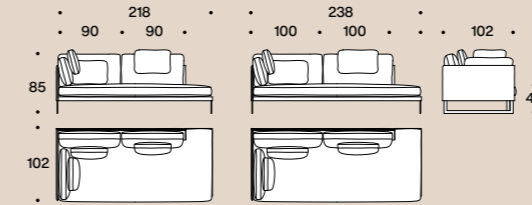

Meridienne DX-SX / Right-left Meridienne

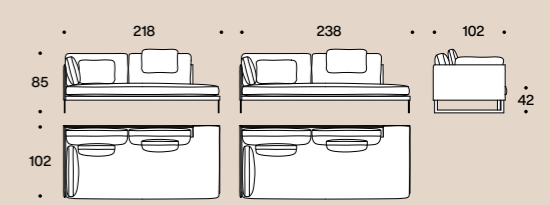

Laterale DX-SX / Right-left side unit - 110

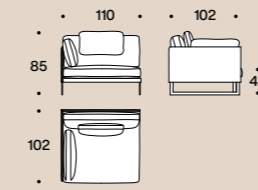

Penisola DX-SX / Right-left chaise longue - 160

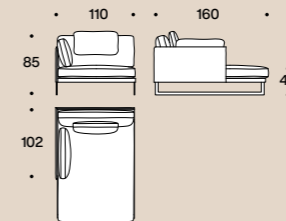

Penisola DX-SX / Right-left chaise longue - 180

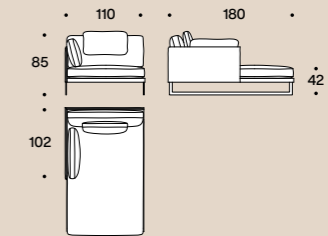

Pouf

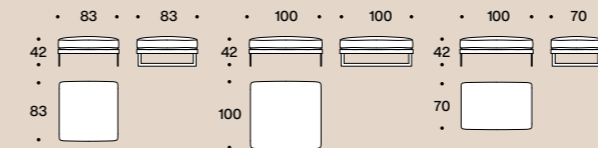

Poltrona / Armchair

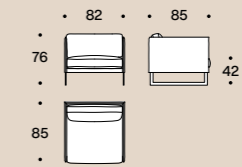

Finitura piedi / Feet finish

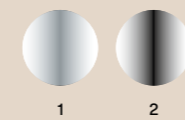

- 1 Cromo lucido / Glossy chrome
- 2 Black nichel / Black nickel

it — Geo è un progetto a tutto tondo, voluminoso ma leggero allo sguardo grazie al particolare disegno della struttura esterna. Geo è come un nido sospeso nel vuoto con piccoli rami. I volumi sono disegnati con cura e le linee avvolgono come un tenero abbraccio. Fanno parte della collezione la poltroncina Baby Geo e il pouf disponibile in tre dimensioni sia con base terra o struttura metallica. La serie pouf è disponibile anche in versione outdoor, visibile nel Volume 2. Completamente sfoderabile.

en — Geo is a well-rounded project, voluminous yet visually light thanks to the distinctive design of its external frame. Geo is like a suspended nest made of small branches. The volumes are carefully drawn, and the lines wrap you in a gentle embrace. The collection includes the Baby Geo armchair and a pouf available in three sizes, with either a floor base or a metal frame. The pouf series is also available in an outdoor version, shown in Volume 2. Fully removable covers.



p. 276 Geo - small sofa



p. 296 Geo - armchair



p. 300 Baby Geo - small armchair



p. 380 Geo - pouf

Divano / Sofa

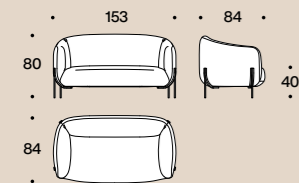

Poltrona / Armchair

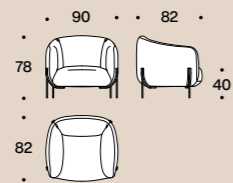

Poltroncina / Small armchair

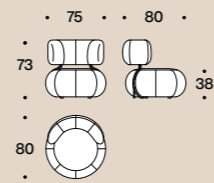

Pouf

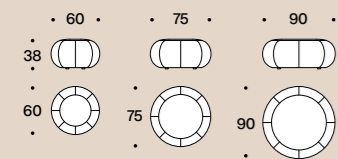

Pouf con telaio / Pouf with frame

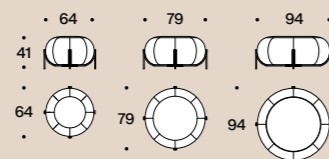

Finitura struttura / Frame finish



1 Ottone satinato / Satin brass
2 Grigio / Grey

it — Philo è il prefisso di origine greca che indica amore, propensione e simpatia verso persone o cose. Un filo metallico disegna la sintesi dell'accoglienza e sostiene delicatamente le superfici imbottite. Philo modifica con agilità le sue dimensioni per dare vita a un sistema di sedute capace di convivere con diversi ambienti: la casa, gli spazi pubblici e in generale i luoghi dell'incontro, dell'accoglienza e delle relazioni. Filantropico per natura, si veste con eleganza e semplicità, nelle sue forme asciutte e oneste. Comunica la sua empatia giocando con le linee e i colori, il filo metallico si trasforma in filo di cucitura e ancora trama e ordito, mescolate e unite in unica forma armonia. Completamente sfoderabile.

en — Philo is a prefix of Greek origins that indicates love, propensity and empathy towards people and things. A metallic thread draws the synthesis of hospitality and delicately supports the upholstered surfaces. Philo easily adjusts its dimensions to give life to a seating system capable of existing in different spaces: residential, hospitality and places of meeting in general where relationships are nourished. Philanthropic by nature this elegant and simple sofa has a lean yet grounded honest form. Its empathy is communicated with an interplay of lines and colours, the metallic thread transforms into sewing thread and continues on to weft and warp creating a singular harmony. Fully removable covers.



p. 280 Philo - small sofa



p. 332 Philo - armchair

Divani / Sofas

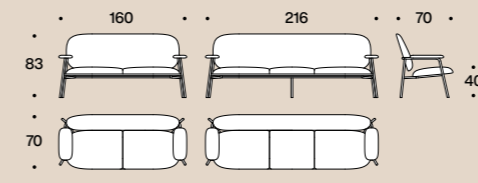

Poltrona / Armchair

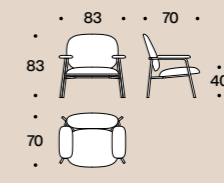

Finitura struttura opaca / Matt frame finish



1 Nero / Black

it — La collezione Kepi, si contraddistingue attraverso un design essenziale ed un'eleganza informale, perfetti sia per l'ambiente domestico che contract. La grafica struttura metallica che sostiene l'imbottitura è opzionale per la poltrona anche in frassino, offrendo così la possibilità di una connotazione leggermente nordica del prodotto, valorizzandone al contempo l'asimmetria del bracciolo. Completamente sfoderabile.

en — The Kepi collection stands out for its essential design and informal elegance, perfect for both home and contract settings. The graphic metal frame supporting the padding is also available in ash wood for the armchair, offering a slightly Nordic character and enhancing the product's asymmetrical armrest. Fully removable covers.



p. 286 Kepi - small sofa



p. 336 armchair

Divano / Sofa

Poltrona / Armchair

Pouf

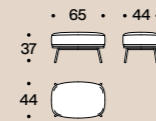
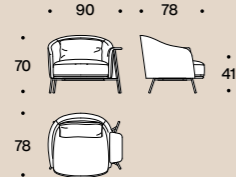
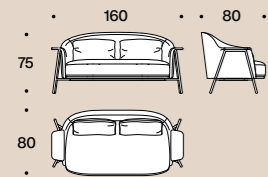

Finitura struttura in metallo / Metal frame finish

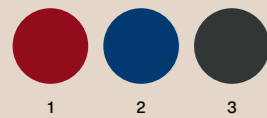

- 1 Rosso Bordeaux / Red Bordeaux
- 2 Blu Cobalto / Cobalt Blue
- 3 Grigio / Grey

Poltrona - finitura struttura in legno / Armchair - wood frame finish

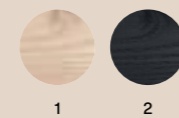

- 1 Frassino sbiancato / Blanched ash
- 2 Frassino tinto nero / Black painted ash

it — La collezione Ola si amplia con il nuovo modello di poltrona con e senza braccioli, dalle dimensioni più generose. Degna protagonista di un living sofisticato, ora è disponibile anche nella variante in tessuto trapuntato che le conferisce un'estetica ancora più avvolgente e morbida. Nata da un'idea progettuale semplice ma al contempo complessa: creare una poltrona accogliente utilizzando quattro fogli di legno curvato indipendenti tra loro, ma convergenti in un unico centro. Ola poltrona appartiene a una apprezzata collezione di sedie pranzo e sgabelli. Completamente sfoderabile.

en — The Ola collection expands with the new armchair model with more generous dimensions, available with and without armrests. A worthy protagonist of a sophisticated living room space, it is now also available in the quilted fabric variant that awards it with an even more enveloping and soft aesthetic. Ola was born from a simple yet, at the same time, complex design idea: create a welcoming armchair using four sheets of curved wood independent of each other, but converging in a single center point. The Ola armchair belongs to a popular collection of dining chairs and stools. Fully removable covers.

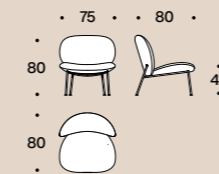

p. 304 Ola - armchair

Versione liscia / Smooth version
Poltrona / Armchair

Poltrona con braccioli / Armchair with armrests

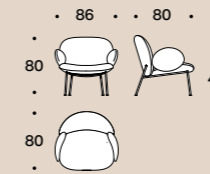
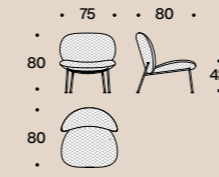
Versione trapuntata / Quilted version
Poltrona / Armchair

Poltrona con braccioli / Armchair with armrests

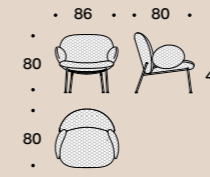

Finitura struttura / Frame finish



- 1 Ottone satinato / Satin brass
- 2 Grigio / Grey
- 3 Cromo lucido / Glossy chrome
- 4 Black nichel / Black nickel

it — La panchetta Pan Flute, nasce dall'ispirazione delle panche d'attesa da sempre presenti nelle banchine delle stazioni italiane. La grafica leggera della struttura e il ritmo essenziale dei cilindri imbottiti che ne scandiscono la seduta, contraddistinguono anche l'allure dell'omonima poltrona. Protagoniste senza essere eccentriche si prestano ad arricchire scenari domestici e contract. Completamente sfoderabile.

en — The Pan Flute bench takes inspiration from the classic waiting benches found on Italian train stations. The light frame design and rhythmic arrangement of the upholstered cylinders that form the seat also define the allure of the matching armchair. Subtle yet striking, they enrich both domestic and contract settings. Fully removable covers.



p. 308 Pan Flute - armchair



p. 394 Pan Flute - bench

Poltrona / Armchair

Panca / Bench

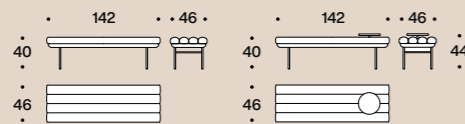
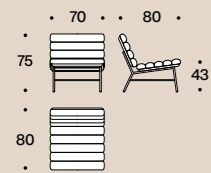

Finitura piedi-struttura / Feet-frame finish

Svuota tasche marmo / Marble tray

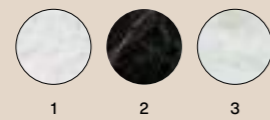

1 Black nichel / Black nickel
2 Nero opaco / Matt black

1 Bianco Carrara / White Carrara
2 Noir Antique
3 Pearl

it — Beauty è il nome della poltroncina dedicata al gesto gentile del trucco. Femminile e ironica allo stesso tempo, è dotata di una base con movimento girevole per garantire agili posizioni. Perfetta con Alphet ora accessoriatto di specchio, crea un angolo super ricercato e intimo. Del modello è disponibile anche la sola seduta cilindrica da utilizzare come pouf trasversale. Completamente sfoderabile.

en — Beauty is the name of the armchair dedicated to the gentle gesture of make-up. Feminine and ironic at the same time, it is equipped with a swivel base to ensure agile positions. Perfect with Alphet, now equipped with a mirror accessory, it creates a super refined and intimate corner. The sole cylindrical seat is available to use as a transversal pouf. Fully removable covers.



p. 316 Beauty - small armchair



p. 378 Beauty - pouf

Poltroncina / Small armchair

Finitura struttura - verniciatura opaca / Frame finish - matt painting

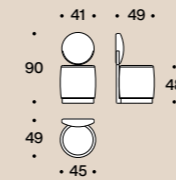

1 Nero / Black
2 Bronze Gold Matt

Pouf

Finitura base - verniciatura opaca / Base finish - matt painting

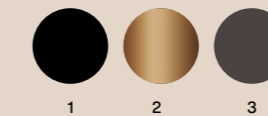
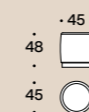

1 Nero / Black
2 Bronze Gold Matt
3 Testa di moro / Dark brown

it — La bergère Sunset si compone di una scocca e di un poggiatesta distinti per un motivo preciso: alleggerire la silhouette del prodotto creando una linea visivamente armonica. La superficie esterna tesa e rigorosa, contrasta con un'anima di cuscinate interne molto più dolci creando un disegno grafico originale. Il comfort della seduta è accentuato dal meccanismo di inclinazione, possibile solo nella variante con poggiatesta, mentre la base è dotata di meccanismo di rotazione sia per la versione "poltrona" che per la versione "bergère". Sunset combina in maniera ideale raffinato design, massimo comfort e alta qualità di materiali e lavorazioni. Completamente sfoderabile.

en — The Sunset bergère is made up of two distinct parts: the shell and the headrest for a specific reason: lighten the silhouette of the product by creating a visually harmonious line. The outdoor stretched and rigorous surface contrasts with an internal padded coat that is much softer, creating an original graphic design. The comfort of the seating area is accentuated by the reclining mechanism, available only in the variation with the headrest, whereas the base is equipped with a rotation mechanism both for the armchair and the bergère version. Sunset combines in an ideal way sophisticated design, maximum comfort and high-quality materials and techniques. Fully removable covers.



p. 326 Sunset - armchair



p. 328 Sunset - bergère

Poltrona / Armchair

Bergère

Pouf

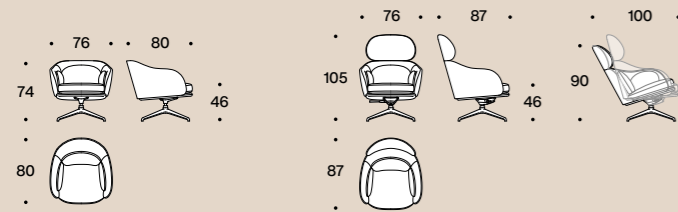

Finitura struttura / Frame finish



- 1 Alluminio lucidato / Glossy aluminum
- 2 Nero opaco / Matt black
- 3 Champagne

it — Poltroncina dalla forma lieve che ricorda l'accoglienza di una piuma, una carezza, una parentesi di armonia realizzata in frassino verniciato e corda nautica intrecciata. Il nome, che ha origini persiane "seh-tar", significa letteralmente tre corde e trova fonte di ispirazione nello strumento della musica classica indiana più conosciuto in Occidente. Un background lontano per un appeal senza tempo e un design contemporaneo.

en — A light armchair that brings to mind the softness of a feather, a caress, a moment of harmony in ash wood and woven nautical cords. The name has Persian origins "seh-tar" literally means three strings and the model is inspired by the best known Indian classical music instrument. Faraway origins generating timeless appeal for a modern design.



p. 342 Sitar - armchair

Poltrona / Armchair

Pouf

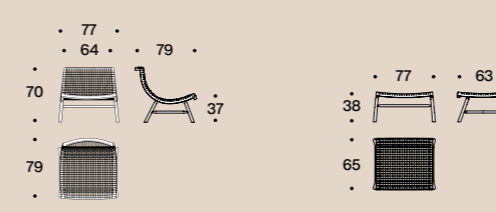

Finitura struttura / Frame finish

Finitura intreccio / Braid finish



- 1 Frassino tinto noce / Walnut painted ash
- 2 Frassino tinto nero / Black painted ash
- 1 Monocolore Corda / Monocolor Cord
- 2 Bicolore Corda&Nero / Bicolor Cord&Black
- 3 Bicolore Grigio&Nero / Bicolor Grey&Black

it — La poltrona Fleur si ispira alla grazia di un fiore e introduce la struttura cantilever all'interno della collezione Saba. Pur rispettandone la funzionalità classica, garantendo molleggio e flessibilità di seduta, si distingue per l'allure aggraziata. Completamente sfoderabile.

en — The Fleur armchair is inspired by the delicate form of a flower and it introduces the cantilever structure in the Saba collection. Despite the traditional cantilever function, ensuring a springy and flexible seat, it is distinguished for its graceful allure. Fully removable covers.



p. 348 Fleur - armchair

Poltrona / Armchair

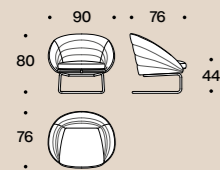

Finitura struttura / Frame finish

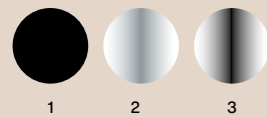

- 1 Nero opaco / Matt black
- 2 Cromo lucido / Glossy chrome
- 3 Black nichel / Black nickel

it — Avvolgente come una musica d'ambiente, Chillout esplora la tendenza del design di rendere contemporaneo un pensiero classico. Il progetto, che porta la firma del designer Giuseppe Viganò, si ispira a un'idea di living informale e reinterpreta il design anni '50 con le sue linee sinuose. Piccoli accorgimenti sartoriali e l'originale bracciolo, donano a Chillout un'immagine armoniosa e la rendono una seduta estremamente confortevole. Snella eppure accogliente, con la sua silhouette avvolgente dal sofisticato sapore retrò, ha il fascino unico dell'handmade. Un prodotto passepartout, perfetto in ogni ambiente, da quello domestico casa agli spazi contract. Completamente sfoderabile.

en — As soothing as background music, Chillout explores the design trend that recreates old classics with a modern twist. Designed by Giuseppe Viganò, the project draws its inspiration from informal living areas and with its sinuous lines, it reinterprets a design typical of the 50s. Sharp tailoring details and an original armrest give Chillout a balanced appeal and make for a highly comfortable seat. Slender yet inviting with a sleek retro feel, it oozes the unique allure of handmade objects. From home interiors to contract projects, this is an all-purpose product which perfectly fits into any surroundings. Fully removable covers.



p. 352 Chillout - armchair

Poltrona / Armchair

Pouf

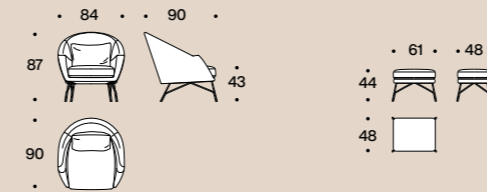

Finitura piedi / Feet finish



- 1 Black nichel / Black nickel

it — Chance è una poltroncina girevole dalle dimensioni contenute, adatta a prestarsi come elemento funzionale - decorativo in ogni contesto abitativo e contract. Una forma senza tempo, la cui anima si rivela di volta in volta attraverso l'abito di cui si riveste. Completamente sfoderabile.

en — Chance is a compact swiveling tub chair, equally functional and decorative in both domestic and contract settings. The perfectly round timeless shape can reveal many different souls depending on the chosen textile. Fully removable covers.



p. 356 Chance - armchair

Poltrona / Armchair

Finitura base girevole / Swivel base finish

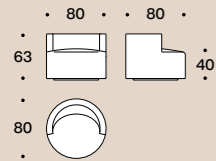

1 Cromo lucido / Glossy chrome

it — Deliziosa e aggraziata, la poltroncina Amélie rimanda all'haute couture francese. La particolare trapuntatura che sottolinea le curve interne è realizzata a mano seguendo uno schema non casuale. Contenuta ma di forte appeal, si presta ad arredare qualsiasi spazio in cui ci sia l'esigenza di una seduta. Le cuciture trapuntate possono a scelta essere commissionate a contrasto, in un gioco di personalizzazione infinito. Colore su colore per Amélie: le nuances di tendenza ne esaltano le forme sinuose. Disponibile anche con base girevole, completamente sfoderabile.

en — Delightfully pretty, the Amélie tub chair conjures up visions of French haute couture. The inner curves have been deliberately emphasised by a clever, hand-quilted, pattern effect. Compact yet with a strong appeal, Amélie would be an attractive addition to any space where seating is required. The quilted stitching can be ordered in a contrasting colour, offering endless possibilities to suit personal choice. Tone-on-tone for Amélie: the latest hues give prominence to its graceful lines. Also available with a swivel base, fully removable covers.



p. 360 Amélie - small armchair

Poltroncina / Small armchair

Finitura base girevole / Swivel base finish

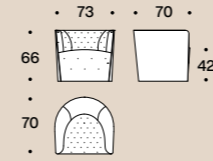

1 Cromo lucido / Glossy chrome

it — Forme eleganti e sinuose per Bustier, una poltrona che trae ispirazione dai busti avvolgenti delle dame ottocentesche. Bustier si compone di una scocca rigida che abbraccia soffici cuscini in piuma, prestando le sue forme a innumerevoli cambi d'abito e interpretazioni. La collezione tessuti di Saba, unica nel suo genere, interpreta in modo eclettico Bustier per arredare, decorando, sia zone living che contract. Disponibile anche con base girevole. Completamente sfoderabile.

en — Bustier's elegant, curvy shape was inspired by the body-hugging corsets worn by ladies in the 19th century. Bustier is composed of a rigid shell that embraces soft feather cushions, its shape can adapt to many different covers and interpretations. Saba's unique fabric collection interprets Bustier in an eclectic way, to furnish and decorate both residential or contract environments. Also available with a swivel base. Fully removable covers.



p. 364 Bustier - armchair

Poltrona / Armchair

Finitura base girevole / Swivel base finish

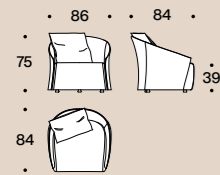

1 Cromo lucido / Glossy chrome

it — La doppia anima, maschile e femminile al tempo stesso di No logo Light, consente a questa poltrona di convivere sia negli ambienti domestici, che negli spazi pubblici e più rigorosi. Risalta in particolare, il contrasto tra l'austerità della struttura in acciaio e la sorprendente comodità dell'accogliente seduta. No logo Light si pone con carattere al centro del vivere quotidiano, con discrezione. Completamente sfoderabile.

en — No Logo Light exhibits a double soul, both masculine and feminine, that allows it to fit into residential spaces as well as into the most rigorous of public areas. Its most striking features are the austerity of the steel frame and the unexpectedly comfortable seat cushion. No Logo Light places itself squarely at the center of everyday life, yet with the utmost discretion. Fully removable covers.



p. 368 No Logo Light - armchair

Poltrona / Armchair

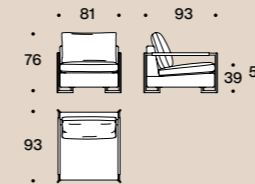

Finitura struttura / Frame finish



1

1 Black nichel / Black nickel

Bracciolo - finitura profilo in cuoio / Armrest - leather profile finish



1

2

1 Nero / Black
2 Testa di moro / Dark brown

it — Island è una collezione composta da tre pouf le cui forme organiche richiamano le linee curve delle coste lambite dal mare. Il rimando si fa sentire non solo in pianta, ma su tutte le dimensioni, a ricordare il movimento avvolgente dell'acqua che leviga e modella le pietre. Per questo motivo, i volumi, vengono percepiti in maniera differente nello spazio a seconda della prospettiva da cui vengono osservati. Lo zoccolo stacca visivamente la seduta da terra e la lascia fluttuare nello spazio. Completamente sfoderabile.

en — Island is a collection made up of three poufs with organic forms that evoke the coast line lapped by the sea. This imagery is felt throughout the entire design, conjuring the enveloping movement of the tide which softens and shapes the shore. For this reason, the volumes are perceived differently depending on the perspective from which they are observed. The base visually elevates the seat from the ground making it seem like it's floating in space. Fully removable covers.



p. 382 Island - pouf

Pouf

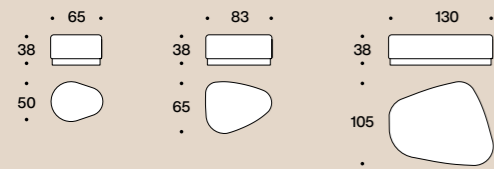

Finitura base / Base finish



1

1 Verniciato ottone / Painted brass

it — Il pouf Cookie è disponibile in formato rotondo o quadrato ed è caratterizzato da un'evidente ma leggera trapuntatura sulla seduta. Cookie è un pouf versatile, può esistere in modo indipendente ma si presta anche ad essere accostato ad altri elementi. Completamente sfoderabile.

en — The Cookie pouf is available in a round or square format and is characterized by a delicate yet evident quilting on the seating area. Cookie is a versatile pouf that can exist on its own or be placed nearby other products. Fully removable.



p. 384 Cookie - pouf

Pouf

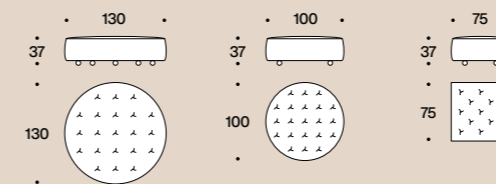

Thanks to:

6 am
Agustina Bottoni
Alan Sbaffi
Alcova
Alice Reina - biancodichina
Alimonti
altreforme
Amini
Andlight
Andres Sal Silla
Antonio Marras
Aponte Boretti
Artemide
Astep
Atelier Areti
Atelier Vetra
Axolight
AYTM
Barbara Schweizer Edizioni
Basis
Besana Moquette
Bitossi Ceramiche
Bloc Studios
Blueside
Bosa
Cara Davide
CC Tapis
Ceramicah
Chiara Berta
Claire Lune Lab
Coki Barbieri
Contardi Lighting
Crafting Plastic
Cto lighting
Cuore Carpenito
Danese Milano
Daniele Giannetti
Daria Dazzan
Davide Groppi
Desalto
DESIGN EDITIONS
Domenico Orefice
Eligo
Enrico Donadello
Federica Biasi
Fiandre Surfaces
Fibra Research
Flos

Forever Studio
Fornace Brioni
Francesco Ardini
Francesco Pedraglio
FROM LIGHTING
Gaetano di Gregorio
Gan
Giada Tremolada
Giobagnara
Giulia Cosenza
Golran
Grok Lighting
Hasik Design Studio
Helle Mardahl
Il Fanale
IVV Cristallerie
JCP
Jon Thomas
Kaia Lighting
Karpeta
La fucina di Efestò
LATOxLATO
Laura Ramirez
Lavinia Fantappiè Ceramics
Lea Studios
Leds C4
Leucos
Lumina
Maddalena Selvini
Maison Domino
Manerba
Manfredi Style
Maria Ibor Guerrero
Marina Annousi
Marsell
Martinelli Luce
Masiero
Mason Editions
Matete Martini
MBAE Studio
Merve Kahraman
Michela Grossi
Micheluzzi Glass
Milan Illuminacion
Mingardo
Miniforms
MM Lampadari
MMairo

Mutina Edizioni
Nahoor
Niva Design
Oluce
Panzeri
Paola C.
Pentalight
PIETRACHIARA
Pietre trovanti
Potafiori
Pretziada
Pulpo
Raquel Munos Soriano
Residenza Location
Restart Milano
Rito Collection
Rubelli
Salvatori
SEM Milano
Serena Confalonieri
SERVOMUTO
Sika
Simona Cardinetti
Slalom
Society Limonta
Stefania Loschi
Studio Formart
Studio Intervallo
Studio Sonia Pedrazzini
Studio Terre
Tato Italia
Tellurico
TIPIQA
Tom Rossau
Tooy
Tubes Radiatori
Up Group
Vero International
Vesta Furniture
Vetrofuso
Vito Nesta
Yali Glass
Zanellazine
ZAVA luce
Zieta
ZPSTUDIO

A special thanks to all the galleries that collaborated by providing the artworks in this catalogue:

10 am Gallery
antigallery
APalazzo Gallery
Camp Design Gallery
Castiglioni Fine Arts Gallery
Dep Art Gallery
ESH Gallery
Galleria G7
Galleria P420
Galleria Rossana Orlandi
Galleria Spazia
Nordés Gallery
Nous Art Gallery
Prometeo Gallery
Studio Gariboldi Gallery
Suprainfinit Gallery
VV8 Arte Contemporanea

Project managers

Amelia Pegorin
Alessandra Santi
Chiara Fiscon

Set Design

Alessandra Salaris
Greta Cevenini
Studio MILO

Photography

Beppe Brancato
Contratti Company
Claudio Rocci
Mattia Balsamini

Graphic Design

Designwork

Made and printed in

Italy, July 2025

by Grafiche Antiga



Saba Italia

35018 S. Martino di Lupari
Padova / Italy
via dell'Industria, 17
T +39 049 946 2227
F +39 049 946 2219
infosaba@sabaitalia.com
sabaitalia.com

sabaitalia.com