



Petite Friture

US CATALOGUE 2026



Petite Friture has made a name for itself as a design editor like no other, a universe to lived in with a wholly independant style and tone.

Petite Friture is an expression of unique encounters, intuition, and revelations. Challenge norms. Question the obvious. Take the path less trodden. Curate to achieve fulfilment for ourselves and others. On the cusp of audacity and modernity.

Each encounter is a first step on a new journey. Each project is a challenge to overcome for talented designers and creators, united by the demands of success and a shared understanding of beauty.

Since 2010, their collaborative effervescence has seen Petite Friture create iconic pieces like Constance Guisset's feather-light vertigo suspension, the outdoor furniture line week-end with studio BrichetZiegler, and many other pieces with up-and-coming designers and well-respected studios alike.

Petite Friture is proud to take a stand, to seek out the best solutions at every step of the way, to use the right techniques and right people to better serve the planet and do something good. From an effervescent blend comes a sense of drive, a desire to work towards something sincere.

Transparency, respect, dialogue – our brand is one that seeks a sustainable future for decades to come. Its ambition is to create virtuous beauty that will last for many years to come. In 2023 Petite Friture became a purpose-driven company. Our mission: contribute, through our collections, to making good out of beauty.

01

LIGHTING

Neotenic
Brush
Quasar
Vertigo Nova
Vertigo
Mediterranea
Cherry
Unseen

02

FURNITURE

Sandows
Eclipse
Fromme
Fromme Wood
Week-End
Francis
Wander

03

UPHOLSTERY

Lily
Hoff

04

DECORATION

Donut
Bubble
Shades of time
Courtyard



01 LIGHTING



NEOTENIC

JUMBO

Born of the first collaboration between Petite Friture and Studio Jumbo, NEOTENIC's daring lines are bound to seduce. Its round, generous shapes reference the reassuring aesthetics of childhood. A true display of expert craftsmanship and technique that defy the laws of physics.

Environment: indoor
Bulb lighting



NEOTENIC

JUMBO

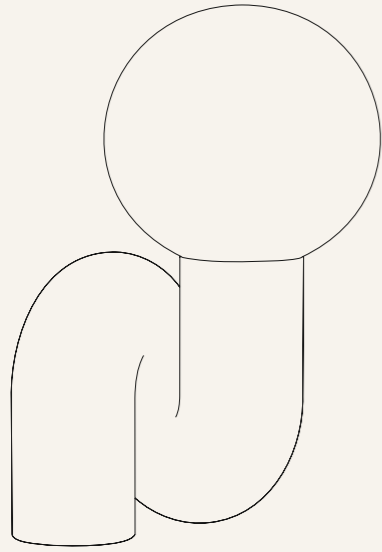

LARGE TABLE LAMP

Materials: ceramic, glass

Dimensions: L13,4 in x H20,1 in

Weight: 14,6 lb

Technical specificities: IP20, dimmable, E26 socket (bulb advice: 2700K, 1000lm, ø55mm max), 60Hz, 110-120V

Certifications: CE, UKCA, UL

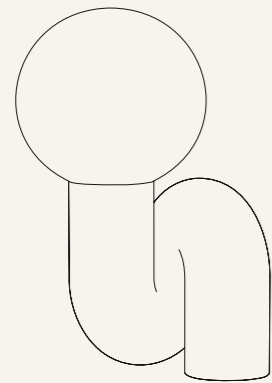

SMALL TABLE LAMP

Materials: ceramic, glass

Dimensions: L7,1 in x H10,2 in

Weight: 3,5 lb

Technical specificities: IP20, dimmable, G9 socket (bulb advice: 2700K, 500lm), 40W max, 60Hz, 110-120V

Certifications: CE, UKCA, UL



BRUSH

PIERRE CHARRIÉ

The Brush pendant light collection by Pierre Charrié involves working with the colour as an essential component of an object in relationship to the shape. The collection incorporates a selection of precious and highly technical pigments (ground mother-of-pearl) that gives the lamps a unique iridescent glow. Brush is a melding of geometric and organic lines.

Environment: indoor
Bulb lighting



[Back to summary](#)



BRUSH

PIERRE CHARRIÉ

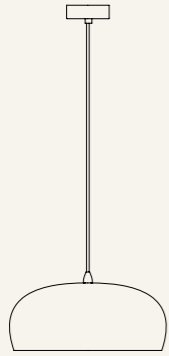

SMALL PENDANT LIGHT

Materials: ceramic, glass

Dimensions: Ø13,8 in x H5,9 in

Weight: 4,2 lb

Technical specificities: IP20, dimmable, E26 socket (bulb advice: A or G shape, H11cm max, 2700K, 1500lm), 40W max, 60Hz, 110-120V

Certifications: CE, UKCA, UL

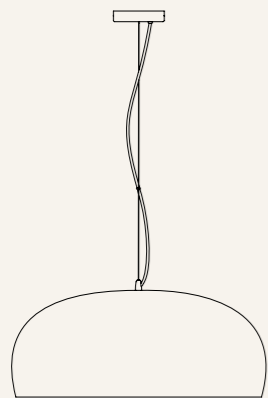
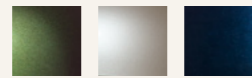

LARGE PENDANT LIGHT

Materials: ceramic, glass

Dimensions: Ø23,6 in x H9,8 in

Weight: 10,8 lb

Technical specificities: IP20, dimmable, E26 socket (bulb advice: H20cm max, 2700K, 3000lm), 40W max, 60Hz, 110-120V

Certifications: CE, UKCA, UL

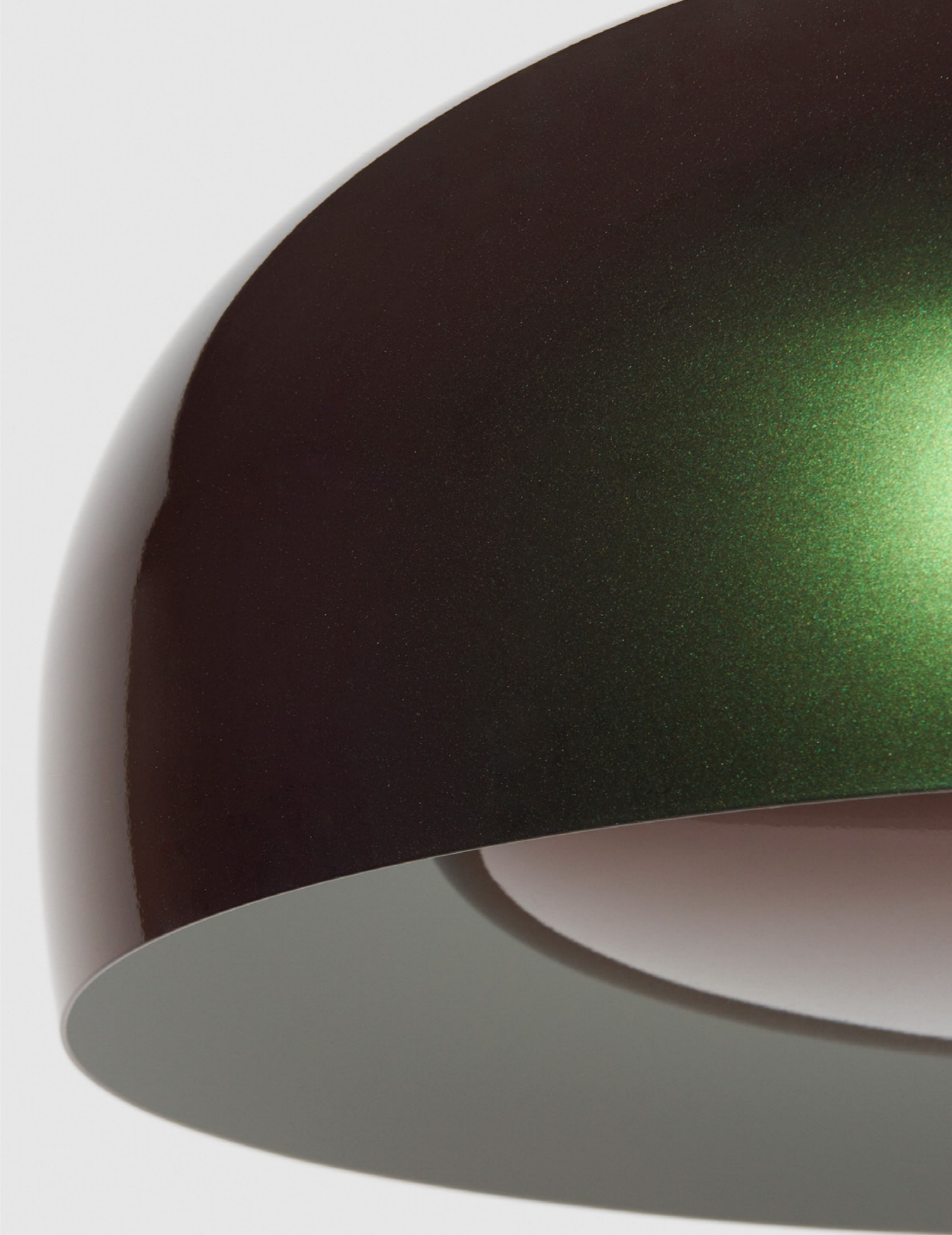
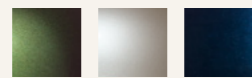

QUASAR

SAMY RIO

A contraction of 'Quasi-stellar', Samy Rio's portable QUASAR lamp reflects the designers lie on the move, spent between time in the city and the great outdoors. Quasar is a cordless lamp that sheds light into your world. The powder-coated aluminium, circular shapes, and multicoloured rope give the lamp a fun, playful feel.

Environment: indoor and outdoor
LED lighting



QUASAR

SAMY RIO

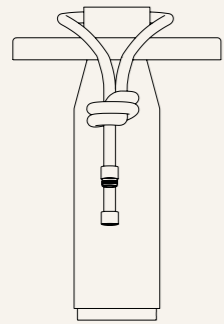

PORTABLE LAMP

Materials: aluminum, plastic, braided polyester

Dimensions: Ø6,7 in x H10,2 in

Weight: 2,9 lb

Technical specificities: dimmable, 2W, CRI 80+,
2200/3000/4000K, 173/213/240lm, IP54, 5V

Certifications: CE, UKCA, FCC



VERTIGO NOVA

*CONSTANCE
GUISSET*

Petite Friture and Constance Guisset joined forces for a second time round as they enter a new chapter with VERTIGO NOVA: bold technical choices in a style that is as poetically elegant as ever. The latest creation incorporates LED technology inside blown-glass sphere that diffuses a soft, dimmable light.

Environment: indoor
LED lighting



VERTIGO NOVA

CONSTANCE

GUISSET

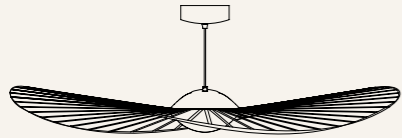

SMALL PENDANT LIGHT

Materials: fiberglass, steel, polyurethane ribbons, glass triplex, aluminium, mesh textile
Dimensions: Ø43,3 in x H4,5 in
Weight: 4,4 lb
Technical specificities: 10W, CRI 85+, 2700K, 1350lm, IP20, 60Hz, 110-120V
Certifications: CE, UKCA, UL

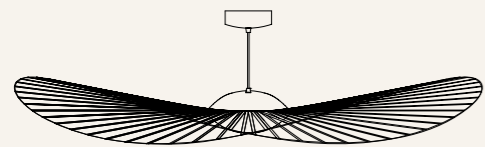

MEDIUM PENDANT LIGHT

Materials: fiberglass, steel, polyurethane ribbons, glass triplex, aluminium, mesh textile
Dimensions: Ø55,1 in x H4,7 in
Weight: 5,5 lb
Technical specificities: 10W, CRI 85+, 2700K, 1350lm, IP20, 60Hz, 110-120V
Certifications: CE, UKCA, UL

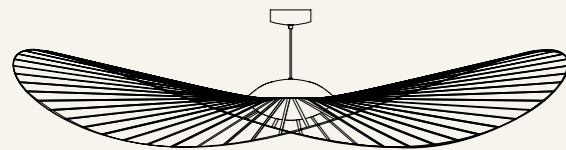
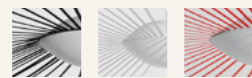

LARGE PENDANT LIGHT

Materials: fiberglass, steel, polyurethane ribbons, glass triplex, aluminium, mesh textile
Dimensions: Ø74,8 in x H5,2 in
Weight: 6,8 lb
Technical specificities: 10W, CRI 85+, 2700K, 1350lm, IP20, 60Hz, 110-120V
Certifications: CE, UKCA, UL

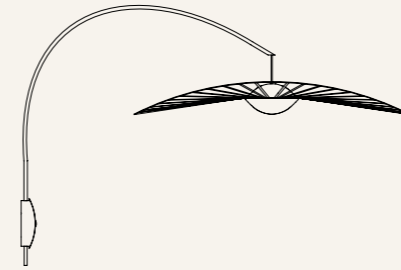
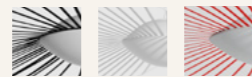

WALL LAMP

Materials: fiberglass, steel, polyurethane ribbons, glass triplex, aluminium, mesh textile
Dimensions: Ø43,3 in x H40,9 in
Weight: 7,1 lb
Technical specificities: 10W, CRI 85+, 2700K, 1350lm, IP20, 60Hz, 110-120V
Certifications: CE, UKCA, UL

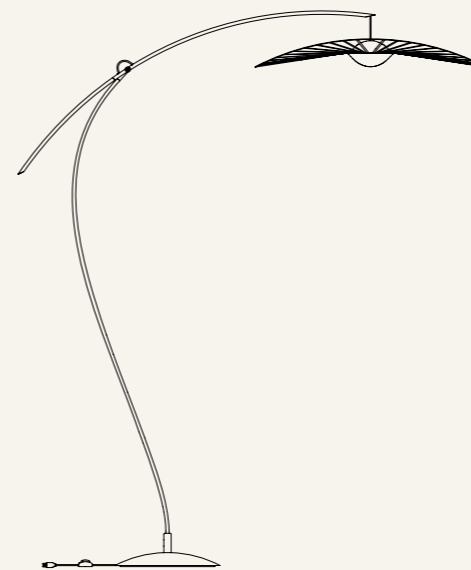
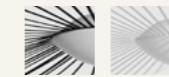

FLOOR LAMP

Materials: fiberglass, steel, polyurethane ribbons, glass triplex, aluminium, mesh textile
Dimensions: Ø43,3 in x H90,6 in
Weight: 44,1 lb
Technical specificities: 10W, CRI 85+, 2700K, 825lm, IP20, 60Hz, 110-120V
Certifications: CE, UKCA, UL

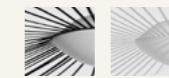

VERTIGO

CONSTANCE
GUISSET

First released in 2010, the VERTIGO pendant light by Constance Guisset has become an icon of contemporary design. VERTIGO could be described as a 'cabin lamp': it's combination of weightlessness and graphic lines, well suited to both small and large spaces, helps create its own intimate space. With its ultra-light fibreglass structure pulled tight by velvety, the Vertigo lamp seemingly comes to life in a fascinating dance as it is gently rocked by the natural flow of air.

Environment: indoor
Bulb lighting



VERTIGO

CONSTANCE
GUISSET

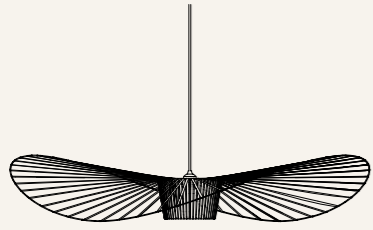

SMALL PENDANT LIGHT

Materials: fiberglass, steel, polyurethane ribbons

Dimensions: Ø43,3 in x H4,7 in

Weight: 0,7 lb

Technical specificities: dimmable, E26 socket (bulb advice: G60, 1500lm, 2700K), 40W max, IP20, 60Hz, 110-120V

Certifications: CE, UKCA, UL

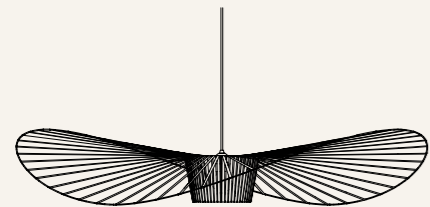

MEDIUM PENDANT LIGHT

Materials: fiberglass, steel, polyurethane ribbons

Dimensions: Ø55,1 in x H5,9 in

Weight: 1 lb

Technical specificities: dimmable, E26 socket (bulb advice: G90, 1500lm, 2700K), 40W max, IP20, 60Hz, 110-120V

Certifications: CE, UKCA, UL

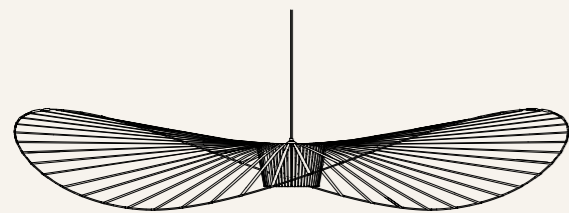

LARGE PENDANT LIGHT

Materials: fiberglass, steel, polyurethane ribbons

Dimensions: Ø78,7 in x H6,7 in

Weight: 1,6 lb

Technical specificities: dimmable, E26 socket (bulb advice: G120, 1500lm, 2700K), 40W max, IP20, 60Hz, 110-120V

Certifications: CE, UKCA, UL



MEDITERRANEA

*NOÉ DUCHAUFOUR
-LAWRENCE*

Inspired by the weightlessness “of laundry billowing in mediterranean balconies” Noé Duchaufour-Lawrance designs MEDITERRANEA, a series of light in brass and led. The collection is part of the designer’s approach who, through his projects, attempt to accompany the users in the quest to be better, by associating the functionality of an object or place to the research of an experience linked to its use.

Environment: indoor
LED lighting



MEDITERRANEA

NOÉ DUCHAUFOUR -LAWRENCE



SMALL PENDANT LIGHT

Materials: brushed brass

Dimensions: L39,6 in x W7,1 in x H5,9 in

Weight: 8,8 lb

Technical specificities: dimmable, 10W, CRI 90+, 2700K, 936lm, IP20, 60Hz, 110-120V

Certifications: CE, UKCA, UL

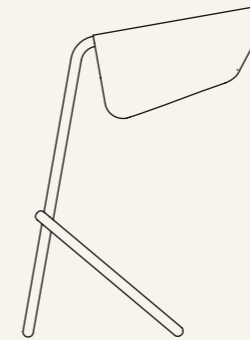

TABLE LAMP

Materials: brushed brass

Dimensions: L13 in x W8,3 in x H17,5 in

Weight: 2,9 lb

Technical specificities: 3W, CRI 90+, 2700K, 216lm, IP20, 50/60 Hz, 110-120V

Certifications: CE, UKCA, UL

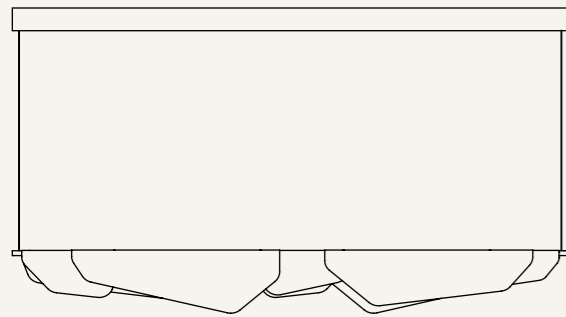

LARGE PENDANT LIGHT

Materials: brushed brass

Dimensions: L63 in x W9,8 in x H5,9 in

Weight: 13,2 lb

Technical specificities: dimmable, 17W, CRI 90+, 2700K, 1620lm, IP20, 60Hz, 110-120V

Certifications: CE, UKCA, UL

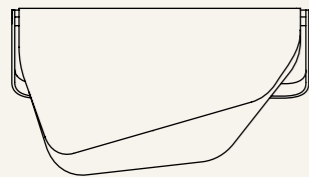

WALL LAMP

Materials: brushed brass

Dimensions: L13,4 in x W7,9 in x H5,9 in

Weight: 2,2 lb

Technical specificities: 4W, CRI 90+, 2700K, 234lm, IP20, 60Hz, 110-120V

Certifications: CE, UKCA, UL



CHERRY

*DANIEL
ET EMMA*

Australian design duo Daniel and Emma are behind the range of simple, minimalist pendant lamps known as CHERRY. The aluminium cone floating above a sphere with a mirror-like finish is a curious combination that evokes childhood memories of ice-cream cones.

Environment: indoor
LED lighting



SMALL PENDANT LIGHT

Materials: aluminium, matt grained, steel, plexiglass, fabric cable

Dimensions: Ø6,3 in x H14,8 in

Weight: 2,6 lb

Technical specificities: dimmable, 7.8W, CRI 80+, 3000K, 1040lm, IP20, 60Hz, 110-120V

Certifications: CE, UKCA, UL

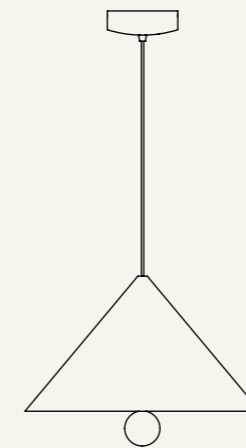
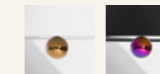

LARGE PENDANT LIGHT

Materials: aluminium, matt grained, steel, plexiglass, fabric cable

Dimensions: Ø19,7 in x H14,8 in

Weight: 5,5 lb

Technical specificities: dimmable, 7.8W, CRI 80+, 3000K, 1040lm, IP20, 60Hz, 110-120V

Certifications: CE, UKCA, UL

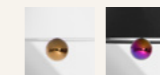

UNSEEN

STUDIOPEPE

When light and sculpture become one ...
Developed in collaboration with the talented Milanese design duo Studiopepe, UNSEEN is a set of modular curved LED-light tubes that seemingly float in space. The collection is a sleek lighting ensemble, proof of astounding technical mastery and profound simplicity. UNSEEN creates a unique visual language with symbol-like curves that sublimate the pureness of light. The graphic lines of the lighting elements have been adapted to a range of wall and ceiling fixtures where each individual piece can be placed vertically or horizontally. While emphasising on a playful and sophisticated design, Petite Friture has succeeded in releasing a collection that arouse emotions with its unique, elegant, and sensitive touch.

Environment: indoor
LED lighting



[Back to summary](#)



UNSEEN

STUDIOPEPE

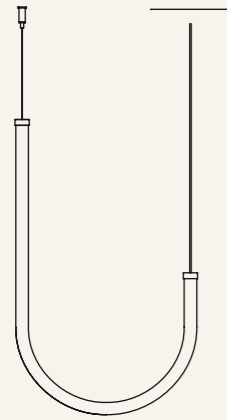

PENDANT LIGHT J

Materials: varnished brass, polycarbonate, mat smooth powder coated steel, transparent plastic
Dimensions: L13,8 in x W1,2 in x H22,8 in
Weight: 3,3 lb
Technical specificities: 12W, CRI 95+, 3000K, 1030lm, IP20, 60Hz, 110-120V
Certifications: CE, UKCA, UL

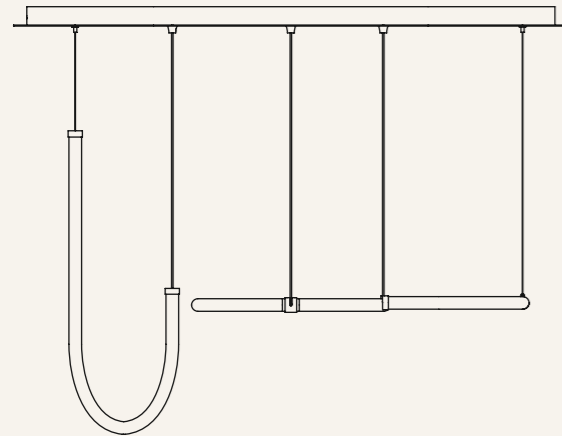

TRIPLE PENDANT SYSTEM

Materials: varnished brass, polycarbonate, mat smooth powder coated steel, transparent plastic
Dimensions: L34,3 in x W13,8 in x H22,8 in
Weight: 33,1 lb
Technical specificities: 28W, CRI 95+, 3000K, 2410lm, IP20, 60Hz, 110-120V
Certifications: CE, UKCA, UL

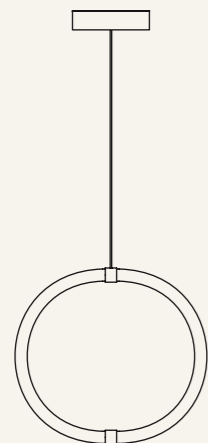

PENDANT LIGHT O

Materials: varnished brass, polycarbonate, mat smooth powder coated steel, transparent plastic
Dimensions: L15 in x W1,2 in x H13,8 in
Weight: 3,1 lb
Technical specificities: 7.6W, CRI 95+, 3000K, 660lm, IP20, 60Hz, 110-120V
Certifications: CE, UKCA, UL

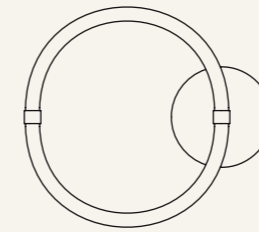

WALL LAMP O

Materials: varnished brass, polycarbonate, mat smooth powder coated steel, transparent plastic
Dimensions: L16,5 in x W2,8 in x H15 in
Weight: 3,1 lb
Technical specificities: 7.6W, CRI 95+, 3000K, 660lm, IP20, 60Hz, 110-120V
Certifications: CE, UKCA, UL

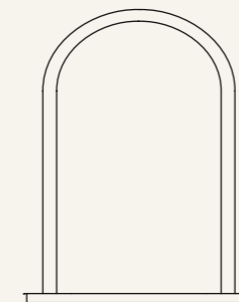

LARGE TABLE LAMP

Materials: varnished brass, polycarbonate, mat smooth powder coated steel, transparent plastic
Dimensions: L15,5 in x H23,6 in x W6,7 in
Weight: 3,3 lb
Technical specificities: 16W, CRI 95+, 2700K, 1650lm, IP20, 60Hz, 110-120V
Certifications: CE, UKCA, UL





02 FURNITURE

SANDOWS

RENÉ HERBST

The Sandows furniture collection is a set of indoor seating designed by René Herbst. Petite Friture pays tribute to this pioneer of industrial furniture by reissuing the Chair N°212, the Armchair, and the Daybed N°114, bringing these pieces back to the heart of contemporary interiors. The clean, graphic lines of the frames, combined with the sandows that ensure ergonomic comfort, give the Sandows collection a unique originality. The tubular frames are made of chromed steel manufactured in Italy, and the sandows are made of rubber covered in fabric.

Environment: indoor



SANDOWS

RENÉ HERBST

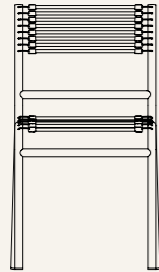

CHAIR N°212

Materials: chromed steel ; rubber ; polyester
Dimensions: L19,5 in x W18,5 in x H32,7 in x Hseat 18,3 in
Weight: 15,4 lb

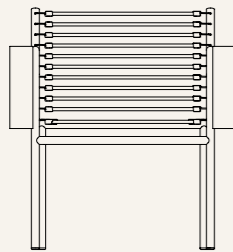

ARMCHAIR WITH ARMRESTS

Materials: chromed steel ; rubber ; polyester ; birch with laquered oak outer side
Dimensions: L22,2 in x W28,0 in x H29,7 in x Hseat 15,9 in
Harmrest 25,2 in
Weight: 26,5 lb

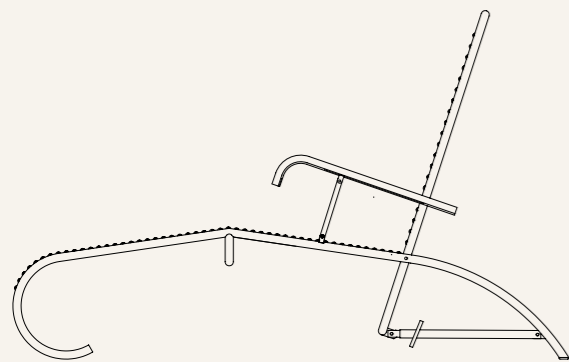

DAYBED N°114

Materials: chromed steel ; rubber ; polyester ; birch with laquered oak outer side, leather
Dimensions: L66,9 in x W25,6 in x H41,9 in x Hseat 15,7 in
Harmrest 24,4 in
Weight: 55,1 lb



ECLIPSE

GARNIER PINGREE

The Eclipse furniture collection offers sculptural seating designed by the duo Garnier Pingree, Marie Garnier and Asa Pingree. This versatile indoor and outdoor collection includes a daybed, a lounge chair, a bench, and an ottoman. The swooping silhouettes are as much about minimal living as they are about movement.

The collection plays with simple shapes - half cylinders and cradles, and radiuses - infusing each piece with graceful, unexpected curves. It combines forms with high-spec material to create a sense of play, balanced with a simplicity of line.

Environment: indoor & outdoor



ECLIPSE

GARNIER PINGREE

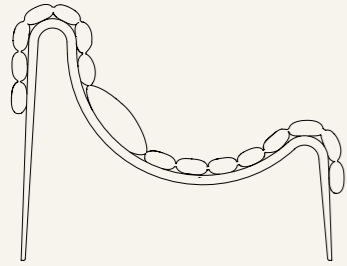

LOUNGE

Materials: aluminium, matte grained epoxy paint, anti uv coating for outdoor use

Dimensions: L34,1 in x 29,1 in x H26,6 in

Weight: 56,2 lb

Certifications: EN 581-1 & EN 581-2 Contract Use

[Click here to see the 23 colours](#)

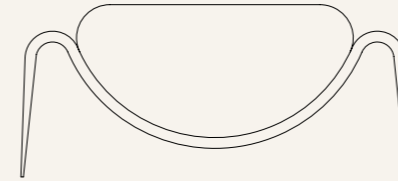

OTTOMAN

Materials: aluminium, matte grained epoxy paint, anti uv coating for outdoor use

Dimensions: L37,4 in x W35,4 in x H13,8 in

Weight: 58,4 lb

Certifications: EN 581-1 & EN 581-2 Contract Use

[Click here to see the 23 colours](#)

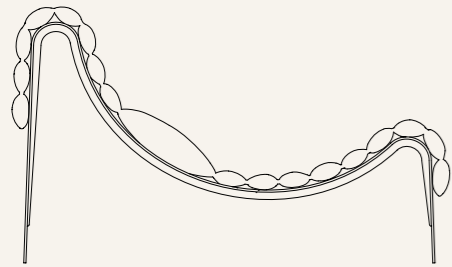

DAYBED

Materials: aluminium, matte grained epoxy paint, anti uv coating for outdoor use

Dimensions: L44,1 in x W31,9 in x H26,0 in

Weight: 66,4 lb

Certifications: EN 581-1 & EN 581-2 Contract Use

[Click here to see the 23 colours](#)

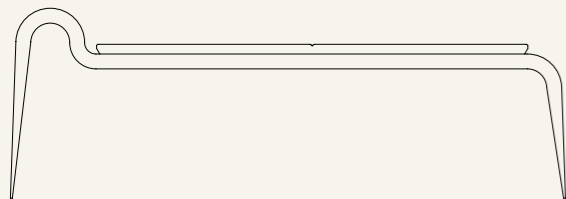

BENCH

Materials: aluminium, matte grained epoxy paint, anti uv coating for outdoor use

Dimensions: L66,9 in x W20,9 in x H23,2 in

Weight: 57,3 lb

Certifications: EN 581-1 & EN 581-2 Contract Use

[Click here to see the 23 colours](#)

FROMME

TOM CHUNG

In designing the emblematic FROMME collection, Tom Chung was driven by a clear desire: harness the technical properties and sleek, streamlined shape of a racing bike as inspiration for an ultra-comfortable seat. The key to his success is found in the use of shock absorbers placed under the seat plate.

Environment: outdoor & indoor



FROMME

TOM CHUNG

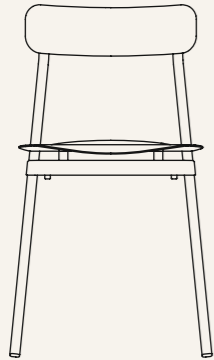

CHAIR

Materials: aluminium, matte grained anti UV powder coating
Dimensions: L18,5 in x W17,7 in x H30,7 in x Hseat 18,1 in
Weight: 8,4 lb
Certifications: EN 581-1 & EN 581-2 Contract Use
[Click here to see the 23 colours](#)

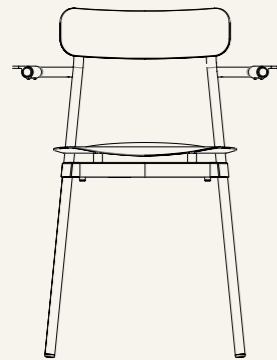

BRIDGE

Materials: aluminium, matte grained anti UV powder coating
Dimensions: L17,9 in x W23,4 in x H30,7 in x Hseat 18,1 in
Weight: 9,9 lb
Certifications: EN 581-1 & EN 581-2 Contract Use
[Click here to see the 23 colours](#)

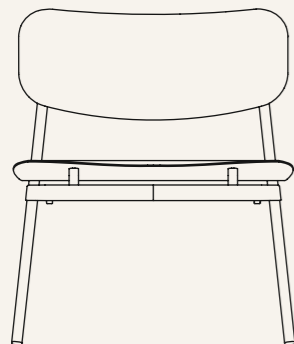

LOUNGE CHAIR

Materials: aluminium, matte grained anti UV powder coating
Dimensions: L24 in x W22,8 in x H28 in x Hseat 15,7 in
Weight: 13 lb
Certifications: EN 581-1 & EN 581-2 Contract Use
[Click here to see the 23 colours](#)

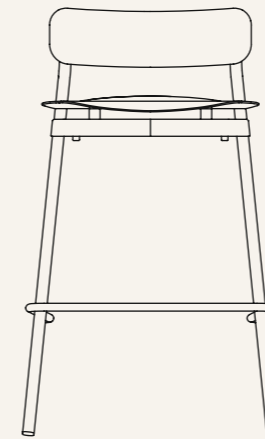

BAR STOOL H65

Materials: aluminium, matte grained anti UV powder coating
Dimensions: L19,3 in x W19,3 in x H31,9 in x Hseat 25,6 in
Weight: 9 lb
Certifications: EN 581-1 & EN 581-2 Contract Use
[Click here to see the 23 colours](#)

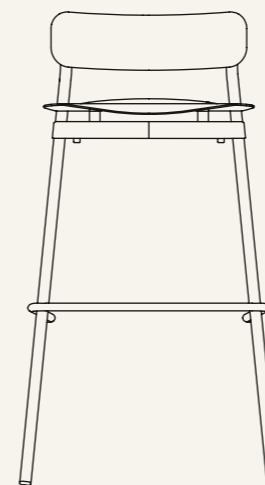

BAR STOOL H75

Materials: aluminium, matte grained anti UV powder coating
Dimensions: L20,1 in x W20,1 in x H36,2 in x Hseat 29,5 in
Weight: 9,9 lb
Certifications: EN 581-1 & EN 581-2 Contract Use
[Click here to see the 23 colours](#)

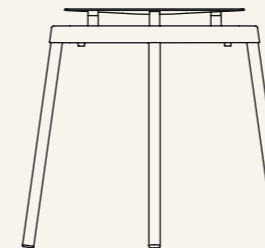

STOOL

Materials: aluminium, matte grained anti UV powder coating
Dimensions: L15 in x W15 in x H17,7 in
Weight: 5,7 lb
Certifications: EN 581-1 & EN 581-2 Contract Use
[Click here to see the 23 colours](#)

FROMME

TOM CHUNG

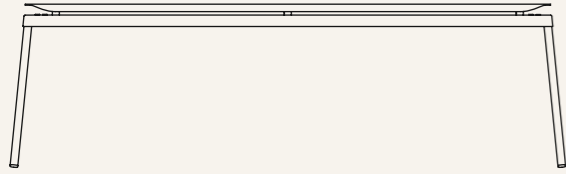

BENCH

Materials: aluminium, matte grained anti UV powder coating

Dimensions: L62,6 in x W16,9 in x H18,5 in

Weight: 20,5 lb

Certifications: EN 581-1 & EN 581-2 Contract Use

[Click here to see the 23 colours](#)

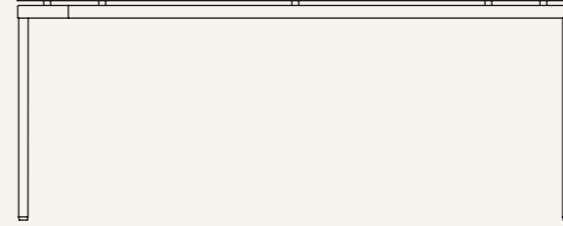

RECTANGLE DINING TABLE

Materials: aluminium, matte grained anti UV powder coating

Dimensions: L70,9 in x W35,4 in x H28,7 in

Weight: 82,7 lb

Certifications: EN 581-1 & EN 581-2 Contract Use

[Click here to see the 23 colours](#)

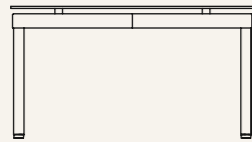

SQUARE COFFEE TABLE

Materials: aluminium, matte grained anti UV powder coating

Dimensions: L27,6 in x W27,6 in x H13,8 in

Weight: 26,5 lb

Certifications: EN 581-1 & EN 581-2 Contract Use

[Click here to see the 23 colours](#)

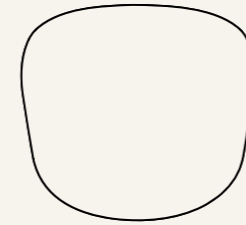

CUSHION

Materials: 100% solution dyed acrylic, high resilience foam

Dimensions: L14,8 in x W14 in x H1,4 in

Weight: 0,4 lb

Fire certifications for the fabric : EN1021-1 cigarette, BS 5852-1 (S4), CA TB 117

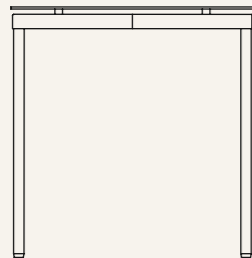
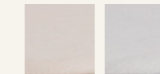

SQUARE DINING TABLE

Materials: aluminium, matte grained anti UV powder coating

Dimensions: L27,6 in x W27,6 in x H28,7 in

Weight: 32 lb

Certifications: EN 581-1 & EN 581-2 Contract Use

[Click here to see the 23 colours](#)



FROMME
TOM CHUNG

23 colours

FROMME WOOD

TOM CHUNG

Building on the success of the original aluminium collection, the Fromme family made by Tom Chung is growing with a much-awaited wooden version that boasts far more opportunities for indoor use. The combined warmth of wood, fabric and leather now features on the Fromme chair's minimalist, streamlined design.

Environment: indoor



FROMME WOOD

TOM CHUNG

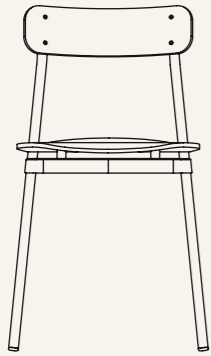

CHAIR

Materials: aluminium, matte grained anti UV powder coating, wood
Dimensions: L18,5 in x W17,7 in x H30,7 in x Hseat 17,7 in
Weight: from 8,0 lb
Certifications: EN16139 Contract use

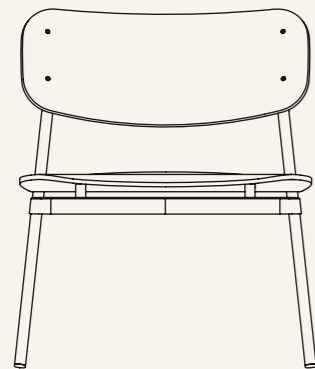
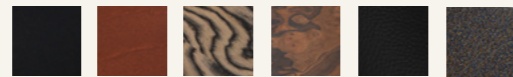

LOUNGE CHAIR

Materials: aluminium, matte grained anti UV powder coating, wood
Dimensions: L24 in x W22,8 in x H28 in x Hseat 15,7 in
Weight: from 11,7 lb
Certifications: EN16139 Contract use

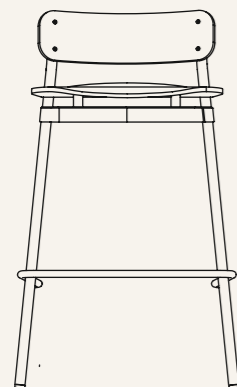
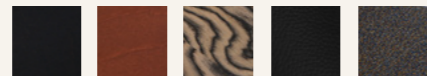

BAR STOOL H65CM

Materials: aluminium, matte grained anti UV powder coating, wood
Dimensions: L19,3 in x W19,3 in x H31,9 in x Hseat 25,6 in
Weight: from 7,9 lb
Certifications: EN16139 Contract use

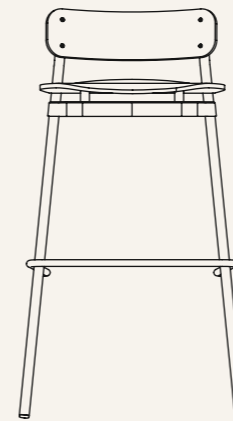
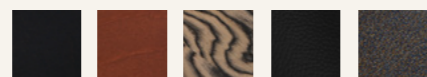

BAR STOOL H75CM

Materials: aluminium, matte grained anti UV powder coating, wood
Dimensions: L20,1 in x W20,1 in x H35,8 in x Hseat 29,5 in
Weight: from 8,8 lb
Certifications: EN16139 Contract use

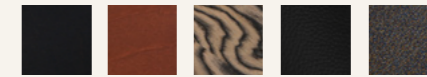

WEEK-END

STUDIO BRICHETZIEGLER

Designed with the French studio BrichetZiegler, the entire WEEK-END collection of outdoor furniture is readily recognisable thanks to its graphic and ergonomic hallmarks: the framed oval shape, the interaction between horizontal and vertical stripe-like slats. The delicate curves blend with the collection's visual and physical lightness in a robust and long-lasting design. Made using aluminium that can resist corrosion, salty air, and UV radiation, the full range is both sustainable and environmentally friendly.

Environment: outdoor & indoor

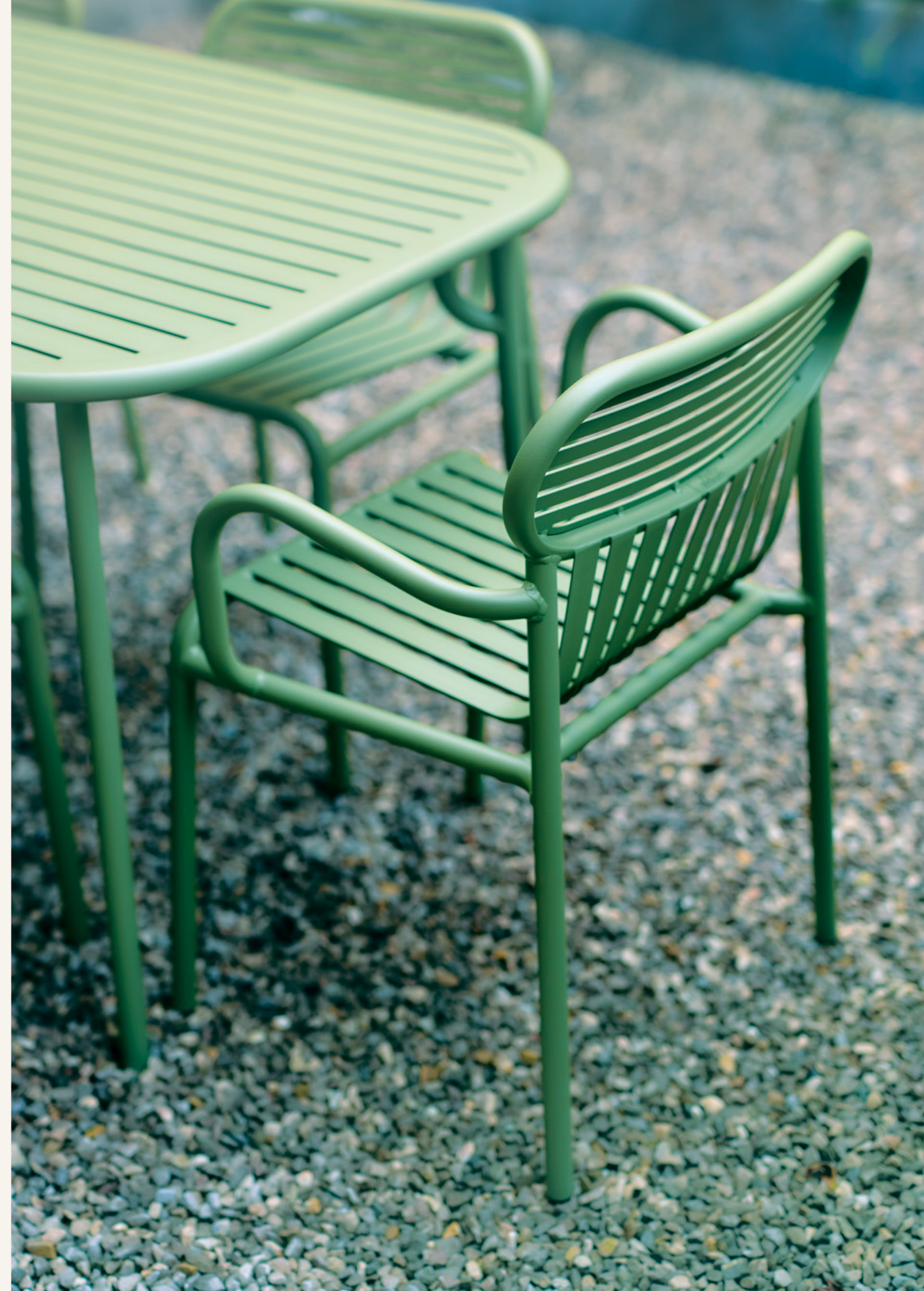

WEEK-END

STUDIO BRICHETZIEGLER

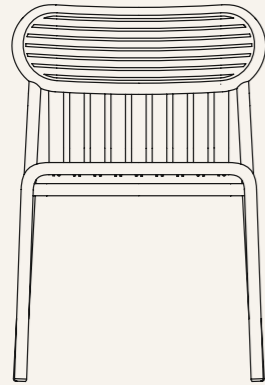

CHAIR

Materials: aluminium, matte grained anti-UV powder coating
Dimensions: L20,5 in x W19,7 in x H30,3 in x Hseat 17,7 in
Weight: 6,6 lb
Certifications: CE, FCC
Quickship: black, white, jade green and glass green
[Click here to see the 23 colours](#)

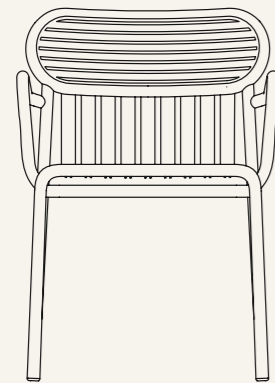

CHAIR WITH ARMRESTS

Materials: aluminium, matte grained anti-UV powder coating
Dimensions: L22,4 in x W19,7 in x H30,3 in x Hseat 17,7 in
Weight: 8,8 lb
Certifications: CE, FCC
Quickship: black, white, jade green and glass green
[Click here to see the 23 colours](#)

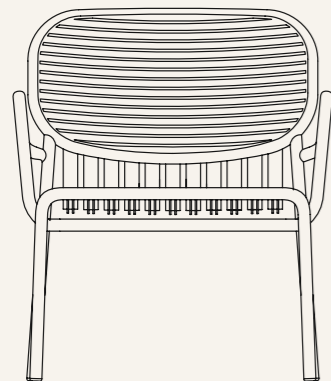

ARMCHAIR

Materials: aluminium, matte grained anti-UV powder coating
Dimensions: L25,2 in x W24,4 in x H30,3 in x Hseat 15,7 in
Weight: 11 lb
Certifications: CE, FCC
[Click here to see the 23 colours](#)

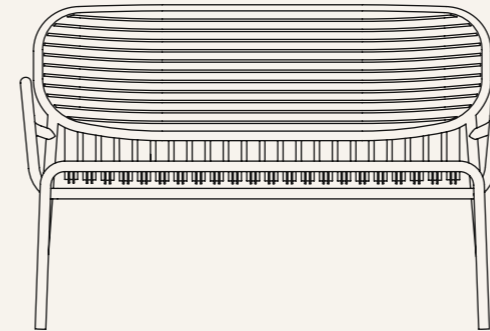

DOUBLE SOFA

Materials: aluminium, matte grained anti-UV powder coating
Dimensions: L44,7 in x W25,2 in x H30,9 in x Hseat 15,7 in
Weight: 22 lb
Certifications: CE, FCC
[Click here to see the 23 colours](#)

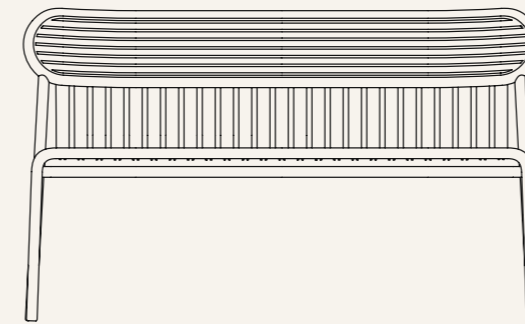

BENCH

Materials: aluminium, matte grained anti-UV powder coating
Dimensions: L47,6 in x W19,3 in x H30,3 in x Hseat 17,7 in
Weight: 19,8 lb
Certifications: CE, FCC
[Click here to see the 23 colours](#)

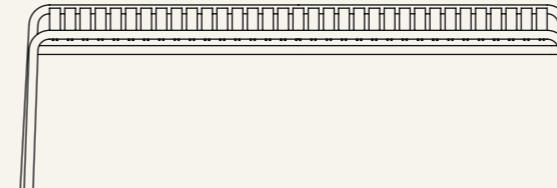

BENCH WITHOUT BACK

Materials: aluminium, matte grained anti-UV powder coating
Dimensions: L61,4 in x W18,9 in x H17,7 in
Weight: 17,6 lb
Certifications: CE, FCC
[Click here to see the 23 colours](#)

WEEK-END

STUDIO BRICHETZIEGLER

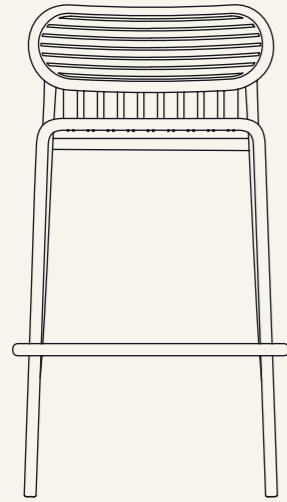

BAR STOOL

Materials: aluminium, matte grained anti-UV powder coating
Dimensions: L21,7 in x W19,3 in x H40,9 in x Hseat 31,5 in
Weight: 8,8 lb
Certifications: EN 581-1 & EN 581-2 Contract Use
Quickship: black, white, jade green and glass green
[Click here to see the 23 colours](#)

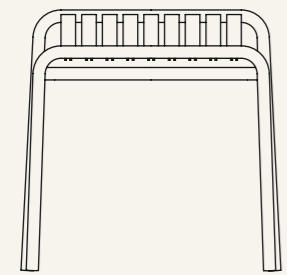

STOOL

Materials: aluminium, matte grained anti-UV powder coating
Dimensions: L21,3 in x W18,9 in x H20,9 in x Hseat 17,7 in
Weight: 6,6 lb
Certifications: EN 581-1 & EN 581-2 Contract Use
[Click here to see the 23 colours](#)



FOOTSTOOL / SIDE TABLE

Materials: aluminium, matte grained anti-UV powder coating
Dimensions: L22,4 in x W16,9 in x H15,4 in
Weight: 5,5 lb
Certifications: EN 581-1 & EN 581-2 Contract Use
[Click here to see the 23 colours](#)

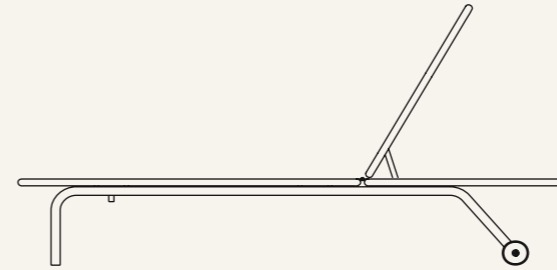

SUNBED

Materials: aluminium, matte grained anti-UV powder coating
Dimensions: L83,9 in x W25,6 in x H13,8 in
Weight: 46,3 lb
Certifications: EN 581-1 & EN 581-2 Contract Use
[Click here to see the 23 colours](#)

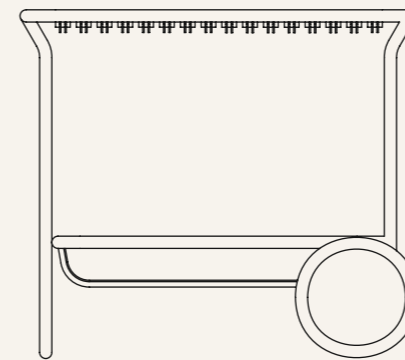

TROLLEY

Materials: aluminium, matte grained anti-UV powder coating
Dimensions: L32,3 in x W18,9 in x H28,7 in
Weight: 17,6 lb
Certifications: EN 581-1 & EN 581-2 Contract Use
[Click here to see the 23 colours](#)



SMALL COFFEE TABLE

Materials: aluminium, matte grained anti-UV powder coating
Dimensions: L23,6 in x W27,2 in x H12,6 in
Weight: 11 lb
Certifications: EN 581-1 & EN 581-2 Contract Use
[Click here to see the 23 colours](#)

WEEK-END

STUDIO BRICHETZIEGLER



LONG COFFEE TABLE

Materials: aluminium, matte grained anti-UV powder coating

Dimensions: L50 in x W20,1 in x H16,1 in

Weight: 15,4 lb

Certifications: EN 581-1 & EN 581-2 Contract Use

[Click here to see the 23 colours](#)

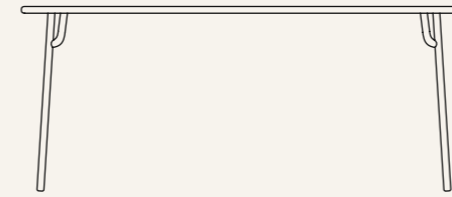

MEDIUM RECTANGLE TABLE - SLATS

Materials: aluminium, matte grained anti-UV powder coating

Dimensions: L70,9 in x W33,5 in x H29,5 in

Weight: 45 lb

Certifications: EN 581-1 & EN 581-2 Contract Use

[Click here to see the 23 colours](#)

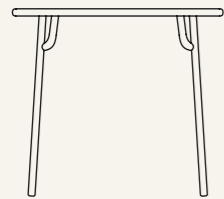

SQUARE TABLE - SLATS

Materials: aluminium, matte grained anti-UV powder coating

Dimensions: L33,5 in x W33,5 in x H29,5 in

Weight: 25,1 lb

Certifications: EN 581-1 & EN 581-2 Contract Use

Quickship: black, white, jade green and glass green

[Click here to see the 23 colours](#)



MEDIUM RECTANGLE TABLE - PLAIN

Materials: aluminium, matte grained anti-UV powder coating

Dimensions: L70,9 in x W33,5 in x H29,5 in

Weight: 51,1 lb

Certifications: EN 581-1 & EN 581-2 Contract Use

[Click here to see the 23 colours](#)

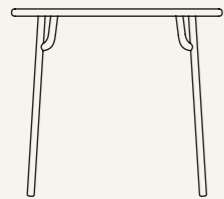

SQUARE TABLE - PLAIN

Materials: aluminium, matte grained anti-UV powder coating

Dimensions: L33,5 in x W33,5 in x H29,5 in

Weight: 29,3 lb

Certifications: EN 581-1 & EN 581-2 Contract Use

[Click here to see the 23 colours](#)

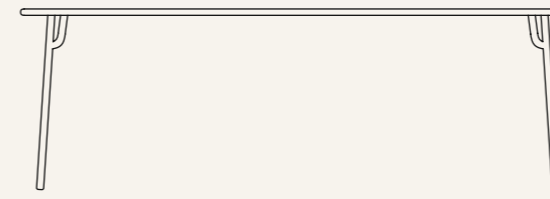

LARGE RECTANGLE TABLE - SLATS

Materials: aluminium, matte grained anti-UV powder coating

Dimensions: L86,6 in x W33,5 in x H29,5 in

Weight: 58,2 lb

Certifications: EN 581-1 & EN 581-2 Contract Use

Quickship: black, white, jade green and glass green

[Click here to see the 23 colours](#)

WEEK-END

STUDIO BRICHETZIEGLER



LARGE RECTANGLE TABLE - PLAIN

Materials: aluminium, matte grained anti-UV powder coating

Dimensions: L86,6 in x W33,5 in x H29,5 in

Weight: 61,1 lb

Certifications: EN 581-1 & EN 581-2 Contract Use

[Click here to see the 23 colours](#)

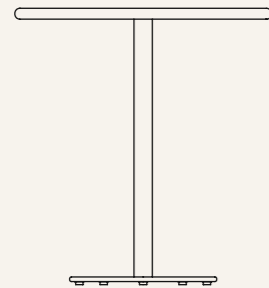

BISTRO TABLE - ROUND

Materials: aluminium, matte grained anti-UV powder coating

Dimensions: Ø27,6 in x H29,5 in

Weight: 22 lb

Certifications: EN 581-1 & EN 581-2 Contract Use

[Click here to see the 23 colours](#)

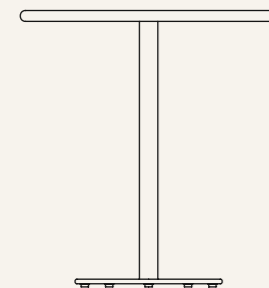

BISTRO TABLE - SQUARE

Materials: aluminium, matte grained anti-UV powder coating

Dimensions: L23,6 in x W23,6 in x H29,5 in

Weight: 24,3 lb

Certifications: EN 581-1 & EN 581-2 Contract Use

[Click here to see the 23 colours](#)

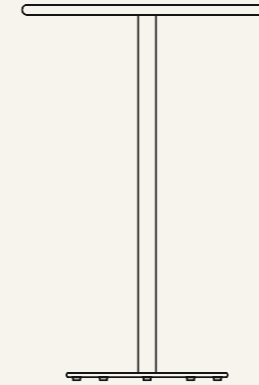

HIGH TABLE - ROUND

Materials: aluminium, matte grained anti-UV powder coating

Dimensions: Ø27,6 in x H41,3 in

Weight: 26,5 lb

Certifications: EN 581-1 & EN 581-2 Contract Use

[Click here to see the 23 colours](#)

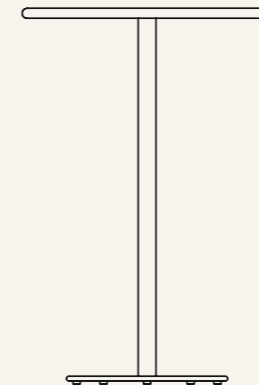

HIGH TABLE - SQUARE

Materials: aluminium, matte grained anti-UV powder coating

Dimensions: L23,6 in x W23,6 in x H41,3 in

Weight: 28,7 lb

Certifications: EN 581-1 & EN 581-2 Contract Use

[Click here to see the 23 colours](#)

WEEK-END

STUDIO BRICHETZIEGLER

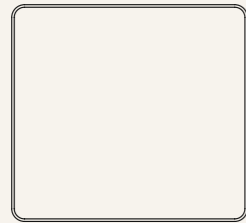

SMALL CUSHION

Materials: 100% solution dyed acrylic, high resilience foam

Dimensions: L15 in x W13,4 in x H1,2 in

Weight: 0,9 lb

Fire certifications for the fabric: EN1021-1 cigarette, BS 5852-1 (S4), CA TB 117

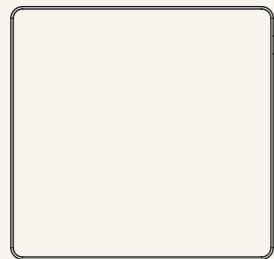
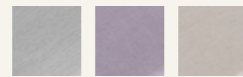

LARGE CUSHION

Materials: 100% solution dyed acrylic, high resilience foam

Dimensions: L17,7 in x W16,9 in x H1,2 in

Weight: 1,1 lb

Fire certifications for the fabric: EN1021-1 cigarette, BS 5852-1 (S4), CA TB 117

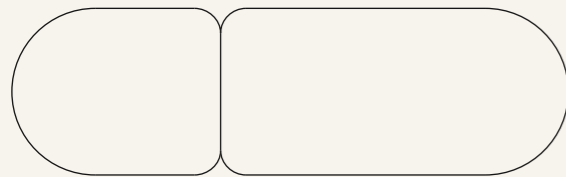
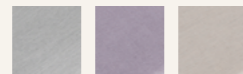

SUNBED CUSHION

Materials: 100% solution dyed acrylic, high resilience foam

Dimensions: L82,7 in x W24,4 in x H2 in

Weight: 6,6 lb

Fire certifications for the fabric: EN1021-1 cigarette, BS 5852-1 (S4), CA TB 117





WEEK-END
STUDIO
BRICHETZIEGLER

23 colours



FRANCIS

*CONSTANCE
GUISSET*

To create the mirror featured on the FRANCIS tables and mirrors, Constance Guisset experimented with colours by adding pigments to water then observing how they spread and bloomed to the surface. Laid flat, the mirror turns whole notion of reflection on its head. Be it illusion or fascination, it is surely surprising.

Environment: indoor



FRANCIS - TABLES

CONSTANCE GUISSET

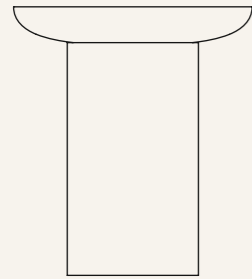

SMALL MIRROR COFFEE TABLE

Materials: mirror, steel with matte grained powder coating
Dimensions: Ø15,7 in x H17,7 in
Weight: 17,6 lb

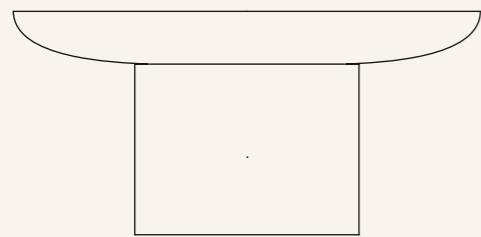

LARGE MIRROR COFFEE TABLE

Materials: mirror, steel with matte grained powder coating
Dimensions: Ø29,5 in x H14,2 in
Weight: 41,9 lb

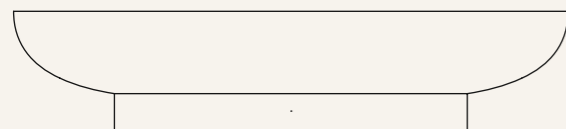

EXTRA LARGE MIRROR COFFEE TABLE

Materials: Mirror, Steel with matte grained powder coating
Dimensions: Ø43,3 in x H9,4 in
Weight: 99,2 lb

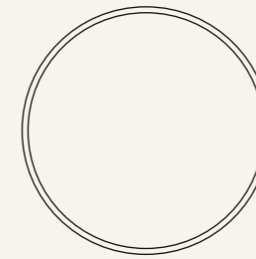

SMALL MIRROR

Materials: mirror, steel with matte grained powder coating
Dimensions: Ø17,7 in x D2 in
Weight: 7,7 lb

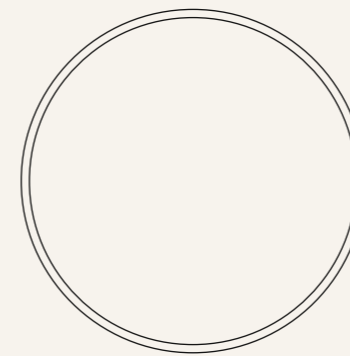
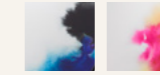

LARGE MIRROR

Materials: mirror, steel with matte grained powder coating
Dimensions: Ø23,6 in x D2 in
Weight: 14,1 lb

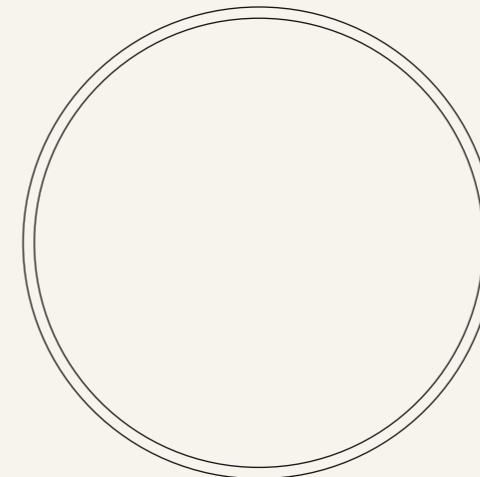
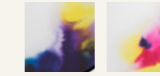

EXTRA LARGE MIRROR

Materials: mirror, steel with matte grained powder coating
Dimensions: Ø43,3 in x D2,2 in
Weight: 50,7 lb

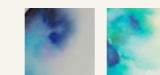

WANDER

AC/AL

The WANDER mirrors by the design duo AC/AL were born from a design practice not bound by constraints. Initially made as paintings and collages, the associations of colours and shapes soon evolved into a collection of two-tone mirrors, to be understood as a collection of pictorial and graphic paintings.

Environment: indoor

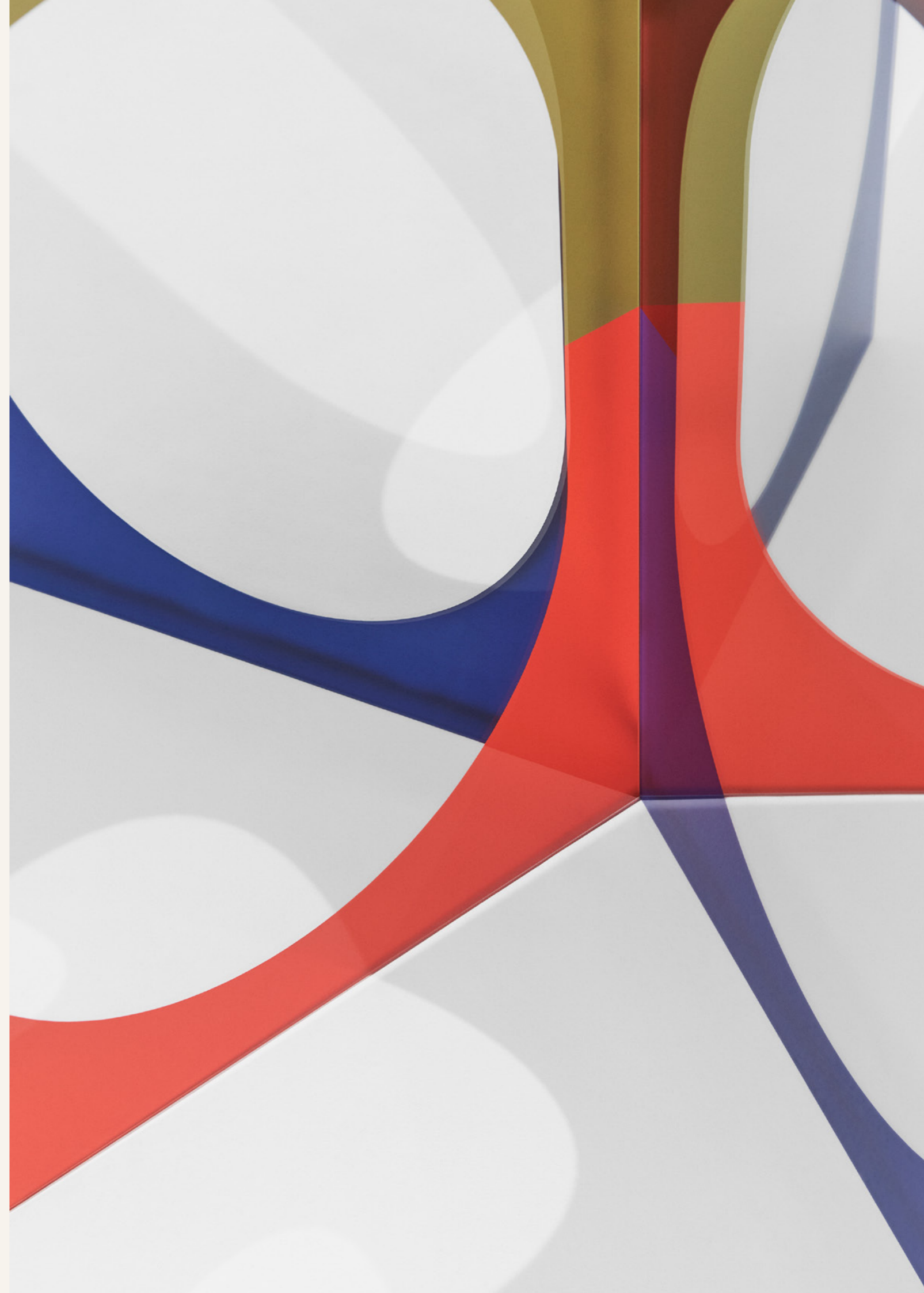

WANDER

AC/AL

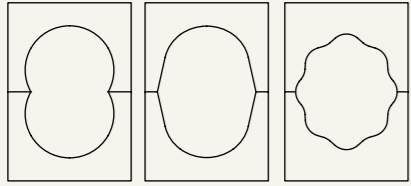

SMALL MIRROR

Materials: glass, steel

Dimensions: L15,7 in x W0,8 in x H21,7 in

Weight: 6,6 lb

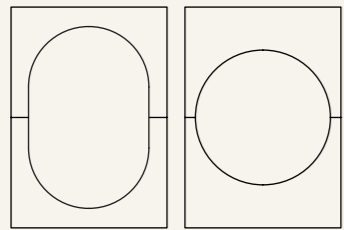

MEDIUM MIRROR

Materials: glass, steel

Dimensions: L26,4 in x W0,8 in x H35,4 in

Weight: 19,8 lb

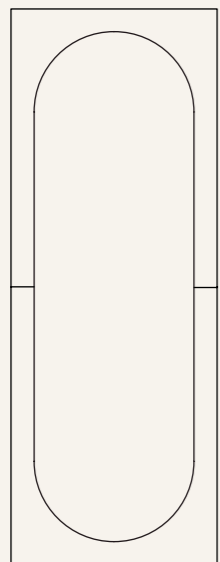

LARGE MIRROR

Materials: glass, steel

Dimensions: L26,4 in x W0,8 in x H69,3 in

Weight: 39,7 lb

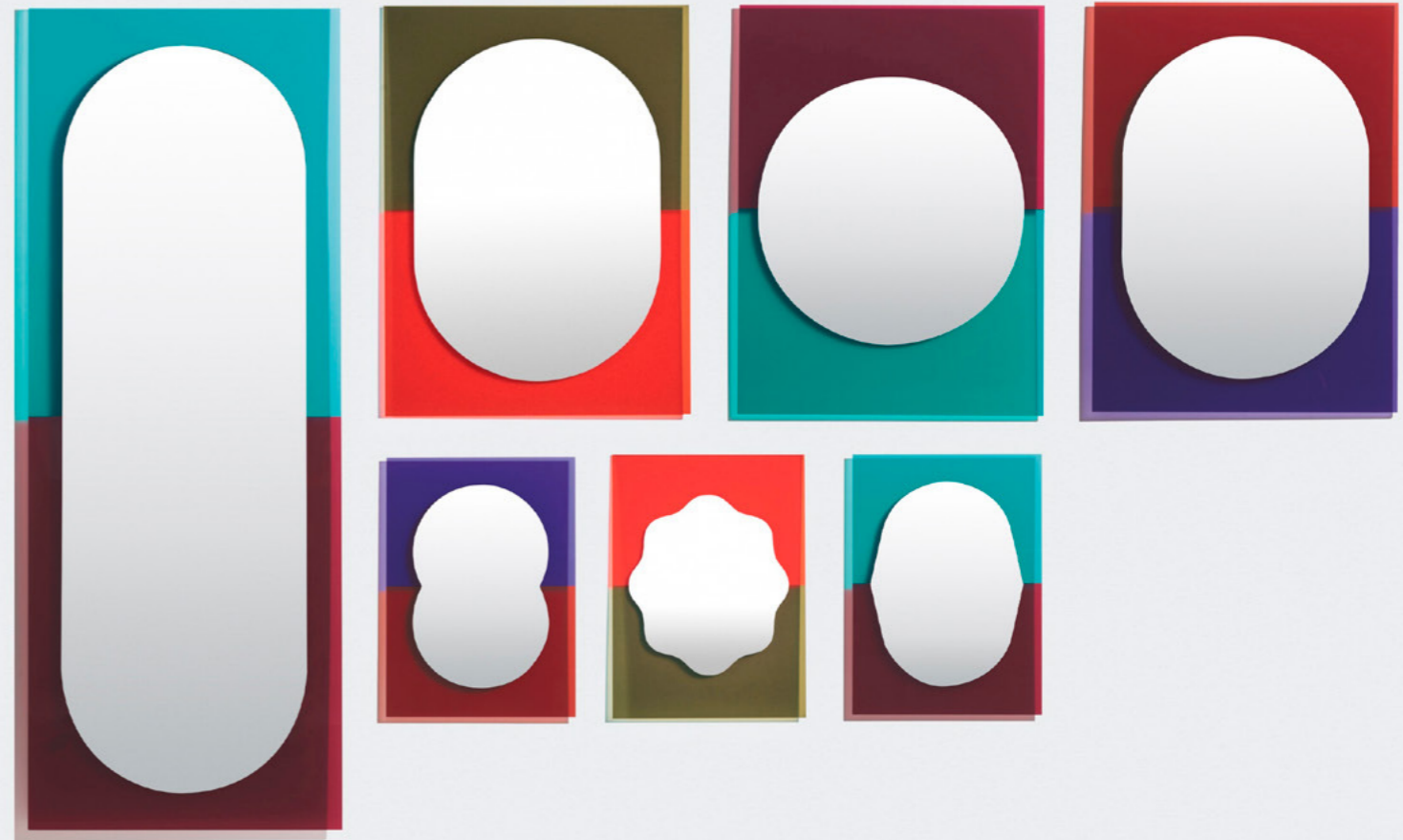



03 UPHOLSTERY

LILY

FÄRG&BLANCHE

Pushing the boundaries of manufacturing is part of the artistic process at Färg&Blanche, the design duo who created the LILY collection. The craftsmanship of their designs, such as seams and welding joint, is always deliberately visible and even elevated. On the LILY upholstered seat collection, the seams are proudly evident, as is the seat's original inspiration: a cushion!

Environment: indoor



LILY

FARG&BLANCHE

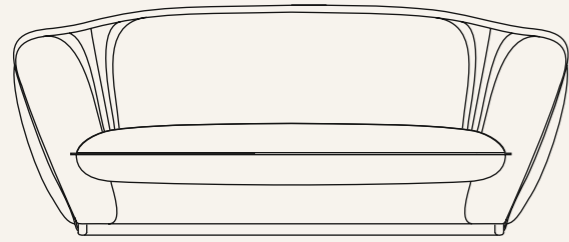

2 SEATER SOFA

Materials: steel, polyurethane foam, elastic bands, polyester fabric

Dimensions: L65 in x W29,5 in x H33,1 in x Hseat 17,7 in

Weight: 130,1 lb

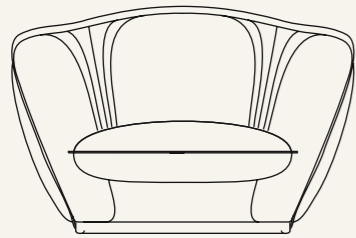

ARMCHAIR

Materials: steel, polyurethane foam, elastic bands, polyester fabric

Dimensions: L33,5 in x W29,5 in x H33,1 in x Hseat 17,7 in

Weight: 86 lb



HOFF

MORTEN & JONAS

Designed by the Morten & Jonas studio, the HOFF collection is designed to be a playful game of building blocks where the upholstered pieces are linked together by brightly coloured legs. The very thin steel legs contrast with the generous lines of the seats.

Environment: indoor



HOFF

MORTEN & JONAS

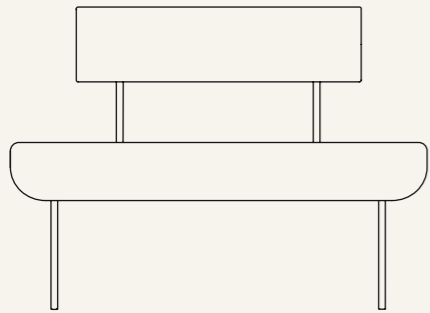

LARGE ARMCHAIR

Materials: steel, matte smooth powder coating, polyurethane foam, fabric

Dimensions: L39,2 in x W26,8 in x H28,5 in x Hseat 15,7 in

Weight: 39,7 lb

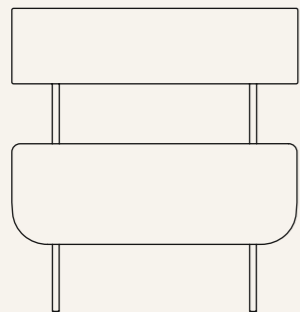

MEDIUM ARMCHAIR

Materials: steel, matte smooth powder coating, polyurethane foam, fabric

Dimensions: L26,8 in x W26,8 in x H28,5 in x Hseat 15,7 in

Weight: 37,5 lb

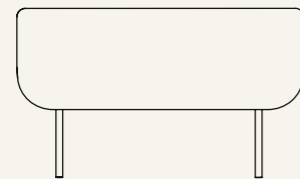

MEDIUM STOOL

Materials: steel, matte smooth powder coating, polyurethane foam, fabric

Dimensions: L26,8 in x W26,8 in x H15,7 in

Weight: 33,1 lb

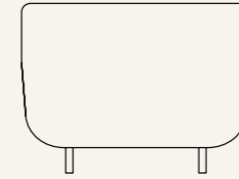

SMALL STOOL

Materials: steel, matte smooth powder coating, polyurethane foam, fabric

Dimensions: L19,7 in x W26,8 in x H15,7 in

Weight: 30,9 lb

UPHOLSTERY

MADE TO ORDER

Fabrics of Lily, Hoff and Eclipse collections can be customized from the following fabric selection in any colour - they are made to order.

The fabrics we propose are compatible with the shape of all our upholstered products.

	LILY	HOFF	ECLIPSE
CATEGORY 1			
Bliss - Aura*	x	x	●
Kvadrat - Reflect	○	○	●
Kvadrat - Haku	●	●	○
Kvadrat - Patio	x	x	○
CATEGORY 2			
Kvadrat - Hero	●	●	●
Kvadrat - Hero Heather	●	●	●
Kvadrat - Jaali	●	●	●
Kvadrat - Steelcut	●	●	●
Kvadrat - Steelcut Trio	●	●	●
Kvadrat - Steelcut Quartet	●	●	●
Kvadrat - Raas	●	●	●
CATEGORY 3			
Kvadrat - Asator	●	●	●
Kvadrat - Acca Stripe	●	●	●
Kvadrat - Beda	●	●	○
Dedar - Strange loves*	x	x	○
CATEGORY 4			
Kvadrat - Cifrado	●	●	●
Kvadrat - Vidar 4	●	●	●
Kvadrat - Vanir	●	●	●
CATEGORY 5			
Kvadrat - Phlox	●	●	●
Kvadrat - Atom	●	●	○

● compatible fabric ○ retail proposed fabric * outdoor

CUSTOMER-SPECIFIC FABRIC CUSTOMIZATION UPON REQUEST (COM)

Fabric of the Lily, Hoff and Eclipse collections can also be customized with given fabric. This fabric must be compatible with the product shapes.





DONUT

PIA CHEVALIER

Pia Chevalier was inspired by the world of pastry as she concocted her DONUT collection. The ceramic mugs look almost edible with icing-like enamel and doughnut-shaped handles. The DONUT's mouthwatering design whets the appetite with a delicious range of colours and a delightful choice of sizes: Espresso, Mug, and XXL.

Environment: indoor



[Back to summary](#)



DONUT

PIA CHEVALIER

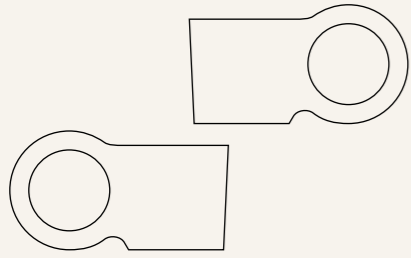

SET OF 2 ESPRESSO CUPS

Materials: earthenware
Dimensions: L4,7 in x W2,4 in x H2,2 in
Weight: 0,7 lb

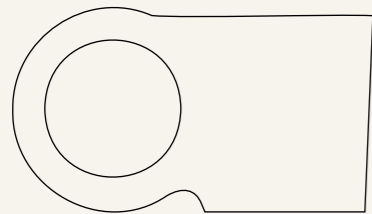
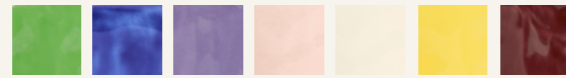

MEDIUM MUG

Materials: earthenware
Dimensions: L6,7 in x W3,1 in x H3,5 in
Weight: 0,7 lb

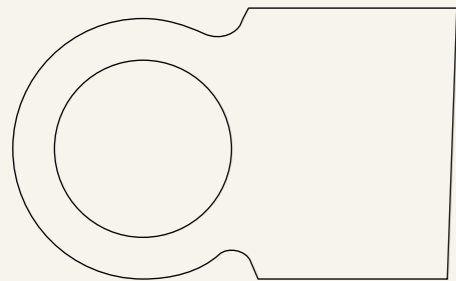
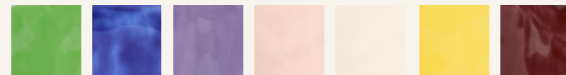

LARGE MUG

Materials: earthenware
Dimensions: L8,3 in x W3,5 in x H4,7 in
Weight: 1,1 lb

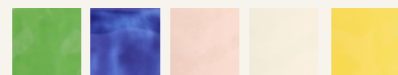

BUBBLE

*VAULOT
& DYÈVRE*

The BUBBLE hook collection, created by the design duo Vaulot & Dyèvre, draws on the unique shapes of soap bubbles in a creative new take on the traditional coat hook. Natural light passing through the hooks onto the wall behind highlights the duality of the material as both transparent and intensely coloured.

Environment: indoor



BUBBLE

VAULOT
& DYÈVRE

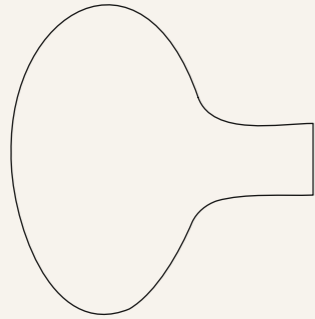

LARGE HOOK

Materials: hook in blown glass, fixing system in steel

Dimensions: Ø5,1 in x D5,9 in

Weight: 1,8 lb

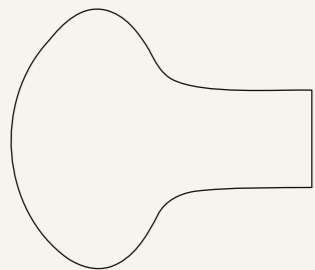

SMALL HOOK

Materials: hook in blown glass, fixing system in steel

Dimensions: Ø3,7 in x D3 in

Weight: 0,6 lb



SHADES OF TIME

CAROLE BAIJINGS

Infinitely more sophisticated than a play of two-tone lines, Carole Baijings completely reinvents the iconic French stripe with a shifting colour palette. In her range of wallpaper and panoramics, each vertical stripe is a changing colour; yet seen as a whole, the stripes reveal a moving landscape.

Environment: indoor

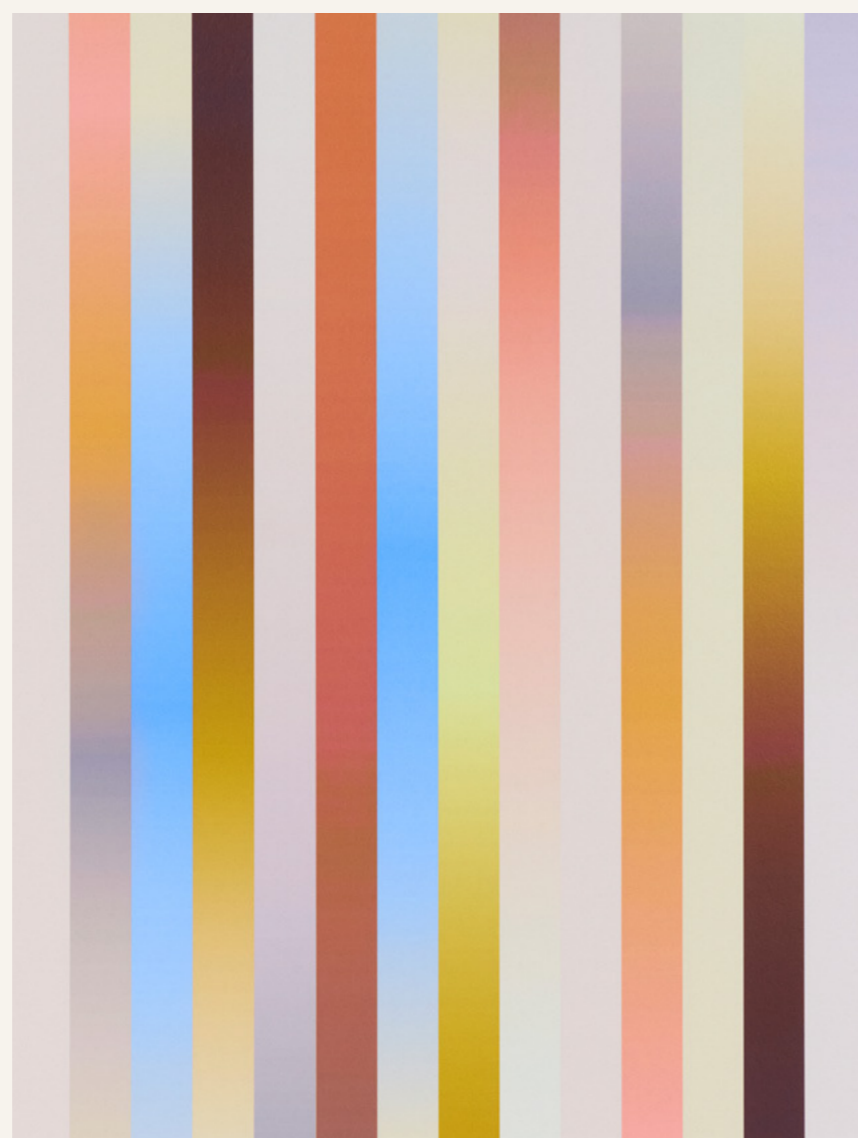

SHADES OF TIME

CAROLE BAIJINGS

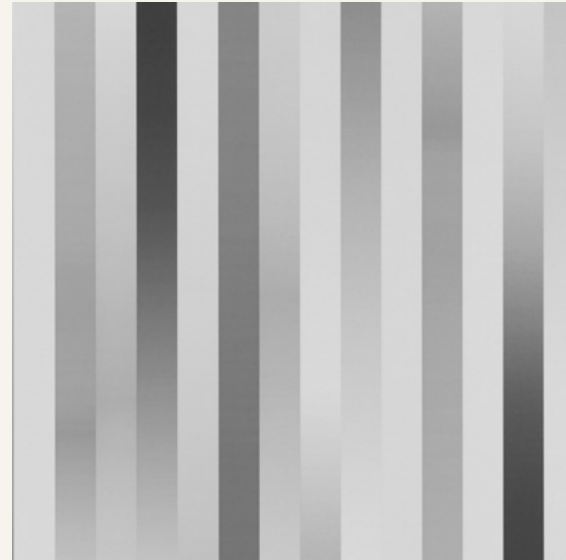

LARGE STRIPES

Materials: non-woven wallpaper -
Available in a Contract grade wallpaper without PVC (510\$)
Contact us for more information

Dimensions: L394 in x W19,7 in

Weight: 3,9 lb

Certification: C-s1-d0

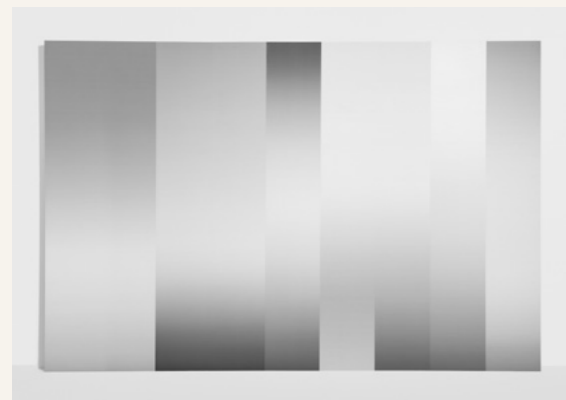
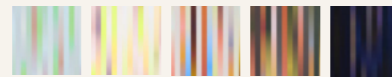

PANORAMA

Materials: non-woven wallpaper -
Available in a Contract grade wallpaper without PVC (339€)
Contact us for more information

Dimensions: L394 in x W19,7 in

Weight: 3,9 lb

Certification: C-s1-d0

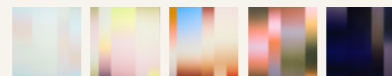

COURTYARD

LES CRAFTIES

A group of young curious minds, The Crafties give a modern twist to ancestral craftsmanship, where traditional techniques meet whimsically contemporary patterns. The designers infused historically rich patterns into their COURTYARD wallpaper collection for Petite Friture.

Environment: indoor

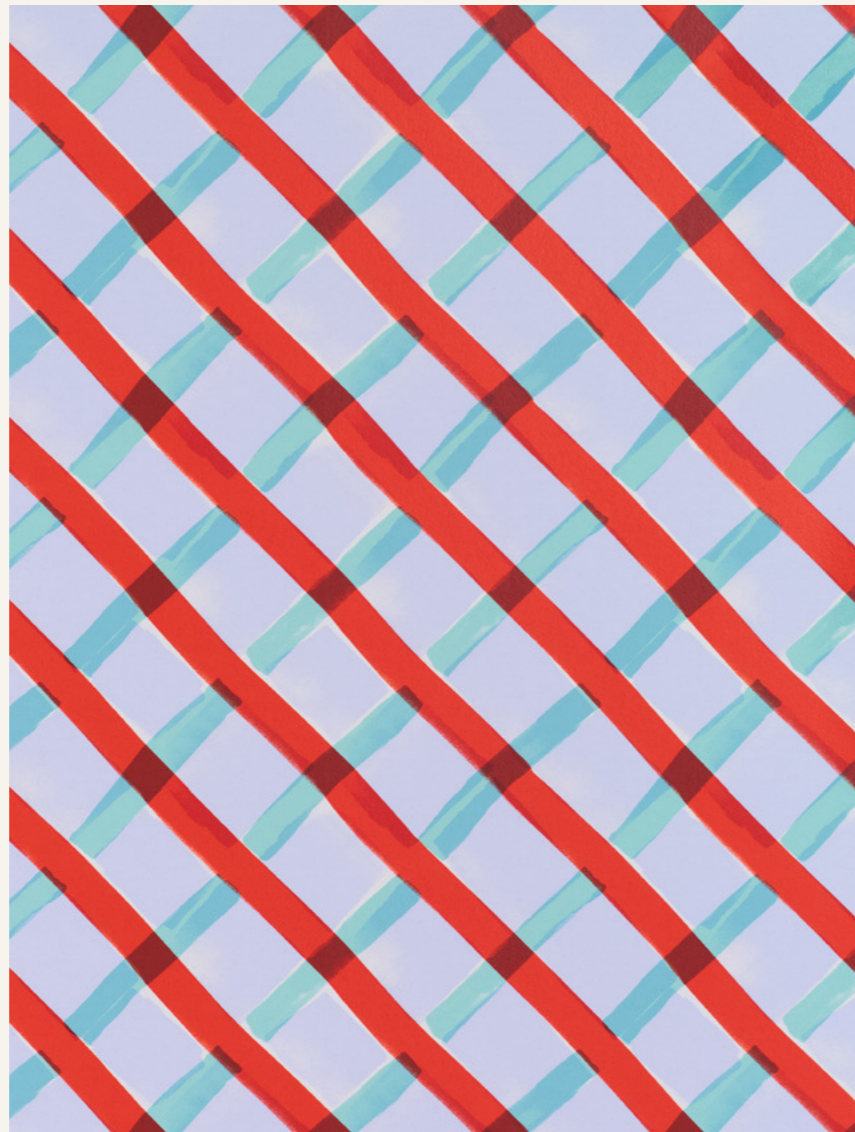

COURTYARD

LES CRAFTIES

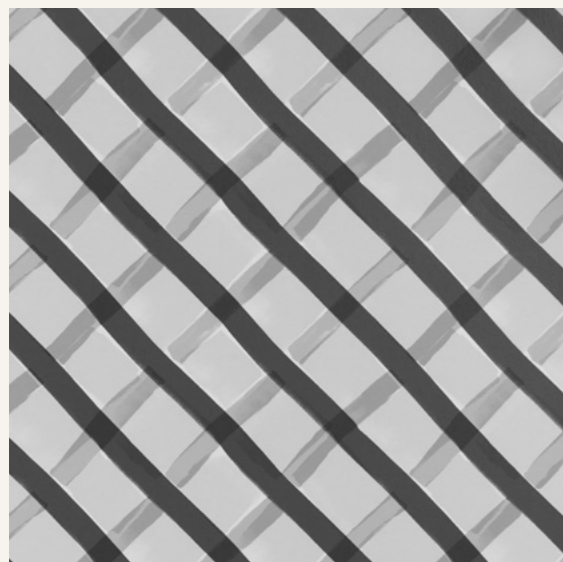

CROISILLON

Materials: non-woven wallpaper - Available in a Contract grade wallpaper without PVC (510\$)
Contact us for more information

Dimensions: L394 in x W19,7 in

Weight: 3,9 lb

Certifications: C-s1-d0

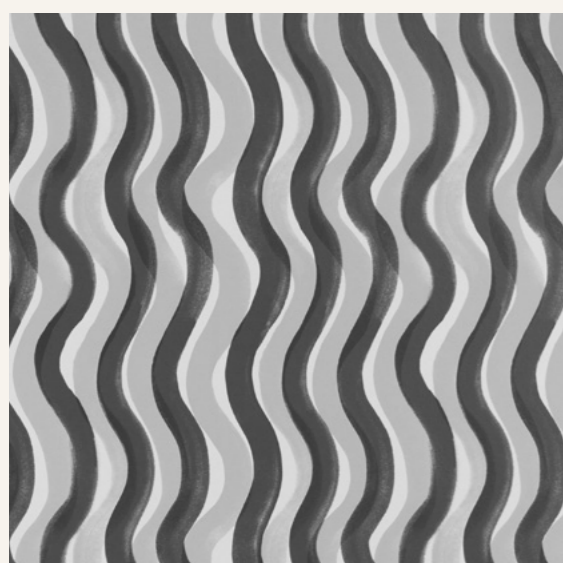
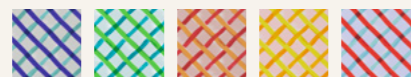

GAUFRETTE

Materials: non-woven wallpaper - Available in a Contract grade wallpaper without PVC (510\$)
Contact us for more information

Dimensions: L394 in x W19,7 in

Weight: 3,9 lb

Certifications: C-s1-d0

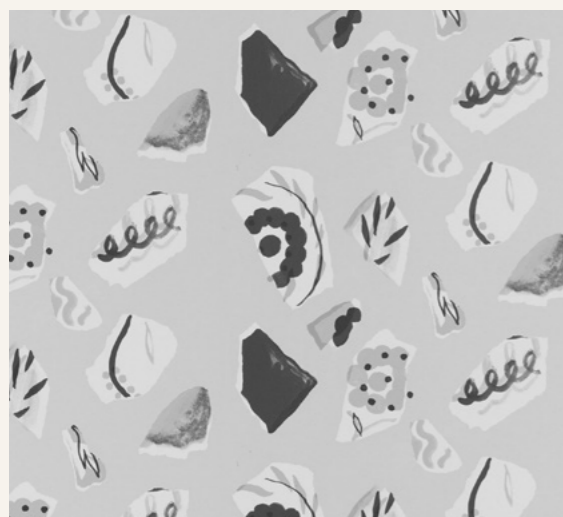
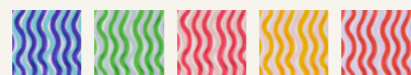

MOSAÏQUE

Materials: non-woven wallpaper - Available in a Contract grade wallpaper without PVC (339€)
Contact us for more information

Dimensions: L394 in x W19,7 in

Weight: 3,9 lb

Certifications: C-s1-d0

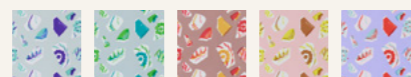

Petite Friture

Showroom:
45ter rue de la Révolution,
93100, Montreuil
110

[Asset library link](#)

[Back to summary](#)