



Servomuto Collection

SERVOMUTO è un brand di lighting design con sede a Milano.

Dal 2010 persegue un obiettivo ambizioso: rivisitare un oggetto classico come il paralume con un twist contemporaneo e spiccatamente sofisticato.

Lo studio e la ricerca dietro a ogni creazione sono visibili nei continui rimandi stilistici al mondo dell'architettura e a luoghi lontani.

Proprio come in un atelier di alta sartoria, le lampade prendono vita: nobili materiali e pregiati tessuti vengono sapientemente accostati, sperimentando con colori e texture inusuali. Le scelte stilistiche vengono sublimate dalla lavorazione orgogliosamente artigianale. Dalle strutture in metallo curvato, passando per i plissé, fino alle finiture applicate da sarte esperte: il "fatto a mano" è più che mai autentico.

La produzione "Haute Couture" contrasta deliberatamente con la meccanizzazione dell'industria manifatturiera di larga scala.

Lo sguardo giocoso e sognante con cui da sempre SERVOMUTO guarda la luce sposa il rigore sartoriale. Il risultato è molto più di una lampada: un oggetto dal design unico, dalla forte capacità evocativa e dallo stile squisitamente italiano.

SERVOMUTO is a lighting design brand based in Milan.

Since 2010 it has been pursuing an ambitious goal: to revisit a classic object such as the lampshade with a contemporary and distinctly sophisticated twist.

The study and research behind each creation are visible in the continuous stylistic references to the world of architecture and distant places.

Just like in a haute couture atelier, the lamps come to life: prestigious materials and fine fabrics are skilfully combined, experimenting with unusual colors and textures. The stylistic choices are proudly enhanced by the craftsmanship. From the curved metal structures, the pleats, to the finishes applied by expert seamstresses: "handmade" is more authentic than ever.

The "haute couture" production deliberately contrasts with the mechanization of large-scale manufacturing processes.

The playful and dreamy gaze with which SERVOMUTO has always looked at light embraces the sartorial precision. The result is much more than a lamp: an object with a unique design, a strong evocative capacity together with exquisite Italian style.

Servomuto

Collection

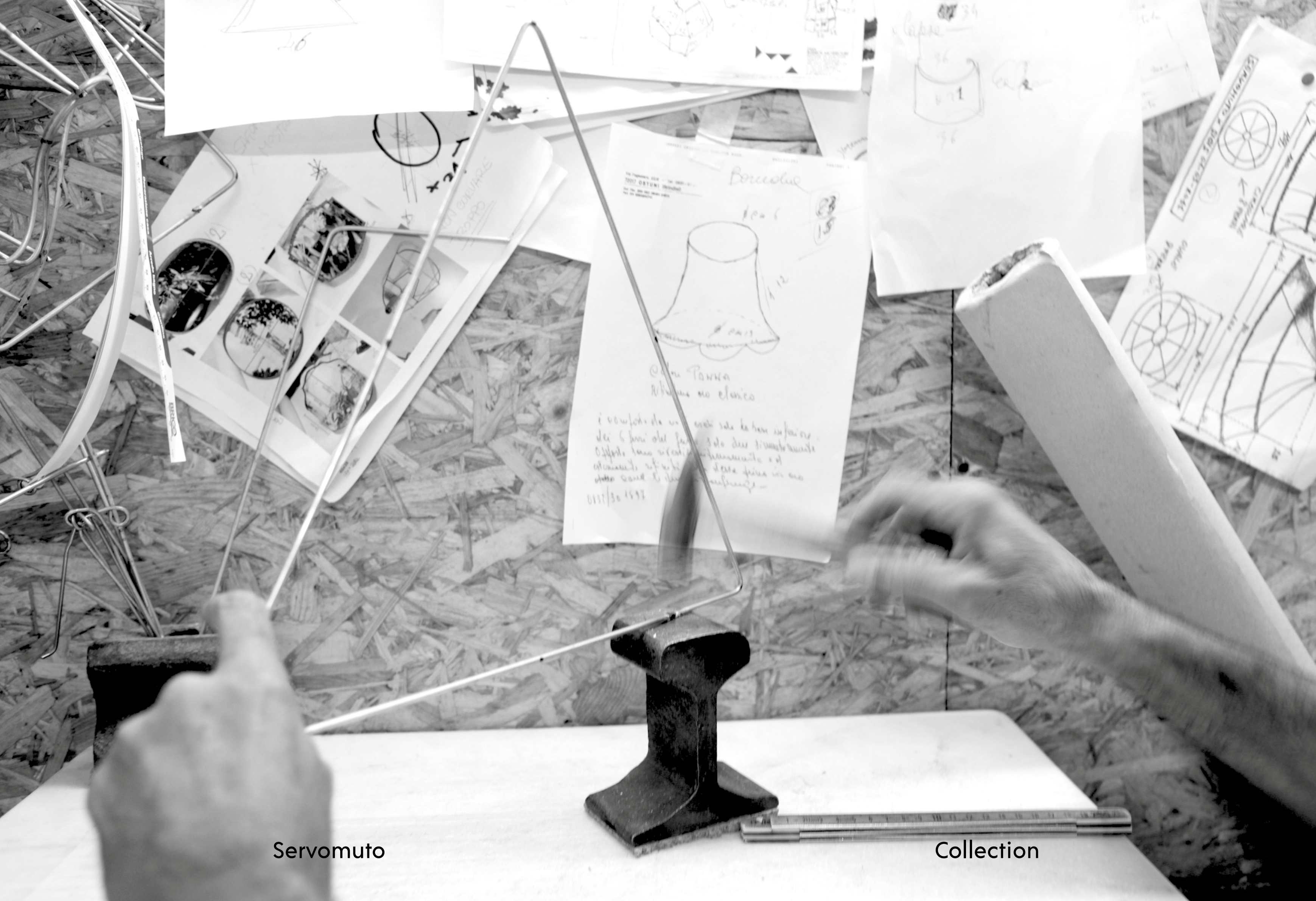

Servomuto

Collection



Servomuto

Collection

PENDANT

Aperitivo - 12

Circus Chandelier - 20

Easy Roof - 26

Fez - 32

Giardino Pendant - 36

Materia - 42

Meringa - 50

Otto Pendant - 58

Palazzi - 66

Venus - 72

WALL

Bikini - 82

Birds & Butterflies - 90

Chalk - 102

Chez Joséphine - 108

Easy Wall - 116

Été - 124

Flag Wall - 128

Guinea Wall - 134

Portofino - 140

FLOOR

Easy Floor - 148

Flag Floor - 154

Giardino Floor - 164

Haute Couture - 170

TABLE

Huf - 180

Cement - 188

Easy Table - 196

Otto Table - 202

SPECIAL EDITION

Alghero - 212

Ambarabà - 218

Cime Tempestose - 224

I wanna be your dog - 230

Satisfaction - 236

PENDANT

Aperitivo

Ispirata alle atmosfere dei bar italiani degli anni Trenta, nei quali si beveva Campari circondati dalle grafiche di Depero, la lampada Aperitivo è abbellita dalla pregiata stoffa Hermès con stampa geometrica "Perspective Cavaliere Bayadere", oppure dal tessuto jacquard DEDAR "Babelia". I dettagli in ottone conferiscono a questa lampada un carattere deciso.

Inspired by the atmosphere of Italian bars in the 1930s, where to sip on a Campari surrounded by Depero's artworks, Aperitivo lamp boasts the geometric printed Hermès fabric "Perspective Cavaliere Bayadere" or in the DEDAR jacquard "Babelia" fabric. The design also features polished brass detailing, which add a bold character to this lamp.







Aperitivo Jacquard - Rust



Aperitivo Jacquard - Ivory



Aperitivo Jacquard - Green



Aperitivo

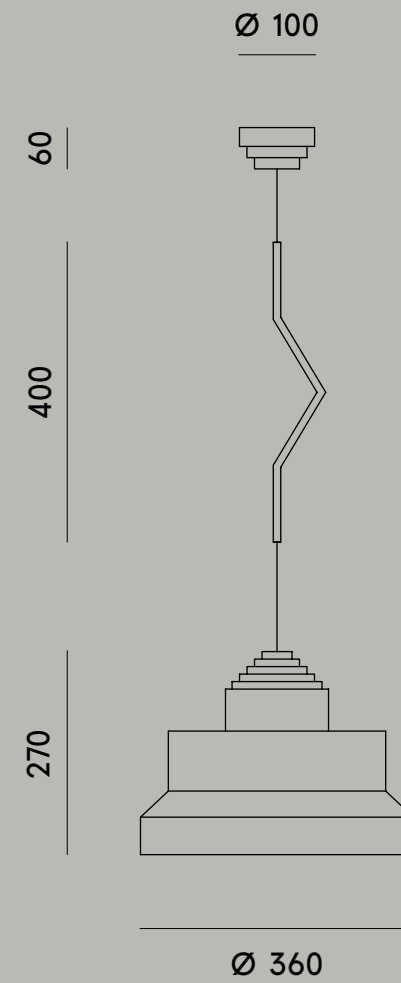

Paralume
Tessuto PES Hermès Perspective Cavaliere Bayadere Outdoor / jacquard Babelia di Dedar

Struttura
Ottone lucido

Specifiche di illuminazione
Fonte luminosa: 1 x E27 Portalampada | E26 Portalampada
Potenza: Max LED 13W
Cavo: Flessibile rivestito in tessuto nero effetto seta, lungo 3 metri
Cablaggio: CE | UL
Compatibile con sistemi dimmerabili

Tutte le dimensioni sono espresse in mm

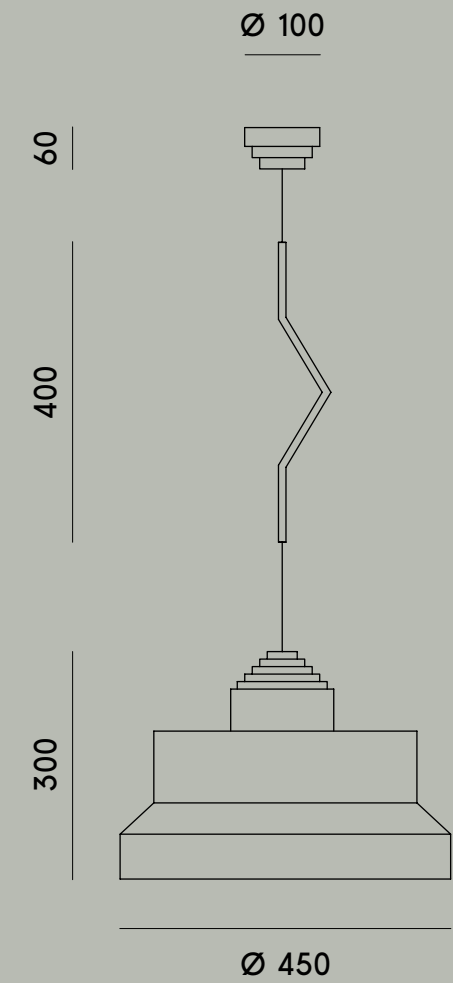

Lampshade
Hermès Perspective Cavaliere Bayadere Outdoor PES fabric / Dedar Babelia jacquard fabric

Structure
Polished brass

Lighting specifications
Light Source: 1 x E27 Bulb Holder | E26 Bulb Holder
Power: Max LED 13W
Cable: Black silk alike fabric flex cable, 3 metres long
Wiring: CE | UL
Compatible with dimmable systems

All dimensions expressed in mm

Circus Chandelier

Ispirato ai lampadari bohémien dei palazzi nobiliari e delle case di lusso del XVIII secolo, Circus Chandelier di SERVOMUTO strizza l'occhio al suggestivo mondo itinerante del circo, con i suoi volumi e la sua palette di colori. Il risultato è un lampadario che cattura l'attenzione, grazie alle notevoli dimensioni e al suo aspetto scenografico.

Inspired by the 18th century Bohemian's decorative fixtures of noble palaces and luxury homes, SERVOMUTO Circus Chandelier winks at the suggestive Circus traveling world, with its colorful palette, typical shapes and patterns. The result is really eye-catching, with its imposing dimensions and spectacular appearance.





Circus Chandelier

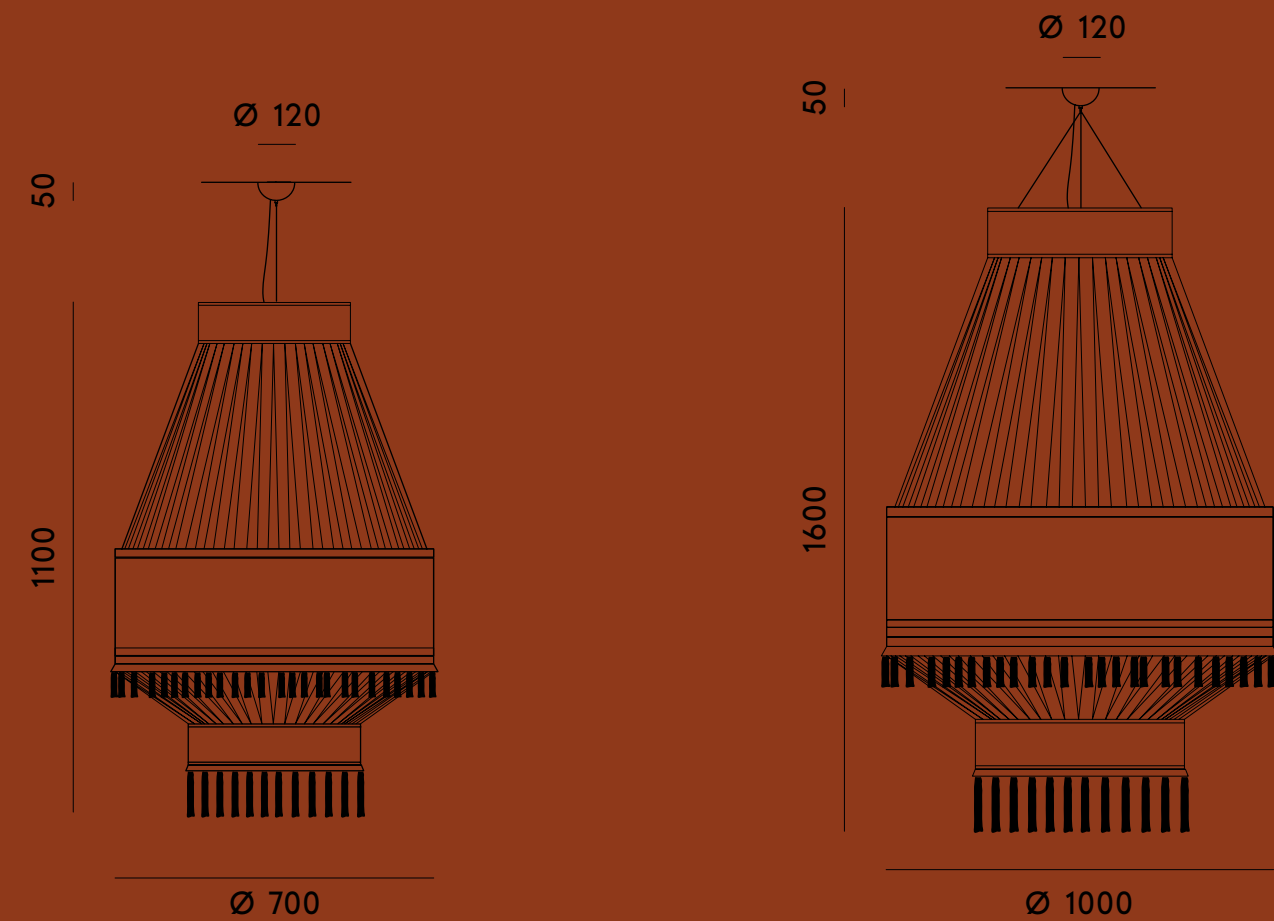

Paralume
Tessuto jacquard e passamanerie di Dedar, fasce in pongé

Rosone a soffitto
Ferro verniciato bianco

Specifiche di illuminazione
Fonte luminosa:
Ø700 - 4 x E27 Portalampada | E26 Portalampada
Ø1000 - 7 x E27 Portalampada | E26 Portalampada
Potenza: Max LED 13W
Cavo: Flessibile rivestito in tessuto nero effetto seta, lunghezza 3 metri
Cablaggio: CE | UL
Compatibile con sistemi dimmerabili

Tutte le dimensioni sono espresse in mm

Lampshade
Jacquard Dedar fabric and trimmings, pongé fabric bends

Ceiling rose
White painted iron

Lighting specifications
Light Source:
Ø700 - 4 x E27 Bulb Holder | E26 Bulb Holder
Ø1000 - 7 x E27 Bulb Holder | E26 Bulb Holder
Power: Max LED 13W
Cable: Black silk alike fabric flex cable, 3 metres long
Wiring: CE | UL
Compatible with dimmable systems

All dimensions expressed in mm

Easy Roof

Le sospensioni Easy Roof sono caratterizzate da forme lineari e inusuali accostamenti di colore. Il tessuto del paralume in cotone è disponibile in tre diverse tinte unite con rifiniture e frange a contrasto.

The Easy Roof series is all about plain shapes and unusual color combination. The lampshade cotton fabric is presented in block colors with contrasting trimmings and fringing around the bottom rim.







Easy Roof - Meringa



Easy Roof - Megafono



Easy Roof - Anemone

Easy Roof

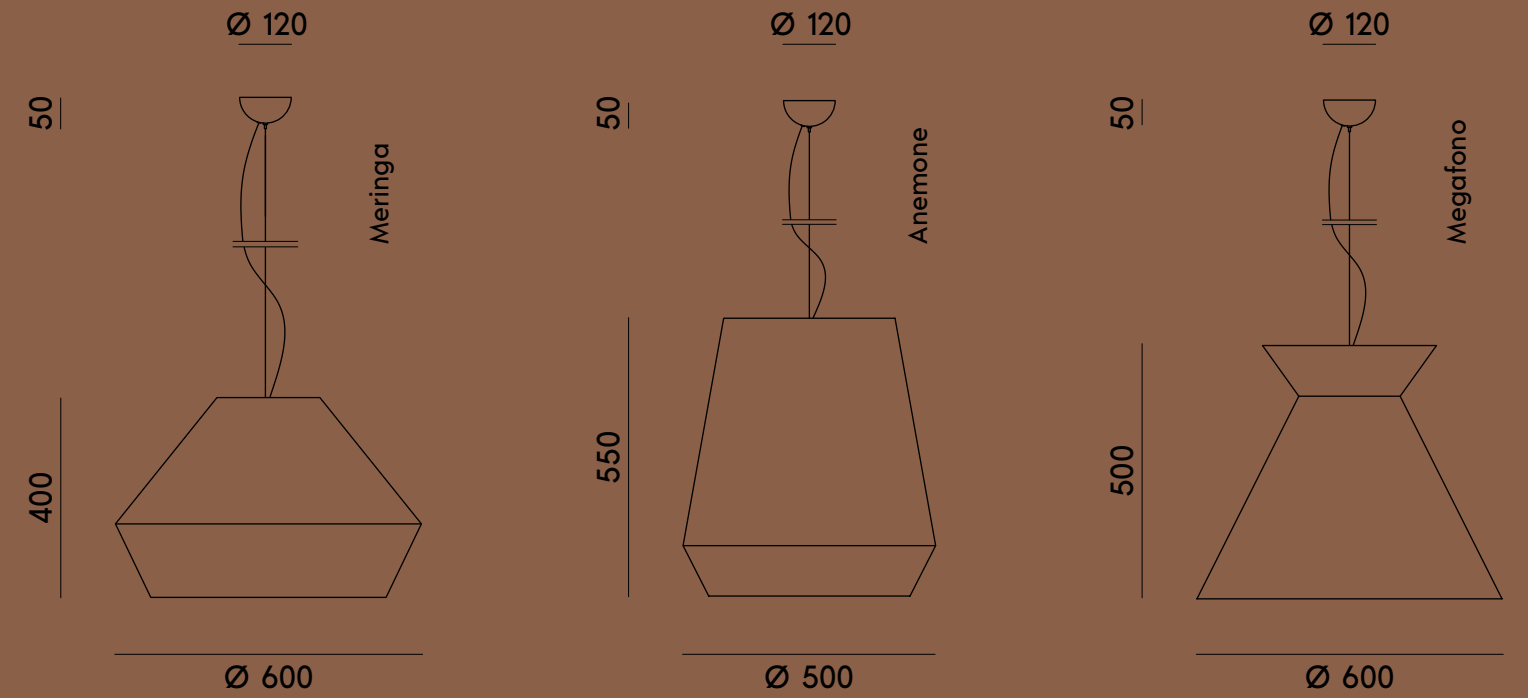

Paralume
Cotone con passamanerie e frange a contrasto

Rosone a soffitto
Ferro verniciato bianco

Specifiche di illuminazione
Fonte luminosa: 1 x E27 Portalampada | E26 Portalampada
Potenza: Max LED 13W
Cavo: Flessibile rivestito in tessuto bordeaux effetto seta, lunghezza 3 metri
Cablaggio: CE | UL
Compatibile con sistemi dimmerabili

Tutte le dimensioni sono espresse in mm

Lampshade
Cotton with contrasting trimmings and fringes

Ceiling rose
White painted iron

Lighting specifications
Light Source: 1 x E27 Bulb Holder | E26 Bulb Holder
Power: Max LED 13W
Cable: Bordeaux silk alike fabric flex cable, 3 metres long
Wiring: CE | UL
Compatible with dimmable systems

All dimensions expressed in mm

Fez

Ispirato al Tarboosh, il tipico copricapo rosso senza tesa, il lampadario Fez prende il nome dall'omonima città marocchina. I suoi colori – blu Majorelle e tangerine – sono un chiaro rimando ai lussuosi giardini di Marrakech e alle roventi dune di Merzouga. Le misure oversize lo rendono un elemento di arredo attraente e singolare.

Inspired by the Tarboosh, the typical red brimless bennet, our pendant lamp is named after the Moroccan city of Fez. Its colors – Majorelle blue and tangerine – are a clear reference to the luxurious gardens of Marrakech and to the scorching sands of the Merzouga dunes. Its oversize dimensions make it an alluring and offbeat piece of furniture.





Fez

Fez

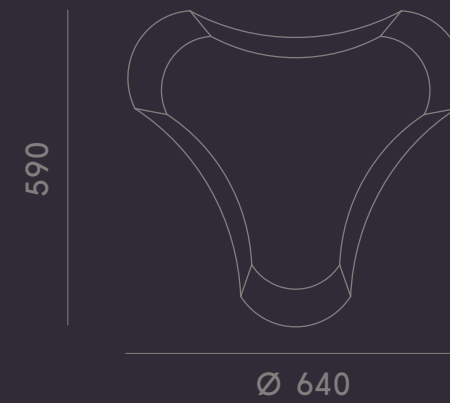
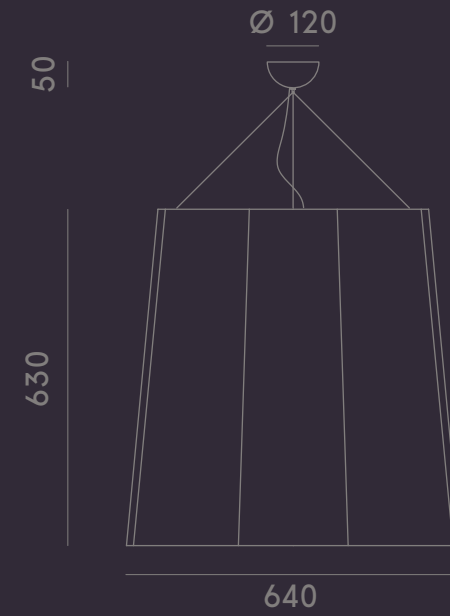

Paralume
Cotone con passamanerie a contrasto

Rosone a soffitto
Ferro verniciato bianco

Specifiche di illuminazione
Fonte luminosa: 1 x E27 Portalampada | E26 Portalampada
Potenza: Max LED 13W
Cavo: Flessibile rivestito in tessuto nero effetto seta, lungo 3 metri
Cablaggio: CE | UL
Compatibile con sistemi dimmerabili

Tutte le dimensioni sono espresse in mm

Lampshade
Cotton with contrasting trimmings

Ceiling rose
White painted iron

Lighting specifications
Light Source: 1 x E27 Bulb Holder | E26 Bulb Holder
Power: Max LED 13W
Cable: Black silk alike fabric flex cable, 3 metres long
Wiring: CE | UL
Compatible with dimmable systems

All dimensions expressed in mm

Giardino Pendant

Con la sua sofisticata artigianalità la lampada Giardino celebra lo stile eclettico degli anni Cinquanta, quando la borghesia milanese viveva un nuovo benessere, affascinata dal richiamo esotico dei giardini d'inverno nei ristoranti in voga. Il rattan, i tessuti jacquard e le rifiniture a contrasto su un diffusore in pergamena bianca sono rimandi stilistici al lontano oriente e alla cultura della vita all'aperto. Un continuo gioco di stili e di dettagli. Disponibile in quattro versioni per altrettanti motivi: in rosa e panna, in verde e nero, con le losanghe di Lelièvre; in bianco e nero, con le geometrie di Johanna Gullichsen, con fantasia a foglie di Misia.

With its sophisticated craftsmanship, the Giardino lamp celebrates the eclectic style of the 1950s, when the "milanese" bourgeoisie was experiencing a new prosperity and was charmed by the exoticism of trendy restaurants' conservatories. Rattan, jacquard fabrics and contrasting finishes on a white parchment diffuser are stylistic references to the Far East and the culture of outdoor living. Available in four versions: in pink and cream white, in green and black, for Lelièvre's lozenges; in black and white, for motifs by Johanna Gullichsen, and with leaves pattern by Misia.







Giardino Pendant - #1 Black and White



Giardino Pendant - #2 Black and Green



Giardino Pendant - #3 Pink and White



Giardino Pendant - #4 Sand

Giardino Pendant

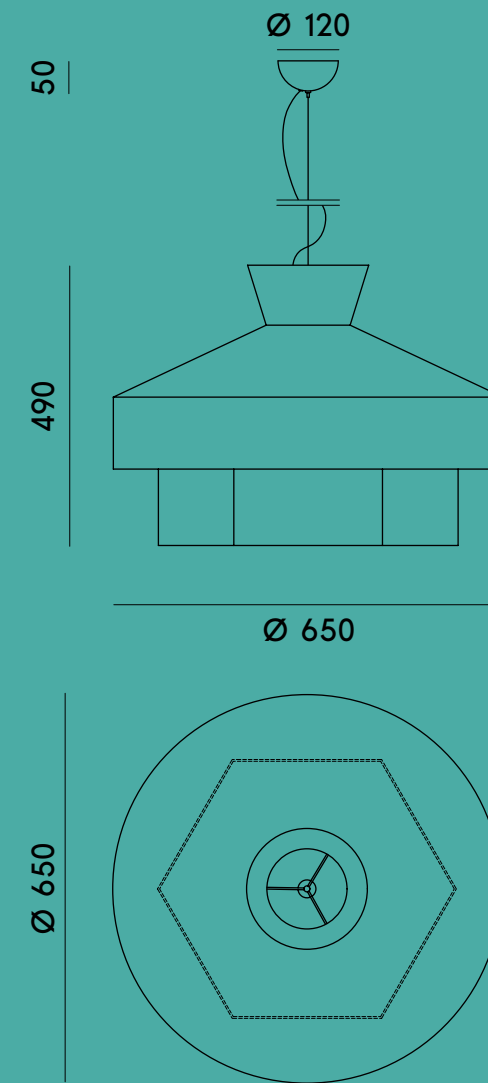

Paralume
Rattan, tessuti jacquard

Diffusore
Pergamena

Rosone a soffitto
Ferro verniciato bianco

Specifiche di illuminazione
Fonte luminosa: 1 x E27 Portalampada | E26 Portalampada
Potenza: Max LED 13W
Cavo: Flessibile rivestito in tessuto nero effetto seta, lunghezza 3 metri
Cablaggio: CE | UL
Compatibile con sistemi dimmerabili

Tutte le dimensioni sono espresse in mm

Lampshade
Rattan, jacquard fabric

Diffuser
Parchment

Ceiling rose
White painted iron

Lighting specifications
Light Source: 1 x E27 Bulb Holder | E26 Bulb Holder
Power: Max LED 13W
Cable: Black silk alike fabric flex cable, 3 metres long
Wiring: CE | UL
Compatible with dimmable systems

All dimensions expressed in mm

Materia

Sono quasi didascaliche le forme semplici e pulite della serie MATERIA. Un design fatto di dettagli, che si mostra sottovoce, con motivi astratti un po' retrò, geometrici e modernisti. Il rivestimento principale è un tessuto in puro lino europeo di Dedar, ricamato e impreziosito con un nastro in cotone spalmato che gli conferisce un aspetto tridimensionale, tattile. MATERIA si declina in tre varianti: singola, doppia e tripla, a creare un grappolo di lampade con altezza regolabile (grazie a una carrucola che permette al filo di scorrere allungandosi o accorciandosi di 90 cm).

Tutti i tessuti sono puro lino 100%, i componenti in acciaio spazzolato e in legno verniciato. MATERIA ha la forza di una lampada senza tempo e la versatilità di una sospensione, che può adattarsi in qualsiasi ambiente, per rispondere alle esigenze di tutti.

The shapes of the MATERIA lamps are the quintessential simplicity and neatness. MATERIA design makes up of details and is subdued with slightly retro, geometric, and modernist abstract motifs. A melancholic inspiration, that is nevertheless craving to enrich the present. The main cover is a pure european long-staple linen fabric by Dedar, embroidered and embellished with a coated cotton ribbon with a 3Dish tactile look.

MATERIA comes in three variants: single, double, and triple, to create a cluster of lamps with adjustable height (a pulley allows the wire to slide lengthening or shortening by 90 cm).

All the fabrics are 100% pure linen, with the components in brushed steel and varnished wood.

MATERIA has the strength of a timeless lamp and the versatility of a suspension, which can adapt to any environment, to meet everyone's needs.







Materia - Single - Terracotta



Materia - Single - Gesso



Materia - Triple - Gesso



Materia - Triple - Terracotta



Materia - Double - Cemento



Materia - Double - Ardesia

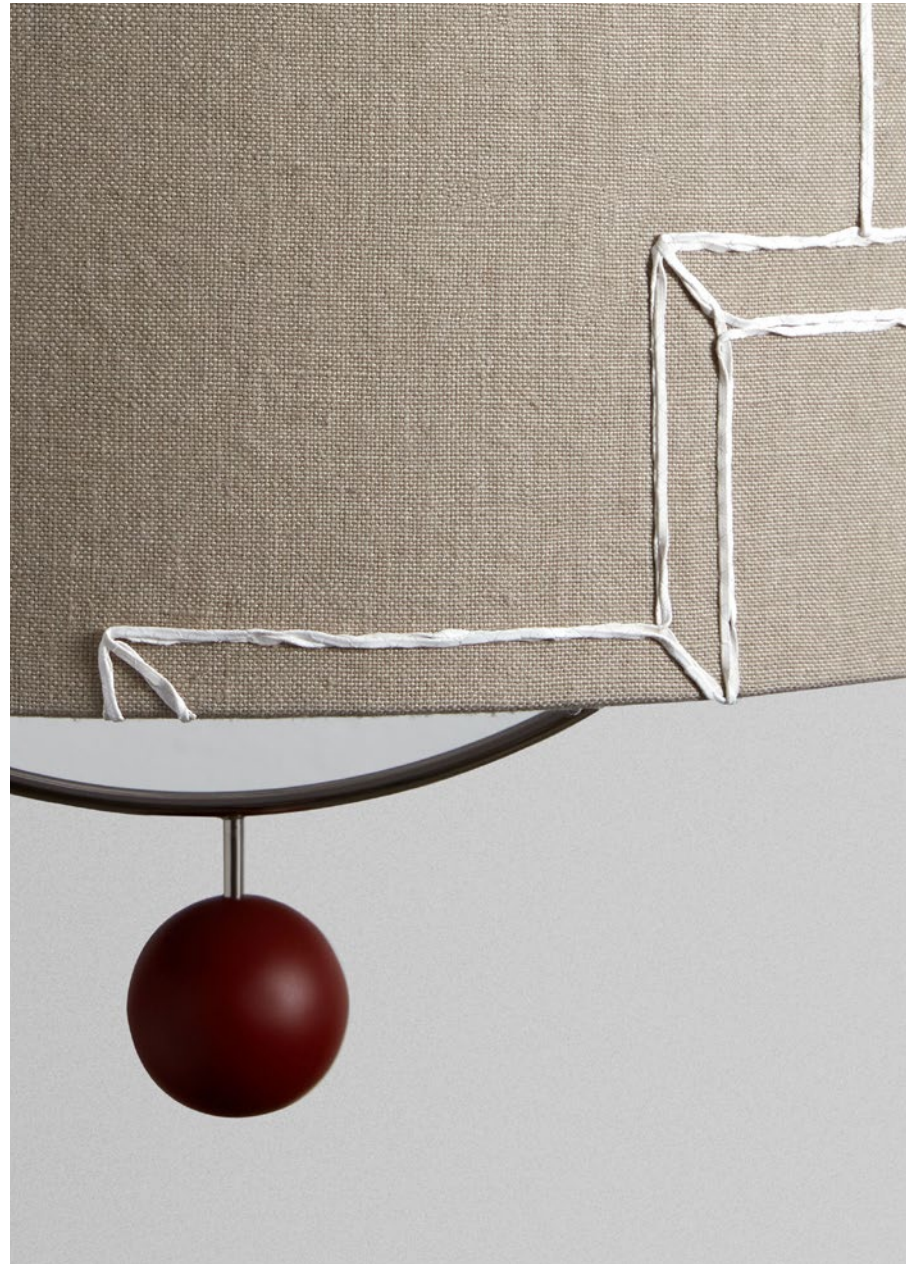

Materia

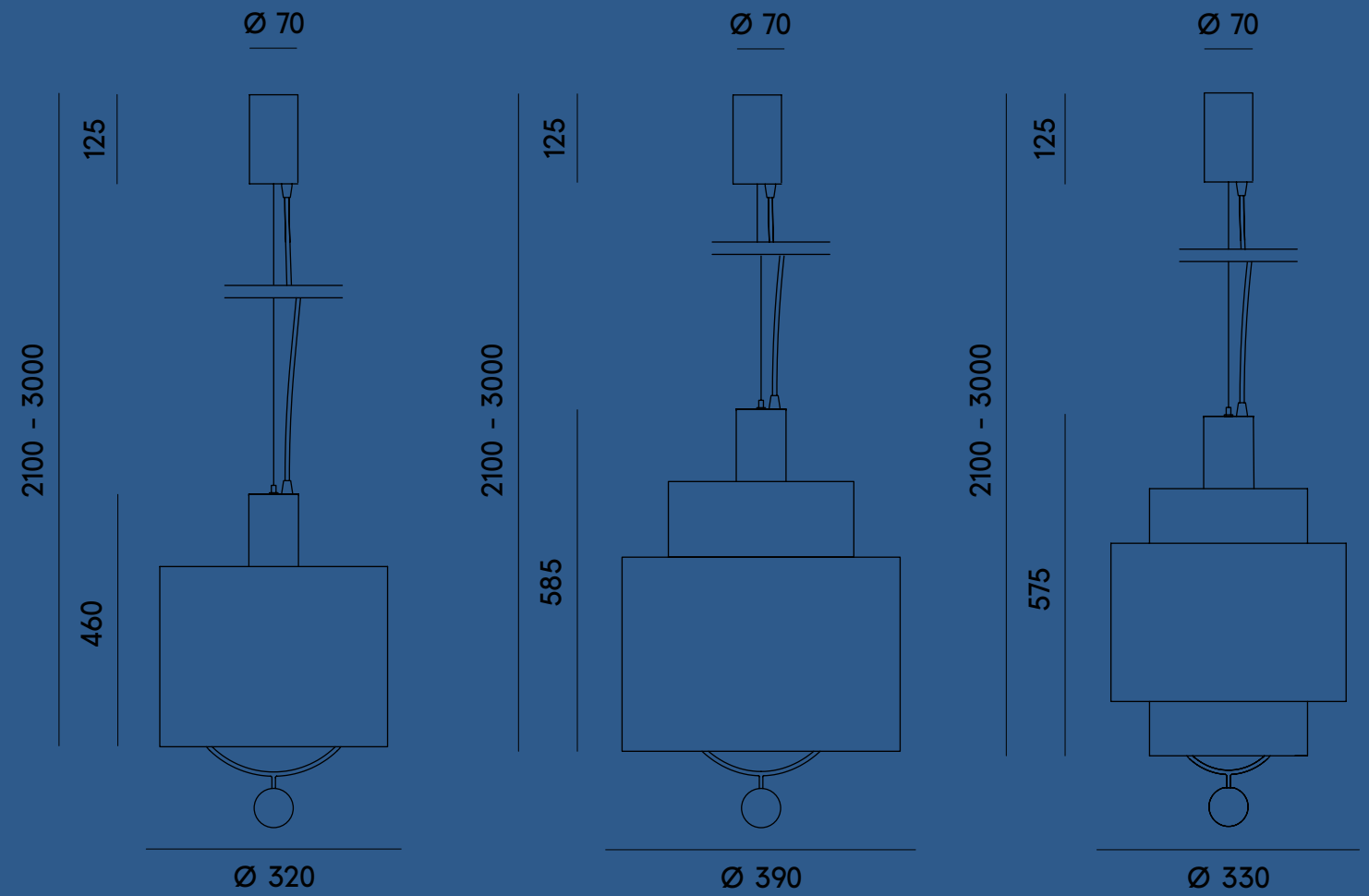

Paralume
Lino di Dedar

Struttura
Ferro cromato e verniciato, legno verniciato

Specifiche di illuminazione
Fonte luminosa: 1 x E27 Portalampada | E26 Portalampada
Potenza: Max LED 13W
Cavo: Flessibile rivestito in tessuto nero effetto seta, lungo 4 metri con un saliscendi con 900mm di movimento
Cablaggio: CE | UL
Compatibile con sistemi dimmerabili

Tutte le dimensioni sono espresse in mm

Lampshade
Dedar linen

Structure
Painted and chromed iron, painted wood

Lighting specifications
Light Source: 1 x E27 Bulb Holder | E26 Bulb Holder
Power: Max LED 13W
Cable: Black silk alike fabric flex cable, 4 metres long equipped with a pulley system with a 900mm range of motion
Wiring: CE | UL
Compatible with dimmable systems

All dimensions expressed in mm

Meringa

Una delle sospensioni iconiche e più versatili di SERVOMUTO. La lampada Meringa è realizzata in puro lino e proposta in cinque diverse combinazioni di colore e due dimensioni, 35 e 60 centimetri di diametro, con cavo in tessuto bordeaux.

One of the most iconic and versatile pendant lamps by SERVOMUTO. The Meringa lamp is realized in pure linen and is available in five different color combinations and two dimensions, 35 and 60 centimeters in diameter, with a burgundy fabric cable.



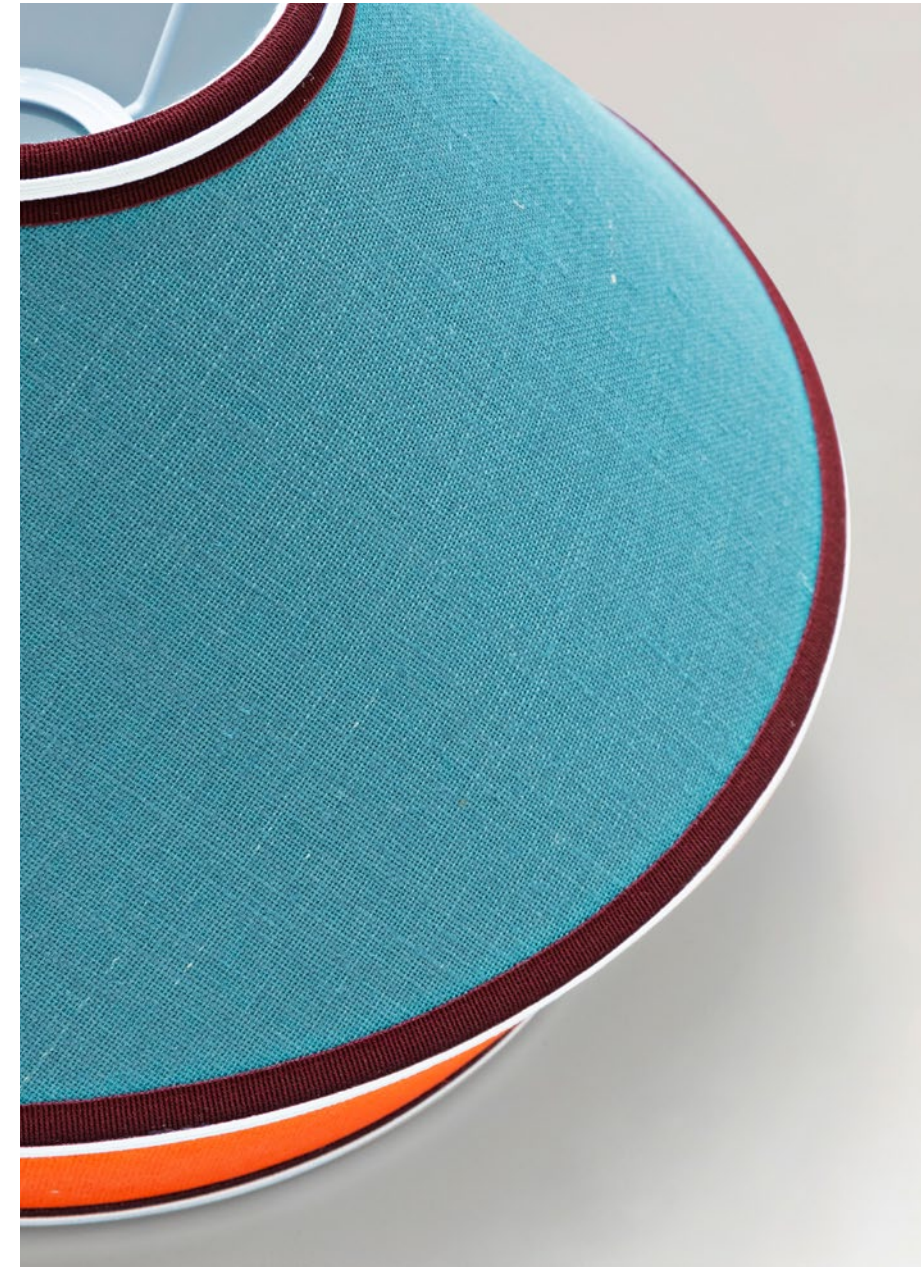



Meringa - #1 Bordeaux/Rust
Ø 350 / 600



Meringa - #2 Light Blue/Rust
Ø 350 / 600



Meringa - #4 Strawberry/Military Green
Ø 350 / 600



Meringa - #5 Light Grey/Blue
Ø 350 / 600



Meringa - #3 Petrol Blue/Strawberry
Ø 350 / 600



Meringa

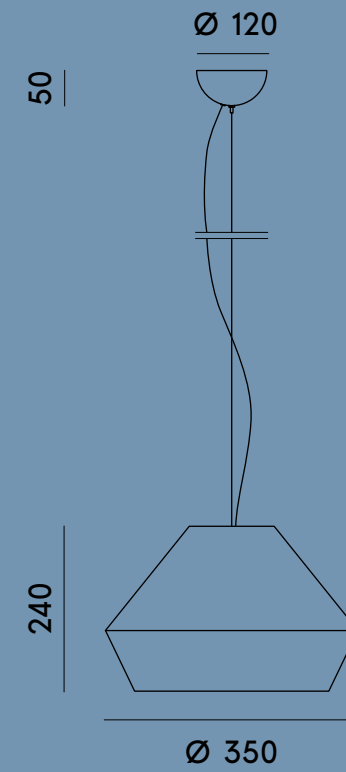

Paralume
Puro lino naturale

Rosone a soffitto
Ferro verniciato bianco

Specifiche di illuminazione
Fonte luminosa: 1 x E27 Portalampada | E26 Portalampada
Potenza: Max LED 13W
Cavo: Flessibile rivestito in tessuto bordeaux effetto seta, lungo 3 metri
Cablaggio: CE | UL
Compatibile con sistemi dimmerabili

Tutte le dimensioni sono espresse in mm

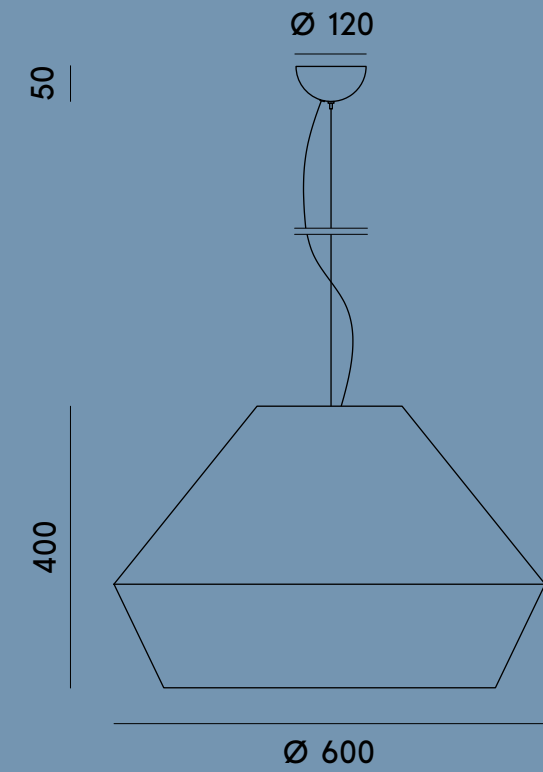

Lampshade
Pure natural linen

Ceiling rose
White painted iron

Lighting specifications
Light Source: 1 x E27 Bulb Holder | E26 Bulb Holder
Power: Max LED 13W
Cable: Bordeaux silk alike fabric flex cable, 3 metres long
Wiring: CE | UL
Compatible with dimmable systems

All dimensions expressed in mm

Otto Pendant

Il design della serie di lampade OTTO risuona dell'eco lontana dell'immaginario fantascientifico di fine anni Sessanta e inizio Settanta. Liberamente ispirata alle illustrazioni dell'epoca di ufo e universi lontanissimi, la sua silhouette si rifà in modo giocoso al mondo dei caroselli del luna park, che tanta parte hanno avuto nel portare in terra un sogno 'spaziale'. OTTO è una sospensione leggera, quasi fluttuante composta da un cappello superiore rivestito in tessuto bouclé di Rubelli o Dedar, che si contrappone, completandosi, a un diafano tronco di cono rovesciato che, formato da fasce di pongè, diventa un vero e proprio diffusore luminoso.

Le lampade sono completamente cucite a mano e vengono presentate in nove differenti varianti di colore. Le fodere in cotone sono ton sur ton con il cappello.

OTTO lamp series design echoes the distant sci-fi imaginary of the late 60s and early 70s. It's inspired by the illustrations of the UFOs era with the very distant universes they used to recall; its silhouette refers in a playful way to the world of amusement park carousels, which have played such a large part in bringing the 'space dream' to Earth. OTTO is an airy, almost floating suspension composed of an upper hat covered in bouclé fabric by Rubelli or Dedar, which completes and contrasts with a diaphanous inverted truncated cone formed by pongè bands, whose actual pose is to become a light diffuser.

The lamps are completely hand-sewn and are presented in nine different melange color variants. The cotton linings are ton sur ton with the hat.



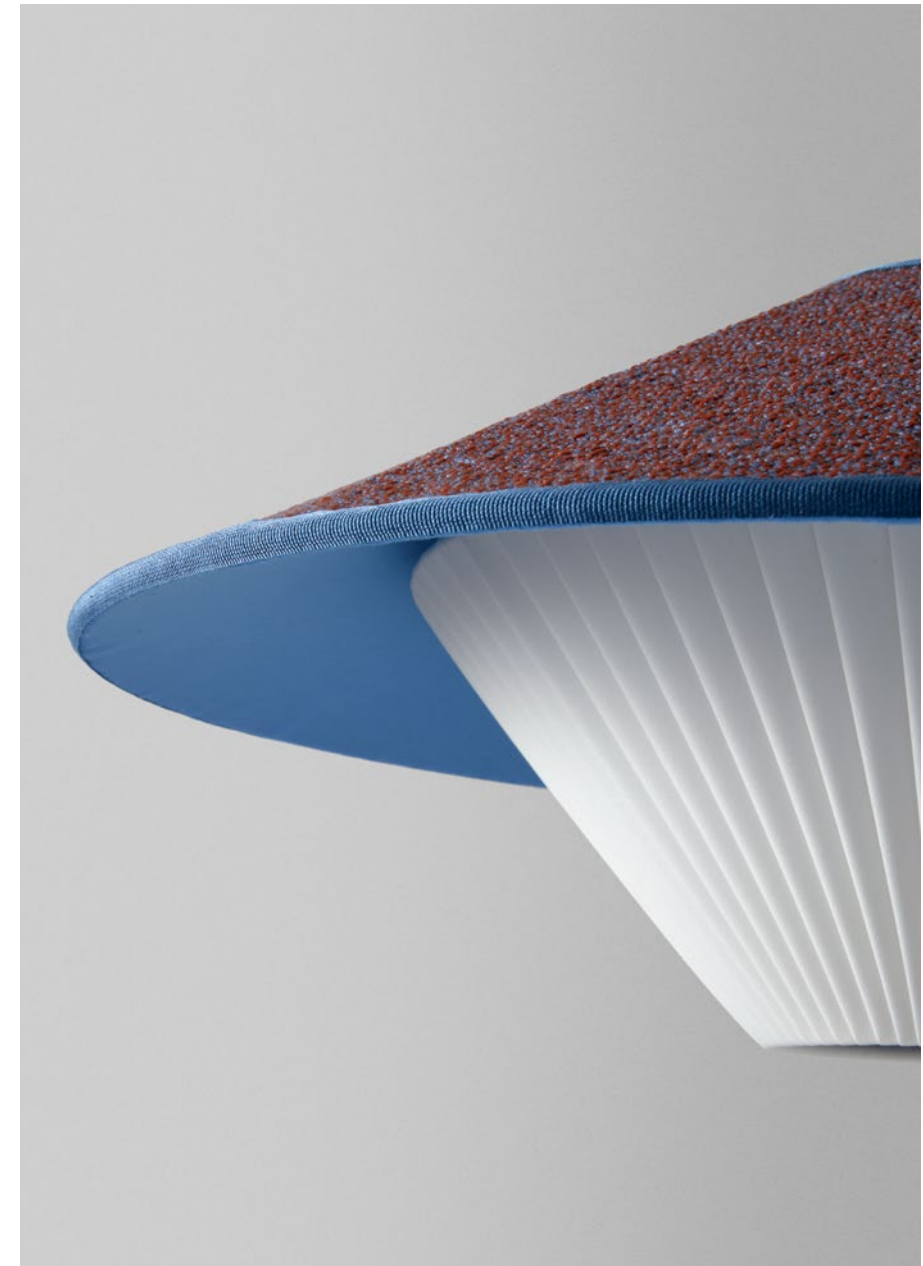



Otto Pendant - Brown
Ø 500 / 700



Otto Pendant - Green
Ø 500 / 700



Otto Pendant - Ecrù
Ø 500 / 700



Otto Pendant - Cobalt
Ø 500 / 700



Otto Pendant - Pink
Ø 500 / 700



Otto Pendant - Azure
Ø 500 / 700



Otto Pendant - Yellow
Ø 500 / 700



Otto Pendant - Tender Rose
Ø 500 / 700



Otto Pendant - Salt and Pepper
 Ø 500 / 700

Otto Pendant

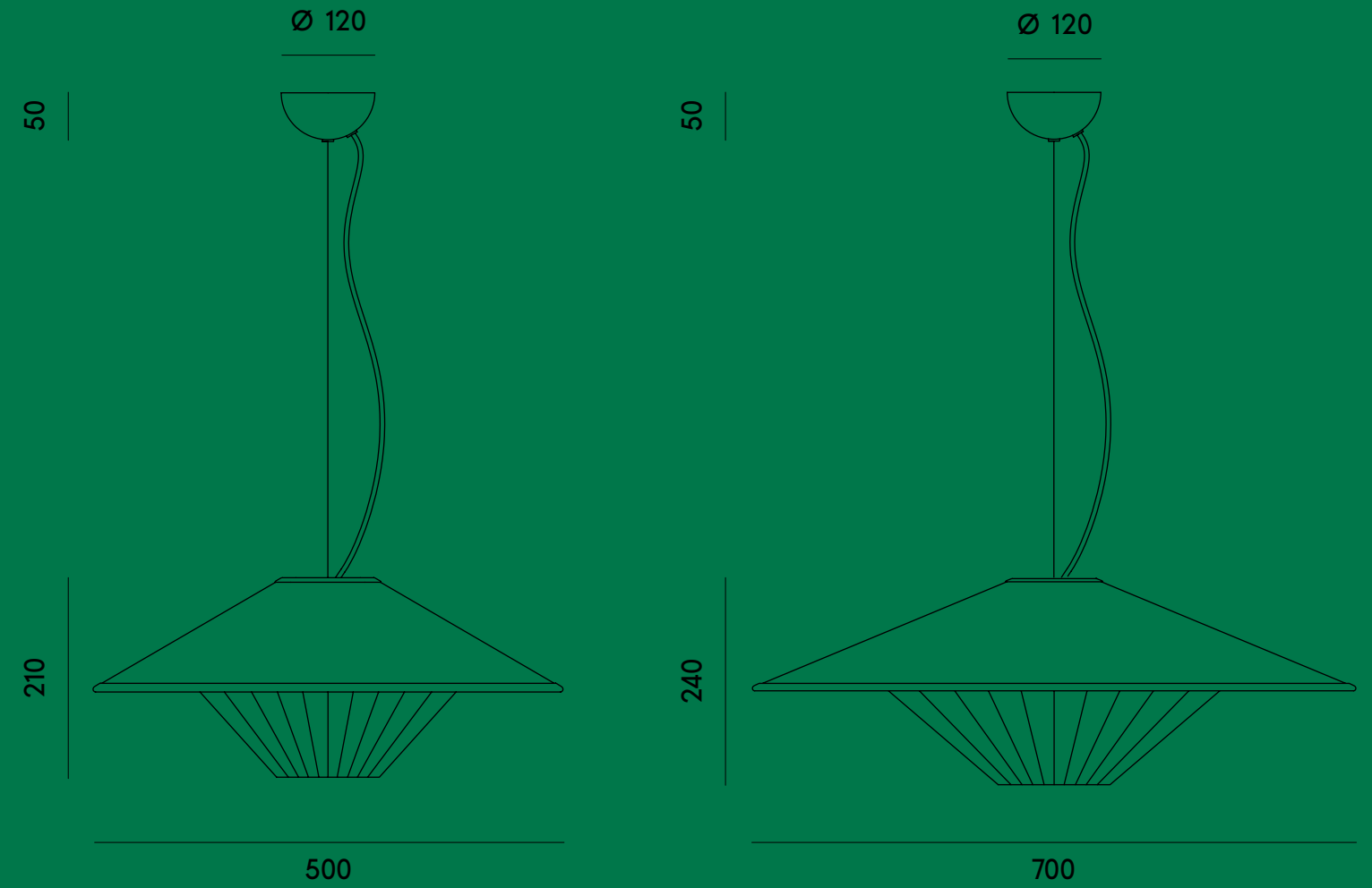

Paralume Superiore
 Tessuto di Rubelli / Dedar

Paralume Inferiore
 Fasce in pongé plissettato

Rosone a soffitto
 Ferro verniciato bianco

Specifiche di illuminazione:
 Fonte luminosa: 1 x E27 Portalampada | E26 Portalampada
 Potenza: Max LED 13W
 Cavo: Flessibile rivestito in tessuto nero effetto seta, lungo 3 metri
 Cablaggio: CE | UL
 Compatibile con sistemi dimmerabili

Tutte le dimensioni sono espresse in mm

Upper Lampshade
 Rubelli / Dedar fabric

Lower Lampshade
 Pleated pongé bends

Ceiling rose
 White painted iron

Lighting specifications:
 Light Source: 1 x E27 Bulb Holder | E26 Bulb Holder
 Power: Max LED 13W
 Cable: Black silk alike fabric flex cable, 3 metres long
 Wiring: CE | UL
 Compatible with dimmable systems

All dimensions expressed in mm

Palazzi

Palazzi è ispirata all'architettura di Aldo Rossi, in particolare al suo Teatro del Mondo ambientato nella laguna di Venezia durante la Biennale di Architettura del 1980. L'impalpabile tessuto plissettato Kvadrat dà vita a eleganti giochi di luce, rivelando la struttura in ottone lucido della lampada e i tre tubi a led realizzati su misura.

Palazzi is inspired by the visionary and playful architecture of Aldo Rossi, specifically by his Teatro del Mondo, an ephemeral project set afloat on the Venice lagoon during the 1980 Architecture Biennale. The light-weight pleated Kvadrat fabric reveals the polished brass structure of the lamp and the three led tubes, resulting in multiple and elegant light plays.







Palazzi - Green



Palazzi - Blue



Palazzi - Grey

Palazzi

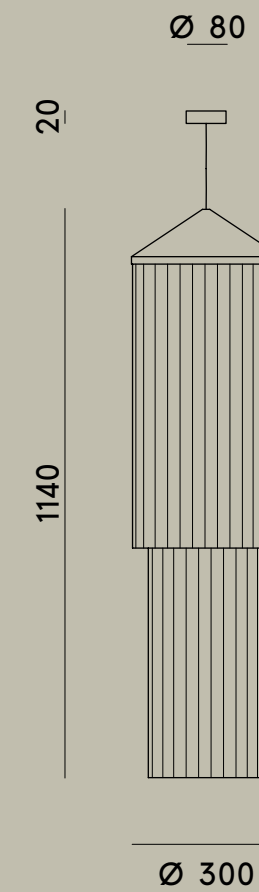

Paralume
Tessuto leggero in PES plissettato a vapore di Kavrat

Struttura
Ottone lucidato

Rosone a soffitto
Ferro verniciato nero

Specifiche di illuminazione
Fonte luminosa: 3 x Strip LED, 2700K (Incluse)
Potenza: 30W
Cavo: Flessibile rivestito in tessuto nero effetto seta, lungo 3 metri
Cablaggio: CE | UL
Non dimmerabile

Tutte le dimensioni sono espresse in mm

Lampshade
Light weight steam-pleated Kvadrat PES fabric

Structure
Polished brass

Ceiling rose
Black painted iron

Lighting specifications
Light Source: 3 x Strip LED, 2700K (included)
Power: 30W
Cable: Black silk alike fabric flex cable, 3 metres long
Wiring: CE | UL
Not dimmable

All dimensions expressed in mm

Venus

Le sospensioni sono liberamente ispirate alle sinuosità ed alle curve del corpo femminile e sono state realizzate in metallo e lycra: uno scheletro esile ed una pelle morbida ed elastica che lo riveste.

Proprio come accade per il corpo umano, il tessuto è immaginato come un abito da indossare e cambiare a piacimento, vestendo e svestendo le forme in un gioco di seduzione.

Denominata inizialmente "La fibra K", la lycra nasce negli anni '50 entrando immediatamente nella quotidianità delle signore diventando subito un materiale che ne esalta le forme proprio grazie alla sua caratteristica estremamente elastica che avvolge perfettamente il corpo: guaine di contenimento, calze, costumi da bagno, fino alle passerelle dove è tornata di gran moda anche negli ultimi anni.

Nel settore del design, la lycra è stata sperimentata anche nell'arredo da alcuni grandi maestri del '900: perfetto come rivestimento, ideale nell'illuminazione per la sua trasparenza.

The suspensions are freely inspired by the sinuosity and curves of the female body and have been made of metal and lycra: a slender skeleton and a soft and elastic skin that covers it.

Just as it happens with the human body, the fabric is imagined as a garment to be worn and changed at will, dressing and undressing the shapes in a game of seduction.

Initially called "The K fiber", lycra was born in the 1950s and immediately entered the daily life of ladies, suddenly becoming a skin enhancing their shapes thanks to its extremely elastic characteristic that perfectly wraps the body: containment sheaths, tights, swimwear.

It also has made a comeback to the catwalks in recent years giving birth to some of the most iconic garments of many fashion shows.

In the design field, Lycra has also been experimented in furniture by some great masters of the 1900s: perfect as a coating, ideal for lighting due to its transparency.

Designer: Serena Confalonieri.







Venus #1 - Body/Pink

Venus #1 - Body/Orange

Venus #2 - Burgundy/Pink

Venus #2 - Burgundy/Azure



Venus #1 - Body/Azure

Venus #1 - White

Venus #2 - Orange/Azure

Venus #2 - White



Venus #3 - Burgundy/Pink

Venus #3 - Body/Pink



Venus #3 - Orange/Pink

Venus #3 - White

Venus

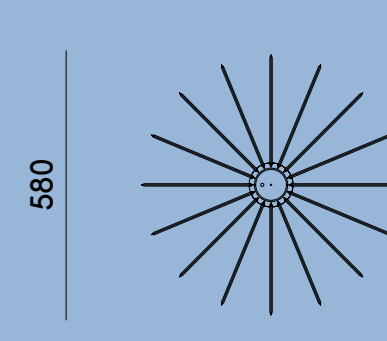
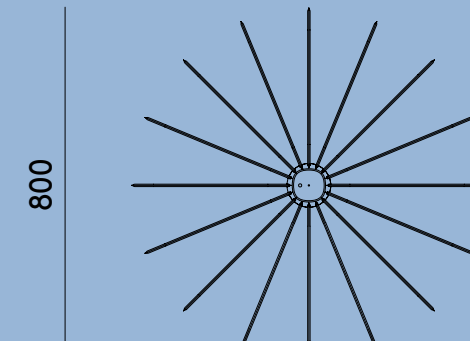
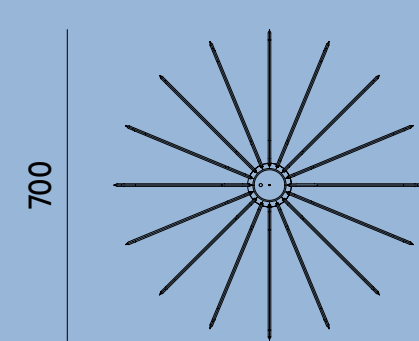
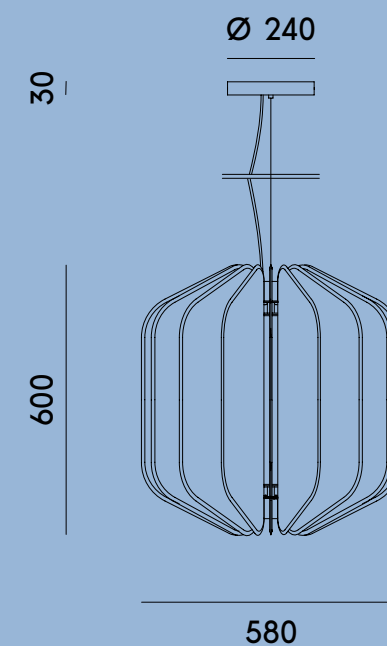
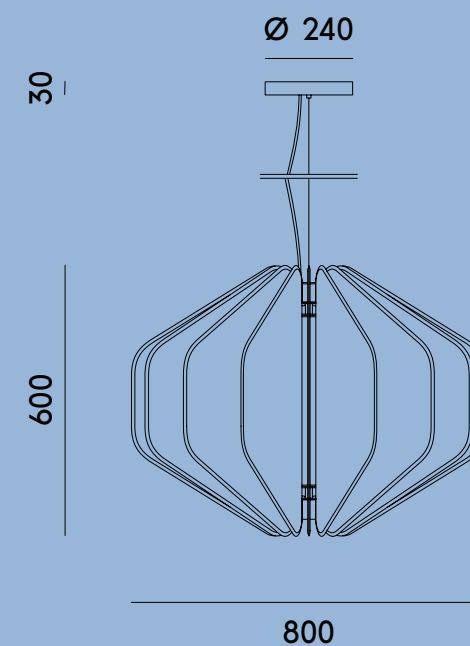
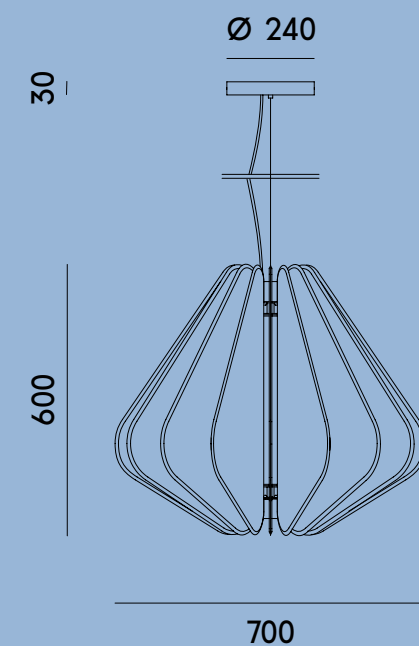

Paralume
Lycra termosaldata

Struttura
Ferro e alluminio cromato

Specifiche di illuminazione

Fonte luminosa:
1 x 29W Strip LED, 3000K, CRI>80 (inclusa)
1 x 9W Scheda LED, 3000K, CRI>80 (inclusa)

Potenza: 38W

Cavo: Flessibile rivestito in tessuto nero effetto seta, lungo 3 metri

Cablaggio: CE | UL
Compatibile con sistemi dimmerabili su richiesta

Tutte le dimensioni sono espresse in mm

Lampshade
Heat sealed lycra

Structure
Chromed iron and aluminium

Lighting specifications

Light Source:
1 x 29W Strip LED, 3000K, CRI>80 (included)
1 x 9W LED Board, 3000K, CRI>80 (included)

Power: 38W

Cable: Black silk alike fabric flex cable, 3 metres long

Wiring: CE | UL
Compatible with dimmable system upon request

All dimensions expressed in mm

WALL

Bikini

L'idea dell'applique Bikini nasce dal dialogo che si crea tra materiali con caratteristiche molto diverse tra loro. La larga trama del rattan lascia intravedere la luce come da una gelosia, e un foglio d'oro la riflette. Le classiche righe regimental inseriscono il tema del colore nell'oggetto luminoso.

The idea for our Bikini lamp arises from the dialogue between vastly different materials. Rattan, with its wide weave that allows the light to be glimpsed as if through a jalousie, and a golden sheet, which reflects it. The classic regimental stripes suggest the motif of color in this luminous object.



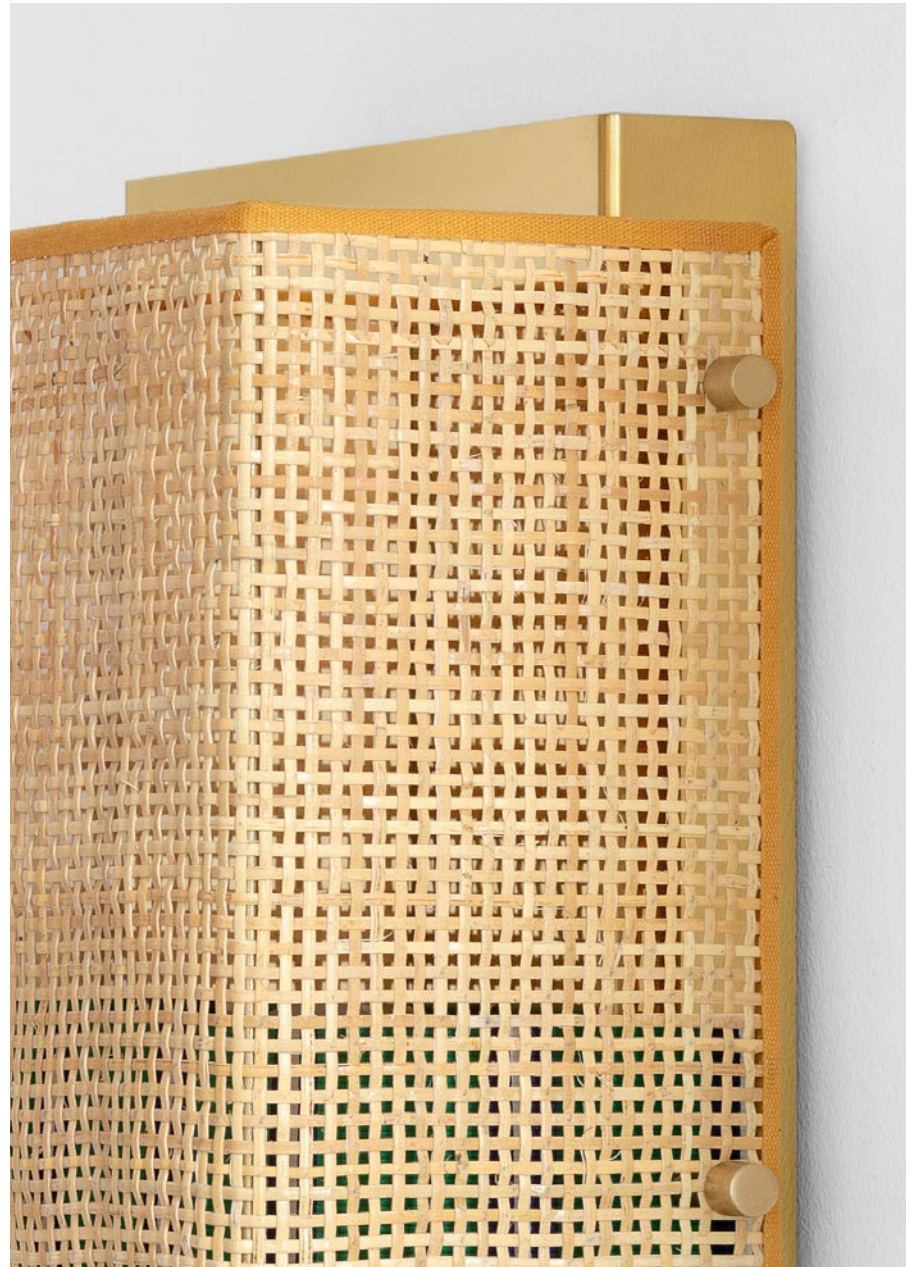

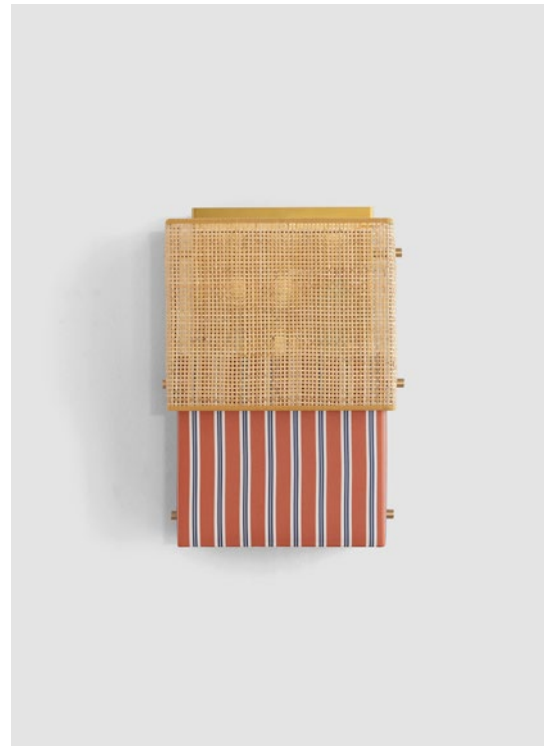

Bikini - Rust

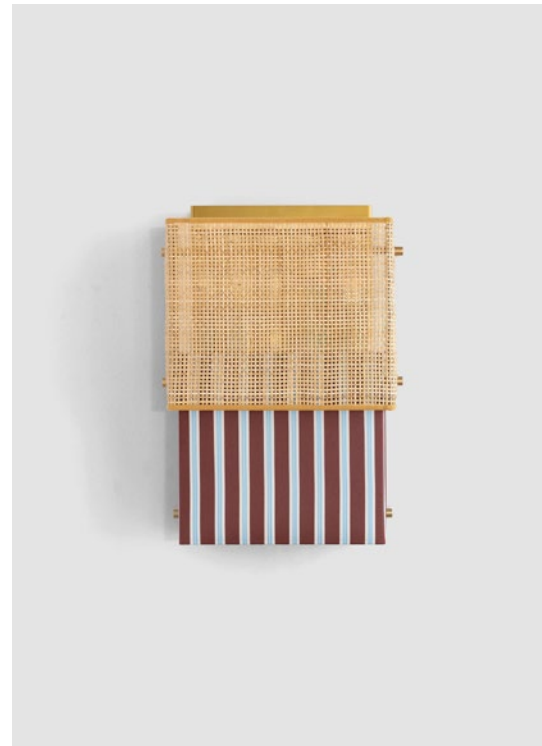

Bikini - Bordeaux

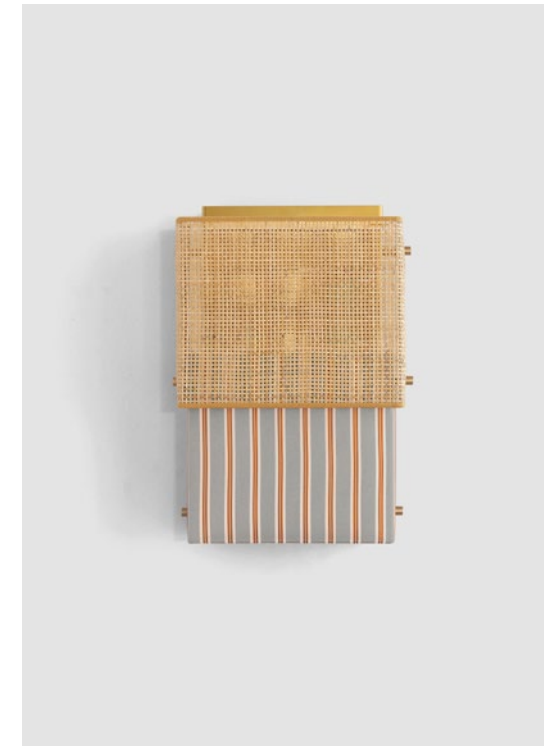

Bikini - Grey

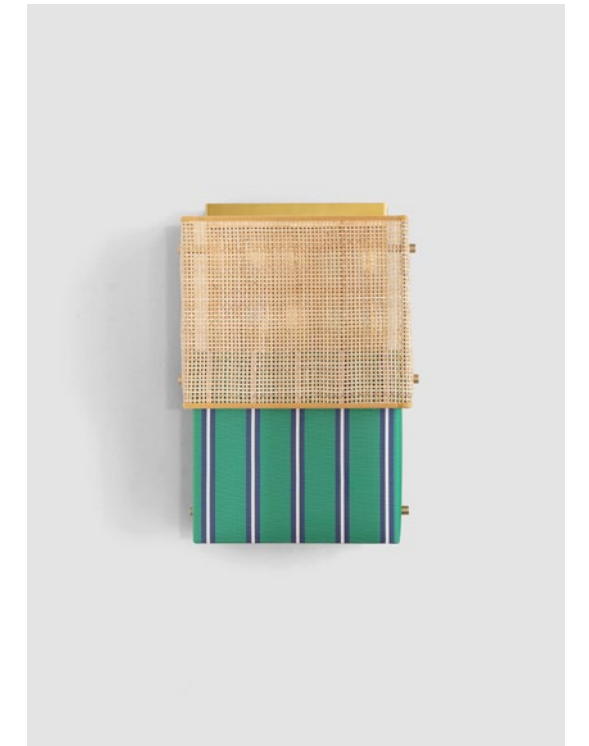

Bikini - Green



Bikini - Terracotta

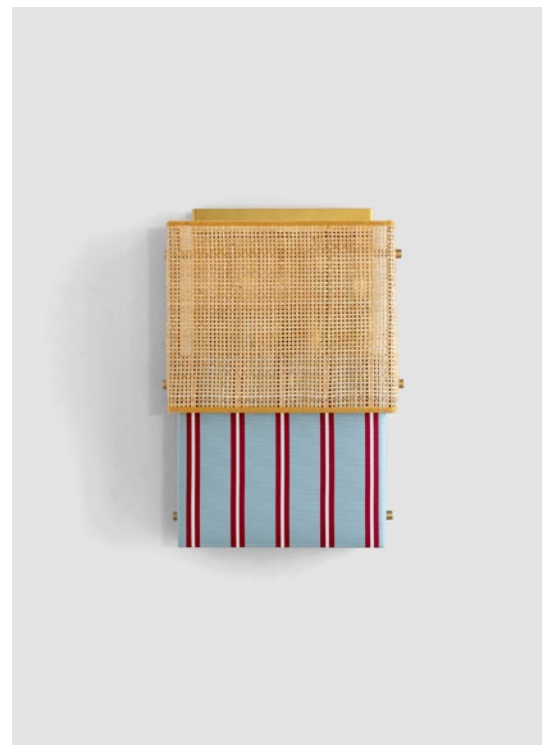

Bikini - Light Blue

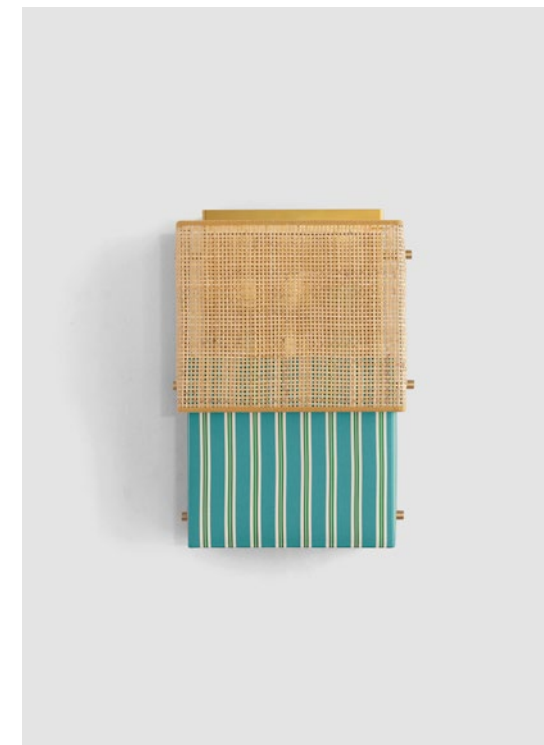

Bikini - Turquoise



Bikini - White

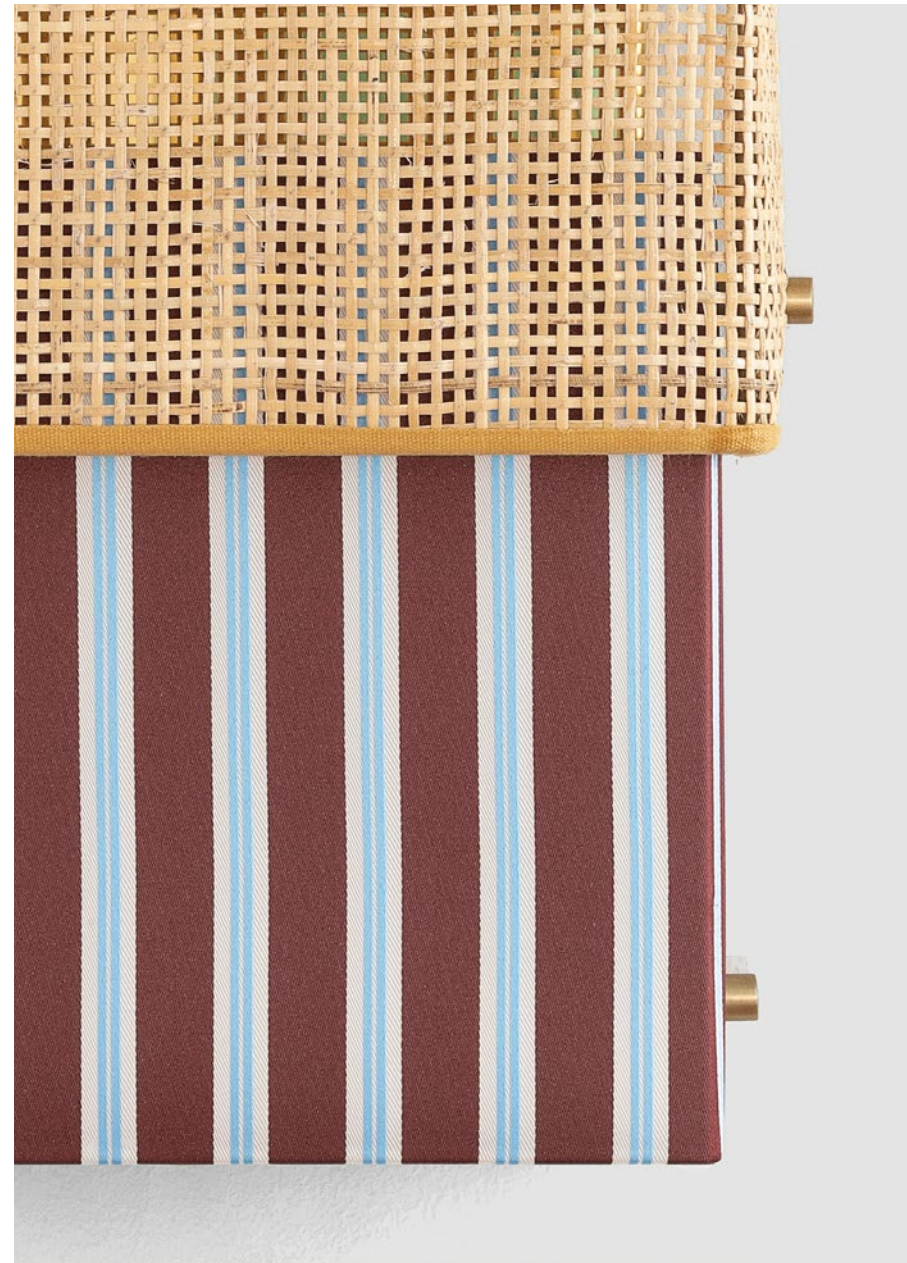

Bikini

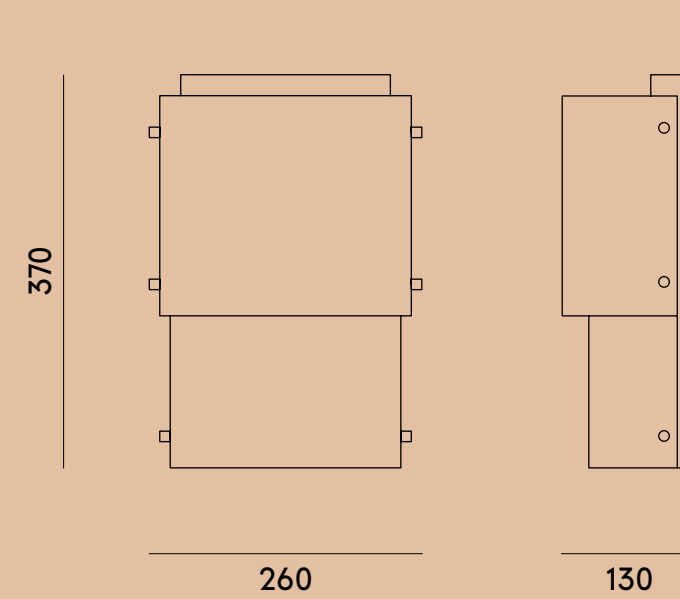

Paralume superiore
Rattan

Paralume inferiore
Tessuto Trevira di Dedar / lino bianco

Struttura
Acciaio dorato inossidabile

Specifiche di illuminazione
Fonte luminosa: 1 x scheda LED, 3000K, CRI>80 (inclusa)
Potenza: 10W
Cablaggio: CE | UL
Non dimmerabile

Tutte le dimensioni sono espresse in mm

Upper lampshade
Rattan

Lower lampshade
Dedar Trevira fabric / white linen

Structure
Golden stainless steel

Lighting specifications
Light Source: 1 x LED Board, 3000K, CRI>80 (included)
Power: 10W
Wiring: CE | UL
Not dimmable

All dimensions expressed in mm

Birds & Butterflies

La collezione Birds & Butterflies è realizzata con una riproduzione di stampe vintage risalenti al 1750, parte dell'archivio di SERVOMUTO. Composta da quattordici diversi soggetti raffiguranti uccelli selvatici e farfalle.

Our Birds & Butterflies collection is a reproduction of a 1750's vintage illustration, part of SERVOMUTO archives, made up of fourteen different subjects depicting wild birds and butterflies.



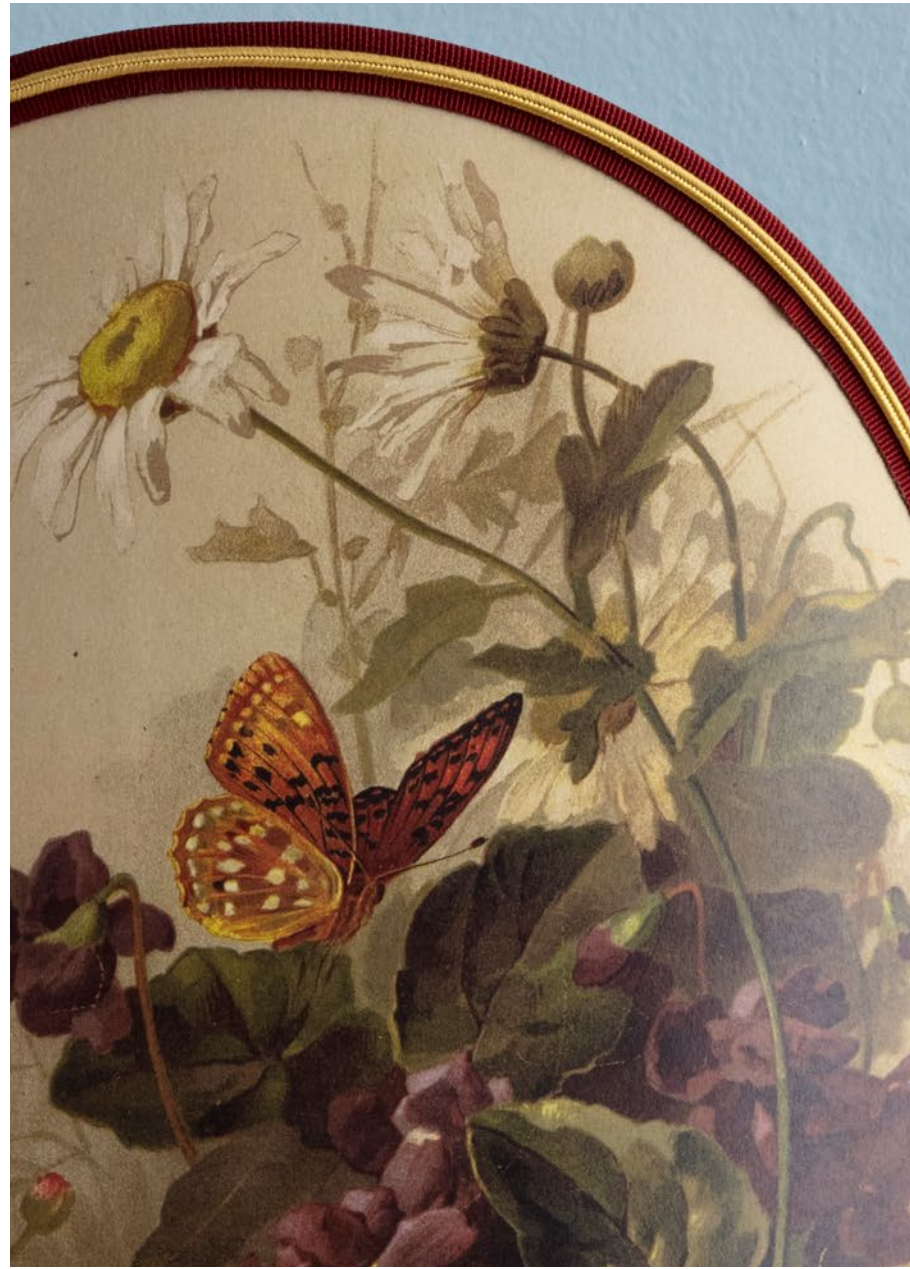

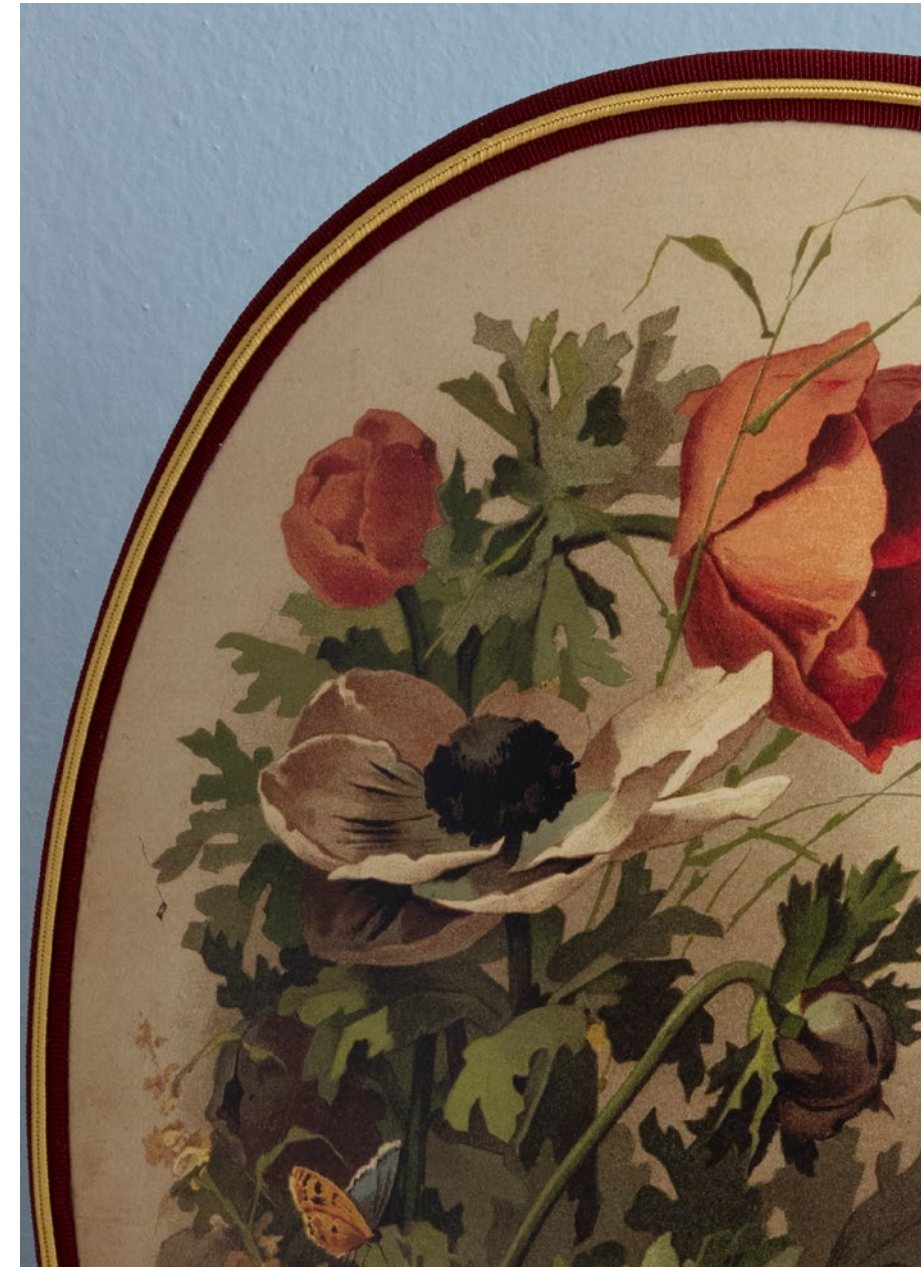



Birds & Butterflies - #1



Birds & Butterflies - #2



Birds & Butterflies - #5



Birds & Butterflies - #6



Birds & Butterflies - #3



Birds & Butterflies - #4



Birds & Butterflies - #7



Birds & Butterflies - #8



Birds & Butterflies - #9



Birds & Butterflies - #10



Birds & Butterflies - #13



Birds & Butterflies - #11



Birds & Butterflies - #12



Birds & Butterflies - #14

Birds & Butterflies

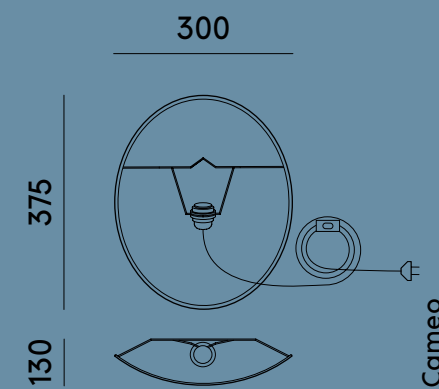
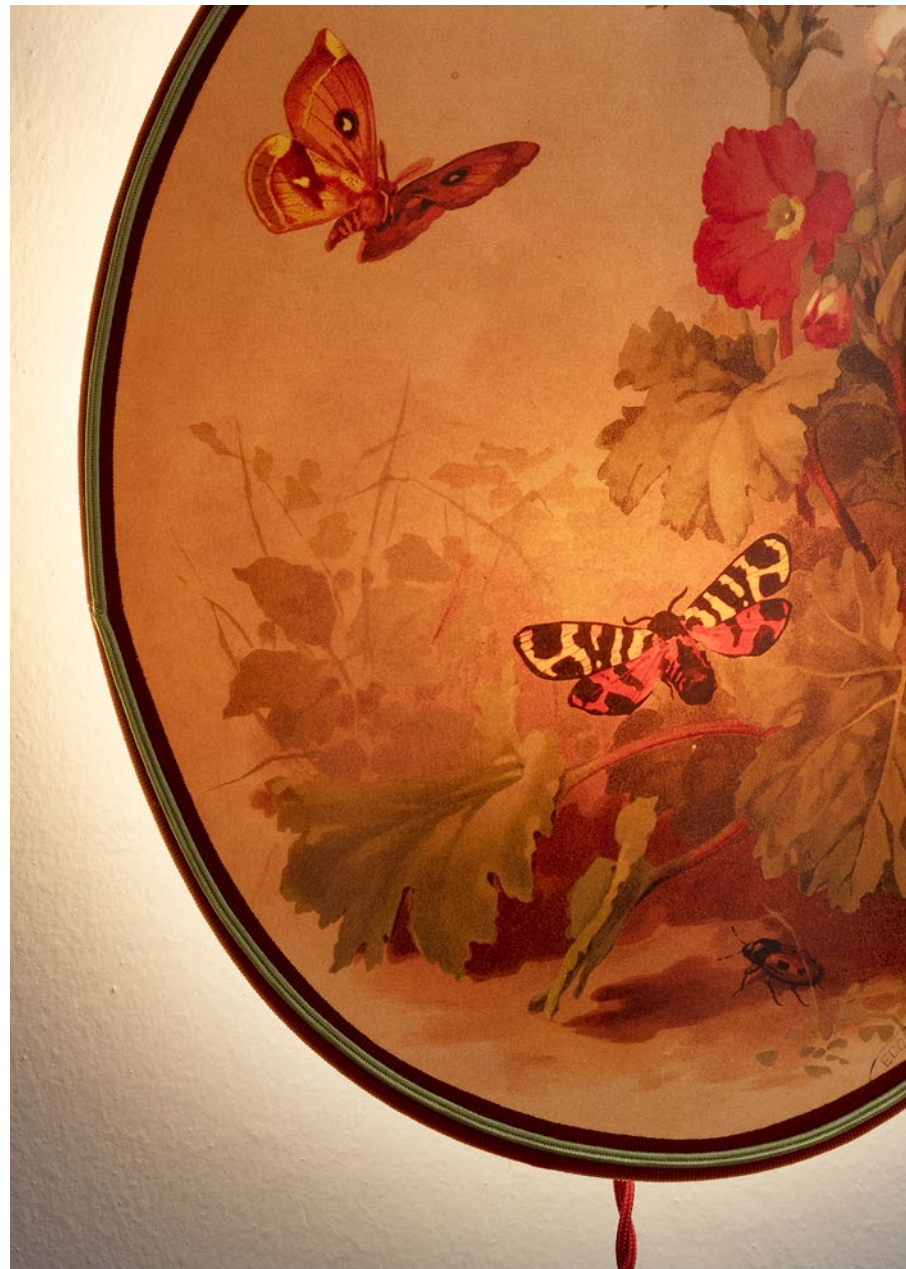

Paralume
Carta stampata

Specifiche di illuminazione
Fonte luminosa: 1 x E27 Portalampada | E26 Portalampada
Potenza: Max LED 13W
Cavo: A treccia rivestito in tessuto bordeaux effetto seta, lungo 2 metri
Spina: Presa Euro - Tipo C - 2 poli | Presa USA - Tipo A - 2 poli
Interruttore: sul cavo
Cablaggio: CE | UL
Non dimmerabile

Tutte le dimensioni sono espresse in mm

Lampshade
Printed paper

Lighting specifications
Light source: 1 x E27 Bulb Holder | E26 Bulb Holder
Power: Max LED 13W
Cable: Bordeaux silk alike fabric braided cable, 2 metres long
Plug: Euro Plug - Type C - 2 pins | USA Plug - Type A - 2 pins
Switch: On the cable
Wiring: CE | UL
Not dimmable

All dimensions expressed in mm

Chalk

Le lampade della collezione Chalk si ispirano agli stucchi decorativi in gesso bianco delle antiche dimore nobiliari del Sud Italia. Adatte a qualsiasi interno, sono un classico senza tempo. Collezione composta da quattro diverse applique dalle sagome barocche, rivestite in puro lino bianco e rifinite da passamanerie in tinta.

The Chalk collection is inspired by the decorative coating "white stucco" of ancient noble homes of Southern Italy. Chalk big sconces are a neutral, yet noteworthy and timeless classic addition to any interior. The collection features four different baroque wall lampshade silhouettes in pure white linen with matching trimmings.



Chalk





Chalk #1



Chalk #2



Chalk #3



Chalk #4

Chalk

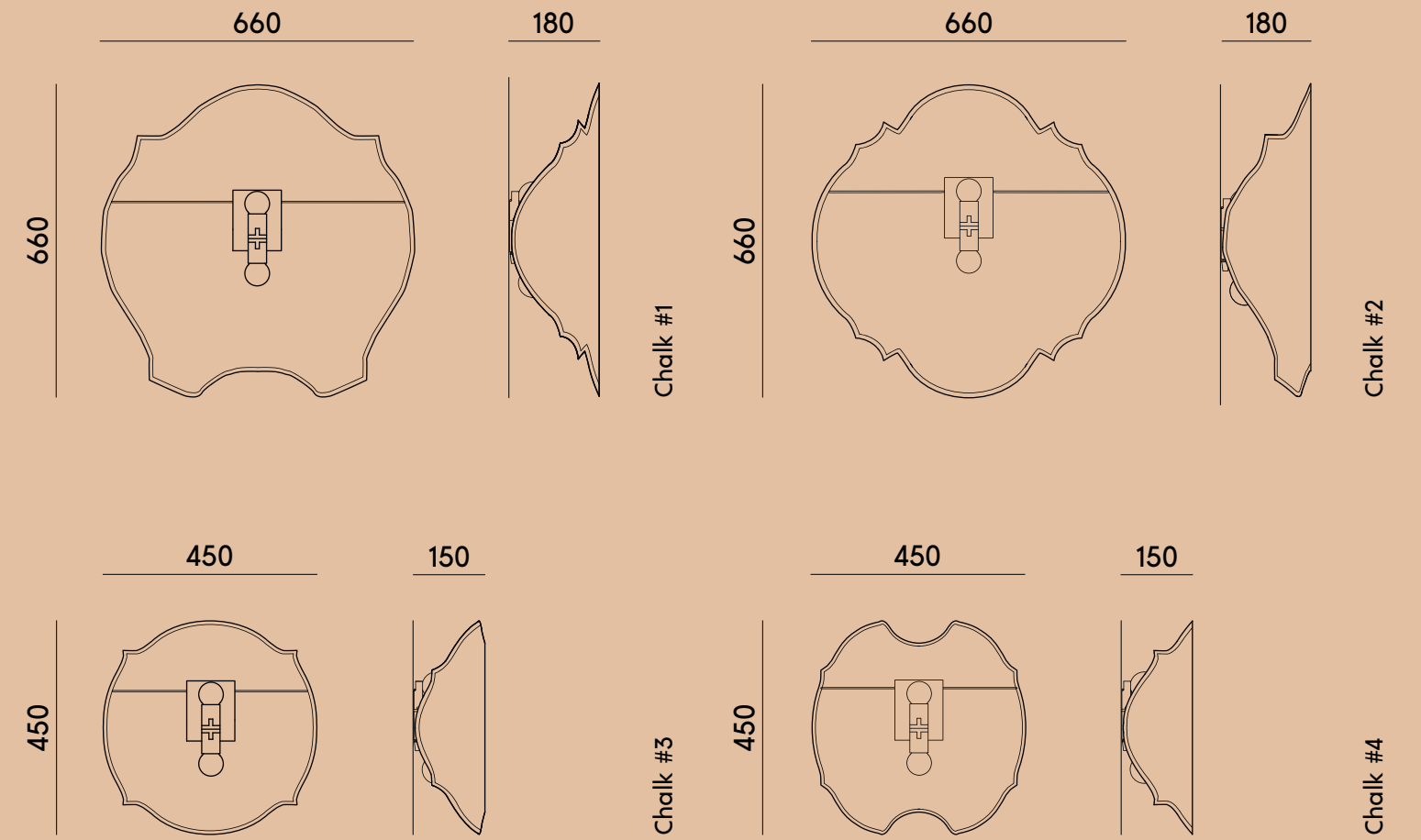

Paralume
Puro lino naturale

Specifiche di illuminazione
Fonte luminosa: 2 x E27 Portalamпада | E26 Portalamпада
Potenza: Max LED 13W
Cablaggio: CE | UL
Compatibile con sistemi dimmerabili

Tutte le dimensioni sono espresse in mm

Lampshade
Pure natural linen

Lighting specifications
Light Source: 2 x E27 Bulb Holder | E26 Bulb Holder
Power: Max LED 13W
Wiring: CE | UL
Compatible with dimmable systems

All dimensions expressed in mm

Chez Joséphine

Chez Joséphine si ispira a due progetti di Adolf Loos: le lampade semicircolari disegnate per l'American Bar a Vienna e le facciate esterne della casa di Joséphine Baker, caratterizzate da strisce orizzontali di marmo bianco. L'unione di questi due riferimenti fortemente evocativi ha dato vita a una lampada a muro eclettica. Caratterizzata da una piastra forata in metallo dorato e da frange blu elettrico, ha due diversi profili: uno a strisce bianche e nere e l'altro in tinta con le frange.

Chez Joséphine is inspired by two different projects of Adolf Loos: the semi-circular lamps designed for the American bar in Vienna and the exterior of Josephine Baker's house, featuring horizontal stripes of black and white marble. The blend of these references gives life to an eclectic wall lamp, boasting a golden-plated perforated iron plate, electric blue fringing and a playful juxtaposition between two different profiles: a black and white striped one and a solid colored one, matching with the fringe.









Chez Joséphine – Left option



Chez Joséphine – Right option

Chez Joséphine

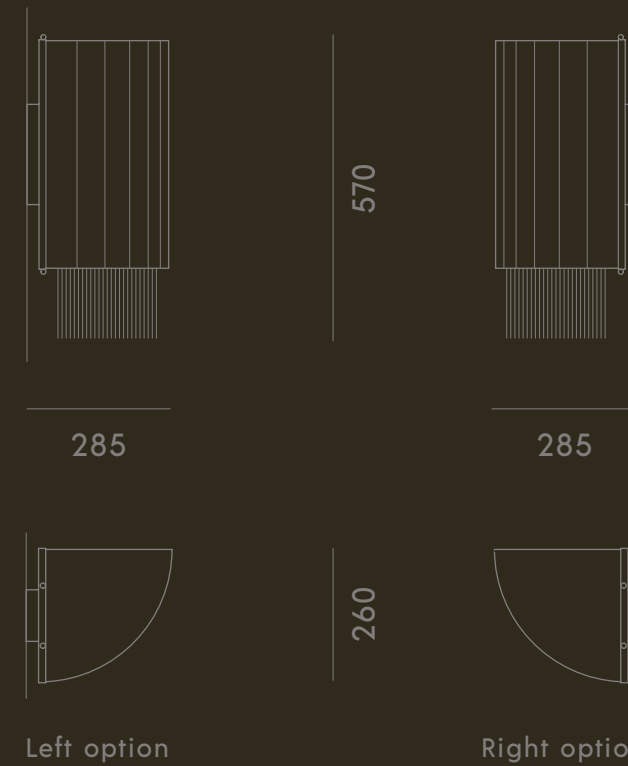

Paralume
Doppio strato di cotone con frange

Struttura
Piastra di ferro dorato perforato

Specifiche di illuminazione
Fonte luminosa: 2 x E27 Portalampada | E26 Portalampada
Potenza: Max LED 13W
Cablaggio: CE | UL
Compatibile con sistemi dimmerabili

Tutte le dimensioni sono espresse in mm

Lampshade
Double-layered cotton fabric with fringes

Structure
Perforated golden iron plate

Lighting specifications
Light Source: 2 x E27 Bulb Holder | E26 Bulb Holder
Power: Max LED 13W
Wiring: CE | UL
Compatible with dimmable systems

All dimensions expressed in mm

Easy Wall

Le applique Easy Wall sono una reinterpretazione delle classiche ventole decorative, rese attuali da colori pastello e rifiniture a contrasto. Belle come pezzo unico o come composizione di diverse forme su una parete. Ogni lampada è fornita di portalampada e cavo in tessuto bordeaux.

The Easy Wall lamp series is a reinterpretation of the classic decorative sconces turning contemporary thanks to pastel colors and contrasting trimmings. Beautiful as a stand alone piece or grouped together as a setup on the wall. Every lamp is supplied with its bulb holder and burgundy fabric cable.







Easy Wall - Gatto Turquoise



Easy Wall - Gatto White



Easy Wall - Ovale Turquoise



Easy Wall - Ovale Tan



Easy Wall - Quadro Tan



Easy Wall - Quadro Pale Yellow



Easy Wall - Cameo White



Easy Wall - Cameo Pale Yellow



Easy Wall - Scudo Tan

Easy Wall

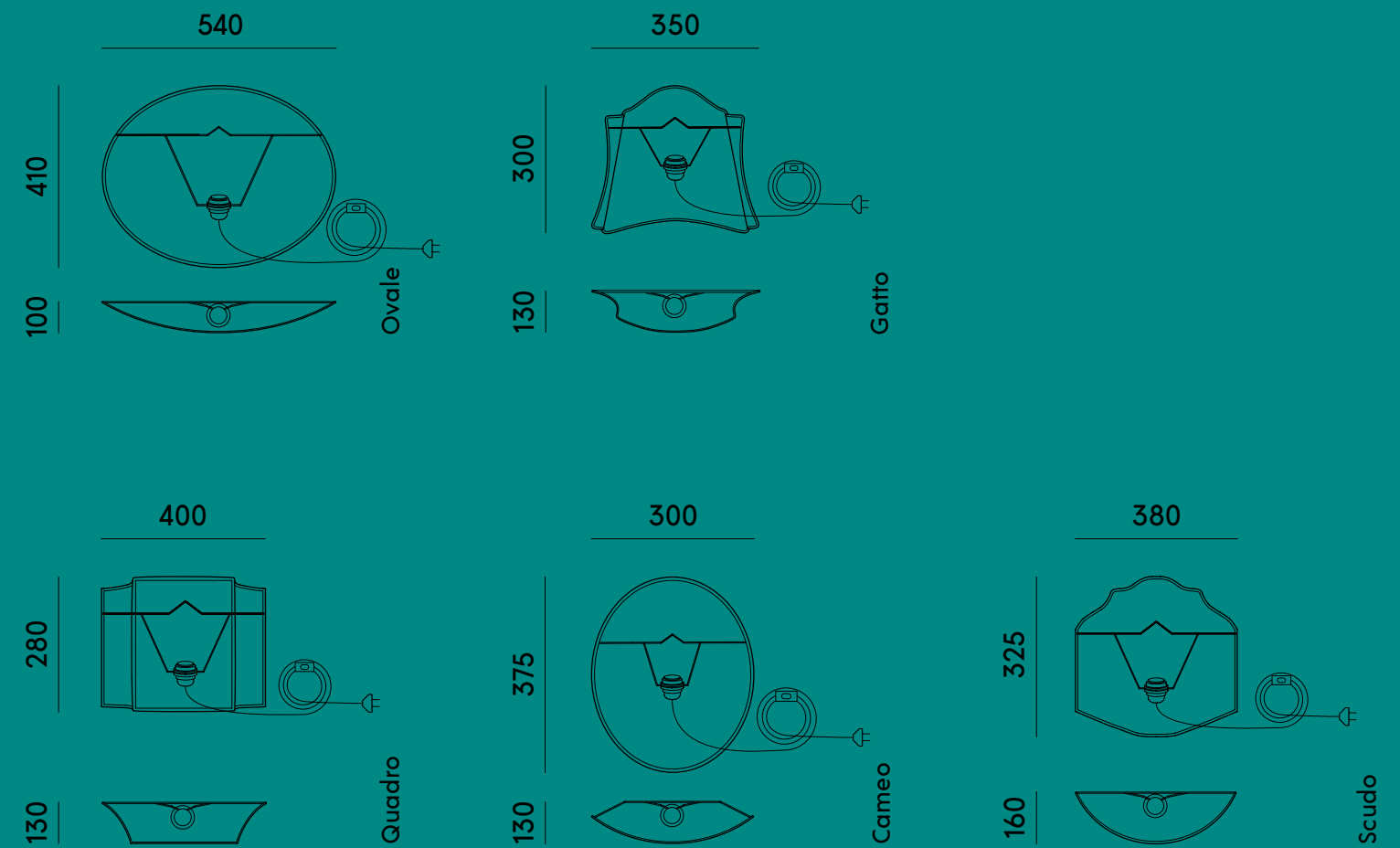

Paralume
Cotone con passamanerie a contrasto

Specifiche di illuminazione
Fonte luminosa: 1 x E27 Portalampada | E26 Portalampada
Potenza: Max LED 13W
Cavo: A treccia rivestito in tessuto bordeaux effetto seta, lungo 2 metri
Spina: Presa Euro - Tipo C - 2 poli | Presa USA - Tipo A - 2 poli
Interruttore: sul cavo
Cablaggio: CE | UL
Non dimmerabile

Tutte le dimensioni sono espresse in mm

Lampshade
Cotton with contrasting trimmings

Lighting specifications
Light source: 1 x E27 Bulb Holder | E26 Bulb Holder
Power: Max LED 13W
Cable: Bordeaux silk alike fabric braided cable, 2 metres long
Plug: Euro Plug - Type C - 2 pins | USA Plug - Type A - 2 pins
Switch: On the cable
Wiring: CE | UL
Not dimmable

All dimensions expressed in mm

Été

Grazie alle sue notevoli dimensioni, l'applique Été è una vera e propria finestra sui ricordi delle estati passate. Lo scatto è una tipica veduta estiva di Pantelleria catturata dallo sguardo della fotografa Giovanna Silva.

Thanks to its considerable size, Été is a real open window on our past summer memories. The picture is a typical summer view of Pantelleria island seen by photographer Giovanna Silva.



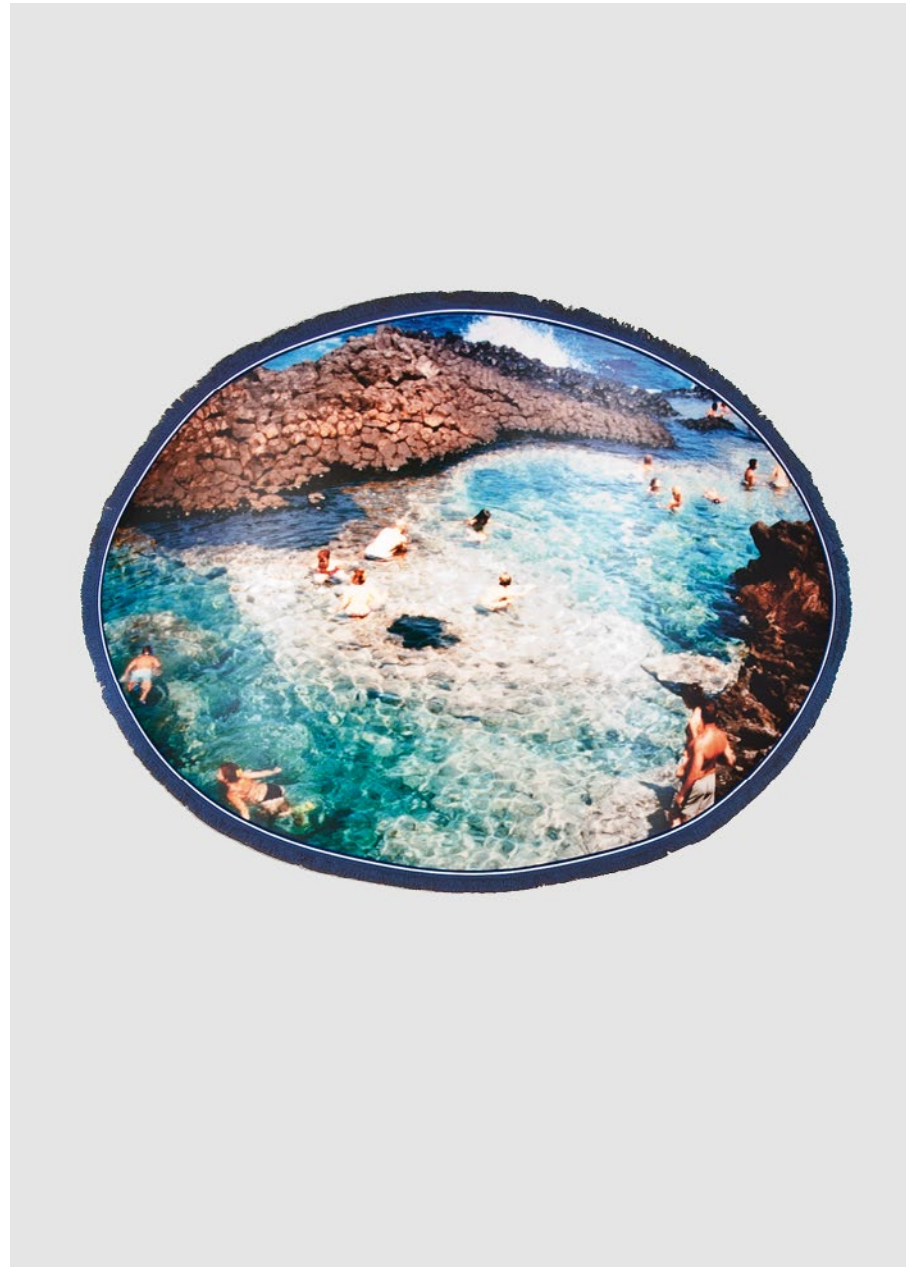

Été

Été

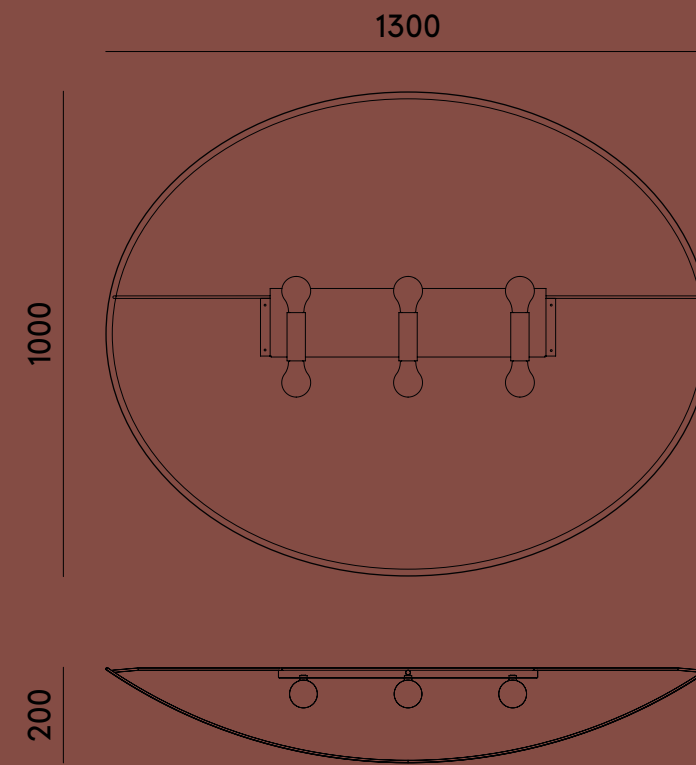

Paralume
Stampa su PVC con passamanerie e frange

Specifiche di illuminazione
Fonte luminosa: 6 x E27 Portalampada | E26 Portalampada
Potenza: Max LED 13W
Cablaggio: CE | UL
Compatibile con sistemi dimmerabili

Tutte le dimensioni sono espresse in mm

Lampshade
Printed PVC with trimmings and fringes

Lighting specifications
Light Source: 6 x E27 Bulb Holder | E26 Bulb Holder
Power: Max LED 13W
Wiring: CE | UL
Compatible with dimmable systems

All dimensions expressed in mm

Flag Wall

La lampada Flag Floor trae ispirazione dall'iconica lampada Servomuto Flag Floor. La forma trae ispirazione da uno scudo africano vestito con cotone naturale plissettato a mano. I colori primari, bianco giallo e rosso utilizzati per i paralumi in cotone ricordano le bandiere segnaletiche, e i dettagli plissettati creano un discreto ed elegante motivo grafico.

Flag wall becomes from the iconic Servomuto Flag Floor. The shape inspired by an African shield is dressed in hand-pleated natural cotton. The primary colors white, yellow, red chosen for the cotton fabric of which is made the screen, reminding us of the code of the signals flags, pleated as to create a rigorous graphic rythm.





Flag Wall 70 - White Single Pleating



Flag Wall 70 - White Double Pleating



Flag Wall 70 - Yellow



Flag Wall 70 - Orange Red



Flag Wall 70 - Medium Grey

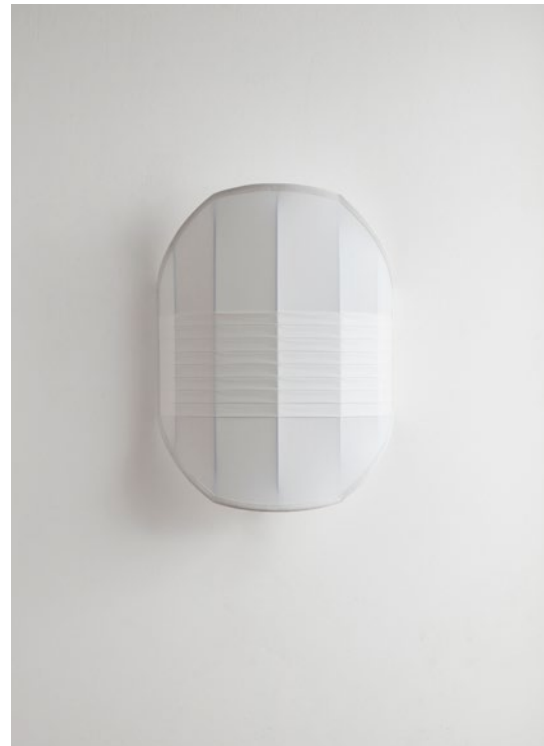

Flag Wall 50 - White



Flag Wall 50 - Yellow



Flag Wall 50 - Orange Red



Flag Wall 50 - Medium Grey

Flag Wall

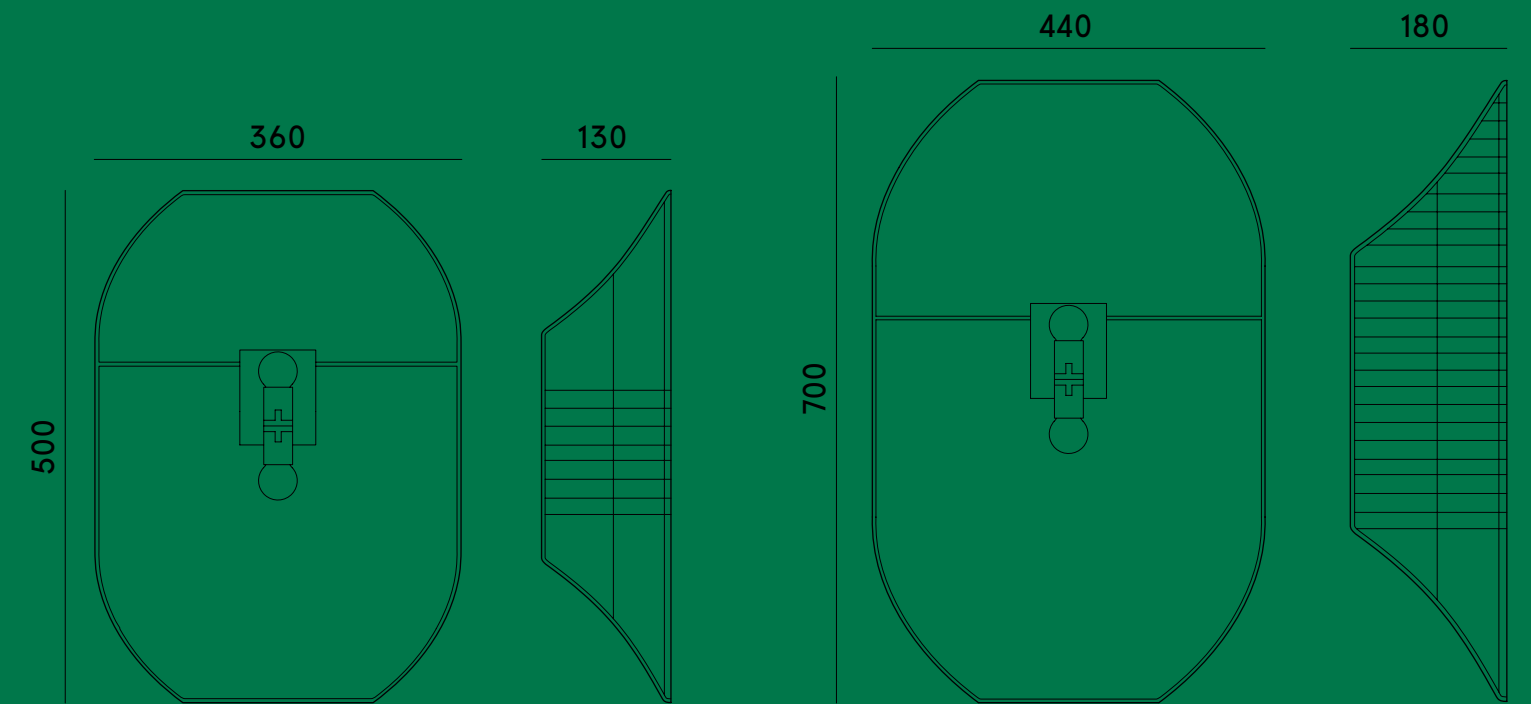

Paralume
Tessuto in cotone plissettato

Specifiche di illuminazione
Fonte luminosa: 2 x E27 Portalampada | E26 Portalampada
Potenza: Max LED 13W
Cablaggio: CE | UL
Compatibile con sistemi dimmerabili

Tutte le dimensioni sono espresse in mm

Lampshade
Pleated cotton fabric

Lighting specifications
Light Source: 2 x E27 Bulb Holder | E26 Bulb Holder
Power: Max LED 13W
Wiring: CE | UL
Compatible with dimmable systems

All dimensions expressed in mm

Guinea Wall

Il ventaglio dell'applique Guinea, realizzato con strati multipli di pongé plissettato e cuciti a mano, richiama la forma di una foglia esotica. La lampada ha una struttura in ottone satinato e un disco in ottone lucido della stessa misura del ventaglio in tessuto, che riflette la luce creando seducenti giochi di colore e una perfetta simmetria di forme.

The fan of our Guinea lamp, with its multiple layers of pleated and sewn pongé fabric, recalls the shape of an exotic leaf. The lamp boasts a satin brass bracket and a solid polished brass disc the same size of the light diffusing fan which reflects the light seductively, resulting in a perfect symmetry of shapes.



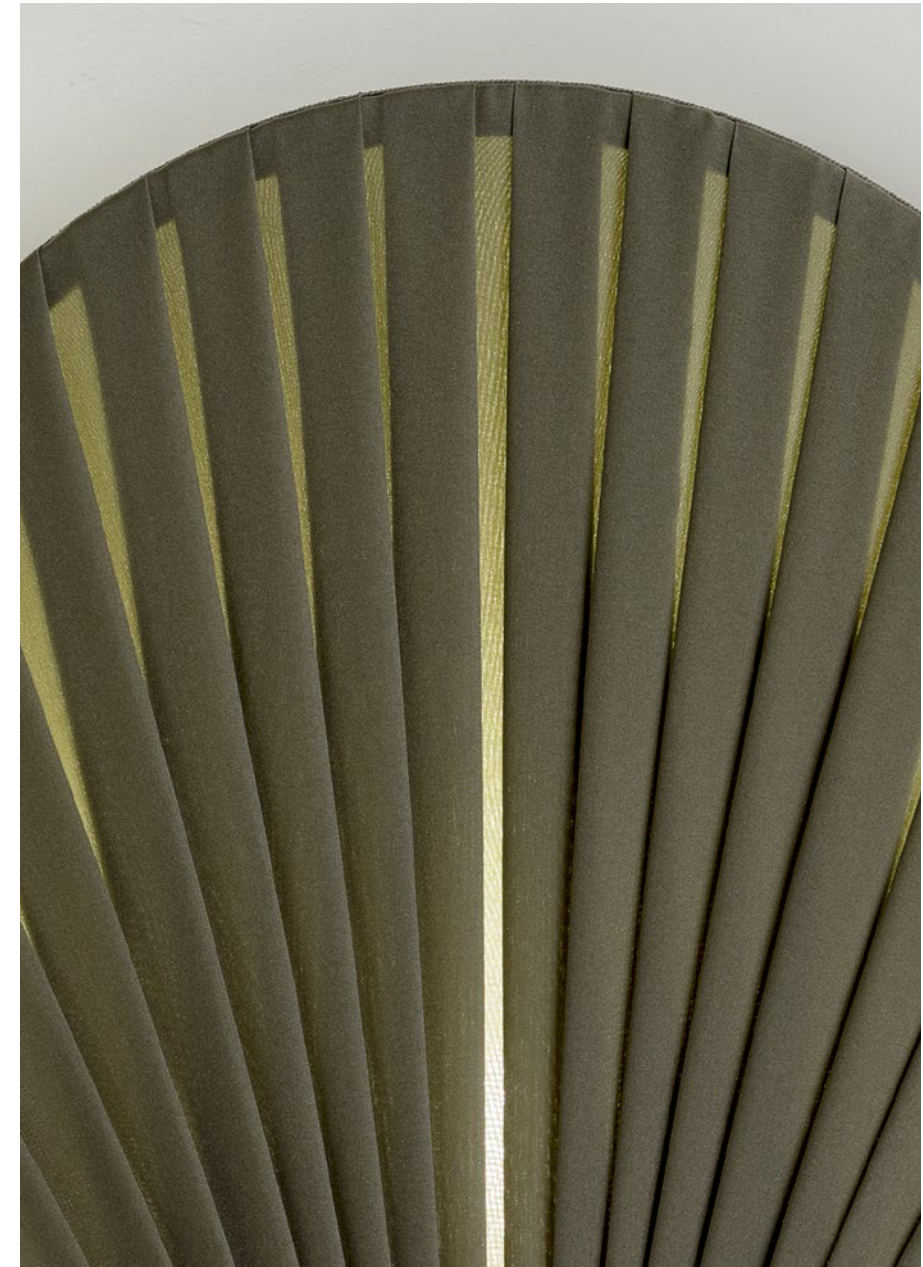



Guinea Wall - Pink



Guinea Wall - Green



Guinea Wall - Brick



Guinea Wall - Azure

Guinea Wall

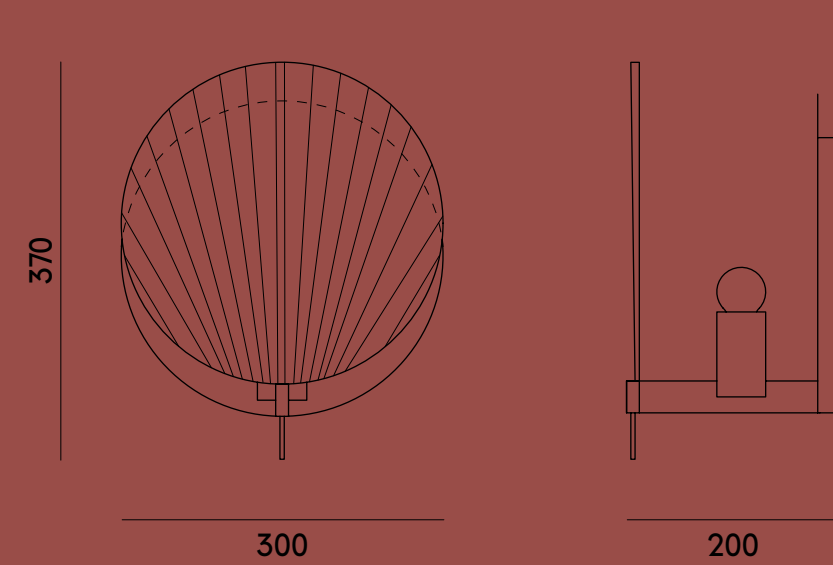

Paralume
Tre strati di pongé plissettato a mano

Struttura
Disco in ottone lucido e braccio in ottone satinato

Specifiche di illuminazione
Fonte luminosa: 1 x E27 Portalampada | E26 Portalampada
Potenza: Max LED 13W
Cablaggio: CE | UL
Compatibile con sistemi dimmerabili

Tutte le dimensioni sono espresse in mm

Lampshade
Triple-layered hand-pleated pongé fabric

Structure
Polished brass disc and satin brass bracket

Lighting specifications
Light Source: 1 x E27 Bulb Holder | E26 Bulb Holder
Power: Max LED 13W
Wiring: CE | UL
Compatible with dimmable systems

All dimensions expressed in mm

Portofino

Portofino, simbolo della dolce vita, località diventata famosa nel corso degli anni Sessanta, è l'elemento di ispirazione di questa collezione. Ombrelloni che invece di schermare la luce servono, questa volta, a diffonderla. Disponibile in motivi a righe, scozzesi o in lino naturale montati su una struttura direzionabile in ottone lucido.

Portofino, the city symbol of the Italian Dolce vita, which became famous during the 1960s, is the inspiration behind this collection. Umbrellas that do diffuse the light, instead of deterring it. Stretched out over adjustable brass structures, the colorful umbrellas come in striped, tartan, or natural linen fabrics.



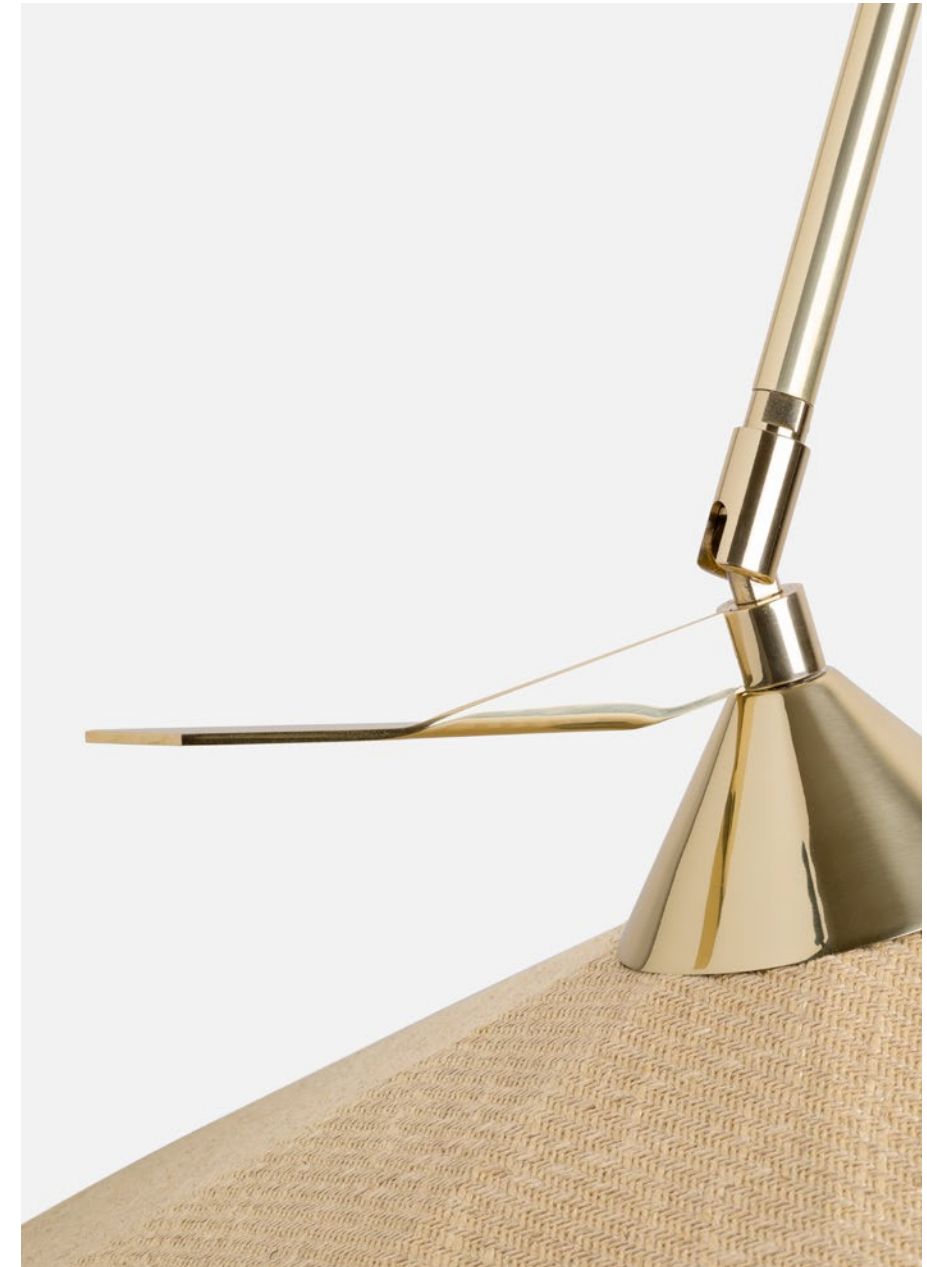



Portofino - Black Stripes



Portofino - Raw Linen



Portofino - Fresco Green



Portofino - Fresco Black

Portofino

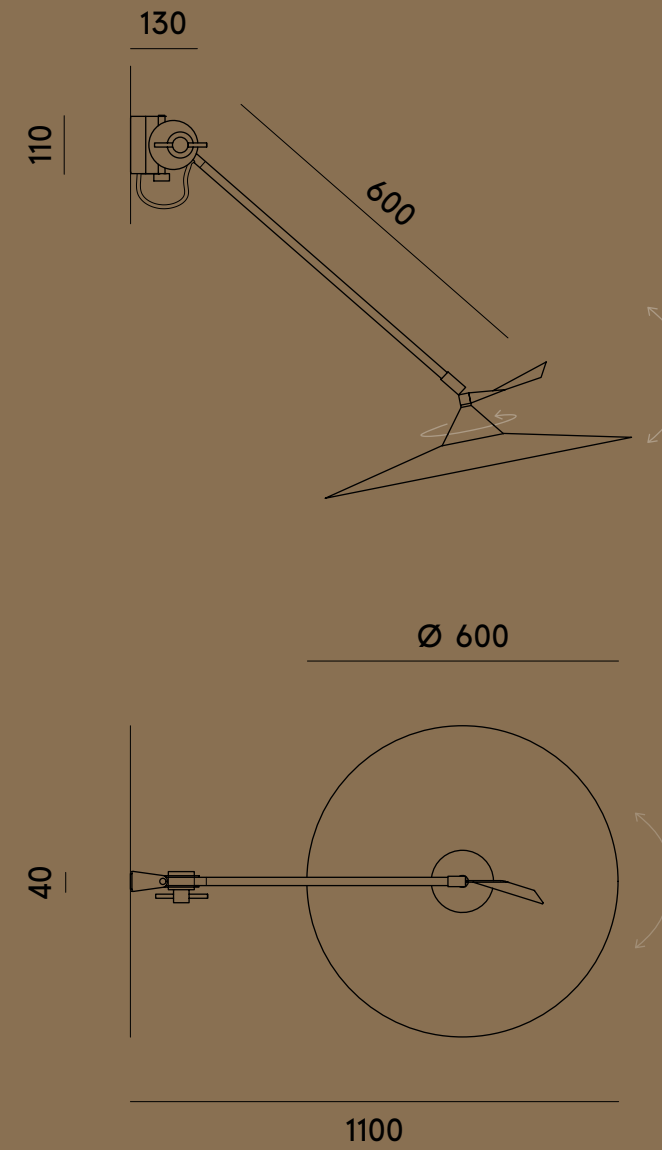

Paralume
Tessuto di Dedar

Struttura
Ottone lucidato

Specifiche di illuminazione
Fonte luminosa: 1 x E27 Portalampada | E26 Portalampada
Potenza: Max LED 13W
Cablaggio: CE | UL
Compatibile con sistemi dimmerabili

Tutte le dimensioni sono espresse in mm

Lampshade
Dedar fabric

Structure
Polished brass

Lighting specifications
Light Source: 1 x E27 Bulb Holder | E26 Bulb holder
Power: Max LED 13W
Wiring: CE | UL
Compatible with dimmable systems

All dimensions expressed in mm

FLOOR

Easy Floor

Le piantane Easy Floor sono caratterizzate da semplici geometrie classiche, reinterpretate da sapienti accostamenti di colore. Il tessuto del paralume in cotone è disponibile in tre diverse tinte unite con rifiniture e frange a contrasto. La base è realizzata in pregiato noce canaletto; lo stelo in ottone trattato, su cui una particolare verniciatura centrale bianca dona leggerezza.

The Easy Floor Lamp is all about simple classic geometry, masterfully revisited through our color combination. The lampshade cotton fabric is presented in block colors with contrasting trimmings and fringing around the bottom rim. The base is made from Canaletto walnut wood; the stem from antique brass with a particular central white varnishing which adds weightlessness to the lamp.







Easy Floor - Tan



Easy Floor - Pale Yellow



Easy Floor - Turquoise

Easy Floor

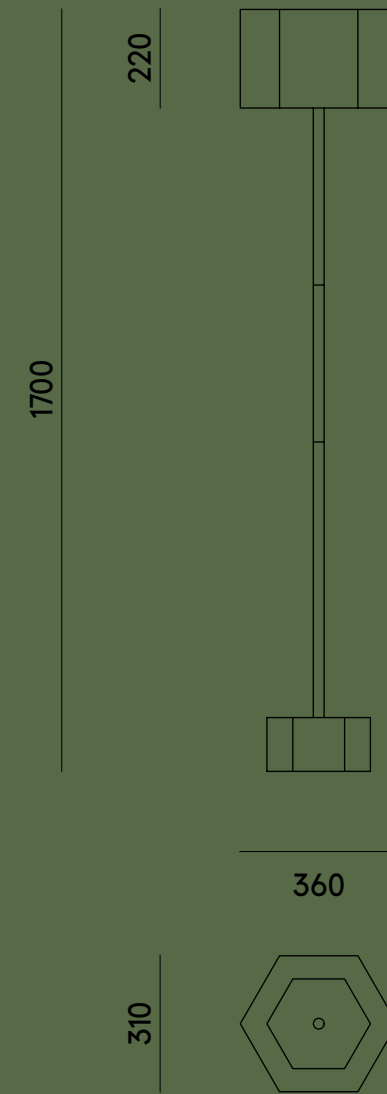

Paralume
Cotone con passamanerie e frangette a contrasto

Lampshade
Cotton with contrasting trimmings and fringes

Struttura
Base esagonale in Noce Canaletto, stelo in ottone brunito

Structure
Hexagonal Canaletto walnut wood, burnished brass stem

Specifiche di illuminazione
Fonte luminosa: 1 x E27 Portalampada | E26 Portalampada
Potenza: Max LED 13W
Cavo: A treccia rivestito in tessuto nero effetto seta, lungo 2 metri
Spina: Presa Euro - Tipo C - 2 poli | Presa USA - Tipo A - 2 poli
Interruttore: sul cavo
Cablaggio: CE | UL
Non dimmerabile

Lighting specifications
Light Source: 1 x E27 Bulb Holder | E26 Bulb Holder
Power: Max LED 13W
Cable: Black silk alike fabric braided cable, 2 metres long
Plug: Euro Plug - Type C - 2 pins | USA Plug - Type A - 2 pins
Switch: On the cable
Wiring: CE | UL
Not dimmable

Tutte le dimensioni sono espresse in mm

All dimensions expressed in mm

Flag Floor

La lampada Flag Floor trae ispirazione da una bandiera e dal gesto di segnare un percorso fuori dai sentieri battuti. Un paralume luminescente leggero, issato su di uno stelo di rovere inserito in un blocco di Ceppo lombardo. I colori primari utilizzati per i paralumi in cotone ricordano le bandiere segnaletiche, e i dettagli plissettati creano un discreto ed elegante motivo grafico.

This lamp takes inspiration from the image of a flag hammered into a stone, as the gesture of marking a place off the beaten track with a visible sign. A luminescent screen, hung from an oak pole, tucked into a piece of circular Ceppo Lombardo stone. The primary colors used for the cotton screens are reminiscent of signal flags and the pleated detailing creates a subtle graphic pattern.









Flag Floor - White Single Pleating



Flag Floor - White Double Pleating



Flag Floor - Yellow



Flag Floor - Orange Red



Flag Floor - Medium Grey



Flag Floor

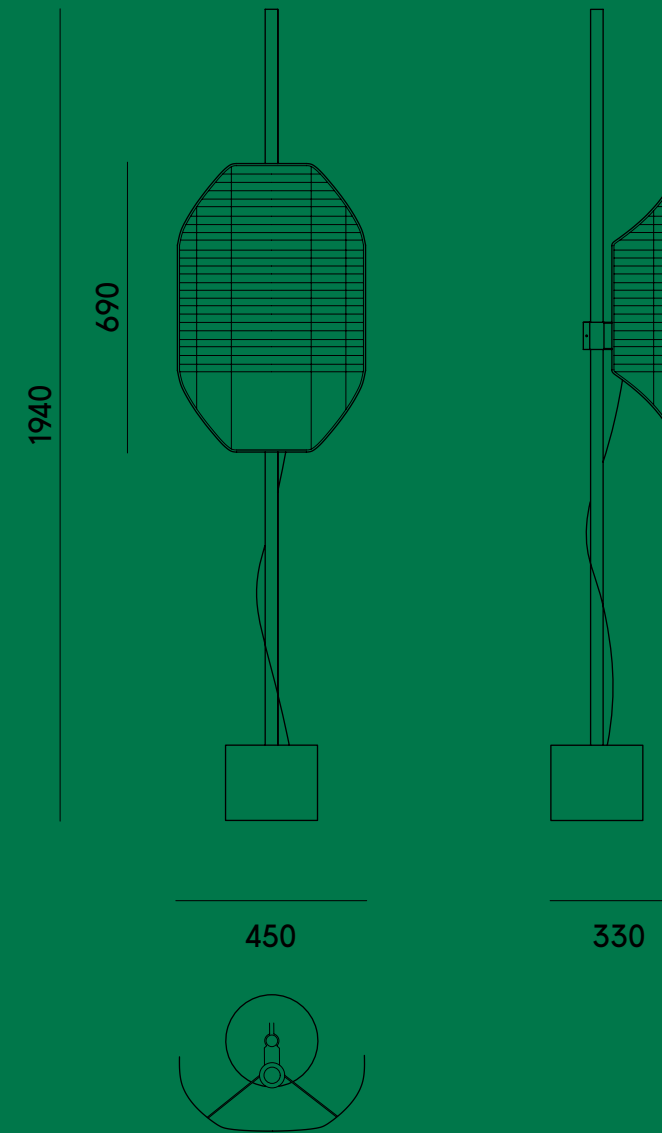

Paralume
Tessuto in cotone plissettato

Lampshade
Pleated cotton fabric

Struttura
Braccio in ferro tropicalizzato, stelo in rovere, base in pietra naturale "Ceppo Lombardo"

Structure
Tropicalized iron bracket, oak wood stem, "Ceppo Lombardo" natural stone base

Specifiche di illuminazione
Fonte luminosa: 1 x E27 Portalampada | E26 Portalampada
Potenza: Max LED 13W
Cavo: Flessibile rivestito in tessuto nero effetto seta, lungo 2,5 metri
Spina: Presa Euro - Tipo C - 2 poli | Presa USA - Tipo A - 2 poli
Interruttore: Cavo CE - sul portalampada | Cavo UL - sul cavo
Cablaggio: CE | UL
Non dimmerabile

Lighting specifications
Light Source: 1 x E27 Bulb Holder | E26 Bulb Holder
Power: Max LED 13W
Cable: Black silk alike fabric flex cable, 2,5 metres long
Plug: Euro Plug - Type C - 2 pins | USA Plug - Type A - 2 pins
Switch: CE wiring - on the bulb holder | UL wiring - on the cable
Wiring: CE | UL
Not dimmable

Tutte le dimensioni sono espresse in mm

All dimensions expressed in mm

Giardino Floor

Piantana che amplia la famiglia GIARDINO (già a catalogo con le omonime sospensioni) presentata nelle tre tradizionali varianti avorio/rosa, bianco/nero, verde/nero più una nuova con motivo a foglie. Ha il paralume realizzato in rattan e tessuto con passamaneria a contrasto, uno stelo in rovere e una base in cemento. Il design della piantana trae ispirazione dagli ombrelloni da esterno, con volumi e forme che ricordano gli arredi per esterni, integrandoli perfettamente negli spazi interni.

An extension of the GIARDINO family, the GIARDINO FLOOR comes in three traditional variants: ivory/pink, white/black, and green/black plus a new one with leaf motif. With a lampshade crafted from rattan and fabric, contrasting trimmings, an oak stem, and a concrete base, its design draws inspiration from outdoor umbrellas, seamlessly integrating outdoor furniture elements into interior spaces.







Giardino Floor - #1 Black and White



Giardino Floor - #2 Black and Green



Giardino Floor - #3 Pink and White



Giardino Floor - #4 Sand

Giardino Floor

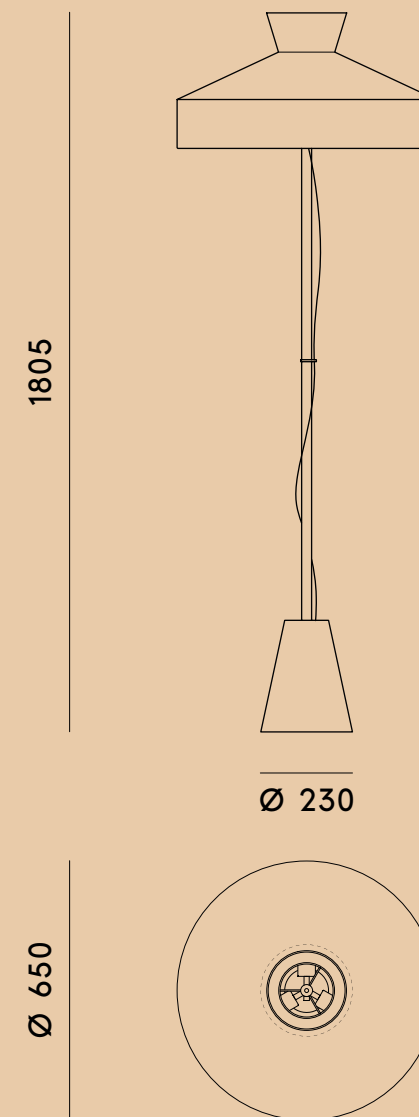

Paralume
Rattan, tessuti jacquard

Struttura
Base in cemento, stelo in rovere e ferro verniciato nero opaco

Specifiche di illuminazione
Fonte luminosa: 3 x E27 Portalampada | E26 Portalampada
Potenza: Max LED 13W
Cavo: Flessibile rivestito in tessuto nero effetto seta, lungo 2 metri
Spina: Presa Euro - Tipo C - 2 poli | Presa USA - Tipo A - 2 poli
Interruttore: dimmer sul cavo
Cablaggio: CE | UL

Tutte le dimensioni sono espresse in mm

Lampshade
Rattan, jacquard fabric

Structure
Cement base, oak wood stem and matt black painted iron

Lighting specifications
Light Source: 3 x E27 Bulb Holder | E26 Bulb Holder
Power: Max LED 13W
Cable: Black silk alike fabric flex cable, 2 metres long
Plug: Euro Plug - Type C - 2 pins | USA Plug - Type A - 2 pins
Switch: Dimmer on the cable
Wiring: CE | UL

All dimensions expressed in mm

Haute Couture

La lampada Haute Couture rende omaggio allo spirito visionario dell'alta moda parigina. Interamente realizzata a mano come un abito sartoriale, si ancora al pavimento con una base esagonale in frassino, e si apre in un coloratissimo vestito fatto da impalpabili strisce di tessuto pongé bicolore che lasciano filtrare la luce.

The Haute Couture lamp pays homage to the visionary spirit of Parisian Haute Couture. In a joyful soar from the ground to the ceiling, this tailor-made lamp is anchored to the floor with its hexagonal ash base, fiercely opening up in a colorful gown made of weightless pongé fabric strips that let the light seep in.







Haute Couture - Blue/Lilac



Haute Couture - Brick/Pale Yellow



Haute Couture - Lilac/Ochre



Haute Couture - Blue/Brick



Haute Couture - Ochre/Green



Haute Couture - Blue/Pale Yellow



Haute Couture - Brick/Green

Haute Couture

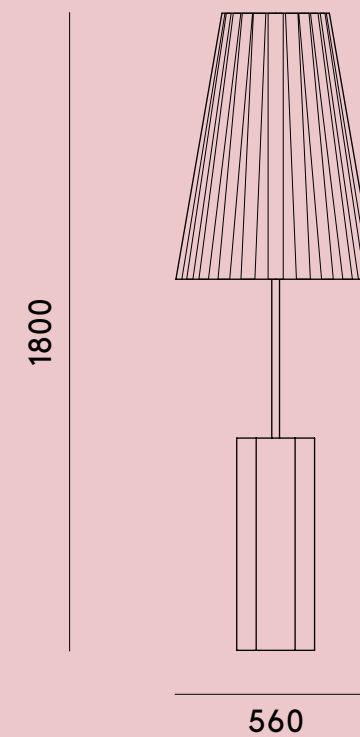
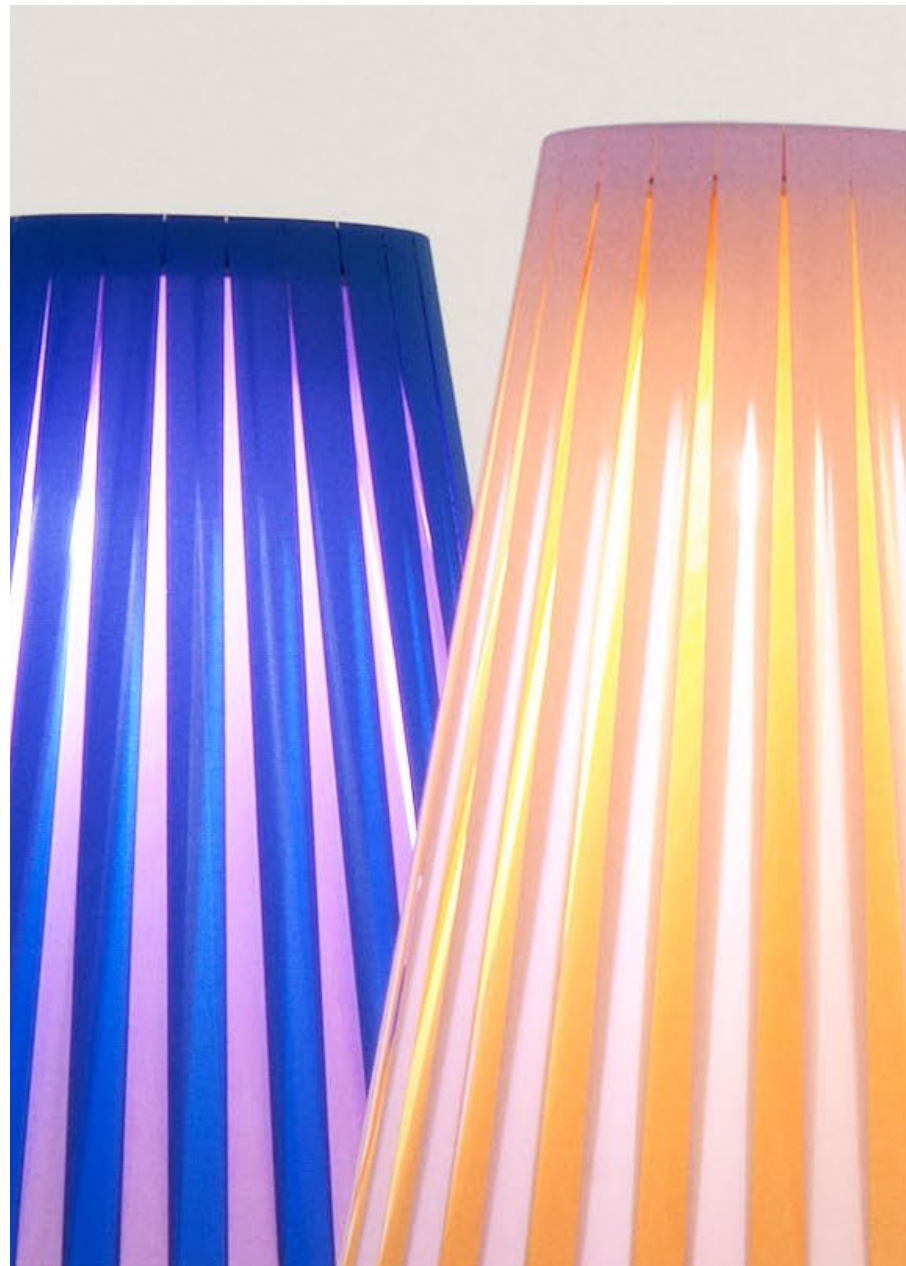

Paralume
Fasce in pongé bicolore sovrapposte rifinite con passamaneria

Struttura
Base esagonale e stelo in frassino

Specifiche di illuminazione
Fonte luminosa: 3 x E27 Portalampada | E26 Portalampada
Potenza: Max LED 13W
Cavo: A treccia rivestito in tessuto nero effetto seta, lungo 2 metri
Spina: Presa Euro - Tipo C - 2 poli | Presa USA - Tipo A - 2 poli
Interruttore: sul cavo
Cablaggio: CE | UL
Non dimmerabile

Tutte le dimensioni sono espresse in mm

Lampshade
Two-tone overlapped large scale pongé ribbons refined with trimmings

Structure
Hexagonal ash wood base and stem

Lighting specifications
Light Source: 3 x E27 Bulb Holder | E26 Bulb Holder
Power: Max LED 13W
Cable: Black silk alike fabric braided cable, 2 metres long
Plug: Euro Plug - Type C - 2 pins | USA Plug - Type A - 2 pins
Switch: On the cable
Wiring: CE | UL
Not dimmable

All dimensions expressed in mm

TABLE

Huf

Huf, una lampada audace e giocosa creata dal designer austriaco Arthur Arbesser. Il nome Huf richiama la parola tedesca per "zoccolo di cavallo", un riferimento appropriato alla base a forma di U della lampada. Huf è un equilibrio tra geometria e fascino. La sua solida base in cemento, modellata come un ferro di cavallo, ancora il design con curve pulite ma accoglienti. Il paralume riflette questa silhouette arcuata, lasciando spazio a colori vivaci e grafiche dinamiche. La lampada è disponibile in due dimensioni, offrendo versatilità per diversi ambienti. Che sia posizionata accanto a una libreria o su una consolle, Huf interagisce con l'ambiente circostante con naturalezza - aggiungendo carattere senza mai sovrastare la stanza. È un design minimale, ma fortemente iconico.

Huf, a bold and playful lamp created by Austrian designer Arthur Arbesser. The name Huf nods to the German word for "horse's hoof", a fitting reference to the lamp's U-shaped base. Huf is a balancing act of geometry and charm. Its solid concrete base, shaped like a horseshoe, anchors the design with clean yet welcoming curves. The lampshade mirrors this arched silhouette, leaving room for bold colors and dynamic graphics. The lamp comes in two sizes offering versatility across different spaces. Whether placed beside a bookcase or perched on a console table, Huf interacts effortlessly with its surroundings - adding character without overpowering the room. It's a design that doesn't shout but speaks volumes.







Huf - Aquarelle



Huf - Lozenge



Huf - Butter



Huf - Light blue



Huf - Rainbow



Huf - Mauve



Huf - Orange



Huf

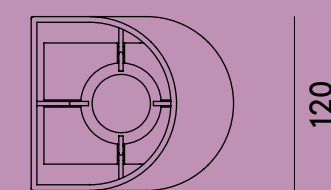
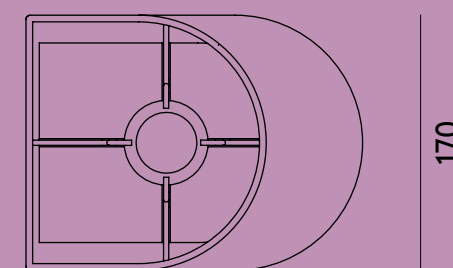
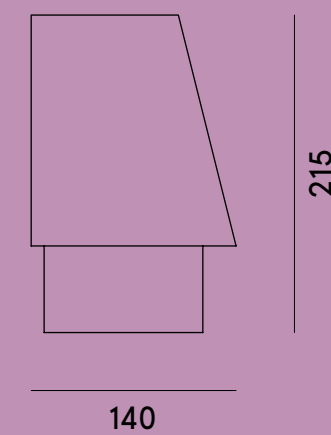
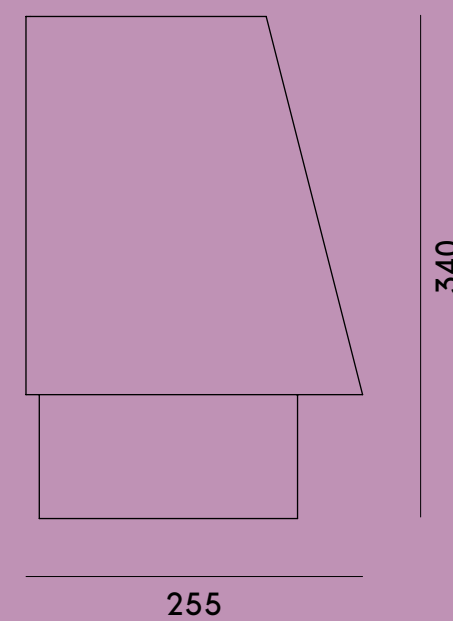

Paralume:
Cotone
Struttura:
Cemento, ferro cromato

Lampshade:
Cotton fabric
Structure:
Cement, chromed iron

Specifiche di illuminazione:
Fonte luminosa: 1 x E27 Portalampada | E26 Portalampada
Cavo: Flessibile rivestito in tessuto nero effetto seta, lungo 2 metri
Spina: Presa Euro - Tipo C - 2 poli | Presa USA - Tipo A - 2 poli
Interruttore: sul cavo
Cablaggio: CE | UL

Lighting specifications:
Light Source: 1 x E27 Bulb Holder | E26 Bulb Holder
Cable: Black silk alike fabric cable, 2 metres long
Plug: Euro Plug - Type C - 2 pins | USA Plug - Type A - 2 pins
Switch: On the cable
Wiring: CE | UL

Tutte le dimensioni sono espresse in mm

All dimensions expressed in mm

Cement

La lampada Cement trae ispirazione dalle ceramiche e dalle sinuose forme realizzate al tornio. La silhouette semplice e lineare della base della lampada è il risultato di un calco in cemento realizzato da un vecchio isolatore elettrico in ceramica, gelosamente custodito nell'archivio SERVOMUTO. La finitura a cera del calcestruzzo fa sì che il corpo della lampada risulti al tatto liscio e vellutato. Accessori in rame e paralume in puro lino completano la lampada. Disponibile in sette colori pastello più in una versione speciale in rattan.

The Cement lamp is inspired by ceramics and the organic forms created during pottery wheel throwing and playing. The final silhouette is then created with cement moulded in a silicon cast produced using an old porcelain electrical insulator from the SERVOMUTO archives. The concrete has a wax finish and a silky touch. The light bulb fixture and the visible stem are made from copper and the texture of the pure linen or rattan lampshade beautifully complements with the cement base. Available in seven pastel color as well as a special version in rattan.



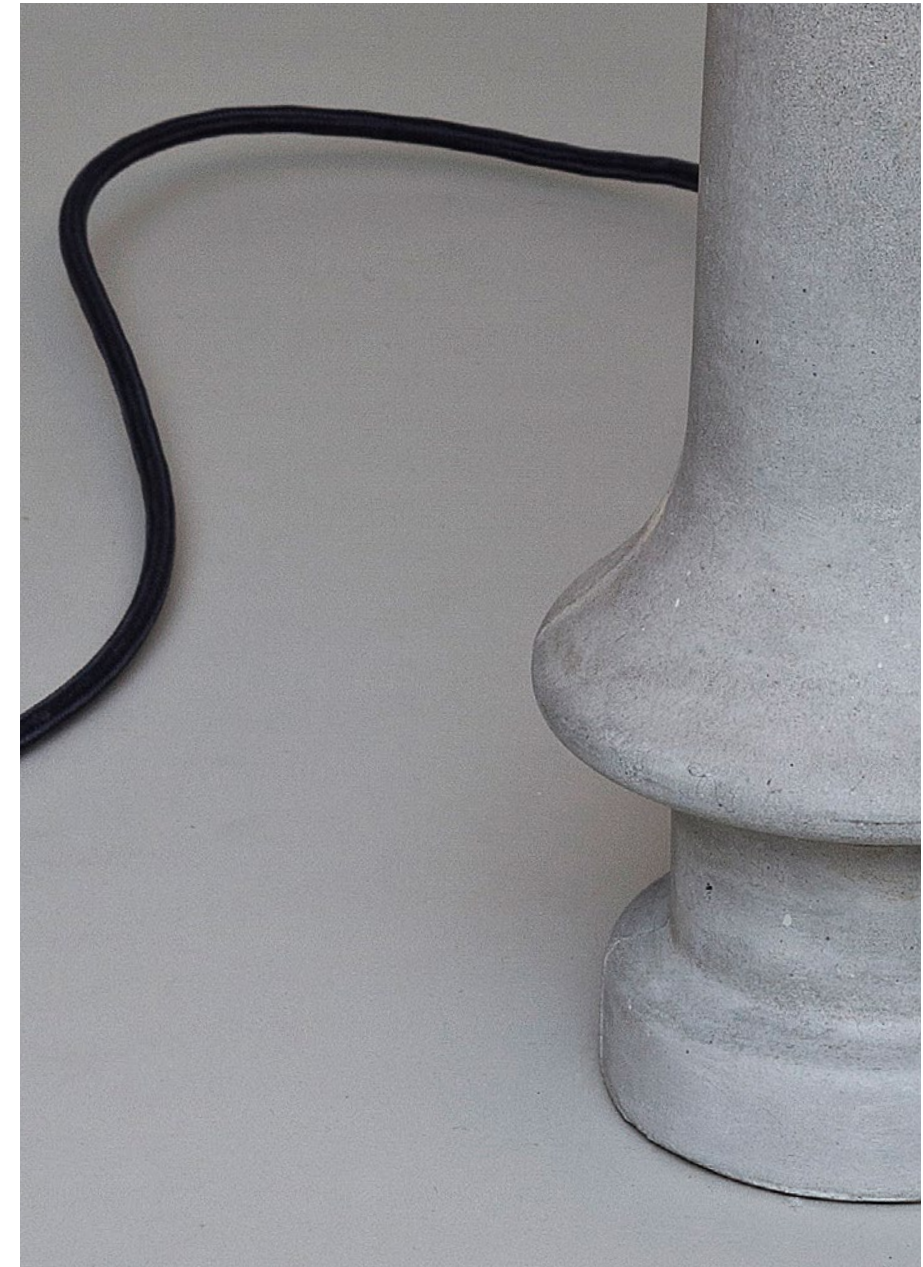



Cement - Grey



Cement - White



Cement - Yellow



Cement - Bordeaux



Cement - Light Blue



Cement - Turquoise



Cement - Rattan



Cement

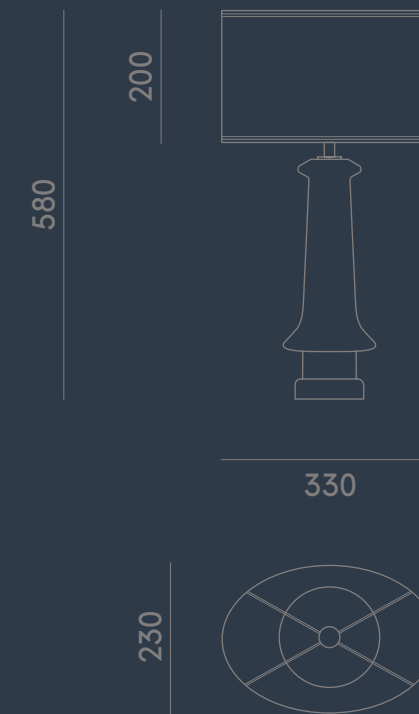

Paralume
Puro lino naturale / Rattan

Lampshade
Pure natural linen / Rattan

Struttura
Cemento cerato grigio chiaro, dettagli in rame

Structure
Light grey waxed cast cement, copper details

Specifiche di illuminazione
Fonte luminosa: 1 x E27 Portalampada | E26 Portalampada
Potenza: Max LED 13W
Cavo: Flessibile rivestito in tessuto nero effetto seta, lungo 2 metri
Spina: Presa Euro - Tipo C - 2 poli | Presa USA - Tipo A - 2 poli
Interruttore: sul cavo
Cablaggio: CE | UL
Non dimmerabile

Lighting specifications
Light Source: 1 x E27 Bulb Holder | E26 Bulb Holder
Power: Max LED 13W
Cable: Black silk alike fabric flex cable, 2 metres long
Plug: Euro Plug - Type C - 2 pins | USA Plug - Type A - 2 pins
Switch: On the cable
Wiring: CE | UL
Not dimmable

Tutte le dimensioni sono espresse in mm

All dimensions expressed in mm

Easy Table

Le lampade Easy Table sono caratterizzate da semplici geometrie classiche, reinterpretate da sapienti accostamenti di colore. Il tessuto del paralume in cotone è disponibile in tre diverse tinte unite con rifiniture a contrasto. La base è realizzata in pregiato noce canaletto; lo stelo in ottone trattato.

The Easy Table lamp is all about simple classic geometry, masterfully revisited through our color combinations. The lampshade cotton fabric is presented in block colors with contrasting trimmings. The base is made of Canaletto walnut wood, and the stem of treated brass.







Easy Table - Pale Yellow



Easy Table - Tan



Easy Table - Turquoise

Easy Table

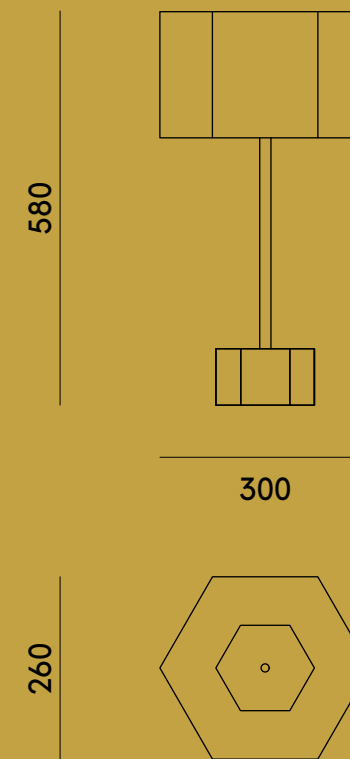

Paralume
Cotone con passamanerie a contrasto

Lampshade
Cotton with contrasting trimmings

Struttura
Base esagonale in Noce Canaletto, stelo in ottone brunito

Structure
Hexagonal Canaletto walnut wood, burnished brass stem

Specifiche di illuminazione
Fonte luminosa: 1 x E27 Portalampada | E26 Portalampada
Potenza: Max LED 13W
Cavo: A treccia rivestito in tessuto nero effetto seta, lungo 2 metri
Spina: Presa Euro - Tipo C - 2 poli | Presa USA - Tipo A - 2 poli
Interruttore: sul cavo
Cablaggio: CE | UL
Non dimmerabile

Lighting specifications
Fonte luminosa: 1 x E27 Bulb Holder | E26 Bulb Holder
Power: Max LED 13W
Cable: Black silk alike fabric braided cable, 2 metres long
Plug: Euro Plug - Type C - 2 pins | USA Plug - Type A - 2 pins
Switch: On the cable
Wiring: CE | UL
Not dimmable

Tutte le dimensioni sono espresse in mm

All dimensions expressed in mm

Otto Table

È la versione da tavolo delle omonime sospensioni, presentate durante EuroLuce 2023, che amplia la linea della famiglia OTTO. Ha una base conica realizzata in massello di mogano e i paralumi disponibili nelle varianti con tessuti Rubelli, come per le sospensioni, arricchite da quattro nuovi tessuti Dedar: tre in "A Perfect Flower" (nei colori del blu elettrico, giallo lime, rosa) e una in "Tweedledee" (color sale e pepe).

Derived from the suspensions showcased at EuroLuce 2023, the OTTO TABLE expands the OTTO collection. Featuring a conical base crafted from solid mahogany, the lampshades are available in Rubelli fabrics, enriched with four new Dedar fabrics: three in "A Perfect Flower" (electric blue, lime yellow, pink) and one in "Tweedledee" (salt and pepper color).





204

Servomuto



Collection

205



Otto Table - Brown



Otto Table - Green



Otto Table - Ecrù



Otto Table - Cobalt



Otto Table - Pink



Otto Table - Azure



Otto Table - Yellow



Otto Table - Tender Rose



Otto Table - Salt and Pepper

Otto Table

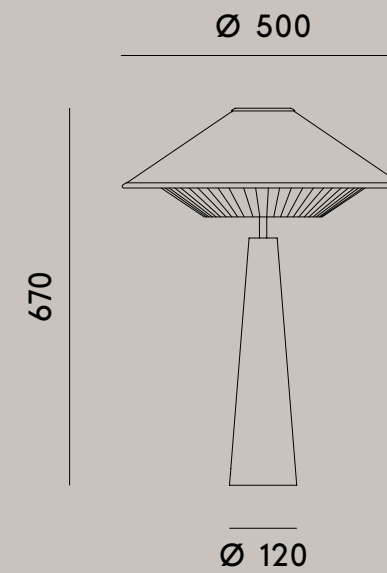

Paralume superiore
Tessuto di Rubelli / Dedar

Paralume inferiore
Fasce in pongé plissettato

Struttura
Base in mogano, dettagli in ottone

Specifiche di illuminazione
Fonte luminosa: 1 x E27 Portalampada | E26 Portalampada
Potenza: Max LED 13W
Cavo: A treccia rivestito in tessuto nero effetto seta, lungo 2 metri
Spina: Presa Euro - Tipo C - 2 poli | Presa USA - Tipo A - 2 poli
Interruttore: sul cavo
Cablaggio: CE | UL
Non dimmerabile

Tutte le dimensioni sono espresse in mm

Upper Lampshade
Rubelli / Dedar fabric

Lower Lampshade
Pleated pongé bends

Structure
Mahogany base, brass-plated iron details

Lighting specifications
Light Source: 1 x E27 Bulb Holder | E26 Bulb Holder
Power: Max LED 13W
Cable: Black silk alike fabric braided cable, 2 metres long
Plug: Euro Plug - Type C - 2 pins | USA Plug - Type A - 2 pins
Switch: On the cable
Wiring: CE | UL
Not dimmable

All dimensions expressed in mm

SPECIAL EDITION

Alghero

I paesaggi della suggestiva campagna sarda e la sua atmosfera serena sono la fonte d'ispirazione per le lampade "Alghero". Questa collezione incarna l'essenza di Servomuto, sposando l'attenzione ai dettagli con l'uso dei pregiati tessuti in cotone, i cui vivaci motivi a strisce, si fondono elegantemente con qualsiasi stile d'arredamento, aggiungendo un tocco raffinato sia agli interni moderni, sia a quelli più tradizionali. Ogni lampada della collezione "Alghero" è realizzata con maestria per garantire non solo una bellezza senza tempo, ma anche una funzionalità impeccabile. Che si tratti di illuminare un angolo lettura intimo o di creare un'atmosfera accogliente nella zona living, le lampade "Alghero" trasformano lo spazio in pura eleganza e raffinatezza.

The "Alghero" lamps are inspired by the calm landscapes of the Sardinian countryside, offering a serene atmosphere to its surroundings. This exquisite collection is crafted with great attention to detail and embellished with the classic stripe pattern of refined cotton fabric. The combination of colors spreads sophistication to any space, effortlessly complementing modern and traditional decor styles. Each lamp in the "Alghero" collection is carefully prepared to ensure beauty and functionality, from the elegant lamp holder to the durable fabric cable. Whether illuminating a cozy reading nook or creating a welcoming atmosphere in the living space, the "Alghero" collection offers timeless elegance and unparalleled quality.



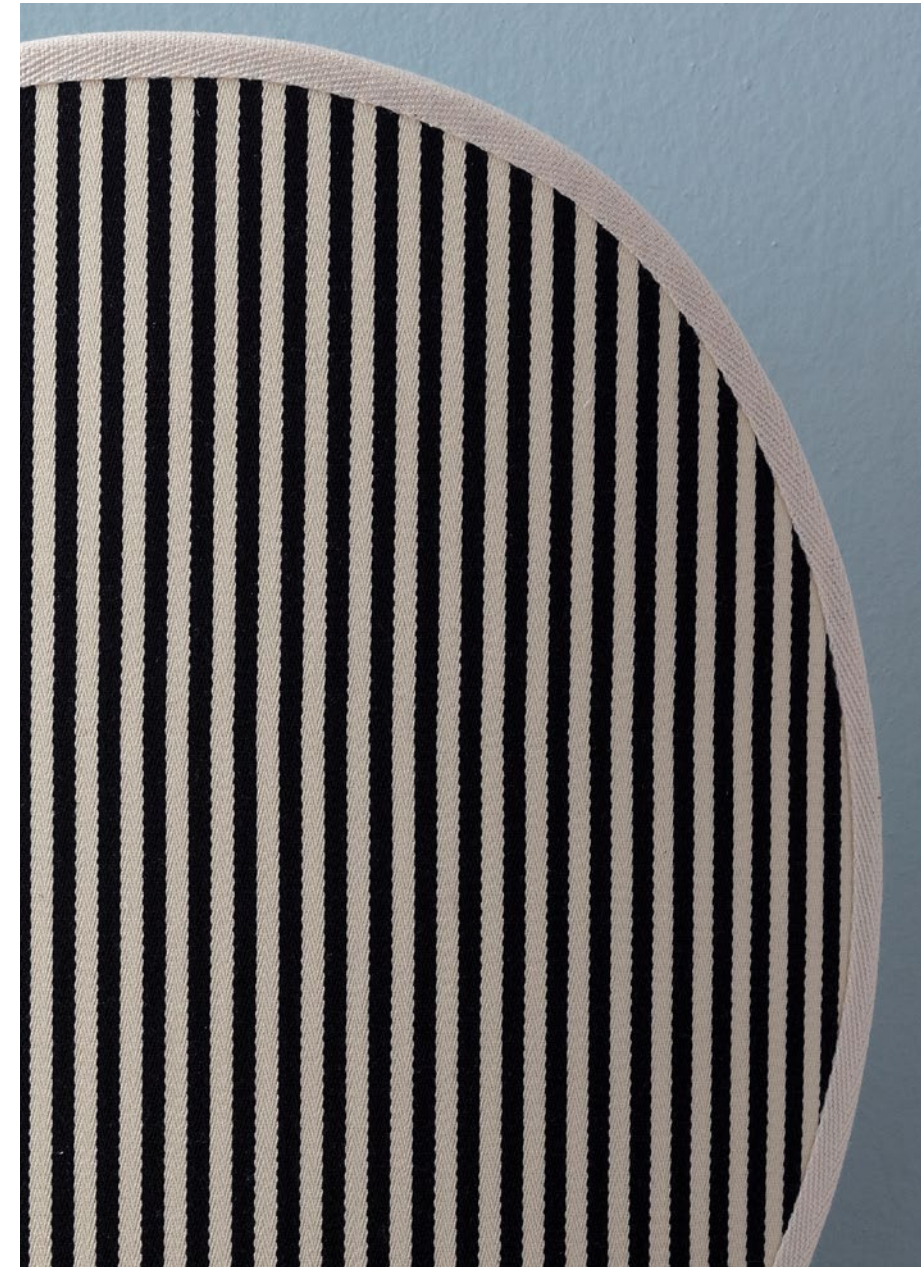



Alghero - Butterfly Black and White



Alghero - Cameo Black and White

Alghero

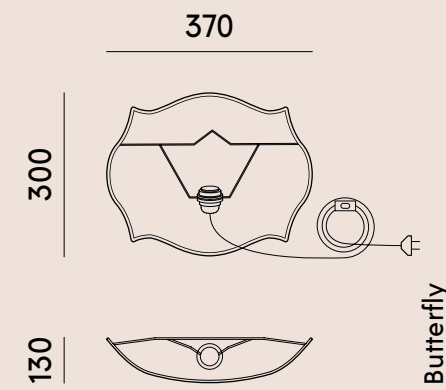

Butterfly

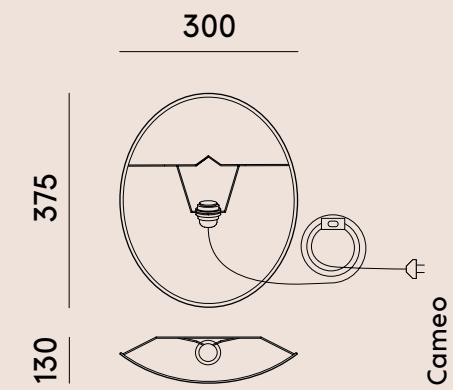

Cameo

Paralume
Tessuto in cotone

Specifiche di illuminazione
Fonte luminosa: 1 x E27 Portalampada | E26 Portalampada
Potenza: Max LED 13W
Cavo: A treccia rivestito in tessuto bordeaux effetto seta, lungo 2 metri
Spina: Presa Euro - Tipo C - 2 poli | Presa USA - Tipo A - 2 poli
Interruttore: sul cavo
Cablaggio: CE | UL
Non dimmerabile

Tutte le dimensioni sono espresse in mm

Lampshade
Cotton fabric

Lighting specifications
Light source: 1 x E27 Bulb Holder | E26 Bulb Holder
Power: Max LED 13W
Cable: Bordeaux silk alike fabric braided cable, 2 metres long
Plug: Euro Plug - Type C - 2 pins | USA Plug - Type A - 2 pins
Switch: On the cable
Wiring: CE | UL
Not dimmable

All dimensions expressed in mm

Ambarabà

Ambarabà è l'accattivante edizione speciale di applique Servomuto, realizzata con meticolosa attenzione ai dettagli, pronta a ridefinire l'atmosfera di qualsiasi spazio. La serie trae ispirazione dall'incantevole mondo della natura, con paralumi realizzati con carta da parati "Foglie e Civette" di Fornasetti, raffiguranti gufi nel loro habitat naturale in una tavolozza di sfumature di verde. Questa immagine aggiunge un tocco etereo alle lampade, portando l'aria aperta nelle abitazioni. Le forme utilizzate per le applique Ambarabà sono le classiche "Butterfly" e "Lanterna" di Servomuto che danno vita a un design senza tempo e contemporaneo che si integra perfettamente in diversi stili di interni.

Ambarabà is Servomuto's captivating special edition of wall lamps, crafted with meticulous attention to detail, poised to redefine the ambiance of any space. The series draws inspiration from the enchanting world of nature, featuring lampshades made of exquisite Fornasetti's "Foglie e Civette" wallpaper, depicting owls in their natural habitat in a palette of rich greens. This choice of imagery adds a touch of the ethereal to the lamps, bringing a sense of the outdoors into the living space. The distinctive shapes of the Ambarabà lamps are a fusion of elements from Servomuto's esteemed "Butterfly" and "Lanterna" collections, resulting in a timeless and contemporary design that seamlessly integrates into diverse interior styles.







Ambarabà - Butterfly



Ambarabà - Lanterna

Ambarabà

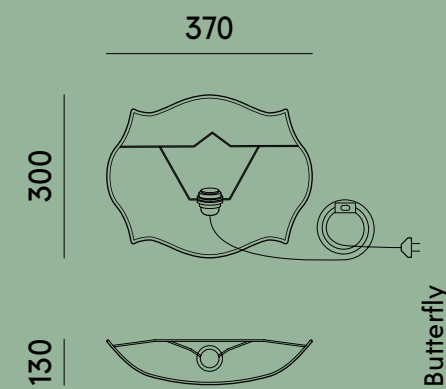

Paralume
Carta da parati Foglie e Civette di Fornasetti

Specifiche di illuminazione
Fonte luminosa: 1 x E27 Portalampada | E26 Portalampada
Potenza: Max LED 13W
Cavo: A treccia rivestito in tessuto bordeaux effetto seta, lungo 2 metri
Spina: Presa Euro - Tipo C - 2 poli | Presa USA - Tipo A - 2 poli
Interruttore: sul cavo
Cablaggio: CE | UL
Non dimmerabile

Tutte le dimensioni sono espresse in mm

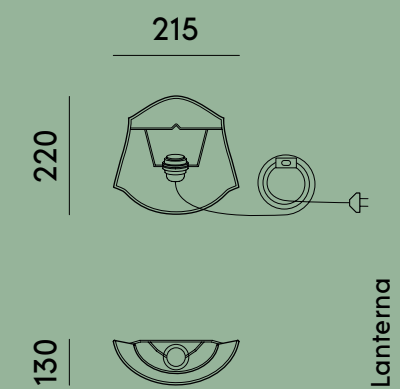

Lampshade
Fornasetti Foglie e Civette wallpaper

Lighting specifications
Light source: 1 x E27 Bulb Holder | E26 Bulb Holder
Power: Max LED 13W
Cable: Bordeaux silk alike fabric braided cable, 2 metres long
Plug: Euro Plug - Type C - 2 pins | USA Plug - Type A - 2 pins
Switch: On the cable
Wiring: CE | UL
Not dimmable

All dimensions expressed in mm

Cime Tempestose

"Cime Tempestose" è molto più di una semplice collezione di lampade: è un viaggio nella creatività senza confini di Servomuto. Ogni singola lampada, con le sue forme caratteristiche e le rifiniture contrastanti, è un capolavoro di design, pensato per impreziosire gli ambienti. La carta da parati "Nuvolette" di Fornasetti, dalle suggestive immagini in bianco e nero, aggiunge un tocco di romanticismo e mistero, trasportando chiunque nelle atmosfere letterarie di Emily Brontë. Le lampade "Cime tempestose" hanno un carattere unico e irripetibile: ogni pezzo, infatti, è frutto del lavoro artigianale di maestri, che le realizzano senza che ce ne siano due uguali. Utilizzate singolarmente per creare un punto focale suggestivo o raggruppate per formare un'installazione scenica, queste lampade trasformano un luogo in un'opera d'arte vivente, ricca di profondità e significato. In un mondo sempre più omologato, le lampade "Cime tempestose" si ergono come un faro di originalità e raffinatezza, pronte a lasciare la loro impronta in qualsiasi contesto.

"Cime Tempestose" is a stunning collection embodying Servomuto's elegance and creativity philosophy. The collection features lamps with two unique sconce shapes adorned with contrasting trims to complement the intricate design of Fornasetti's wallpaper, "Nuvolette". The wallpaper showcases a mesmerizing black-and-white depiction of an exotic landscape, reminiscent of Emily Brontë's romantic drama, "Wuthering Heights". Each lamp is a one-of-a-kind piece handmade by skilled artisans, ensuring that no two are exactly alike. Similarly, each cut of the wallpaper is unique, creating a bespoke experience for every customer. The lamps can be used as elegant standalone pieces or grouped together to create a stunning focal point that will elevate any space. The contrast between the sconce shapes and the wallpaper creates a sense of depth and dimension, while the contrasting trims provide an undeniable sense of luxury. All components of the lamps are designed to enhance the lighting experience, providing a sophisticated and glamorous style that will leave a lasting impression.



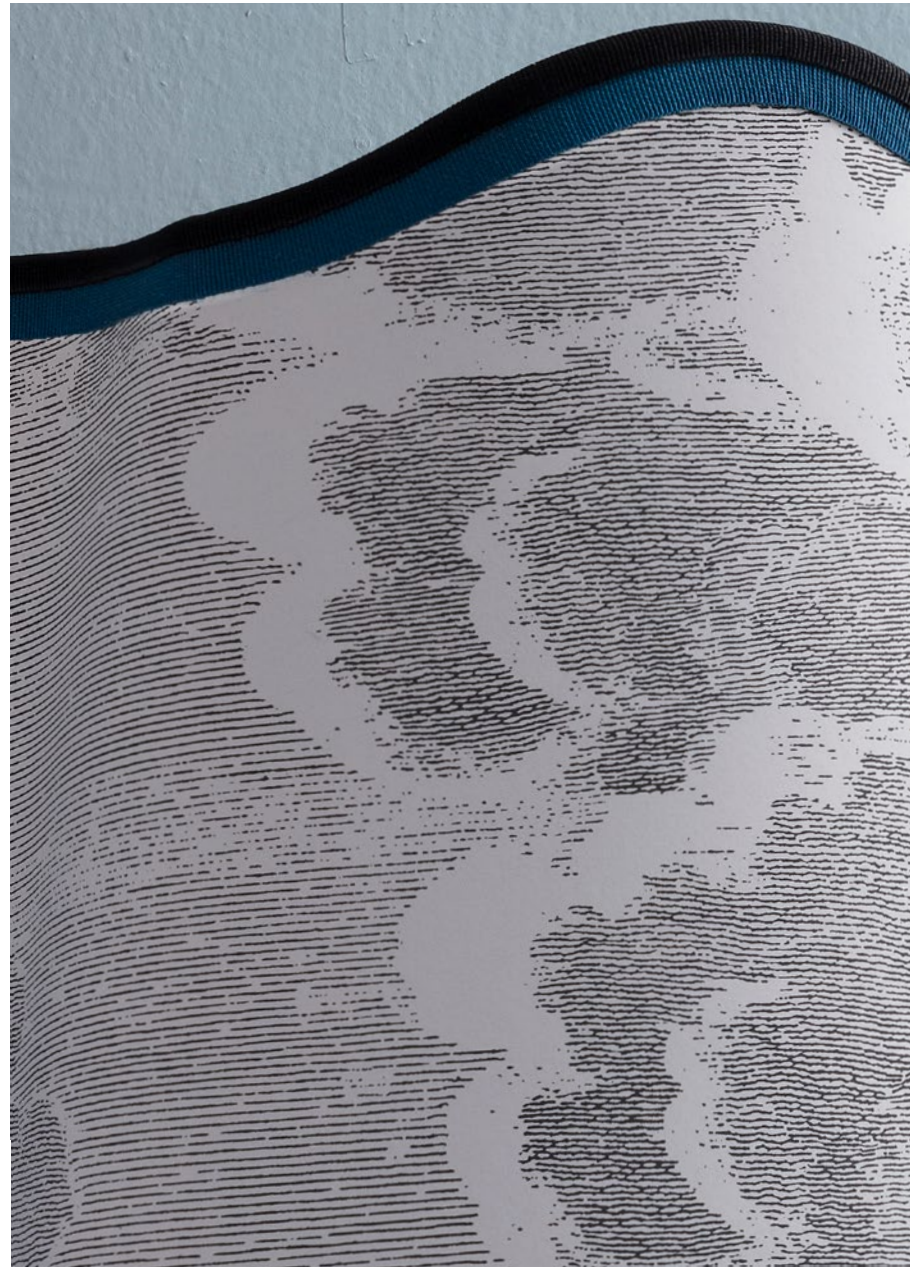



Cime Tempestose - Butterfly



Cime Tempestose - Gatto

Cime Tempestose

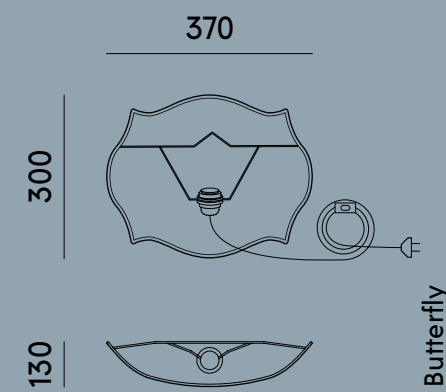

Butterfly

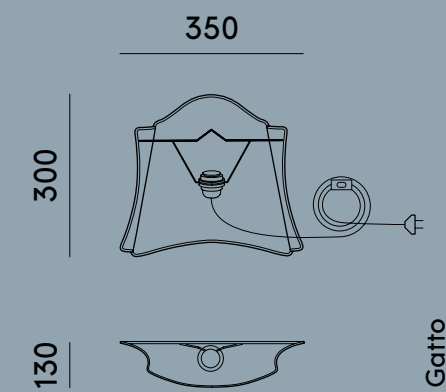

Gatto

Paralume
Carta da parati Nuvolette di Fornasetti

Specifiche di illuminazione
Fonte luminosa: 1 x E27 Portalampada | E26 Portalampada
Potenza: Max LED 13W
Cavo: A treccia rivestito in tessuto bordeaux effetto seta, lungo 2 metri
Spina: Presa Euro - Tipo C - 2 poli | Presa USA - Tipo A - 2 poli
Interruttore: sul cavo
Cablaggio: CE | UL
Non dimmerabile

Tutte le dimensioni sono espresse in mm

Lampshade
Fornasetti Nuvolette wallpaper

Lighting specifications
Light source: 1 x E27 Bulb Holder | E26 Bulb Holder
Power: Max LED 13W
Cable: Bordeaux silk alike fabric braided cable, 2 metres long
Plug: Euro Plug - Type C - 2 pins | USA Plug - Type A - 2 pins
Switch: On the cable
Wiring: CE | UL
Not dimmable

All dimensions expressed in mm

I Wanna Be Your Dog

Con "I Wanna Be Your Dog", Servomuto offre una rilettura provocatoria di un progetto del 2013, omaggiando l'energia travolgente del punk rock. Ispirata ai testi memorabili della canzone "1969" degli Stooges, questa collezione cattura l'anima ribelle e audace del movimento punk attraverso versi significativi che risuonano con forza. Le lampade "I Wanna Be Your Dog" si distinguono per le loro forme classiche in lino bianco, impreziosite da passamanerie anch'esse bianche, che accentuano l'intensità punk dei testi in un lettering nero. Il contrasto netto tra il tessuto candido e i testi ricamati è uno spettacolo visivo che caratterizza ogni ambiente con una personalità decisa. Oltre al concetto innovativo del design, ogni lampada della collezione "I Wanna Be Your Dog" è realizzata con estrema cura, dai dettagli del portalampada al tessuto del cavo. Queste lampade possono essere utilizzate singolarmente per aggiungere un tocco di originalità agli spazi, oppure raggruppate per creare un'atmosfera vibrante, in perfetto stile punk. In ogni caso, irradiano passione e ribellione, e gli appassionati più incalliti del genere troveranno nel loro design un'espressione tangibile del loro spirito sovversivo. Con la sua estetica e il suo carattere, la collezione "I Wanna Be Your Dog" celebra la cultura del punk rock e il suo impatto duraturo sulla società e sulla creatività.

"I Wanna Be Your Dog" is a re-edition of a 2013 Servomuto project that pays homage to the raw energy of punk rock with its bold design and rebellious spirit. Inspired by the iconic lyrics of The Stooges' "1969" song, this collection features potent lyric extracts that capture the defiant spirit of the punk movement. The brand's trademark thoughtfulness sees the "I Wanna Be Your Dog" lamps in classic shapes in white linen, accented with white trimmings to emphasize the punk intensity of the text. The stark contrast between the white fabric and the bold black embroidered lettering creates an arresting visual impact, making these lamps a statement for any space. In addition to their bold design, each lamp in the "I Wanna Be Your Dog" collection comes with a lamp holder and fabric cable. The lamps can be used as standalone pieces for a touch of edge to a room or grouped to create a cohesive punk-inspired aesthetic. In any case, they will ignite passion and rebellion, and the die-hard punk enthusiasts will look to manifest their attitude to the home décor: the "I Wanna Be Your Dog" collection illustrates the path to achieve that. With its bold design elements and rebellious spirit, it celebrates punk rock culture and the enduring power of music to inspire and provoke.



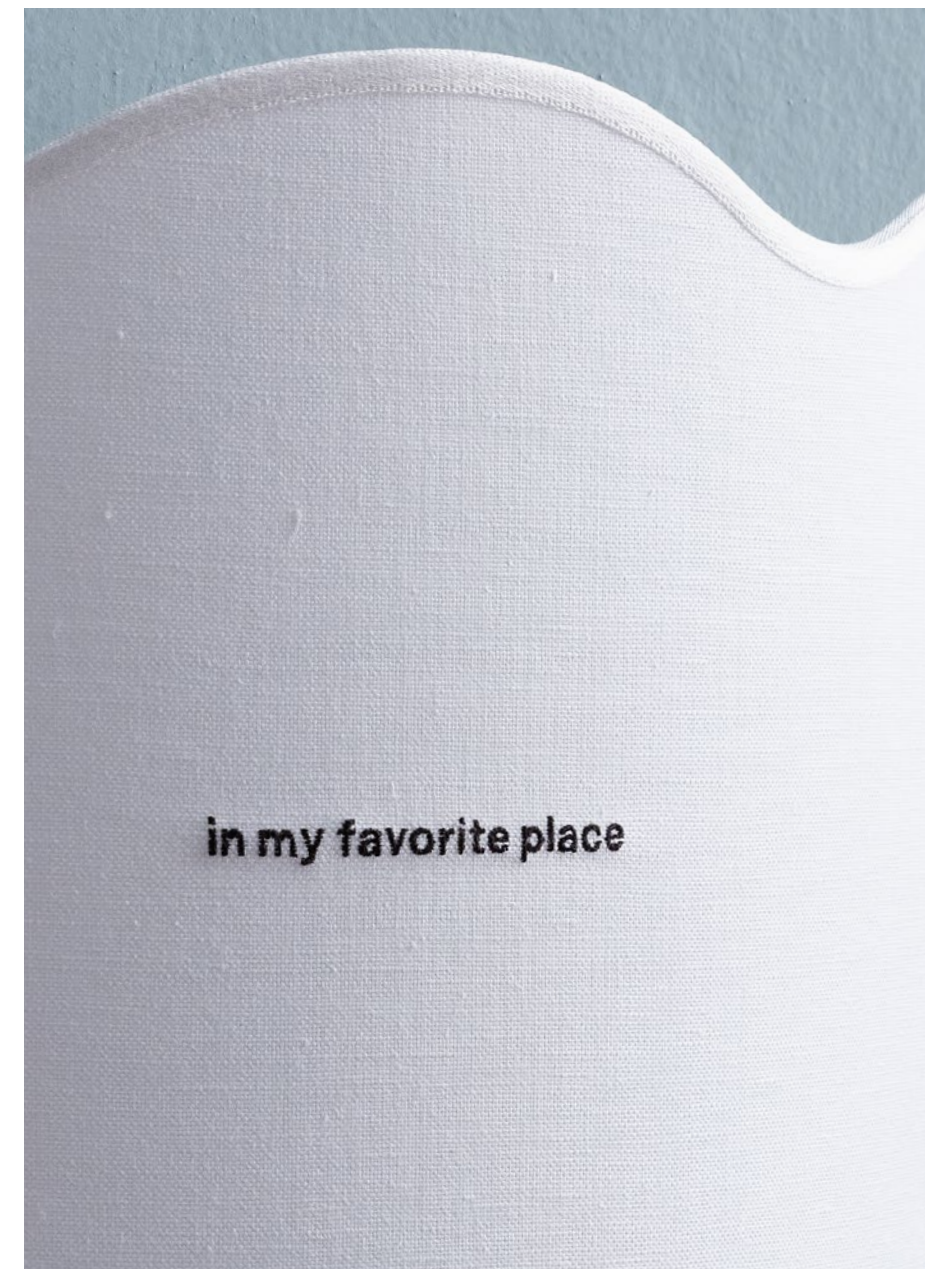
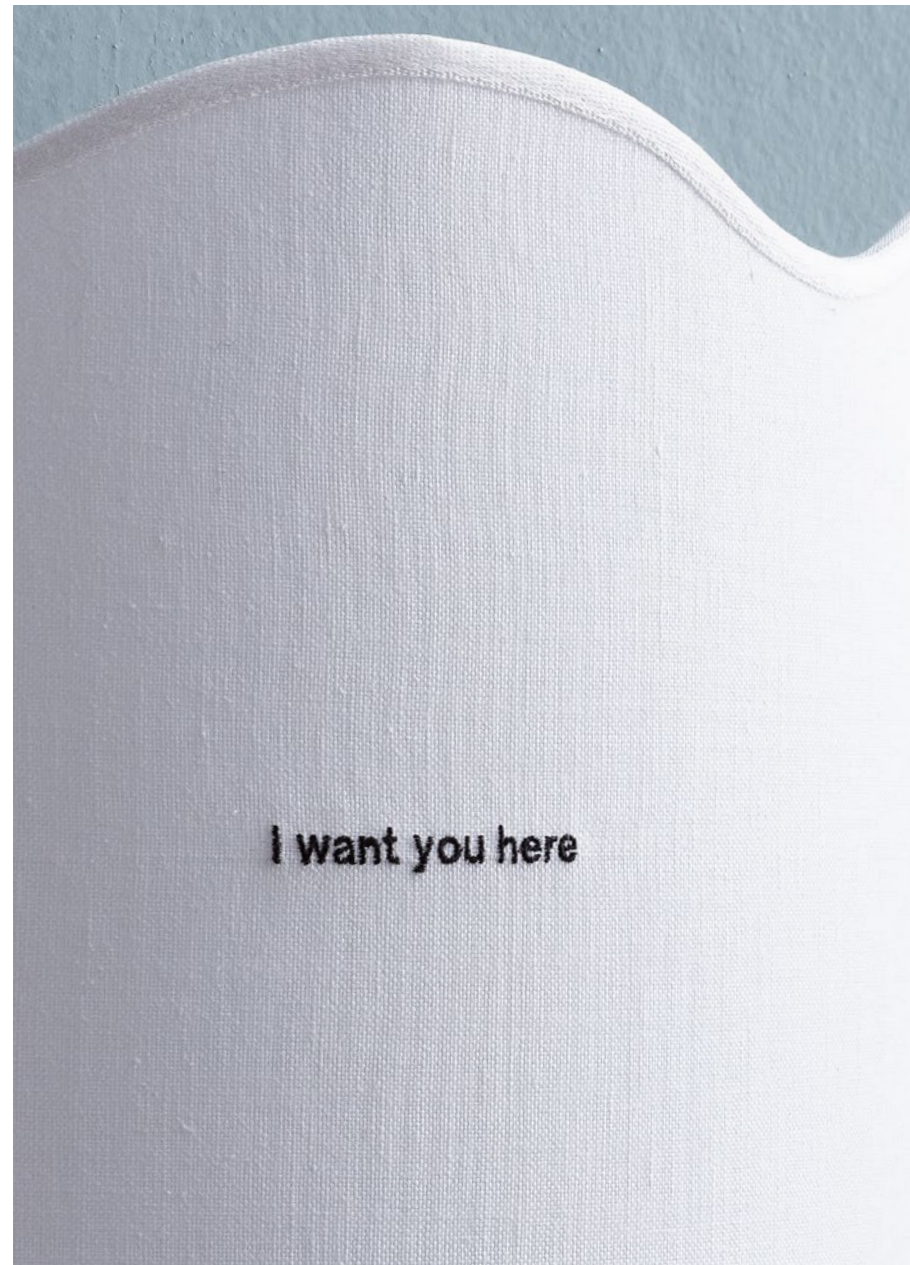



I Wanna Be Your Dog - Butterfly #1
In my favourite place



I Wanna Be Your Dog - Butterfly #2
I want you here



I Wanna Be Your Dog - Quadro
Lose my heart on the burning sands



I Wanna Be Your Dog - Scudo
I wanna be your dog

I Wanna Be Your Dog

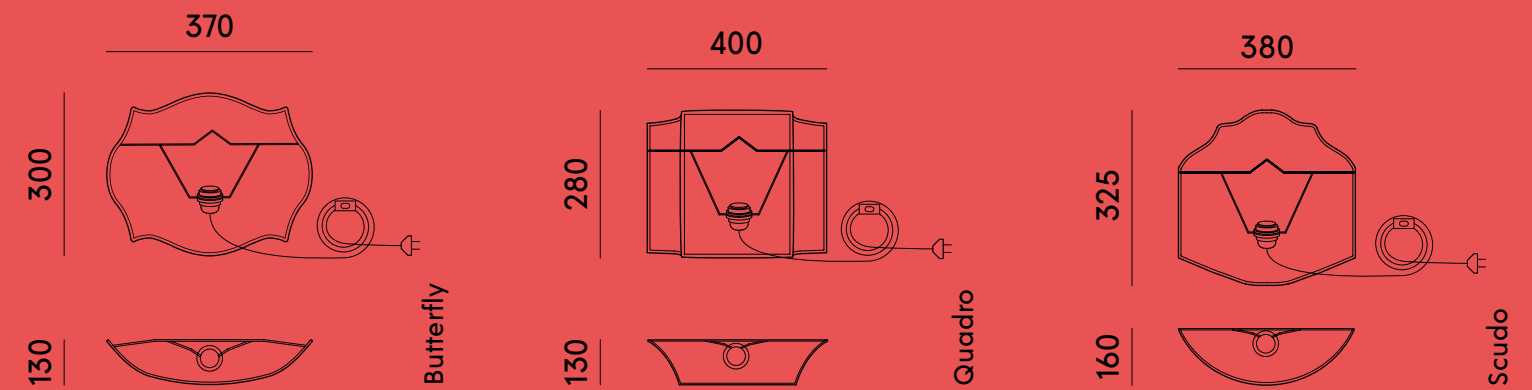

Paralume
Tessuto in lino bianco con ricamo nero

Specifiche di illuminazione
Fonte luminosa: 1 x E27 Portalampada | E26 Portalampada
Potenza: Max LED 13W
Cavo: A treccia rivestito in tessuto bordeaux effetto seta, lungo 2 metri
Spina: Presa Euro - Tipo C - 2 poli | Presa USA - Tipo A - 2 poli
Interruttore: sul cavo
Cablaggio: CE | UL
Non dimmerabile

Tutte le dimensioni sono espresse in mm

Lampshade
Black embroidery on white linen fabric

Lighting specifications
Light source: 1 x E27 Bulb Holder | E26 Bulb Holder
Power: Max LED 13W
Cable: Bordeaux silk alike fabric braided cable, 2 metres long
Plug: Euro Plug - Type C - 2 pins | USA Plug - Type A - 2 pins
Switch: On the cable
Wiring: CE | UL
Not dimmable

All dimensions expressed in mm

Satisfaction

Le lampade "Satisfaction" incarnano l'amore incondizionato e la passione irrefrenabile. Questa collezione evoca un senso di piacere e soddisfazione, combinando forme eleganti e contemporanee con la carta da parati esclusiva di Pierre Frey, "Le Couple". Illustrata dalla talentuosa attrice francese Louise Bourgoïn, la carta da parati "Le Couple" presenta disegni intricati a inchiostro che omaggiano i momenti più intimi, irriverenti e naturali della vita di coppia, con elementi grafici provocatori. Ogni applique è ornata con una porzione diversa della carta da parati, creando un'estetica dinamica e coinvolgente. Sebbene alcune scene possano essere più esplicite, raffigurando immagini dall'allusione sessuale, queste servono a rafforzare ulteriormente il tema del desiderio della collezione. Sia utilizzate singolarmente, per suscitare curiosità, sia raggruppate, per creare un quadro d'insieme seducente, le lampade "Satisfaction" spingono gli osservatori a esplorare le molteplici sfaccettature della natura umana, e trasformano ogni ambiente in un regno di sensualità, garantendo uno stile unico e distintivo. Questa collezione celebra l'amore, la passione, il desiderio e un'estetica senza compromessi.

The "Satisfaction" lamps represent unapologetic love and unbridled passion. This collection evokes satisfaction and fulfillment, combining sleek, contemporary shapes with the exclusive Pierre Frey wallpaper, "Le Couple". Illustrated by the talented French actress Louise Bourgoïn, the wallpaper stars intricate ink drawings that pay homage to the most private, flippant, and natural moments of a couple's life with bold and provocative design elements. Each sconce is adorned with a different portion of the "Le Couple" wallpaper, creating a dynamic and visually captivating aesthetic. While some scenes may be more explicit, depicting sexually suggestive imagery, they serve to further enhance the collection's theme of unrepentant desire. Whether standalone to intrigue the atmosphere or group to create a catchy wall display, the "Satisfaction" lamps will leave a mark, inviting the viewers to explore the complexities of human nature. They turn every space into a frenzy of sensuality, creating a bold statement that offers a unique style. This collection celebrates love, passion, straightforward desire, and imagery.







Satisfaction - Butterfly



Satisfaction - Cameo



Satisfaction - Gatto

Satisfaction

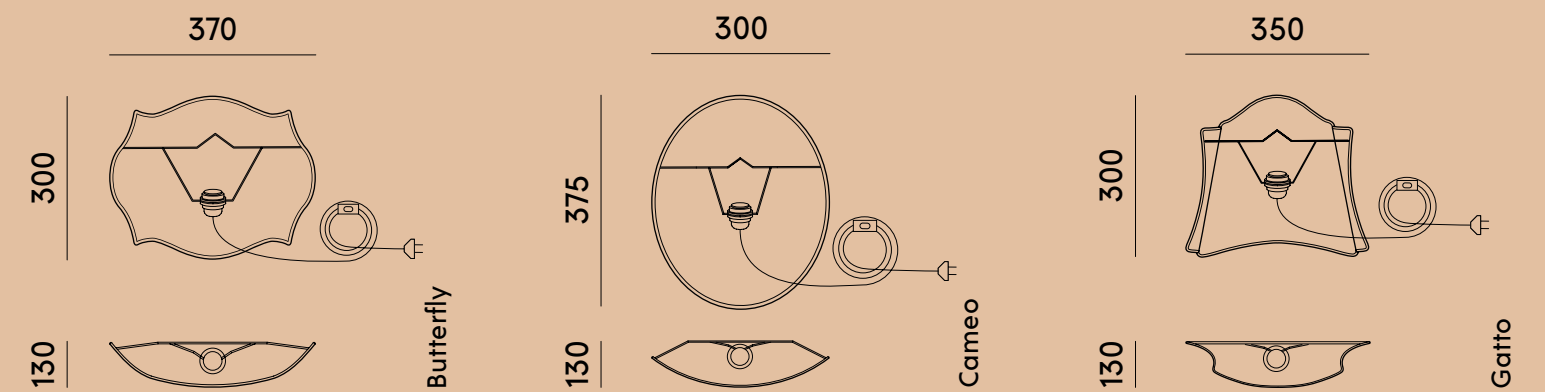

Paralume
Carta da parati Le Couple di Pierre Frey

Specifiche di illuminazione
Fonte luminosa: 1 x E27 Portalampada | E26 Portalampada
Potenza: Max LED 13W
Cavo: A treccia rivestito in tessuto bordeaux effetto seta, lungo 2 metri
Spina: Presa Euro - Tipo C - 2 poli | Presa USA - Tipo A - 2 poli
Interruttore: sul cavo
Cablaggio: CE | UL
Non dimmerabile

Tutte le dimensioni sono espresse in mm

Lampshade
Pierre Frey Le Couple wallpaper

Lighting specifications
Light source: 1 x E27 Bulb Holder | E26 Bulb Holder
Power: Max LED 13W
Cable: Bordeaux silk alike fabric braided cable, 2 metres long
Plug: Euro Plug - Type C - 2 pins | USA Plug - Type A - 2 pins
Switch: On the cable
Wiring: CE | UL
Not dimmable

All dimensions expressed in mm

Custom products available upon request.
Prodotti custom disponibili su richiesta.
sales@servomuto.it

Servomuto, via Olona 25, 20123 Milano
servomuto.it



Servomuto
via Olona 25
20123 Milano